



MMIC SURFACE MOUNT

Low Noise Amplifier PMA4-6263LN+

50Ω 6 to 26.5 GHz Wideband Amplifier

THE BIG DEAL

- High Gain, Typ. 24.6 dB
- High OIP3, Typ. +22.8 dBm
- Low Noise Figure, Typ. 2.5 dB
- Self-Biased with Low Power Consumption, +4 V @ 52.5 mA
- 4x4 mm 24-Lead QFN-Style Package

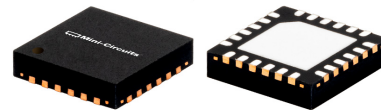

Generic photo used for illustration purposes only

APPLICATIONS

- Back Haul Radio Systems
- Satellite Communications
- Test & Measurement Equipment
- Radar, EW, and ECM Defense Systems

FUNCTIONAL DIAGRAM

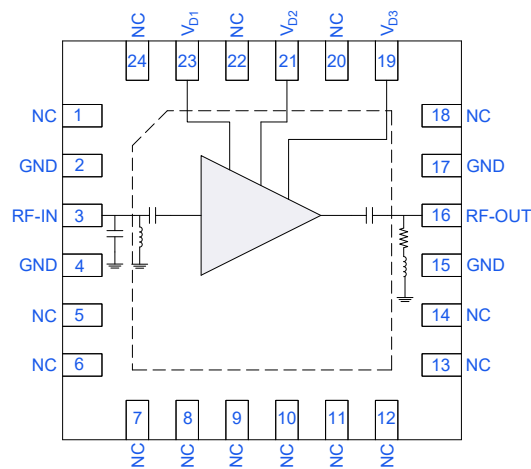

PRODUCT OVERVIEW

Mini-Circuits' PMA4-6263LN+ is a pHEMT-based low-noise MMIC amplifier with high gain and low power consumption. Operating from 6 to 26.5 GHz, this amplifier features typical 2.5 dB noise figure, 24.6 dB gain, +9.9 dBm P1dB, and +22.8 dBm OIP3. This device is self-biased, requiring only a single +4 V supply voltage, and is well-matched to 50Ω coming in a small 4x4 mm 24-Lead QFN style package for easy integration into dense circuit board layouts.

KEY FEATURES

Features	Advantages
Low Noise Figure, Typ. 2.5 dB at High Frequency	This low noise MMIC device enables low system noise figure performance without the need for complicated discrete-based solutions.
Low Power Consumption, Typ. +4 V @ 52.5 mA	At only 52.5 mA, this amplifier is ideal for applications with limited available power or densely packed applications where thermal and power management is critical. Additionally, this model only requires a +4 V supply voltage, eliminating the need for complicated sequencing schemes to accommodate multiple voltages.
4x4 mm 24-Lead QFN-Style Package	Small footprint saves space in dense layouts while providing low inductance, repeatable transitions, and excellent thermal contact to the PCB. Industry standard packaging allows for ease of assembly in high volume manufacturing processes.





MMIC SURFACE MOUNT

Low Noise Amplifier **PMA4-6263LN+**

Mini-Circuits

50Ω 6 to 26.5 GHz Wideband Amplifier

ELECTRICAL SPECIFICATIONS¹ AT +25°C, V_{DD} = +4 V, Z_o = 50Ω UNLESS NOTED OTHERWISE

Parameter	Condition (GHz)	Min.	Typ.	Max.	Units
Frequency Range		6		26.5	GHz
Gain	6	18.9	21.2		dB
	10	21.1	23.6		
	15	19.6	22.7		
	20	21.2	24.6		
	26.5	21.9	26.2		
Input Return Loss	6		10		dB
	10		12		
	15		11		
	20		11		
	26.5		19		
Output Return Loss	6		12		dB
	10		12		
	15		12		
	20		14		
	26.5		13		
Isolation	6 - 26.5		66.7		dB
Output Power at 1 dB Compression (P _{1dB})	6		+9.9		dBm
	10		+9.1		
	15		+10.3		
	20		+9.9		
	26.5		+6.7		
Output Power at Saturation (P _{SAT}) ²	6		+11.9		dBm
	10		+14.4		
	15		+14.1		
	20		+14.0		
	26.5		+12.9		
Output Third-Order Intercept (OIP3) (P _{OUT} = -5 dBm/Tone)	6		+18.9		dBm
	10		+21.7		
	15		+22.3		
	20		+22.8		
	26.5		+20.5		
Noise Figure	6		2.7		dB
	10		2.2		
	15		2.4		
	20		2.5		
	26.5		2.6		
Device Operating Voltage (V _{DD}) ³		+3.5	+4.0	+5.0	V
Device Operating Current (I _{D1}) ⁴			9.5		mA
Device Operating Current (I _{D2}) ⁴			12.6		mA
Device Operating Current (I _{D3}) ⁴			30.4		mA
Device Current Variation Vs. Temperature ⁵			-45.28		μA/°C
Device Current Variation Vs. Voltage ⁶			18.0		μA/mV

1. Tested in Mini-Circuits Characterization Test/Evaluation Board TB-PMA46263LNC+. See Figure 2. De-embedded to the device reference plane.

2. Defined as Output Power at which change is 0.1 dB per 1 dB change in input power.

3. V_{DD} = V_{D1} = V_{D2} = V_{D3}

4. Current at P_{IN} = -25 dBm. Total current (I_{D1} + I_{D2} + I_{D3}) increases to 65 mA at P_{1dB} when V_{DD} = +4 V.

5. ((Current at +105°C) - (Current at -45°C))/(+150°C)

6. ((Current at +5 V) - (Current at +3.5 V))/(+5 V - +3.5 V)





Low Noise Amplifier PMA4-6263LN+

TYPICAL PERFORMANCE GRAPHS

Note: All data taken at nominal condition $V_{DD} = +4$ V unless noted otherwise.

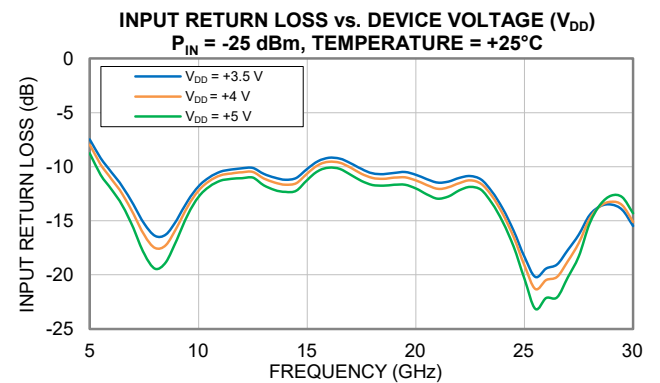
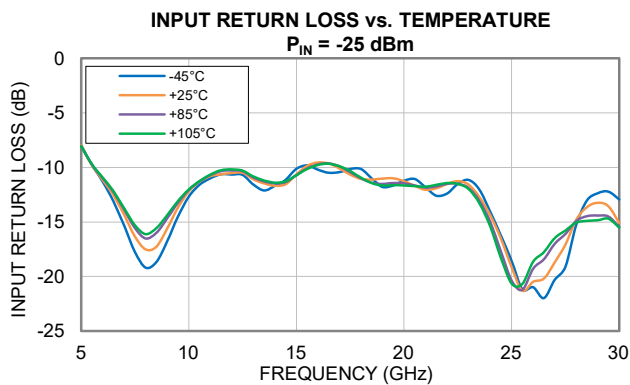
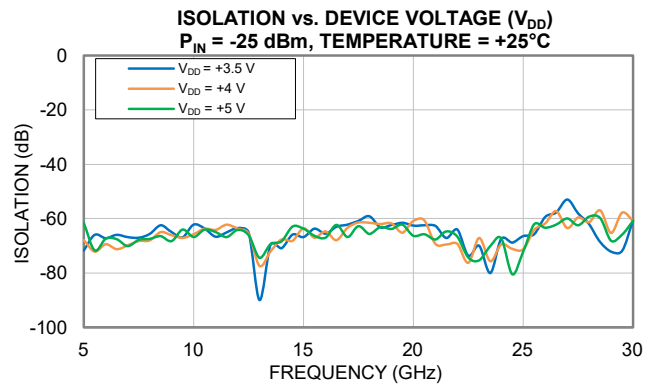
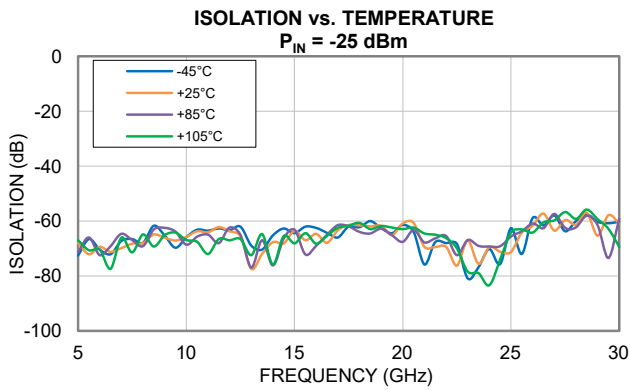
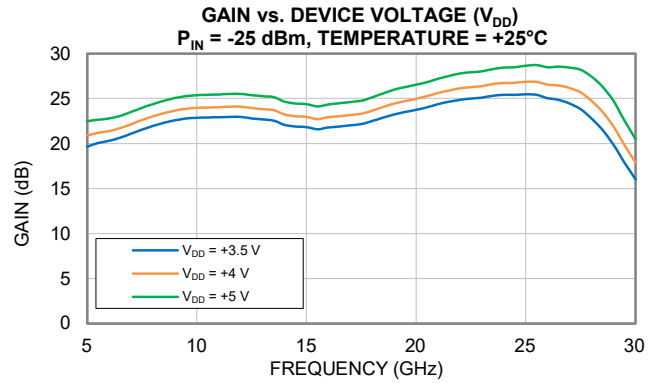
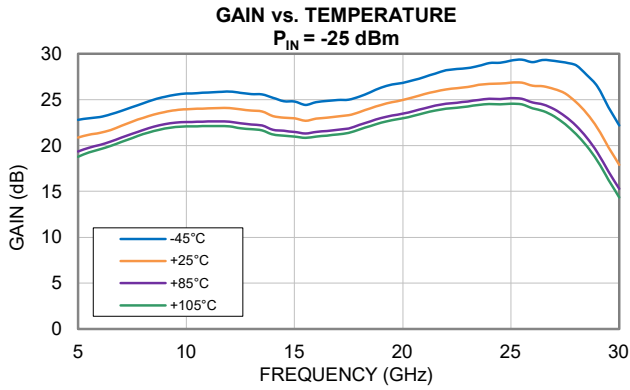



TYPICAL PERFORMANCE GRAPHS

Note: All data taken at nominal condition $V_{DD} = +4$ V unless noted otherwise.

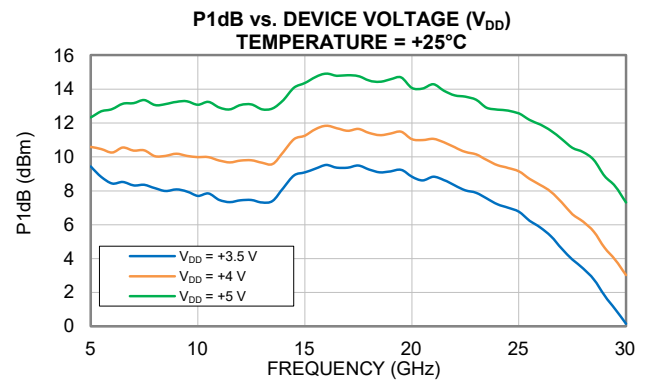
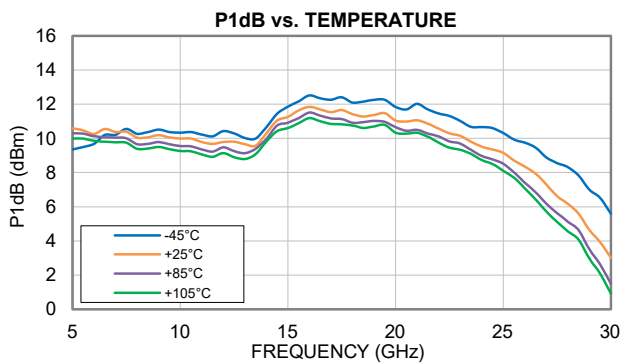
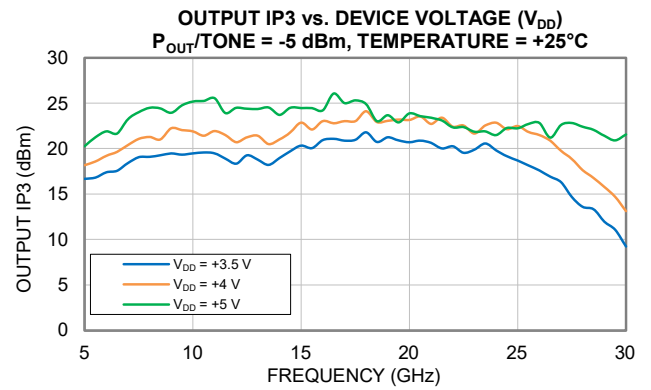
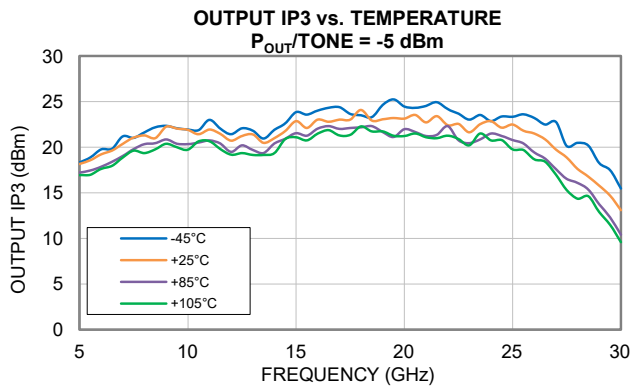
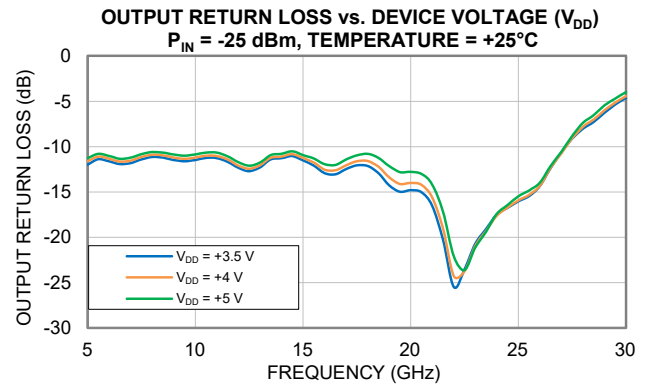
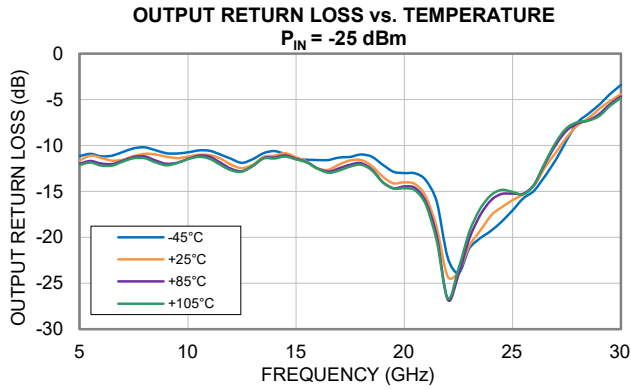



MMIC SURFACE MOUNT

Low Noise Amplifier PMA4-6263LN+

50Ω 6 to 26.5 GHz Wideband Amplifier

TYPICAL PERFORMANCE GRAPHS

Note: All data taken at nominal condition $V_{DD} = +4$ V unless noted otherwise.

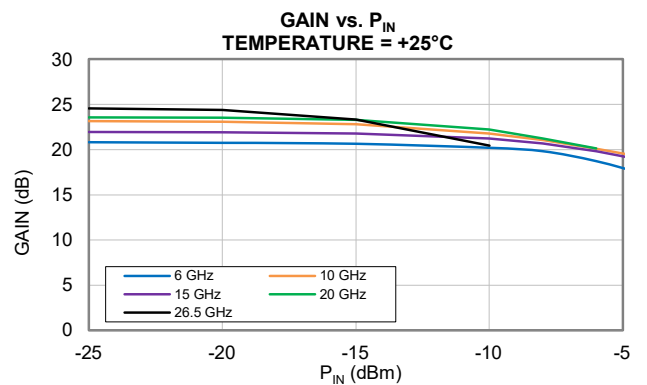
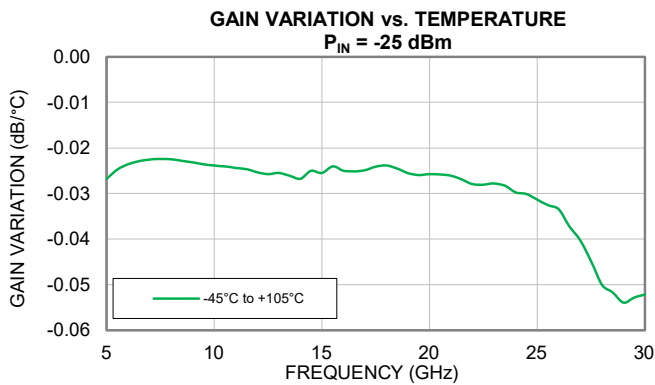
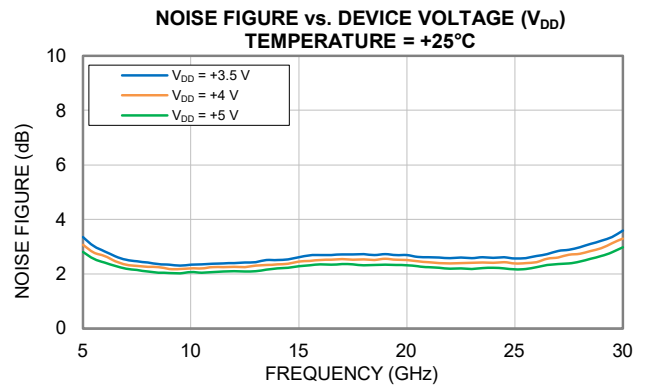
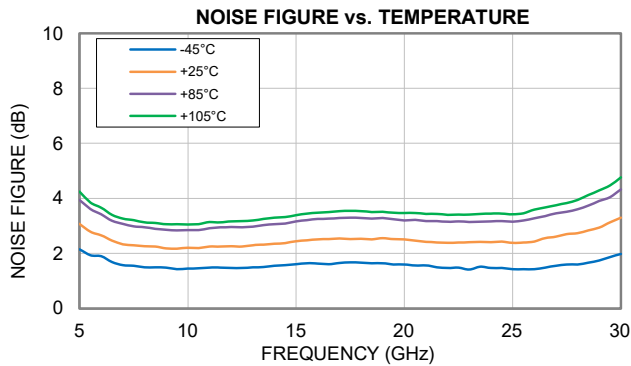
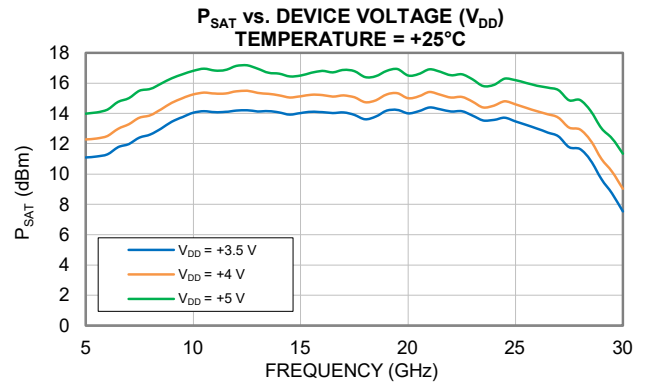
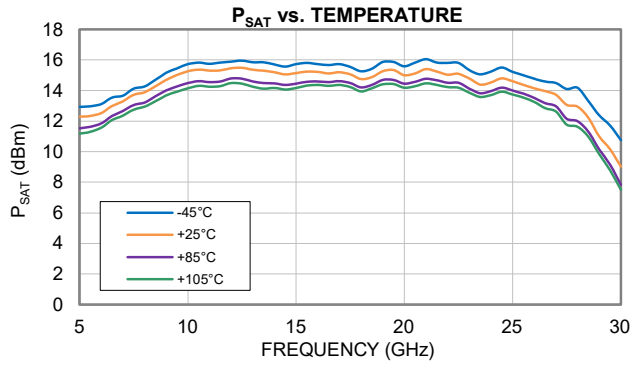



MMIC SURFACE MOUNT

Low Noise Amplifier **PMA4-6263LN+**

Mini-Circuits

50Ω 6 to 26.5 GHz Wideband Amplifier

TYPICAL PERFORMANCE GRAPHS

Note: All data taken at nominal condition $V_{DD} = +4$ V unless noted otherwise.

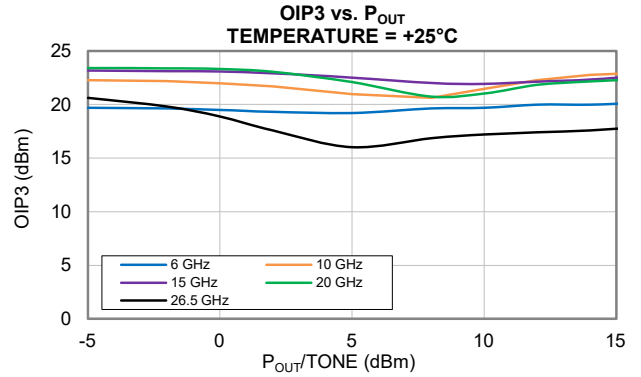
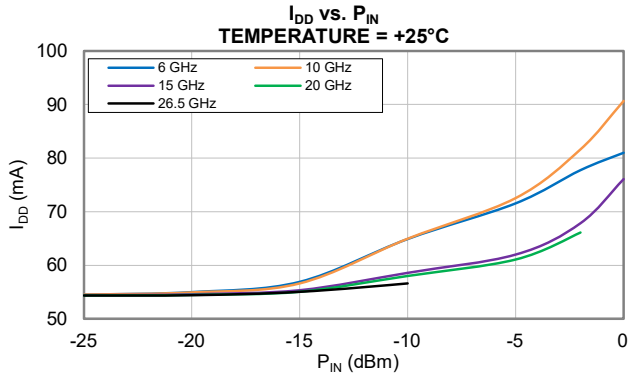



MMIC SURFACE MOUNT

Low Noise Amplifier **PMA4-6263LN+**

Mini-Circuits

50Ω 6 to 26.5 GHz Wideband Amplifier

ABSOLUTE MAXIMUM RATINGS⁷

Parameter	Ratings
Operating Temperature	-45°C to +105°C
Storage Temperature	-65°C to +150°C
Total Power Dissipation	0.86 W
Junction Temperature ⁸	+175°C
Input Power (CW), $V_{DD}^9 = +4$ V	+19 dBm
DC Voltage on RF-OUT	+11 V
DC Voltage on RF-IN	+2.6 V
DC Drain Voltage on V_{DD}^9	+9 V
DC Drain Current I_{D1}	100 mA
DC Drain Current I_{D2}	100 mA
DC Drain Current I_{D3}	90 mA

7. Permanent damage may occur if any of these limits are exceeded. Maximum ratings are not intended for continuous operation.

8. Peak temperature on top of Die.

9. $V_{DD} = V_{D1} = V_{D2} = V_{D3}$

THERMAL RESISTANCE

Parameter	Ratings
Thermal Resistance (Θ_{JC}) ¹⁰	52.2°C/W

10. $\Theta_{JC} = (\text{Hot Spot Temperature on Die} - \text{Temperature at Ground Lead}) / \text{Dissipated Power}$

ESD RATING

	Class	Voltage Range	Reference Standard
HBM	1B	500 to < 1000 V	ANSI/ESDA/JEDEC JS-001-2023
CDM	C2A	500 to < 750 V	ANSI/ESDA/JEDEC JS-002-2022



ESD HANDLING PRECAUTION: This device is designed to be Class 1B for HBM. Static charges may easily produce potentials higher than this with improper handling and can discharge into DUT and damage it. As a preventive measure Industry standard ESD handling precautions should be used at all times to protect the device from ESD damage.

MSL RATING

Moisture Sensitivity: MSL1 in accordance with IPC/JEDEC J-STD-020E/JEDEC J-STD-033C



MMIC SURFACE MOUNT

Low Noise Amplifier PMA4-6263LN+

50Ω 6 to 26.5 GHz Wideband Amplifier

FUNCTIONAL DIAGRAM

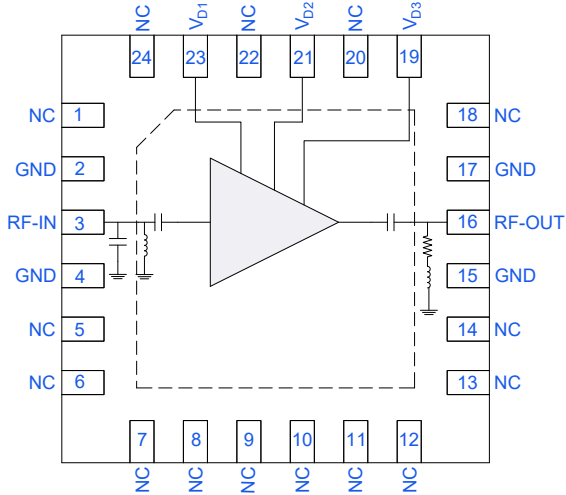

Figure 1. PMA4-6263LN+ Functional Diagram

PAD DESCRIPTION

Function	Pad Number	Description (Refer to Figure 2)
RF-IN	3	RF-IN pad connects to RF-Input port.
RF-OUT	16	RF-OUT pad connects to RF-Output port.
V _{D1}	23	DC Input pad connects to voltage input port, V _{D1} .
V _{D2}	21	DC Input pad connects to voltage input port, V _{D2} .
V _{D3}	19	DC Input pad connects to voltage input port, V _{D3} .
GND	2, 4, 15, 17, & Paddle	Connects to ground.
NC	1, 5-14, 18, 20, 22, & 24	Not used internally. Connected to ground on test board.

EVALUATION BOARD

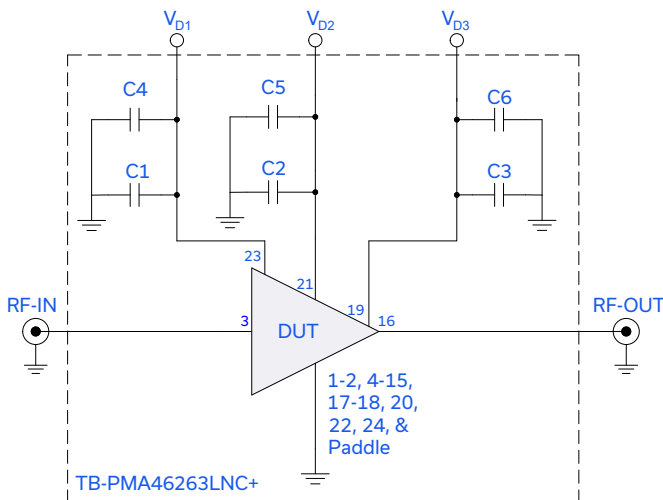

Figure 2. PMA4-6263LN+ Evaluation and Application Circuit

Electrical Parameters and Conditions

Gain, Return Loss, Output Power at 1dB Compression (P_{1dB}), Output IP3 (OIP3), Saturated Output Power (P_{SAT}), and Noise Figure measured using N5247B PNA-X Microwave Network Analyzer.

Conditions:

- Gain and Return Loss: P_{IN} = -25 dBm
- Output IP3 (OIP3): Two tones, spaced 1 MHz apart, -5 dBm/Tone at output.

Power ON/Power OFF Sequence:

PMA4-6263LN+ is not sensitive to power ON/OFF sequence. V_{D1}, V_{D2}, and V_{D3} can be applied in any order. All three voltage lines may be tied together and applied simultaneously.

Component	Value	Size	Part Number	Manufacturer
C1, C2, C3	100 pF	0402	GRM1555C1H101JA01D	MURATA
C4, C5, C6	0.1 μF	0603	GCM188R71E104JA57D	MURATA





MMIC SURFACE MOUNT

Low Noise Amplifier PMA4-6263LN+

Mini-Circuits

50Ω 6 to 26.5 GHz Wideband Amplifier

CASE STYLE DRAWING

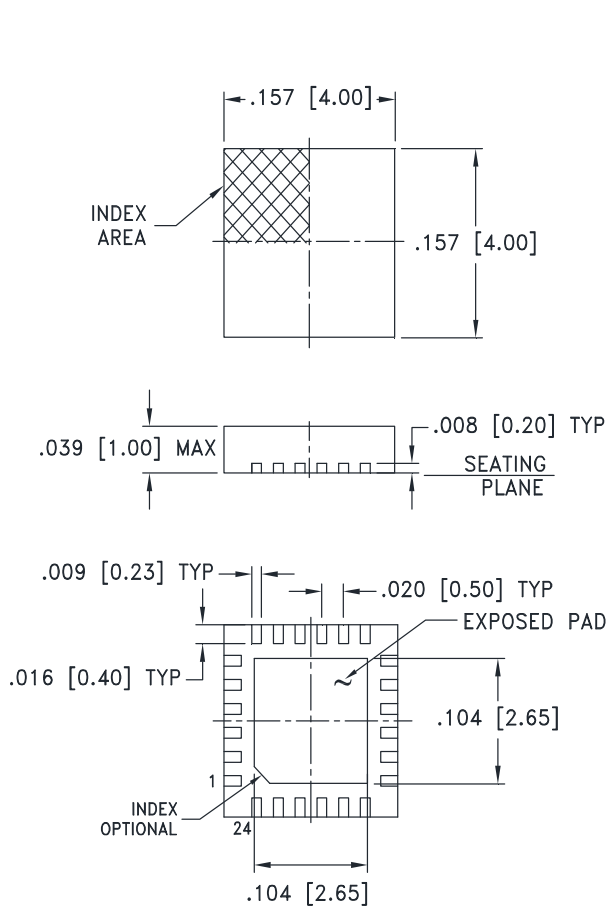

PCB Land Pattern

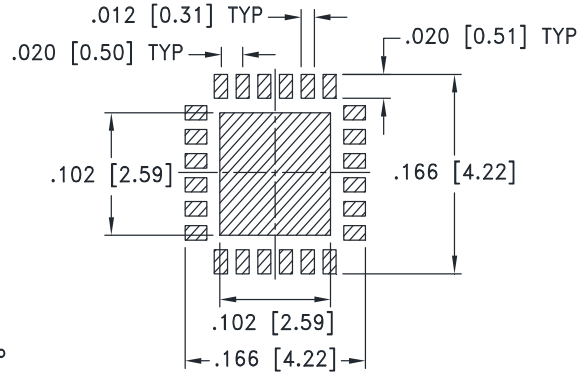

SUGGESTED LAYOUT,
TOLERANCE TO BE WITHIN $\pm .002$

Weight: .04 Grams

Dimensions are in inches [mm]. Tolerances in inches: 2 Pl. $\pm .01$; 3 Pl. $\pm .005$ inches

PRODUCT MARKING

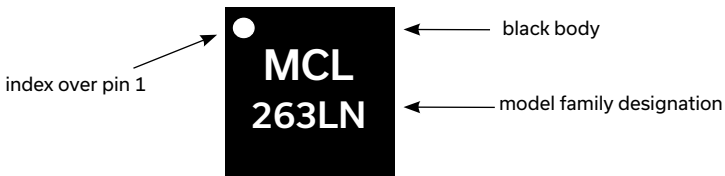

Marking may contain other features or characters for internal lot control





MMIC SURFACE MOUNT

Low Noise Amplifier **PMA4-6263LN+**

50Ω 6 to 26.5 GHz Wideband Amplifier

ADDITIONAL DETAILED INFORMATION IS AVAILABLE ON OUR DASHBOARD [CLICK HERE](#)

Performance Data & Graphs	Data Graphs S-Parameter (S2P Files) Data Set (.zip file)
Case Style	DG1847. Plastic package, exposed paddle, Lead Finish: Matte-Tin
RoHS Status	Compliant
Tape & Reel Standard quantities available on reel	F68 7" reels with 20, 50, 100, 200, 500, or 1000 devices
Suggested Layout for PCB Design	PL-799
Evaluation Board	TB-PMA46263LNC+ Gerber File
Environmental Ratings	ENV08T1

NOTES

- A. Performance and quality attributes and conditions not expressly stated in this specification document are intended to be excluded and do not form a part of this specification document.
- B. Electrical specifications and performance data contained in this specification document are based on Mini-Circuit's applicable established test performance criteria and measurement instructions.
- C. The parts covered by this specification document are subject to Mini-Circuits standard limited warranty and terms and conditions (collectively, "Standard Terms"); Purchasers of this part are entitled to the rights and benefits contained therein. For a full statement of the standard terms and the exclusive rights and remedies thereunder, please visit Mini-Circuits' website at www.minicircuits.com/terms/viewterm.html



Typical Performance Data

NOTE: Use PDF Bookmarks to view DATA at required conditions

Definitions:

Input Return Loss = -S11 (dB)

Gain(Power Gain) = S21 (dB)

Reverse Isolation = -S12 (dB)

Output Return Loss = -S22 (dB)

TEST CONDITIONS: $V_{D1} = +3.5\text{ V}$, $V_{D2} = +3.5\text{ V}$, $V_{D3} = +3.5\text{ V}$, $I_{D1} = 8.6\text{ mA}$, $I_{D2} = 10.3\text{ mA}$, $I_{D3} = 25.3\text{ mA}$ @ Temperature = +25°C

FREQ	Gain	Isolation	Input Return Loss	Output Return Loss	Stability		IP-3 Output	1dB Comp. Output	P _{SAT} Output	Noise Figure
					K	Measure				
(GHz)	(dB)	(dB)	(dB)	(dB)	K	Measure	(dBm)	(dBm)	(dBm)	(dB)
5.00	19.6	-71.6	-7.5	-12.0	164.5	1.1	16.7	9.4	11.1	3.3
5.50	20.1	-65.9	-9.2	-11.4	86.7	1.0	16.8	8.8	11.2	3.0
6.00	20.3	-67.2	-10.5	-11.6	102.3	1.0	17.4	8.4	11.3	2.8
6.50	20.6	-65.9	-11.8	-11.9	88.1	1.0	17.6	8.5	11.8	2.6
7.00	21.1	-66.8	-13.5	-11.8	94.9	1.0	18.4	8.3	12.0	2.5
7.50	21.5	-67.0	-15.3	-11.4	93.6	1.0	19.1	8.4	12.4	2.5
8.00	21.9	-65.7	-16.4	-11.1	76.7	0.9	19.1	8.2	12.6	2.4
8.50	22.3	-62.4	-16.3	-11.2	51.0	0.9	19.3	8.0	13.0	2.4
9.00	22.6	-65.0	-14.9	-11.5	66.1	1.0	19.5	8.1	13.5	2.3
9.50	22.8	-66.9	-13.2	-11.6	80.0	1.0	19.4	8.0	13.8	2.3
10.00	22.9	-62.1	-11.8	-11.5	45.1	1.0	19.5	7.7	14.0	2.3
10.50	22.9	-63.6	-11.0	-11.2	52.3	1.0	19.6	7.8	14.1	2.4
11.00	22.9	-66.6	-10.5	-11.3	73.2	1.0	19.5	7.5	14.1	2.4
11.50	23.0	-65.1	-10.3	-11.7	61.0	1.0	18.9	7.3	14.1	2.4
12.00	23.0	-63.5	-10.2	-12.3	51.7	1.0	18.3	7.4	14.2	2.4
12.50	22.8	-65.0	-10.1	-12.7	63.0	1.0	19.3	7.5	14.2	2.4
13.00	22.7	-90.0	-10.7	-12.3	1143.6	1.0	18.8	7.3	14.1	2.4
13.50	22.6	-69.5	-11.0	-11.4	109.1	1.0	18.2	7.4	14.1	2.5
14.00	22.1	-70.9	-11.2	-11.3	136.3	1.0	19.0	8.2	14.1	2.5
14.50	21.9	-65.8	-11.0	-11.1	77.2	1.0	19.7	8.9	13.9	2.5
15.00	21.8	-66.7	-10.2	-11.5	85.8	1.0	20.3	9.1	14.0	2.6
15.50	21.6	-63.7	-9.5	-12.1	61.6	1.0	20.1	9.3	14.1	2.7
16.00	21.8	-65.5	-9.2	-12.9	74.6	1.1	21.0	9.5	14.1	2.7
16.50	21.9	-63.0	-9.2	-13.1	55.6	1.1	21.1	9.4	14.0	2.7
17.00	22.0	-62.2	-9.7	-12.5	50.2	1.0	20.9	9.4	14.1	2.7
17.50	22.2	-60.8	-10.2	-12.1	42.8	1.0	21.0	9.5	13.9	2.7
18.00	22.5	-59.1	-10.6	-12.1	34.1	1.0	21.8	9.3	13.6	2.7
18.50	22.9	-63.2	-10.7	-12.9	53.3	1.0	20.7	9.1	13.8	2.7
19.00	23.2	-62.3	-10.6	-14.3	47.2	1.0	21.2	9.1	14.2	2.7
19.50	23.5	-61.5	-10.5	-15.0	42.0	1.1	20.9	9.2	14.2	2.7
20.00	23.7	-62.6	-10.8	-14.8	46.4	1.0	20.7	8.8	14.0	2.7
20.50	24.0	-62.4	-11.1	-15.0	44.7	1.0	20.9	8.6	14.1	2.6
21.00	24.4	-62.7	-11.5	-16.5	45.2	1.0	20.6	8.8	14.4	2.6
21.50	24.6	-67.1	-11.4	-20.2	73.6	1.1	20.0	8.6	14.3	2.6
22.00	24.8	-64.1	-11.0	-25.5	51.1	1.1	20.3	8.3	14.1	2.6
22.50	25.0	-73.6	-10.9	-23.6	151.2	1.1	19.6	8.0	14.2	2.6
23.00	25.1	-70.0	-11.2	-20.7	99.0	1.1	19.9	7.9	13.9	2.6
23.50	25.3	-80.0	-12.3	-19.1	311.0	1.0	20.6	7.5	13.5	2.6
24.00	25.4	-67.4	-13.9	-17.5	73.4	1.0	19.8	7.2	13.6	2.6
24.50	25.4	-68.8	-15.9	-16.8	87.4	1.0	19.2	7.0	13.7	2.6
25.00	25.5	-66.4	-18.3	-16.0	66.5	1.0	18.7	6.8	13.5	2.6
25.50	25.4	-65.7	-20.2	-15.4	62.8	1.0	18.1	6.2	13.2	2.6
26.00	25.0	-59.3	-19.4	-14.4	31.1	1.0	17.6	5.8	13.0	2.7
26.50	24.9	-57.8	-19.0	-12.4	25.9	1.0	16.9	5.3	12.7	2.7
27.00	24.4	-53.0	-17.7	-10.6	15.1	0.9	16.3	4.6	12.5	2.8
27.50	23.8	-58.1	-16.3	-9.1	28.0	0.9	14.7	3.9	11.8	2.9
28.00	22.8	-62.1	-14.5	-8.0	48.0	0.9	13.6	3.4	11.7	3.0
28.50	21.5	-68.6	-13.7	-7.3	113.6	0.8	13.3	2.8	10.9	3.1
29.00	19.9	-72.1	-13.5	-6.3	192.1	0.8	12.0	1.8	9.7	3.2
29.50	17.9	-71.8	-14.0	-5.4	217.5	0.7	11.1	1.0	8.7	3.4
30.00	16.0	-60.6	-15.5	-4.7	69.7	0.7	9.2	0.2	7.5	3.6

Typical Performance Data

NOTE: Use PDF Bookmarks to view DATA at required conditions

Definitions:

Input Return Loss = -S11 (dB)

Gain(Power Gain) = S21 (dB)

Reverse Isolation = -S12 (dB)

Output Return Loss = -S22 (dB)

TEST CONDITIONS: $V_{D1} = +4.0$ V, $V_{D2} = +4.0$ V, $V_{D3} = +4.0$ V, $I_{D1} = 10.2$ mA, $I_{D2} = 12.7$ mA, $I_{D3} = 31.1$ mA @ Temperature = +25°C

FREQ	Gain	Isolation	Input Return Loss	Output Return Loss	Stability		IP-3 Output	1dB Comp. Output	P _{SAT} Output	Noise Figure
					K	Measure				
(GHz)	(dB)	(dB)	(dB)	(dB)			(dBm)	(dBm)	(dBm)	(dB)
5.00	20.9	-67.9	-8.0	-11.6	94.0	1.1	18.2	10.6	12.3	3.1
5.50	21.2	-72.1	-9.8	-11.1	156.1	1.0	18.6	10.5	12.3	2.8
6.00	21.4	-69.4	-11.2	-11.3	116.9	1.0	19.2	10.3	12.5	2.7
6.50	21.7	-71.2	-12.5	-11.6	143.6	1.0	19.7	10.5	13.0	2.5
7.00	22.1	-69.8	-14.4	-11.5	119.2	1.0	20.4	10.4	13.3	2.3
7.50	22.6	-68.2	-16.3	-11.2	95.1	0.9	21.1	10.4	13.7	2.3
8.00	23.0	-68.0	-17.5	-10.9	89.0	0.9	21.3	10.0	13.9	2.3
8.50	23.4	-64.9	-17.3	-11.0	59.8	0.9	21.0	10.1	14.3	2.3
9.00	23.7	-66.0	-15.6	-11.2	66.1	0.9	22.2	10.2	14.7	2.2
9.50	23.9	-67.1	-13.7	-11.4	72.4	1.0	22.1	10.1	15.0	2.2
10.00	24.0	-65.7	-12.2	-11.2	60.2	1.0	21.9	10.0	15.2	2.2
10.50	24.0	-63.7	-11.3	-11.0	46.6	1.0	21.4	10.0	15.4	2.2
11.00	24.0	-64.1	-10.8	-11.0	48.2	1.0	21.9	9.8	15.3	2.3
11.50	24.1	-62.2	-10.6	-11.4	38.8	1.0	21.5	9.7	15.3	2.2
12.00	24.1	-63.7	-10.5	-12.1	46.4	1.0	20.7	9.8	15.5	2.3
12.50	23.9	-65.5	-10.5	-12.5	58.7	1.0	21.3	9.8	15.5	2.3
13.00	23.8	-77.4	-11.1	-12.1	237.7	1.0	21.4	9.7	15.4	2.3
13.50	23.7	-72.0	-11.5	-11.2	128.5	1.0	20.5	9.6	15.3	2.3
14.00	23.2	-67.7	-11.7	-11.1	82.6	1.0	21.0	10.3	15.2	2.3
14.50	23.0	-68.2	-11.5	-10.8	89.1	1.0	21.8	11.0	15.0	2.4
15.00	23.0	-63.6	-10.6	-11.3	52.6	1.0	22.9	11.3	15.1	2.5
15.50	22.7	-67.0	-9.9	-11.8	79.7	1.0	22.1	11.6	15.2	2.5
16.00	22.9	-64.7	-9.6	-12.5	59.8	1.0	23.0	11.8	15.2	2.5
16.50	23.0	-67.9	-9.6	-12.6	86.6	1.0	22.8	11.7	15.1	2.5
17.00	23.2	-63.3	-10.1	-12.1	50.6	1.0	23.0	11.5	15.2	2.5
17.50	23.3	-61.4	-10.7	-11.6	40.4	1.0	23.0	11.6	15.1	2.5
18.00	23.7	-61.5	-11.0	-11.6	39.6	1.0	24.1	11.4	14.7	2.5
18.50	24.1	-62.0	-11.1	-12.2	40.4	1.0	22.9	11.3	14.9	2.5
19.00	24.4	-61.7	-11.0	-13.4	38.2	1.0	23.1	11.4	15.3	2.6
19.50	24.7	-65.1	-11.0	-14.1	55.4	1.0	23.2	11.5	15.3	2.5
20.00	25.0	-60.8	-11.3	-14.0	33.1	1.0	23.1	11.0	15.0	2.5
20.50	25.3	-60.6	-11.7	-14.2	31.6	1.0	23.5	11.0	15.1	2.5
21.00	25.6	-69.3	-12.1	-15.6	84.5	1.0	22.7	11.1	15.4	2.4
21.50	25.9	-69.5	-11.9	-19.0	84.7	1.1	23.4	10.9	15.2	2.4
22.00	26.1	-69.3	-11.5	-24.3	81.5	1.1	22.4	10.6	15.0	2.4
22.50	26.3	-76.3	-11.3	-23.8	178.1	1.1	22.6	10.3	15.1	2.4
23.00	26.4	-67.1	-11.6	-21.0	61.4	1.1	21.7	10.1	14.8	2.4
23.50	26.6	-75.6	-12.7	-19.3	163.4	1.0	22.5	9.8	14.4	2.4
24.00	26.7	-69.5	-14.4	-17.6	80.5	1.0	22.9	9.5	14.5	2.4
24.50	26.7	-71.1	-16.5	-16.7	98.3	1.0	22.1	9.3	14.8	2.4
25.00	26.9	-71.3	-19.1	-15.9	99.8	1.0	22.5	9.1	14.6	2.4
25.50	26.8	-64.1	-21.3	-15.3	44.3	1.0	21.8	8.7	14.4	2.4
26.00	26.5	-61.7	-20.5	-14.3	34.6	1.0	21.5	8.3	14.1	2.4
26.50	26.5	-57.2	-20.2	-12.4	20.3	1.0	20.9	7.9	13.9	2.6
27.00	26.2	-63.5	-18.7	-10.7	41.7	0.9	19.8	7.3	13.7	2.6
27.50	25.7	-59.6	-17.1	-9.1	27.1	0.9	18.9	6.6	13.1	2.7
28.00	24.7	-61.3	-14.8	-7.8	34.7	0.9	17.6	6.2	12.9	2.7
28.50	23.5	-56.9	-13.6	-7.0	23.1	0.8	16.8	5.6	12.2	2.8
29.00	21.9	-65.3	-13.2	-6.0	68.1	0.8	15.8	4.6	11.0	2.9
29.50	19.8	-57.8	-13.6	-5.1	33.7	0.7	14.7	3.9	10.2	3.1
30.00	17.9	-60.9	-15.1	-4.4	56.8	0.7	13.1	3.0	9.0	3.3

Typical Performance Data

NOTE: Use PDF Bookmarks to view DATA at required conditions

Definitions:

Input Return Loss = -S11 (dB)

Gain(Power Gain) = S21 (dB)

Reverse Isolation = -S12 (dB)

Output Return Loss = -S22 (dB)

TEST CONDITIONS: $V_{D1} = +5.0\text{ V}$, $V_{D2} = +5.0\text{ V}$, $V_{D3} = +5.0\text{ V}$, $I_{D1} = 13.5\text{ mA}$, $I_{D2} = 17.8\text{ mA}$, $I_{D3} = 42.9\text{ mA}$ @ Temperature = +25°C

FREQ	Gain	Isolation	Input Return Loss	Output Return Loss	Stability		IP-3 Output	1dB Comp. Output	P _{SAT} Output	Noise Figure
					K	Measure				
(GHz)	(dB)	(dB)	(dB)	(dB)	K	Measure	(dBm)	(dBm)	(dBm)	(dB)
5.00	22.5	-61.6	-8.8	-11.3	39.1	1.0	20.3	12.3	14.0	2.8
5.50	22.6	-71.7	-10.8	-10.8	128.1	1.0	21.3	12.7	14.1	2.6
6.00	22.8	-67.4	-12.1	-11.0	79.6	1.0	21.9	12.8	14.3	2.4
6.50	23.1	-67.5	-13.6	-11.3	81.0	1.0	21.7	13.1	14.8	2.3
7.00	23.5	-70.1	-15.7	-11.2	105.6	0.9	23.2	13.2	15.0	2.2
7.50	24.0	-67.8	-18.1	-10.8	77.6	0.9	24.0	13.4	15.5	2.1
8.00	24.4	-67.4	-19.4	-10.6	71.1	0.9	24.5	13.1	15.6	2.1
8.50	24.7	-66.5	-18.8	-10.7	61.1	0.9	24.4	13.1	16.0	2.1
9.00	25.0	-68.3	-16.7	-10.9	72.7	0.9	23.9	13.2	16.3	2.0
9.50	25.3	-64.0	-14.5	-11.0	43.1	1.0	24.8	13.3	16.6	2.0
10.00	25.4	-66.7	-12.8	-10.9	57.4	1.0	25.2	13.1	16.8	2.1
10.50	25.4	-64.0	-11.8	-10.7	41.2	1.0	25.3	13.2	16.9	2.0
11.00	25.4	-64.9	-11.3	-10.7	45.1	1.0	25.5	12.9	16.8	2.1
11.50	25.5	-66.8	-11.1	-11.1	55.9	1.0	23.9	12.8	16.9	2.1
12.00	25.5	-64.1	-11.1	-11.7	41.8	1.0	24.5	13.1	17.1	2.1
12.50	25.4	-66.1	-11.0	-12.1	53.7	1.0	24.4	13.1	17.2	2.1
13.00	25.2	-74.4	-11.7	-11.8	142.7	1.0	24.4	12.8	17.0	2.1
13.50	25.1	-69.3	-12.2	-10.9	80.3	1.0	24.5	12.9	16.7	2.2
14.00	24.6	-68.3	-12.3	-10.8	76.0	1.0	23.7	13.4	16.6	2.2
14.50	24.5	-62.9	-12.2	-10.5	41.2	1.0	24.5	14.1	16.4	2.2
15.00	24.4	-63.7	-11.2	-10.9	45.3	1.0	24.5	14.4	16.5	2.3
15.50	24.1	-66.3	-10.4	-11.3	63.1	1.0	24.4	14.7	16.7	2.3
16.00	24.3	-67.0	-10.1	-11.9	67.1	1.0	24.2	14.9	16.8	2.4
16.50	24.5	-62.3	-10.2	-12.0	38.6	1.0	26.0	14.8	16.7	2.3
17.00	24.6	-66.8	-10.7	-11.4	63.7	1.0	25.0	14.8	16.9	2.4
17.50	24.7	-62.7	-11.3	-11.0	39.7	1.0	25.3	14.8	16.8	2.4
18.00	25.1	-65.6	-11.7	-10.8	53.5	1.0	24.9	14.5	16.4	2.3
18.50	25.6	-63.1	-11.8	-11.2	38.5	1.0	23.0	14.4	16.4	2.3
19.00	26.0	-63.8	-11.7	-12.1	40.5	1.0	23.7	14.6	16.8	2.3
19.50	26.3	-62.3	-11.7	-12.8	33.2	1.0	22.9	14.7	16.9	2.3
20.00	26.5	-66.3	-12.0	-12.8	51.9	1.0	23.9	14.1	16.5	2.3
20.50	26.8	-65.7	-12.6	-13.0	47.3	1.0	23.6	14.0	16.6	2.3
21.00	27.2	-67.6	-13.0	-14.2	58.0	1.0	23.4	14.3	16.9	2.2
21.50	27.5	-64.7	-12.8	-17.2	40.6	1.0	23.1	13.9	16.7	2.2
22.00	27.8	-66.7	-12.2	-22.1	50.1	1.1	22.3	13.6	16.5	2.2
22.50	27.9	-74.3	-11.9	-23.6	118.7	1.1	22.4	13.6	16.6	2.2
23.00	28.0	-75.3	-12.1	-21.1	132.3	1.1	21.9	13.4	16.2	2.2
23.50	28.3	-70.1	-13.4	-19.4	71.4	1.0	21.9	12.9	15.8	2.2
24.00	28.4	-67.3	-15.1	-17.4	51.4	1.0	21.5	12.8	15.9	2.2
24.50	28.5	-80.5	-17.4	-16.4	236.9	1.0	22.3	12.7	16.3	2.2
25.00	28.6	-72.1	-20.4	-15.5	89.4	1.0	22.2	12.6	16.2	2.2
25.50	28.7	-62.1	-23.2	-14.8	28.1	1.0	22.7	12.2	16.0	2.2
26.00	28.5	-63.3	-22.1	-14.0	33.3	1.0	22.8	11.9	15.8	2.2
26.50	28.5	-62.2	-22.1	-12.1	28.2	0.9	21.2	11.5	15.7	2.3
27.00	28.4	-60.0	-20.2	-10.5	21.5	0.9	22.6	11.1	15.5	2.4
27.50	28.2	-62.5	-18.3	-8.8	28.1	0.9	22.8	10.5	14.9	2.4
28.00	27.4	-59.2	-15.3	-7.4	19.7	0.8	22.4	10.3	14.9	2.5
28.50	26.3	-59.8	-13.5	-6.5	22.5	0.8	22.1	9.8	14.2	2.6
29.00	24.7	-68.1	-12.7	-5.5	64.5	0.8	21.4	8.9	13.0	2.7
29.50	22.6	-65.8	-12.8	-4.7	58.7	0.7	20.9	8.3	12.4	2.8
30.00	20.5	-60.8	-14.3	-4.0	38.6	0.6	21.6	7.3	11.3	3.0

Typical Performance Data

NOTE: Use PDF Bookmarks to view DATA at required conditions

Definitions:

Input Return Loss = -S11 (dB)

Gain(Power Gain) = S21 (dB)

Reverse Isolation = -S12 (dB)

Output Return Loss = -S22 (dB)

TEST CONDITIONS: $V_{D1} = +3.5\text{ V}$, $V_{D2} = +3.5\text{ V}$, $V_{D3} = +3.5\text{ V}$, $I_{D1} = 9.0\text{ mA}$, $I_{D2} = 11.5\text{ mA}$, $I_{D3} = 27.2\text{ mA}$ @ Temperature = -45°C

FREQ	Gain	Isolation	Input Return Loss	Output Return Loss	Stability		IP-3 Output	1dB Comp. Output	P _{SAT} Output	Noise Figure
					K	Measure				
(GHz)	(dB)	(dB)	(dB)	(dB)	K	Measure	(dBm)	(dBm)	(dBm)	(dB)
5.00	21.9	-68.5	-7.5	-11.4	86.4	1.1	16.4	7.2	11.8	2.4
5.50	22.2	-73.4	-9.3	-11.1	158.0	1.0	16.9	7.3	11.8	2.2
6.00	22.4	-63.9	-10.8	-11.4	54.1	1.0	17.3	7.5	11.9	2.1
6.50	22.7	-67.0	-12.5	-11.3	77.4	1.0	17.8	8.5	12.3	1.9
7.00	23.1	-64.7	-14.6	-10.9	57.7	0.9	18.9	8.5	12.4	1.8
7.50	23.5	-65.5	-16.8	-10.5	61.4	0.9	19.4	8.9	12.8	1.7
8.00	23.9	-64.9	-18.1	-10.3	54.5	0.9	19.3	8.6	13.0	1.6
8.50	24.3	-68.7	-17.8	-10.6	81.2	0.9	19.2	8.6	13.4	1.6
9.00	24.6	-66.0	-16.1	-11.0	58.2	0.9	20.1	8.6	13.9	1.6
9.50	24.8	-69.5	-14.1	-11.1	83.9	1.0	19.8	8.6	14.2	1.6
10.00	24.9	-67.2	-12.4	-11.0	62.1	1.0	19.7	8.4	14.4	1.6
10.50	25.0	-63.3	-11.3	-10.7	38.6	1.0	20.3	8.5	14.5	1.6
11.00	25.0	-63.8	-10.8	-10.7	40.5	1.0	19.8	8.2	14.4	1.6
11.50	25.1	-62.3	-10.4	-11.2	33.8	1.0	19.0	8.1	14.5	1.6
12.00	25.1	-63.5	-10.4	-11.6	38.9	1.0	19.2	8.4	14.5	1.6
12.50	25.0	-62.9	-10.4	-12.1	37.4	1.0	19.6	8.3	14.6	1.6
13.00	24.8	-85.6	-11.2	-11.7	528.8	1.0	19.2	8.1	14.5	1.6
13.50	24.8	-66.0	-11.7	-11.0	55.1	1.0	19.0	8.1	14.6	1.7
14.00	24.5	-69.0	-11.4	-10.7	80.5	1.0	19.4	8.7	14.5	1.7
14.50	24.1	-63.8	-10.9	-11.1	45.9	1.0	20.9	9.6	14.4	1.7
15.00	24.1	-63.3	-10.0	-11.5	43.2	1.0	21.8	10.0	14.5	1.7
15.50	23.7	-63.9	-9.6	-11.7	48.1	1.0	20.9	10.3	14.6	1.8
16.00	24.0	-67.7	-9.9	-11.8	72.8	1.0	21.4	10.6	14.5	1.8
16.50	24.1	-64.1	-10.1	-11.9	47.8	1.0	22.5	10.4	14.5	1.8
17.00	24.2	-64.2	-10.1	-11.6	47.8	1.0	21.7	10.4	14.5	1.8
17.50	24.3	-62.2	-10.0	-11.5	37.5	1.0	21.5	10.4	14.4	1.8
18.00	24.6	-59.8	-10.0	-11.3	27.5	1.0	21.2	10.1	14.1	1.8
18.50	25.0	-61.6	-10.7	-11.6	32.8	1.0	21.3	10.2	14.3	1.8
19.00	25.5	-63.0	-11.3	-12.7	37.7	1.0	22.1	10.4	14.8	1.8
19.50	25.8	-63.1	-11.2	-13.5	37.4	1.0	22.2	10.4	14.8	1.8
20.00	26.0	-61.8	-10.9	-13.6	31.4	1.0	21.8	10.0	14.5	1.7
20.50	26.3	-60.9	-10.8	-13.5	27.4	1.0	21.9	9.9	14.7	1.8
21.00	26.7	-65.9	-11.5	-14.3	48.1	1.0	21.5	10.2	15.0	1.7
21.50	27.0	-70.2	-12.1	-17.0	77.6	1.0	21.6	10.0	14.8	1.6
22.00	27.4	-66.1	-11.9	-23.5	47.6	1.1	21.4	9.8	14.8	1.6
22.50	27.5	-72.1	-11.2	-24.2	92.5	1.1	21.3	9.5	14.8	1.6
23.00	27.6	-75.5	-10.9	-21.1	134.3	1.1	21.5	9.4	14.4	1.6
23.50	27.9	-64.5	-11.8	-20.0	37.7	1.1	20.6	9.0	14.2	1.6
24.00	28.1	-74.0	-13.7	-19.2	111.6	1.0	20.7	8.9	14.3	1.7
24.50	28.2	-69.6	-15.8	-18.4	68.1	1.0	20.7	8.9	14.4	1.6
25.00	28.4	-68.6	-18.2	-17.3	59.7	1.0	20.3	8.6	14.1	1.6
25.50	28.5	-69.2	-20.5	-16.2	64.0	1.0	19.5	8.2	13.8	1.6
26.00	28.2	-62.3	-20.2	-15.2	29.9	1.0	19.5	7.8	13.6	1.7
26.50	28.4	-60.3	-20.8	-13.5	23.1	1.0	18.8	7.6	13.4	1.7
27.00	28.2	-55.6	-19.2	-11.6	13.2	0.9	17.8	7.1	13.3	1.8
27.50	27.9	-57.2	-18.3	-9.5	15.6	0.9	17.5	6.5	12.9	1.9
28.00	27.5	-59.2	-15.3	-7.7	19.3	0.9	16.0	6.3	13.0	1.9
28.50	26.4	-58.6	-13.3	-6.8	19.2	0.8	16.4	5.8	12.2	1.9
29.00	25.1	-57.7	-12.9	-5.8	18.5	0.8	14.9	4.9	11.2	2.0
29.50	23.0	-60.0	-12.8	-4.6	27.2	0.7	13.5	4.3	10.5	2.1
30.00	21.0	-60.4	-13.4	-3.6	31.2	0.6	11.9	3.5	9.5	2.3

Typical Performance Data

NOTE: Use PDF Bookmarks to view DATA at required conditions

Definitions:

Input Return Loss = -S11 (dB)

Gain(Power Gain) = S21 (dB)

Reverse Isolation = -S12 (dB)

Output Return Loss = -S22 (dB)

TEST CONDITIONS: $V_{D1} = +4.0$ V, $V_{D2} = +4.0$ V, $V_{D3} = +4.0$ V, $I_{D1} = 10.5$ mA, $I_{D2} = 13.7$ mA, $I_{D3} = 32.6$ mA @ Temperature = -45°C

FREQ	Gain	Isolation	Input Return Loss	Output Return Loss	Stability		IP-3 Output	1dB Comp. Output	P _{SAT} Output	Noise Figure
					K	Measure				
(GHz)	(dB)	(dB)	(dB)	(dB)	K	Measure	(dBm)	(dBm)	(dBm)	(dB)
5.00	22.8	-72.5	-8.0	-11.1	126.0	1.1	18.3	9.3	12.9	2.2
5.50	23.0	-66.6	-9.8	-10.9	66.4	1.0	18.9	9.5	13.0	1.9
6.00	23.1	-70.3	-11.3	-11.2	105.2	1.0	19.8	9.7	13.1	1.9
6.50	23.4	-72.0	-13.1	-11.1	127.9	1.0	19.8	10.2	13.5	1.7
7.00	23.8	-67.2	-15.4	-10.7	71.2	0.9	21.2	10.2	13.7	1.6
7.50	24.2	-66.5	-17.8	-10.3	63.5	0.9	21.0	10.6	14.1	1.6
8.00	24.6	-67.9	-19.2	-10.2	71.1	0.9	21.7	10.3	14.3	1.5
8.50	25.0	-61.6	-18.7	-10.5	33.3	0.9	22.2	10.4	14.7	1.5
9.00	25.3	-65.2	-16.8	-10.8	48.9	0.9	22.3	10.5	15.1	1.5
9.50	25.5	-69.8	-14.5	-10.9	79.3	0.9	22.1	10.4	15.4	1.4
10.00	25.7	-65.9	-12.7	-10.7	49.3	1.0	22.0	10.3	15.7	1.4
10.50	25.7	-63.1	-11.6	-10.5	35.0	1.0	21.9	10.4	15.8	1.5
11.00	25.8	-63.5	-11.0	-10.6	35.8	1.0	23.0	10.2	15.7	1.5
11.50	25.8	-62.7	-10.6	-11.0	32.4	1.0	22.0	10.1	15.8	1.5
12.00	25.9	-63.4	-10.7	-11.5	35.4	1.0	21.4	10.4	15.9	1.5
12.50	25.7	-62.1	-10.7	-11.9	31.2	1.0	22.1	10.3	15.9	1.5
13.00	25.6	-68.9	-11.6	-11.5	71.1	1.0	21.8	10.0	15.8	1.5
13.50	25.6	-70.3	-12.1	-10.8	83.7	1.0	20.9	10.0	15.8	1.5
14.00	25.2	-65.2	-11.7	-10.6	47.8	1.0	21.9	10.7	15.7	1.6
14.50	24.8	-62.7	-11.1	-10.9	37.3	1.0	22.6	11.4	15.6	1.6
15.00	24.8	-64.4	-10.1	-11.4	45.2	1.0	23.9	11.9	15.7	1.6
15.50	24.4	-62.0	-9.8	-11.5	35.7	1.0	23.6	12.2	15.8	1.6
16.00	24.7	-62.5	-10.2	-11.6	36.8	1.0	24.0	12.5	15.7	1.6
16.50	24.9	-64.3	-10.5	-11.6	44.9	1.0	24.3	12.3	15.7	1.6
17.00	25.0	-66.0	-10.4	-11.3	53.7	1.0	24.4	12.3	15.7	1.7
17.50	25.0	-62.0	-10.2	-11.2	33.6	1.0	23.7	12.4	15.5	1.7
18.00	25.3	-62.3	-10.2	-11.0	33.5	1.0	23.5	12.1	15.3	1.7
18.50	25.8	-60.0	-11.0	-11.2	25.1	1.0	23.3	12.2	15.4	1.6
19.00	26.3	-62.6	-11.8	-12.1	32.7	1.0	24.6	12.3	15.9	1.6
19.50	26.6	-64.5	-11.6	-12.9	39.6	1.0	25.3	12.3	15.9	1.6
20.00	26.8	-61.4	-11.2	-13.0	27.2	1.0	24.5	11.8	15.6	1.6
20.50	27.1	-63.9	-11.1	-13.0	35.0	1.0	24.3	11.7	15.8	1.6
21.00	27.5	-75.8	-11.8	-13.8	136.7	1.0	24.6	12.0	16.1	1.6
21.50	27.9	-67.6	-12.6	-16.2	52.8	1.0	24.9	11.7	15.8	1.5
22.00	28.2	-68.0	-12.4	-22.2	54.0	1.1	24.2	11.4	15.8	1.5
22.50	28.3	-68.3	-11.5	-23.9	54.7	1.1	23.7	11.3	15.8	1.5
23.00	28.4	-81.0	-11.1	-21.2	231.0	1.1	23.0	11.0	15.3	1.4
23.50	28.7	-76.7	-12.0	-20.1	139.6	1.1	23.5	10.7	15.1	1.5
24.00	29.0	-70.2	-14.0	-19.3	65.4	1.0	22.9	10.7	15.2	1.5
24.50	29.0	-75.8	-16.2	-18.3	125.5	1.0	23.4	10.6	15.5	1.5
25.00	29.3	-62.6	-18.6	-17.0	27.3	1.0	23.3	10.3	15.2	1.4
25.50	29.4	-72.0	-21.2	-15.7	80.3	1.0	23.6	9.9	15.0	1.4
26.00	29.1	-58.9	-21.0	-14.9	18.2	1.0	23.2	9.8	14.8	1.4
26.50	29.3	-61.6	-22.0	-13.3	23.8	1.0	22.5	9.5	14.6	1.5
27.00	29.2	-58.0	-20.3	-11.5	15.5	0.9	22.8	8.9	14.5	1.6
27.50	29.0	-63.8	-19.1	-9.4	29.4	0.9	20.1	8.6	14.1	1.6
28.00	28.7	-60.0	-15.3	-7.5	18.1	0.8	20.5	8.3	14.2	1.6
28.50	27.7	-57.6	-13.0	-6.5	14.5	0.8	20.2	7.8	13.3	1.7
29.00	26.4	-60.3	-12.4	-5.6	21.1	0.8	18.3	7.0	12.4	1.7
29.50	24.2	-60.7	-12.2	-4.4	24.8	0.7	17.5	6.5	11.7	1.9
30.00	22.2	-60.2	-12.9	-3.4	25.6	0.6	15.5	5.6	10.7	2.0

Typical Performance Data

NOTE: Use PDF Bookmarks to view DATA at required conditions

Definitions:

Input Return Loss = -S11 (dB)

Gain(Power Gain) = S21 (dB)

Reverse Isolation = -S12 (dB)

Output Return Loss = -S22 (dB)

TEST CONDITIONS: $V_{D1} = +3.5\text{ V}$, $V_{D2} = +3.5\text{ V}$, $V_{D3} = +3.5\text{ V}$, $I_{D1} = 8.3\text{ mA}$, $I_{D2} = 9.7\text{ mA}$, $I_{D3} = 24.6\text{ mA}$ @ Temperature = 85°C

FREQ	Gain	Isolation	Input Return Loss	Output Return Loss	Stability		IP-3 Output	1dB Comp. Output	P _{SAT} Output	Noise Figure
					K	Measure				
(GHz)	(dB)	(dB)	(dB)	(dB)	K	Measure	(dBm)	(dBm)	(dBm)	(dB)
5.00	17.9	-78.7	-7.5	-12.4	459.9	1.1	15.8	9.0	10.4	4.3
5.50	18.4	-65.0	-9.1	-12.0	94.7	1.1	15.7	9.1	10.5	3.9
6.00	18.8	-69.5	-10.3	-12.3	159.2	1.0	16.0	9.0	10.7	3.7
6.50	19.2	-75.1	-11.5	-12.3	302.3	1.0	16.3	9.0	11.1	3.4
7.00	19.6	-66.3	-13.0	-11.9	106.3	1.0	17.2	8.5	11.4	3.3
7.50	20.0	-62.6	-14.5	-11.5	67.3	1.0	17.5	8.3	11.8	3.2
8.00	20.4	-64.8	-15.3	-11.5	82.8	1.0	17.8	7.9	12.0	3.1
8.50	20.8	-68.1	-15.0	-11.9	117.7	1.0	17.9	7.9	12.4	3.1
9.00	21.1	-70.1	-13.9	-12.3	144.4	1.0	18.2	7.8	12.8	3.1
9.50	21.2	-63.8	-12.7	-12.2	67.8	1.0	18.1	7.7	13.1	3.0
10.00	21.3	-63.2	-11.6	-11.7	61.8	1.0	17.7	7.6	13.3	3.1
10.50	21.3	-71.1	-10.9	-11.3	150.1	1.0	18.0	7.5	13.5	3.1
11.00	21.3	-63.3	-10.3	-11.5	60.8	1.0	18.0	7.3	13.4	3.1
11.50	21.3	-64.2	-9.9	-12.1	67.8	1.0	17.3	7.2	13.5	3.1
12.00	21.3	-63.9	-9.9	-12.8	66.4	1.0	16.8	7.4	13.6	3.2
12.50	21.1	-66.1	-9.9	-13.1	87.7	1.0	17.3	7.2	13.6	3.2
13.00	21.0	-70.2	-10.4	-12.5	143.6	1.0	17.1	7.1	13.5	3.2
13.50	20.8	-71.6	-10.8	-11.6	170.8	1.0	16.9	7.3	13.5	3.3
14.00	20.4	-75.1	-11.0	-11.5	272.3	1.0	17.5	8.1	13.5	3.3
14.50	20.3	-65.9	-10.8	-11.3	95.4	1.0	18.6	8.7	13.3	3.3
15.00	20.1	-74.4	-10.2	-11.7	256.7	1.0	18.7	9.1	13.4	3.4
15.50	20.0	-65.8	-9.7	-12.2	95.9	1.0	18.6	9.2	13.5	3.5
16.00	20.2	-67.5	-9.3	-13.0	116.0	1.1	19.3	9.5	13.5	3.5
16.50	20.2	-65.9	-9.2	-13.3	95.5	1.1	19.3	9.3	13.5	3.5
17.00	20.4	-64.2	-9.5	-12.9	78.3	1.1	19.4	9.1	13.5	3.5
17.50	20.5	-61.0	-10.0	-12.5	53.8	1.0	19.2	9.1	13.3	3.6
18.00	20.9	-60.5	-10.5	-12.5	49.6	1.0	19.9	9.0	13.1	3.5
18.50	21.3	-66.3	-10.9	-13.4	94.3	1.0	19.4	8.9	13.4	3.5
19.00	21.6	-65.1	-11.0	-14.9	81.0	1.0	19.4	8.9	13.7	3.5
19.50	21.8	-58.9	-10.9	-15.6	38.8	1.1	19.3	9.0	13.6	3.5
20.00	22.0	-60.0	-11.0	-15.2	42.9	1.0	19.3	8.6	13.5	3.5
20.50	22.3	-65.8	-11.1	-15.4	81.6	1.0	19.2	8.3	13.6	3.4
21.00	22.6	-63.0	-11.2	-17.2	58.0	1.1	19.1	8.4	13.8	3.5
21.50	22.9	-61.7	-11.2	-21.4	49.3	1.1	19.0	8.3	13.7	3.4
22.00	23.1	-64.9	-11.1	-27.7	70.4	1.1	18.3	8.0	13.6	3.4
22.50	23.2	-65.6	-11.1	-23.6	75.3	1.1	18.4	7.7	13.6	3.4
23.00	23.3	-76.9	-11.4	-19.9	275.8	1.1	18.4	7.5	13.3	3.4
23.50	23.5	-68.2	-12.5	-17.5	100.1	1.0	18.2	7.2	13.0	3.4
24.00	23.5	-68.5	-14.4	-15.9	104.5	1.0	17.9	6.8	13.0	3.4
24.50	23.5	-77.1	-16.8	-15.4	287.3	1.0	17.5	6.5	13.1	3.4
25.00	23.5	-66.2	-19.3	-15.4	83.6	1.0	16.7	6.1	12.9	3.4
25.50	23.4	-66.0	-20.0	-15.3	83.6	1.0	16.3	5.6	12.7	3.4
26.00	22.9	-60.3	-18.1	-14.1	45.4	1.0	15.4	4.9	12.4	3.5
26.50	22.6	-64.2	-17.3	-11.9	71.2	1.0	14.8	4.4	12.0	3.7
27.00	21.9	-62.1	-16.0	-9.9	57.8	0.9	13.8	3.6	11.7	3.7
27.50	21.0	-67.9	-15.4	-8.6	120.1	0.9	12.6	3.0	10.9	3.8
28.00	19.9	-60.1	-14.7	-7.9	53.9	0.9	12.1	2.4	10.7	3.9
28.50	18.6	-68.4	-14.4	-7.5	161.6	0.9	11.4	1.7	10.0	4.1
29.00	16.9	-64.4	-14.4	-6.8	117.8	0.8	9.8	0.7	8.8	4.3
29.50	15.0	-56.6	-14.7	-5.7	55.7	0.8	8.2	-0.2	7.7	4.5
30.00	13.2	-61.6	-15.7	-4.9	114.2	0.7	6.3	-1.3	6.4	4.8

Typical Performance Data

NOTE: Use PDF Bookmarks to view DATA at required conditions

Definitions:

Input Return Loss = -S11 (dB)

Gain(Power Gain) = S21 (dB)

Reverse Isolation = -S12 (dB)

Output Return Loss = -S22 (dB)

TEST CONDITIONS: $V_{D1} = +4.0V$, $V_{D2} = +4.0V$, $V_{D3} = +4.0V$, $I_{D1} = 10.0mA$, $I_{D2} = 11.9mA$, $I_{D3} = 30.3mA$ @ Temperature = 85°C

FREQ	Gain	Isolation	Input Return Loss	Output Return Loss	Stability		IP-3 Output	1dB Comp. Output	P _{SAT} Output	Noise Figure
					K	Measure				
(GHz)	(dB)	(dB)	(dB)	(dB)	K	Measure	(dBm)	(dBm)	(dBm)	(dB)
5.00	19.3	-71.2	-8.0	-12.0	167.7	1.1	17.2	10.3	11.5	3.9
5.50	19.8	-66.0	-9.8	-11.7	92.3	1.0	17.4	10.3	11.6	3.6
6.00	20.1	-72.4	-11.0	-12.0	194.5	1.0	17.9	10.1	11.8	3.4
6.50	20.4	-69.1	-12.3	-12.0	132.2	1.0	18.4	10.1	12.3	3.2
7.00	20.9	-64.6	-13.9	-11.6	76.2	1.0	19.0	10.0	12.7	3.1
7.50	21.3	-66.9	-15.6	-11.3	95.8	1.0	19.8	10.0	13.1	3.0
8.00	21.7	-69.2	-16.5	-11.2	119.2	0.9	20.3	9.7	13.2	3.0
8.50	22.0	-63.0	-16.0	-11.6	56.9	1.0	20.4	9.7	13.6	2.9
9.00	22.3	-62.5	-14.7	-12.0	52.1	1.0	20.9	9.8	14.0	2.9
9.50	22.5	-63.8	-13.2	-11.9	58.8	1.0	20.4	9.7	14.3	2.8
10.00	22.6	-68.6	-12.1	-11.5	99.7	1.0	20.3	9.6	14.5	2.9
10.50	22.6	-65.7	-11.3	-11.1	69.7	1.0	20.5	9.5	14.6	2.9
11.00	22.6	-64.9	-10.7	-11.2	63.0	1.0	20.8	9.4	14.5	2.9
11.50	22.6	-68.0	-10.3	-11.9	90.5	1.0	20.4	9.2	14.6	2.9
12.00	22.6	-62.3	-10.3	-12.5	47.7	1.0	19.5	9.5	14.8	3.0
12.50	22.4	-64.9	-10.4	-12.8	66.5	1.0	20.2	9.3	14.8	3.0
13.00	22.3	-76.9	-10.9	-12.2	270.0	1.0	19.7	9.1	14.6	3.0
13.50	22.2	-67.0	-11.3	-11.4	86.4	1.0	19.4	9.4	14.5	3.0
14.00	21.7	-76.1	-11.5	-11.3	263.4	1.0	20.4	10.0	14.5	3.1
14.50	21.6	-66.4	-11.3	-11.1	86.6	1.0	20.9	10.8	14.4	3.1
15.00	21.5	-63.2	-10.7	-11.4	60.7	1.0	21.6	10.9	14.4	3.2
15.50	21.3	-72.2	-10.1	-11.8	173.1	1.0	21.3	11.2	14.6	3.2
16.00	21.5	-69.0	-9.7	-12.5	118.4	1.0	22.1	11.5	14.6	3.3
16.50	21.6	-65.0	-9.6	-12.8	74.0	1.1	22.3	11.3	14.5	3.3
17.00	21.7	-61.5	-9.9	-12.5	49.1	1.0	22.0	11.2	14.6	3.3
17.50	21.9	-61.9	-10.4	-12.1	51.3	1.0	22.1	11.1	14.5	3.3
18.00	22.2	-63.9	-11.0	-11.9	62.7	1.0	22.2	10.9	14.2	3.3
18.50	22.6	-64.5	-11.4	-12.6	65.7	1.0	22.3	10.9	14.4	3.3
19.00	23.0	-62.8	-11.5	-14.0	52.5	1.0	21.7	11.0	14.7	3.3
19.50	23.3	-65.2	-11.4	-14.6	67.8	1.0	21.1	11.0	14.7	3.2
20.00	23.5	-67.6	-11.5	-14.5	87.9	1.0	22.0	10.7	14.5	3.2
20.50	23.8	-63.3	-11.6	-14.6	52.1	1.0	21.7	10.4	14.6	3.2
21.00	24.1	-67.7	-11.8	-16.2	85.5	1.0	21.2	10.5	14.8	3.2
21.50	24.3	-66.3	-11.7	-19.9	71.4	1.1	21.4	10.3	14.7	3.2
22.00	24.5	-65.4	-11.5	-26.8	63.6	1.1	22.3	10.1	14.5	3.1
22.50	24.7	-72.4	-11.5	-24.1	141.1	1.1	20.8	9.8	14.5	3.2
23.00	24.8	-66.9	-11.9	-20.2	73.8	1.1	20.5	9.7	14.1	3.1
23.50	25.0	-69.1	-13.1	-17.6	93.8	1.0	20.9	9.3	13.8	3.2
24.00	25.1	-69.3	-15.0	-16.0	96.4	1.0	21.5	9.0	14.0	3.2
24.50	25.1	-69.2	-17.7	-15.3	96.9	1.0	21.2	8.8	14.2	3.2
25.00	25.2	-65.6	-20.4	-15.2	64.5	1.0	20.8	8.5	14.0	3.2
25.50	25.1	-63.7	-21.2	-15.2	52.6	1.0	20.4	8.0	13.8	3.2
26.00	24.7	-60.9	-19.3	-14.2	39.5	1.0	19.4	7.4	13.5	3.3
26.50	24.5	-62.6	-18.4	-11.9	47.8	0.9	18.8	6.9	13.2	3.4
27.00	23.9	-57.3	-17.0	-9.9	26.5	0.9	17.6	6.2	13.0	3.5
27.50	23.2	-62.5	-16.1	-8.4	50.2	0.9	16.5	5.6	12.2	3.5
28.00	22.2	-62.2	-14.9	-7.6	52.7	0.9	16.1	5.1	12.0	3.6
28.50	20.9	-58.0	-14.5	-7.2	37.0	0.8	15.4	4.6	11.3	3.7
29.00	19.2	-61.4	-14.4	-6.6	63.9	0.8	13.8	3.5	10.2	3.9
29.50	17.2	-73.5	-14.5	-5.5	297.6	0.7	12.3	2.6	9.1	4.1
30.00	15.3	-59.2	-15.5	-4.7	66.3	0.7	10.4	1.5	7.8	4.3

Typical Performance Data

NOTE: Use PDF Bookmarks to view DATA at required conditions

Definitions:

Input Return Loss = -S11 (dB)

Gain(Power Gain) = S21 (dB)

Reverse Isolation = -S12 (dB)

Output Return Loss = -S22 (dB)

TEST CONDITIONS: $V_{D1} = +3.5\text{ V}$, $V_{D2} = +3.5\text{ V}$, $V_{D3} = +3.5\text{ V}$, $I_{D1} = 8.1\text{ mA}$, $I_{D2} = 9.5\text{ mA}$, $I_{D3} = 24.4\text{ mA}$ @ Temperature = 105°C

FREQ	Gain	Isolation	Input Return Loss	Output Return Loss	Stability		IP-3 Output	1dB Comp. Output	P _{SAT} Output	Noise Figure
					K	Measure				
(GHz)	(dB)	(dB)	(dB)	(dB)	K	Measure	(dBm)	(dBm)	(dBm)	(dB)
5.00	17.3	-74.5	-7.5	-12.5	306.5	1.1	15.5	8.9	10.0	4.6
5.50	17.9	-72.3	-9.1	-12.2	235.4	1.1	15.4	9.0	10.1	4.2
6.00	18.2	-72.7	-10.2	-12.5	248.5	1.0	15.7	8.9	10.4	4.0
6.50	18.7	-72.5	-11.4	-12.5	239.3	1.0	16.0	8.9	10.9	3.7
7.00	19.1	-66.9	-12.9	-12.1	120.9	1.0	16.8	8.2	11.1	3.5
7.50	19.5	-69.5	-14.2	-11.7	157.1	1.0	17.2	8.2	11.5	3.4
8.00	19.9	-69.7	-15.0	-11.7	156.4	1.0	17.3	7.6	11.7	3.3
8.50	20.3	-69.8	-14.7	-12.1	153.1	1.0	17.3	7.6	12.1	3.3
9.00	20.5	-65.7	-13.7	-12.4	92.3	1.0	17.9	7.5	12.5	3.3
9.50	20.7	-72.3	-12.5	-12.2	193.3	1.0	17.4	7.4	12.8	3.3
10.00	20.7	-63.4	-11.5	-11.8	67.3	1.0	17.5	7.2	13.1	3.3
10.50	20.8	-68.4	-10.9	-11.5	117.4	1.0	17.7	7.3	13.2	3.3
11.00	20.8	-65.4	-10.3	-11.7	82.8	1.0	17.7	7.0	13.2	3.3
11.50	20.7	-66.9	-9.9	-12.4	98.8	1.0	17.1	7.0	13.2	3.4
12.00	20.7	-66.2	-9.8	-13.0	92.4	1.1	16.6	7.0	13.4	3.4
12.50	20.5	-67.4	-9.9	-13.1	109.6	1.0	16.8	6.8	13.4	3.4
13.00	20.4	-73.7	-10.3	-12.4	230.7	1.0	16.6	6.8	13.2	3.4
13.50	20.2	-67.6	-10.7	-11.6	116.4	1.0	16.4	7.1	13.2	3.5
14.00	19.8	-73.1	-10.9	-11.6	233.7	1.0	17.4	7.7	13.2	3.6
14.50	19.7	-65.4	-10.8	-11.4	97.0	1.0	18.3	8.5	13.1	3.6
15.00	19.6	-65.8	-10.3	-11.8	101.9	1.0	18.7	8.7	13.2	3.7
15.50	19.4	-63.9	-9.8	-12.2	83.1	1.0	18.4	9.0	13.3	3.7
16.00	19.6	-66.9	-9.4	-13.0	116.7	1.1	19.0	9.1	13.3	3.8
16.50	19.7	-64.3	-9.2	-13.5	85.6	1.1	19.1	8.9	13.3	3.8
17.00	19.8	-65.7	-9.5	-13.2	99.5	1.1	18.8	8.9	13.3	3.8
17.50	20.0	-61.5	-9.9	-12.8	61.2	1.0	18.9	8.9	13.2	3.8
18.00	20.3	-60.8	-10.5	-12.7	55.0	1.0	19.5	8.7	12.9	3.8
18.50	20.7	-59.6	-11.0	-13.5	47.2	1.0	19.1	8.7	13.2	3.8
19.00	21.0	-63.8	-11.2	-14.9	75.0	1.0	18.9	8.6	13.4	3.8
19.50	21.3	-59.9	-11.1	-15.6	46.8	1.0	19.2	8.6	13.4	3.8
20.00	21.5	-62.0	-11.1	-15.4	58.8	1.0	19.0	8.4	13.2	3.8
20.50	21.8	-62.9	-11.2	-15.7	63.5	1.0	18.8	8.1	13.3	3.7
21.00	22.1	-62.8	-11.3	-17.5	61.5	1.1	18.6	8.2	13.5	3.7
21.50	22.3	-61.5	-11.1	-21.9	52.2	1.1	18.9	7.9	13.4	3.7
22.00	22.5	-62.6	-11.0	-27.4	58.9	1.1	18.4	7.7	13.3	3.7
22.50	22.6	-71.9	-11.1	-23.0	170.1	1.1	18.1	7.4	13.3	3.7
23.00	22.7	-69.5	-11.6	-19.2	127.0	1.1	18.0	7.3	13.0	3.7
23.50	22.8	-66.6	-12.8	-16.8	90.4	1.0	17.8	6.9	12.7	3.7
24.00	22.9	-72.2	-14.8	-15.4	175.0	1.0	17.2	6.4	12.8	3.7
24.50	22.8	-70.9	-17.4	-14.9	154.4	1.0	16.9	6.2	12.9	3.7
25.00	22.8	-66.0	-19.6	-15.2	89.5	1.0	16.5	5.7	12.7	3.7
25.50	22.7	-62.5	-19.6	-15.4	61.0	1.0	15.8	5.1	12.5	3.8
26.00	22.2	-61.2	-17.7	-14.1	55.0	1.0	15.0	4.5	12.1	3.9
26.50	21.7	-60.3	-16.7	-11.8	50.7	1.0	14.3	3.9	11.7	4.0
27.00	21.1	-60.1	-15.7	-9.6	50.9	0.9	13.1	3.1	11.4	4.1
27.50	20.1	-58.2	-15.3	-8.3	43.5	0.9	11.9	2.4	10.5	4.2
28.00	19.0	-77.9	-14.9	-7.7	470.2	0.9	11.2	1.8	10.3	4.3
28.50	17.7	-62.1	-14.8	-7.6	88.4	0.9	10.5	1.3	9.6	4.5
29.00	16.0	-63.7	-15.0	-7.0	125.4	0.8	9.0	0.2	8.4	4.7
29.50	14.1	-60.1	-15.0	-5.9	96.0	0.8	7.6	-0.8	7.3	5.0
30.00	12.2	-60.5	-15.7	-5.0	115.5	0.7	5.4	-1.9	5.9	5.3

Typical Performance Data

NOTE: Use PDF Bookmarks to view DATA at required conditions

Definitions:

Input Return Loss = -S11 (dB)

Gain(Power Gain) = S21 (dB)

Reverse Isolation = -S12 (dB)

Output Return Loss = -S22 (dB)

TEST CONDITIONS: $V_{D1} = +4.0$ V, $V_{D2} = +4.0$ V, $V_{D3} = +4.0$ V, $I_{D1} = 9.9$ mA, $I_{D2} = 11.8$ mA, $I_{D3} = 30.0$ mA @ Temperature = 105°C

FREQ	Gain	Isolation	Input Return Loss	Output Return Loss	Stability		IP-3 Output	1dB Comp. Output	P _{SAT} Output	Noise Figure
					K	Measure				
(GHz)	(dB)	(dB)	(dB)	(dB)	K	Measure	(dBm)	(dBm)	(dBm)	(dB)
5.00	18.8	-67.0	-8.0	-12.1	110.1	1.1	17.0	10.0	11.2	4.3
5.50	19.3	-70.6	-9.7	-11.8	168.2	1.0	17.0	10.0	11.3	3.9
6.00	19.6	-70.3	-10.9	-12.2	163.5	1.0	17.6	9.9	11.6	3.7
6.50	20.0	-77.4	-12.2	-12.2	362.5	1.0	18.0	9.8	12.1	3.4
7.00	20.4	-66.0	-13.8	-11.8	95.1	1.0	18.9	9.8	12.4	3.3
7.50	20.8	-71.4	-15.3	-11.4	170.8	1.0	19.6	9.7	12.7	3.2
8.00	21.2	-64.9	-16.1	-11.4	77.1	0.9	19.4	9.4	12.9	3.1
8.50	21.6	-69.3	-15.6	-11.8	124.5	1.0	19.8	9.4	13.3	3.1
9.00	21.8	-65.1	-14.4	-12.2	74.8	1.0	20.4	9.5	13.7	3.1
9.50	22.0	-64.2	-13.1	-11.9	65.3	1.0	20.0	9.4	13.9	3.1
10.00	22.1	-66.9	-12.0	-11.5	86.7	1.0	19.7	9.3	14.1	3.1
10.50	22.1	-67.6	-11.3	-11.2	92.1	1.0	20.6	9.2	14.3	3.1
11.00	22.1	-72.0	-10.7	-11.4	151.9	1.0	20.7	9.1	14.2	3.1
11.50	22.1	-66.5	-10.3	-12.1	81.0	1.0	19.8	8.9	14.3	3.1
12.00	22.1	-67.0	-10.2	-12.7	87.7	1.0	19.2	9.1	14.5	3.2
12.50	21.9	-66.6	-10.3	-12.8	86.0	1.0	19.4	8.9	14.4	3.2
13.00	21.8	-72.5	-10.8	-12.2	172.6	1.0	19.2	8.8	14.3	3.2
13.50	21.6	-64.7	-11.2	-11.4	71.3	1.0	19.2	9.1	14.1	3.3
14.00	21.2	-75.8	-11.4	-11.4	270.8	1.0	19.4	9.8	14.2	3.3
14.50	21.1	-65.4	-11.3	-11.2	82.7	1.0	20.9	10.4	14.1	3.3
15.00	21.0	-68.1	-10.7	-11.5	114.3	1.0	21.1	10.6	14.2	3.4
15.50	20.8	-64.4	-10.2	-11.9	75.9	1.0	20.8	10.9	14.3	3.5
16.00	21.0	-68.2	-9.8	-12.5	115.2	1.0	21.5	11.2	14.4	3.5
16.50	21.1	-65.4	-9.7	-13.0	83.1	1.1	21.9	11.0	14.3	3.5
17.00	21.2	-62.5	-9.9	-12.7	58.8	1.0	21.3	10.8	14.4	3.5
17.50	21.4	-61.7	-10.3	-12.3	53.3	1.0	21.4	10.8	14.2	3.5
18.00	21.7	-60.6	-10.9	-12.1	45.9	1.0	22.3	10.8	13.9	3.5
18.50	22.1	-62.9	-11.4	-12.7	58.3	1.0	21.7	10.6	14.1	3.5
19.00	22.5	-61.8	-11.7	-14.0	50.2	1.0	21.7	10.7	14.4	3.5
19.50	22.8	-62.3	-11.6	-14.7	52.6	1.0	21.3	10.8	14.4	3.5
20.00	23.0	-62.9	-11.6	-14.7	54.8	1.0	21.2	10.3	14.2	3.5
20.50	23.2	-62.4	-11.7	-14.9	50.4	1.0	21.5	10.3	14.3	3.5
21.00	23.6	-64.5	-11.8	-16.5	63.1	1.0	21.1	10.3	14.5	3.4
21.50	23.8	-65.0	-11.6	-20.5	65.9	1.1	21.0	10.1	14.4	3.4
22.00	24.0	-66.2	-11.4	-26.7	74.4	1.1	21.3	9.8	14.2	3.4
22.50	24.1	-70.0	-11.5	-23.5	114.6	1.1	20.9	9.5	14.2	3.4
23.00	24.3	-78.4	-12.0	-19.4	299.3	1.1	20.2	9.3	13.9	3.4
23.50	24.4	-79.0	-13.3	-16.9	317.6	1.0	21.5	9.1	13.6	3.4
24.00	24.5	-83.4	-15.4	-15.4	528.5	1.0	20.8	8.7	13.7	3.5
24.50	24.5	-74.0	-18.3	-14.8	182.8	1.0	20.8	8.5	13.9	3.4
25.00	24.6	-64.2	-20.7	-15.1	59.5	1.0	19.8	8.1	13.7	3.4
25.50	24.5	-63.0	-20.7	-15.3	53.0	1.0	19.7	7.7	13.5	3.5
26.00	24.1	-64.1	-18.6	-14.2	62.3	1.0	18.7	7.1	13.3	3.6
26.50	23.7	-60.5	-17.8	-11.8	40.9	0.9	18.4	6.4	12.8	3.7
27.00	23.2	-59.7	-16.5	-9.6	38.3	0.9	17.0	5.7	12.6	3.8
27.50	22.3	-56.7	-15.8	-8.1	28.4	0.9	15.3	5.1	11.8	3.8
28.00	21.3	-59.2	-15.1	-7.5	41.5	0.8	14.4	4.6	11.6	3.9
28.50	19.9	-55.8	-14.9	-7.3	32.3	0.8	14.6	4.1	11.0	4.1
29.00	18.3	-59.3	-14.8	-6.8	57.2	0.8	12.9	3.0	9.8	4.3
29.50	16.3	-62.8	-14.7	-5.7	99.6	0.8	11.5	2.1	8.8	4.5
30.00	14.4	-69.3	-15.5	-4.8	244.0	0.7	9.6	0.9	7.5	4.8

Typical Performance Curves

Note: All data taken at nominal condition $V_{DD} = +4$ V unless noted otherwise.

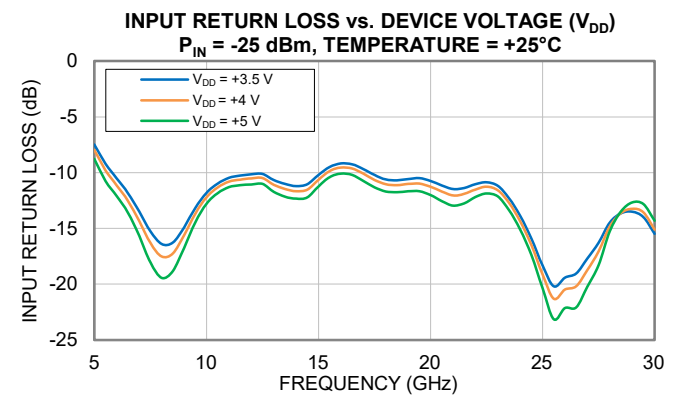
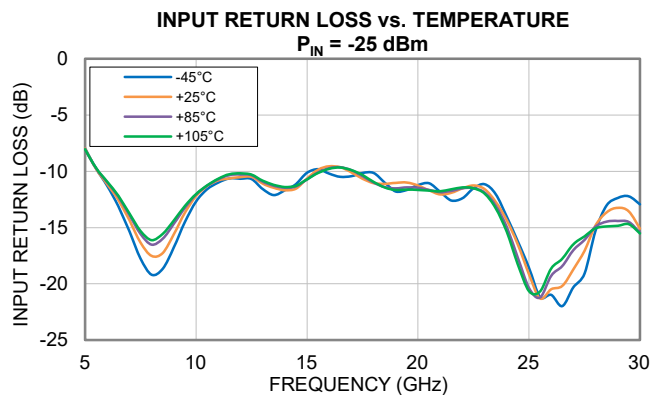
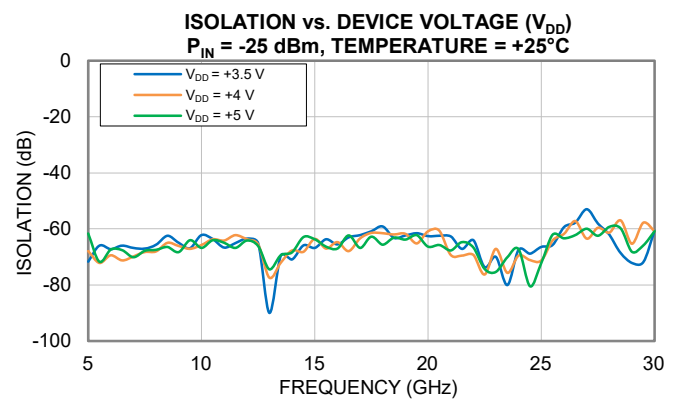
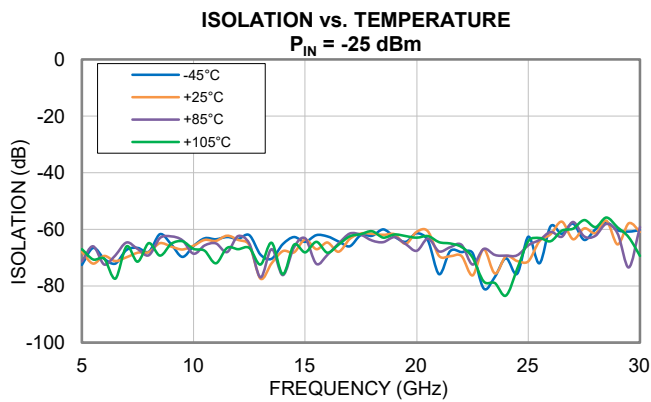
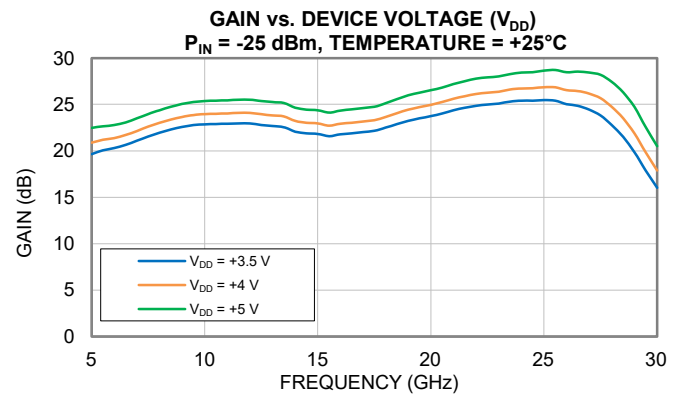
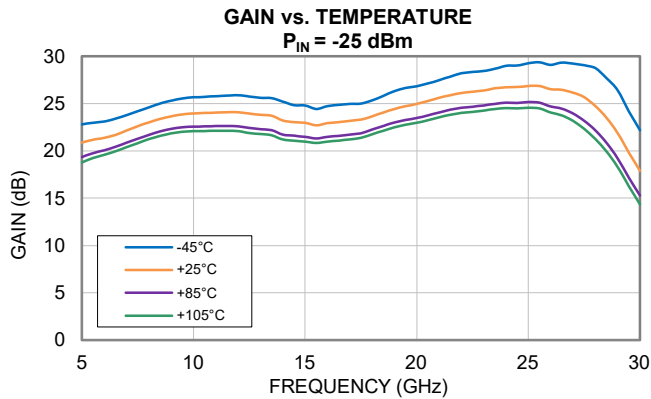

Typical Performance Curves

Note: All data taken at nominal condition $V_{DD} = +4$ V unless noted otherwise.

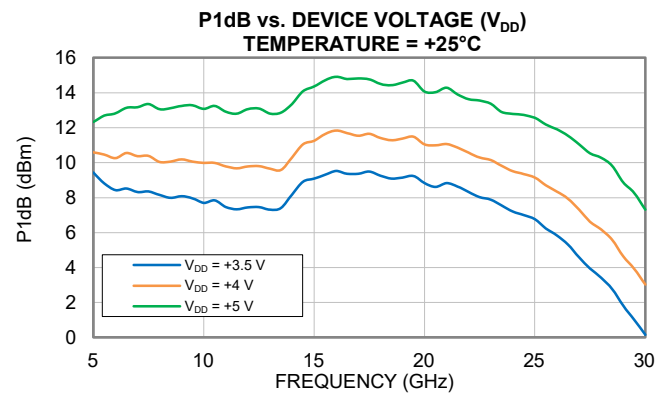
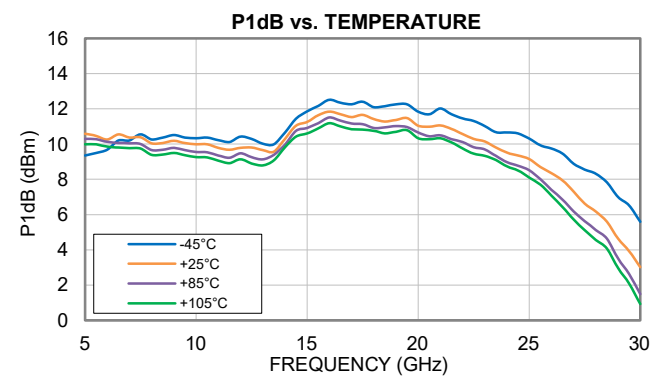
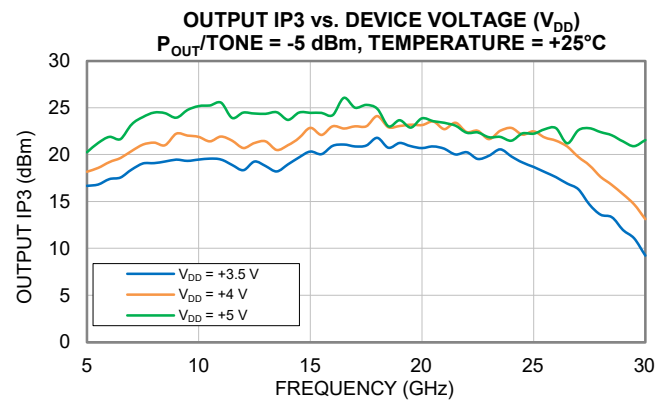
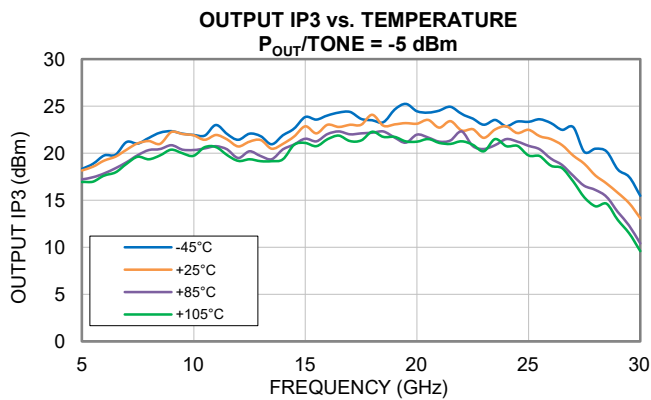
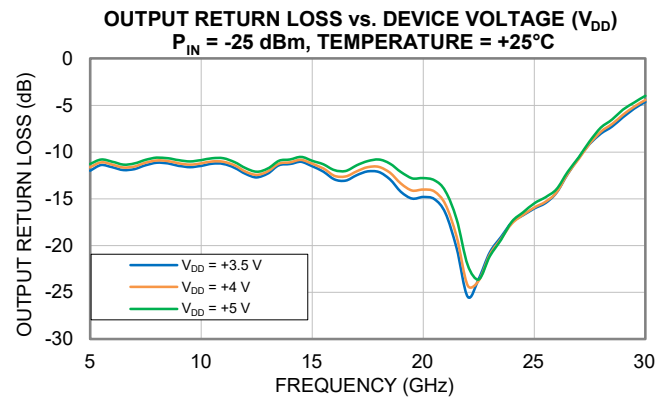
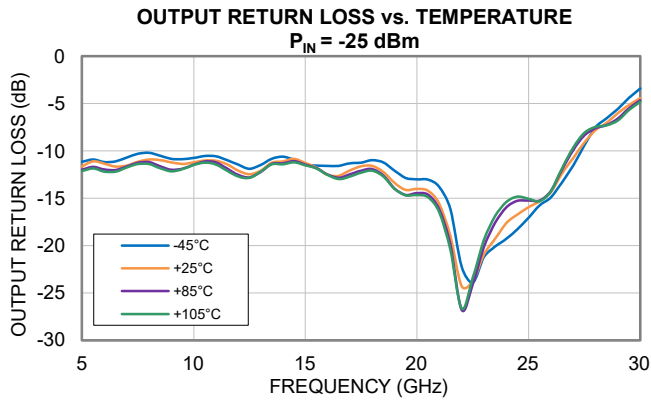

Typical Performance Curves

Note: All data taken at nominal condition $V_{DD} = +4$ V unless noted otherwise.

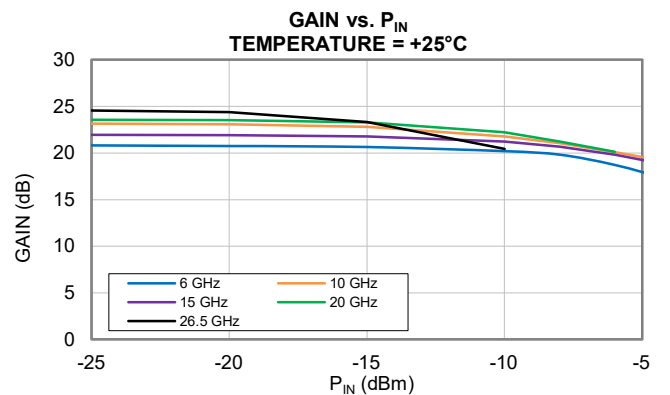
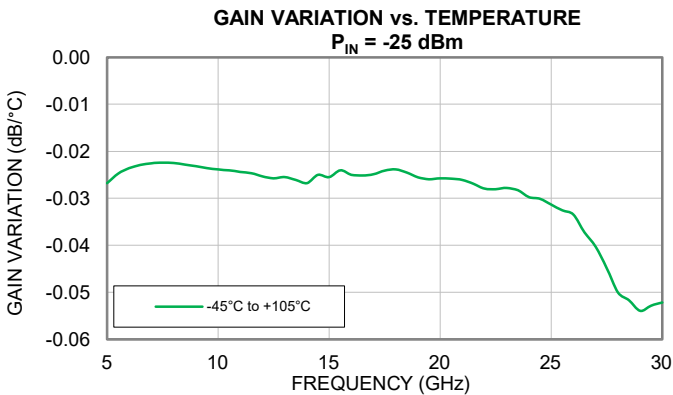
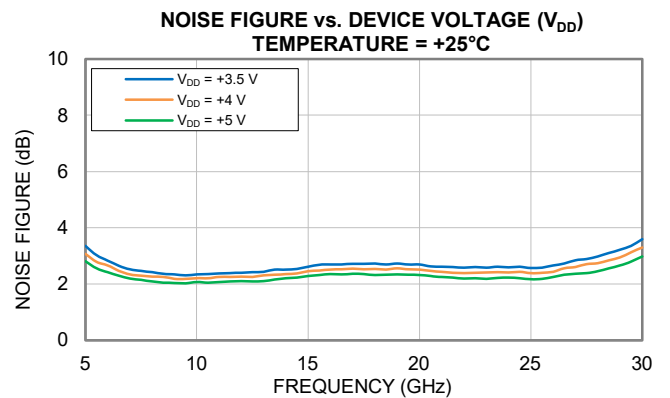
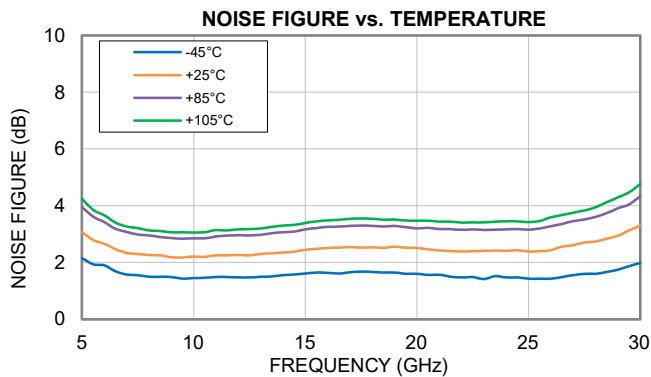
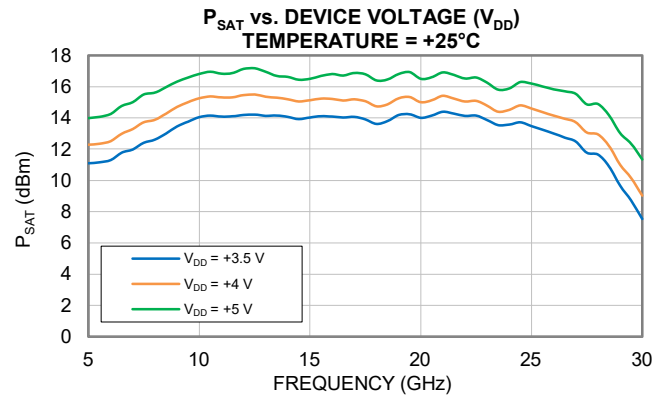
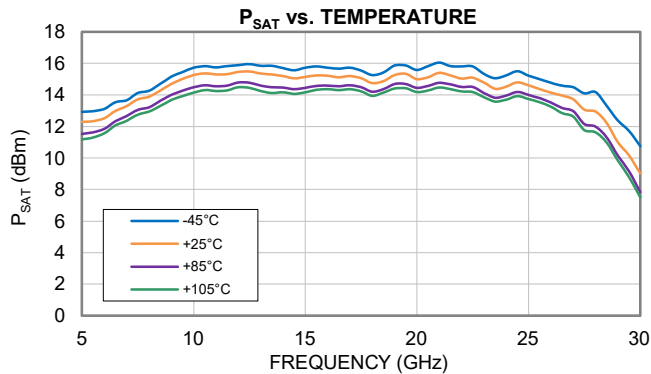

Typical Performance Curves

Note: All data taken at nominal condition $V_{DD} = +4$ V unless noted otherwise.

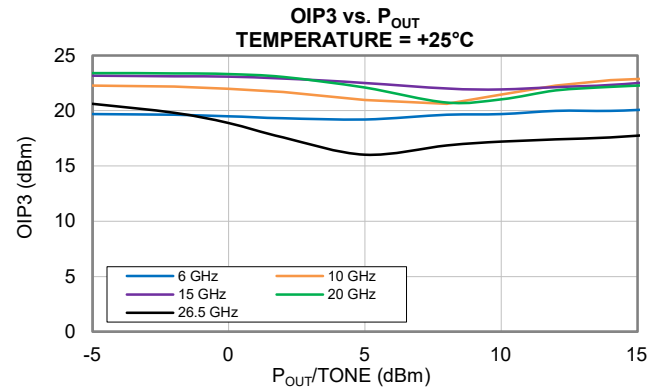
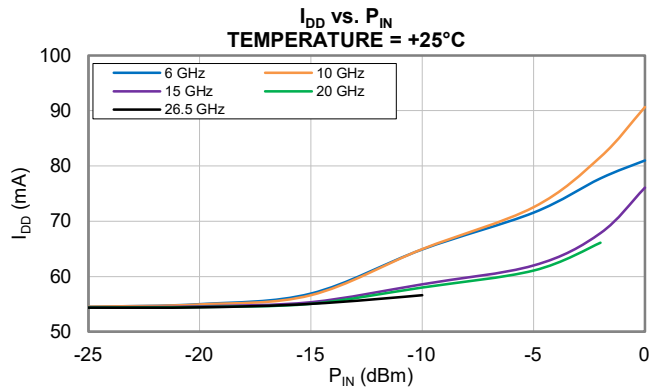

Outline Dimensions

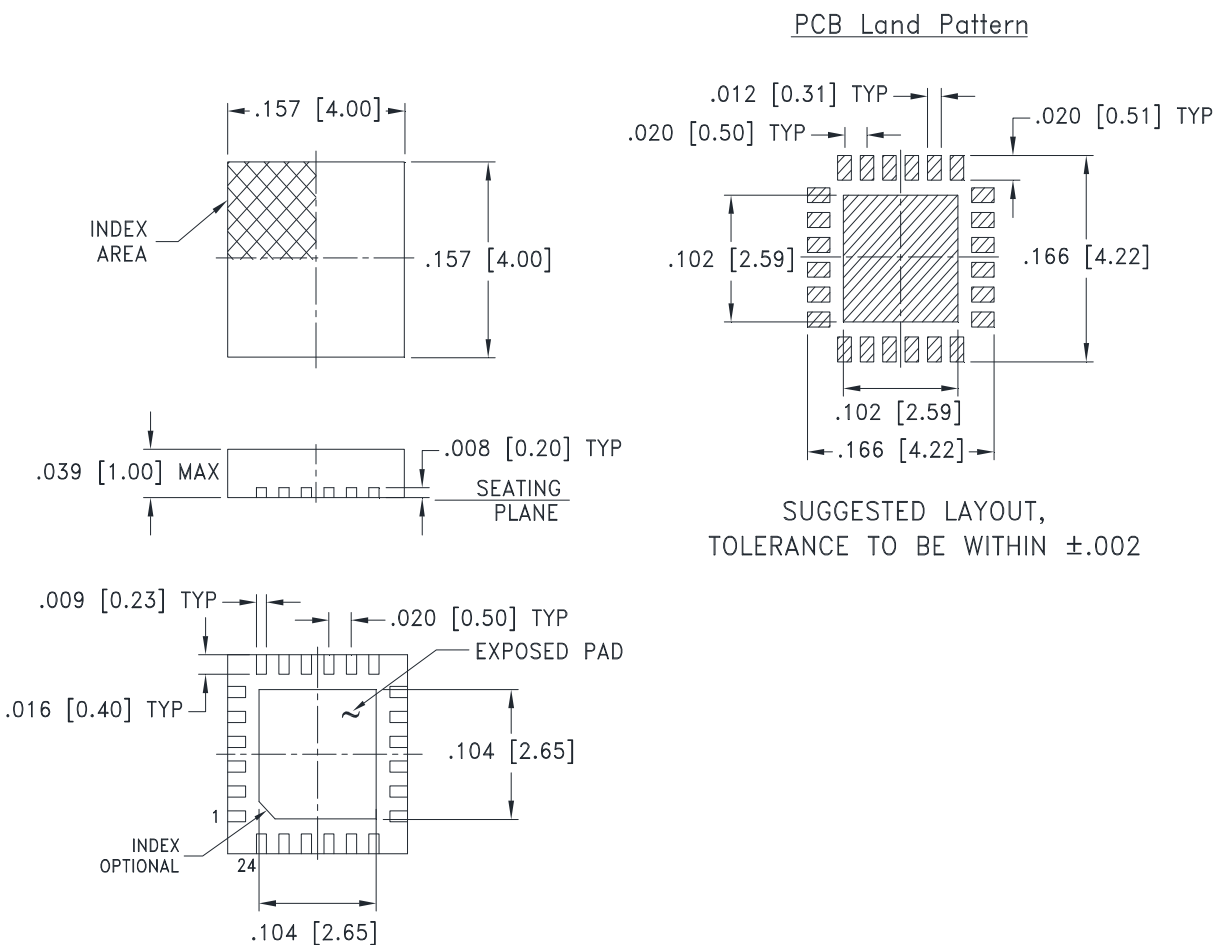

Weight: .04 Grams

Dimensions are in inches (mm). Tolerances: 2 Pl. \pm .01; 3 Pl. \pm .005

Notes:

1. Case material: Plastic.
2. Termination finish:
 - For RoHS Case Styles: Tin-Silver alloy plate over Nickel barrier or Matte-Tin. All models, (+) suffix. See model Data sheet.
 - For RoHS-5 Case Styles: Tin-Lead plate. All models, no (+) suffix.

Mini-Circuits®
ISO 9001 ISO 14001 CERTIFIED

ALL NEW
minicircuits.com

P.O. Box 350166, Brooklyn, New York 11235-0003 (718) 934-4500 Fax (718) 332-4661 For detailed performance specs & shopping online see Mini-Circuits web site



The Design Engineers Search Engine Provides ACTUAL Data Instantly From MINI-CIRCUITS At: www.minicircuits.com

RF/IF MICROWAVE COMPONENTS

DG1847 Rev.: AH (16 FEB 23) ECO-016811 File: DG1847

This document and its contents are the property of Mini-Circuits.

Tape & Reel Packaging TR-F68

DEVICE ORIENTATION IN T&R

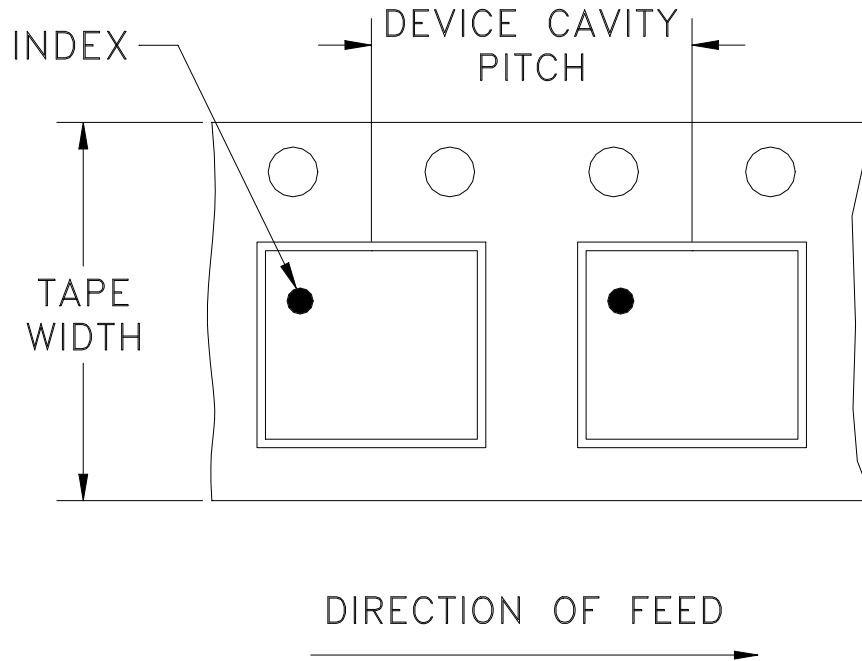

Tape Width, mm	Device Cavity Pitch, mm	Reel Size, inches	Devices per Reel see note	
12	8	7	Small quantity standard	20
				50
				100
				200
				500
		7	Standard	1000
		13	Standard	2000
				3000
				4000

Mini-Circuits carrier tape materials provide protection from ESD (Electro-Static Discharge) during handling and transportation. Tapes are static dissipative and comply with industry standards EIA-481/EIA-541.

Go to: www.minicircuits.com/pages/pdfs/tape.pdf



INTERNET <http://www.minicircuits.com>

P.O. Box 350166, Brooklyn, New York 11235-0003 (718) 934-4500 Fax (718) 332-4661

Distribution Centers NORTH AMERICA 800-654-7949 • 417-335-5935 • Fax 417-335-5945 • EUROPE 44-1252-832600 • Fax 44-1252-837010

Mini-Circuits ISO 9001 & ISO 14001 Certified

THIRD ANGLE PROJECTION

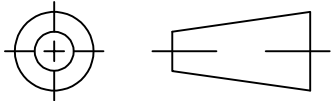

REVISIONS

REV	ECN No.	DESCRIPTION	DATE	DR	AUTH
OR	ECO-023162	NEW RELEASE	09/27/24	ITG	IL

SUGGESTED MOUNTING CONFIGURATION
FOR DG1847 CASE STYLE

COMPONENT	SIZE
C1-C3	0402
C4-C6	0603

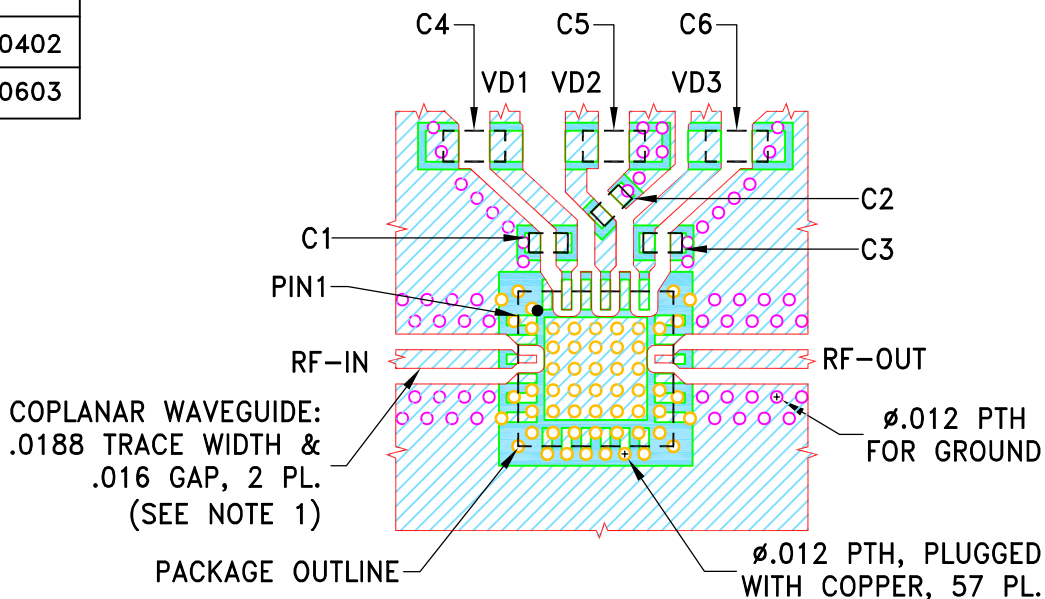

NOTES:

1. TRACE WIDTH & GAP PARAMETERS ARE SHOWN FOR ROGERS R04350B, DIELECTRIC THICKNESS: .010±.001"; COPPER: 1 OZ. EACH SIDE. FOR OTHER MATERIALS TRACE WIDTH & GAP MAY NEED TO BE MODIFIED.
2. CHIP COMPONENT FOOT PRINTS SHOWN FOR REFERENCE. FOR COMPONENT VALUES REFER TO TB-PMA4-6263LN+ AND TB-PMA4-6263LNC+.
3. BOTTOM SIDE OF THE PCB IS CONTINUOUS GROUND PLANE.

DENOTES PCB COPPER LAYOUT WITH SMOBC (SOLDER MASK OVER BARE COPPER).

DENOTES COPPER LAND PATTERN FREE OF SOLDER MASK.

UNLESS OTHERWISE SPECIFIED	INITIALS		DATE
DIMENSIONS ARE IN INCHES	DRAWN	ITG	09/26/24
TOLERANCES ON:	CHECKED	GF	09/26/24
2 PL DECIMALS ±	APPROVED	IL	09/26/24
3 PL DECIMALS ± .005			
ANGLES ±			
FRACTIONS ±			



Mini-Circuits®

13 Neptune Avenue
Brooklyn NY 11235

PL, DG1847, TB-PMA4-6263LN(C)+

Mini-Circuits®
THIS DOCUMENT AND ITS CONTENTS ARE THE PROPERTY OF MINI-CIRCUITS. EXCEPT FOR USE EXPRESSLY GRANTED, IN WRITING, TO ITS VENDORS, VENDEE AND THE UNITED STATES GOVERNMENT, MINI-CIRCUITS RESERVES ALL PROPRIETARY DESIGN, USE, MANUFACTURING AND REPRODUCTION RIGHTS THERETO. THESE CONTENTS SHALL NOT BE USED, DUPLICATED OR DISCLOSED TO ANY OUTSIDE PARTY, IN WHOLE OR IN PART, WITHOUT WRITTEN PERMISSION OF MINI-CIRCUITS.

SIZE	CODE IDENT	DRAWING NO:	REV:
A	15542	98-PL-799	OR
FILE:	98PL799	SCALE: 5:1	SHEET: 1 OF 1

Evaluation Board and Circuit

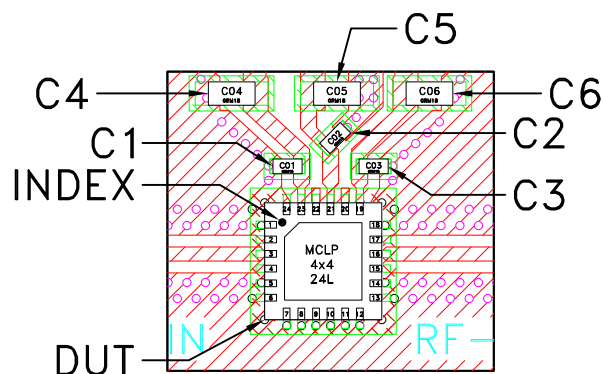
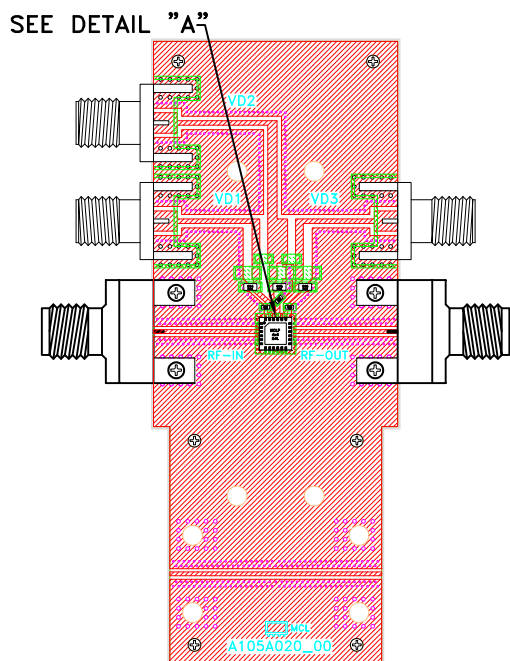

DETAIL "A"
LOCATION OF
UNITS COMPONENTS
(SCALE 3:1)

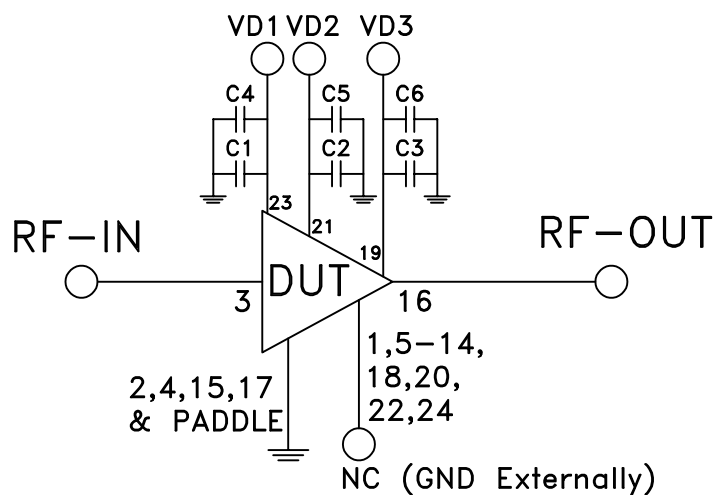

SCHEMATIC DIAGRAM

Component	Size	Value	Part Number	Manufacturer
C1,C2,C3	0402	100pF	GRM1555C1H101JA01D	Murata
C4,C5,C6	0603	0.1uF	GCM188R71E104JA57D	Murata

Notes:

1. 2.4mm Female Connectors.
2. PCB Material: Roger RO4350B or equivalent,
Dielectric constant=3.5, Thickness=0.010 inch

 Mini-Circuits®

All Mini-Circuits products are manufactured under exacting quality assurance and control standards, and are capable of meeting published specifications after being subjected to any or all of the following physical and environmental test.

Specification	Test/Inspection Condition	Reference/Spec
Operating Temperature	-40° to 85° C or -45° to 85° C or -55° to 105° C or -40° to 105° C or -40° to 95° C Ambient Environment	Individual Model Data Sheet
Storage Temperature	-55° to 100° C or -65° to 150° Ambient Environment	Individual Model Data Sheet
HTOL	1000 hours at 125°C	MIL-STD-883, Method 1005, Condition B
Thermal Shock	-55° to 100°C, 100 cycles	MIL-STD-202, Method 107, Condition A-3, except +100°C
Mechanical Shock	1.5Kg, 0.5 ms, 5 shock pulses, Y1 direction only	MIL-STD-883, Method 2002, Condition B, except Y1 direction only
Vibration (Variable Frequency)	50g peak	MIL-STD-883, Method 2007, Condition B
Autoclave	15 psig, 100% RH, 121°C, 96 hours	JESD22-A102, Condition C
HAST	130°C, 85% RH, 96 hours	JESD22-A110
Solderability	10X Magnification	J-STD-002, Para 4.2.5, Test S, 95% Coverage
Solder Reflow Heat	Sn-Pb Eutetic Process: 240°C peak Pb-Free Process: 260°C peak	J-STD-020, Table 4-1, 4-2 and 5-2; Figure 5-1
Moisture Sensitivity: Level 1	Bake at 125°C for 24 hours Soak at 85°C/85% RH for 168 hours, Reflow 3 cycles at 260°C peak	J-STD-020

All Mini-Circuits products are manufactured under exacting quality assurance and control standards, and are capable of meeting published specifications after being subjected to any or all of the following physical and environmental test.

Specification	Test/Inspection Condition	Reference/Spec
Marking Resistance to Solvents	Isopropyl alcohol + mineral spirits at 25°C; terpene defluxer at 25°C; distilled water + proylene glycol monomethyl ether + monoethanolamine at 63°C to 70°C	MIL-STD-202, Method 215