

# Low Noise, Wideband, Low Current Monolithic Amplifier Die

## PMA2-63LN-D+

50Ω 0.4 to 6 GHz

### The Big Deal

- Ultra wideband, 0.4 to 6 GHz
- Excellent noise figure, 0.5 dB at 2 GHz
- Low Current, 44mA at 5V

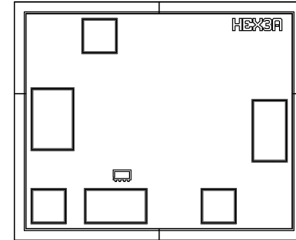

### Product Overview

The PMA2-63LN-D+ is a PHEMT based wideband, low noise MMIC amplifier die with a unique combination of high gain, high IP3 and low noise figure, making it ideal for sensitive, high-dynamic-range receiver applications. This design operates on a single 5V supply, is well matched for 50Ω.

### Key Features

Feature	Advantages
Excellent Noise Figure up to 6 GHz <ul style="list-style-type: none"><li>• 0.5 dB typ. at 2 GHz</li><li>• 0.7 dB typ. at 4 GHz</li></ul>	Enables lower system noise figure performance.
High IP3 <ul style="list-style-type: none"><li>• +31.7 dBm at 2 GHz</li><li>• +31.6 dBm at 4 GHz</li></ul>	Combination of low noise figure and high IP3 makes this MMIC amplifier ideal for use in low noise receiver front end (RFE) as it gives the user advantages of sensitivity and two-tone IM performance at both ends of the dynamic range.
Low operating voltage & current 5V & 44mA	Low voltage & current consumption is ideal for use in amplifier chain.
Unpackaged die	Enables user to integrate it directly into hybrids.

# Low Noise, Wideband, Low Current Monolithic Amplifier Die

## PMA2-63LN-D+

50Ω 0.4 to 6 GHz

### Product Features

- Wideband, 0.4 to 6 GHz
- Excellent Noise figure, 0.5 dB typ. at 2 GHz
- High Gain, 19.5 dB at 2 GHz
- High IP3, 31.7 dBm at 2 GHz.
- Low current, 44mA at 5V

### Typical Applications

- 5G
- Fixed-Satellite
- Cellular Infrastructure
- Defense

### General Description

The PMA2-63LN-D+ is a PHEMT based wideband, low noise MMIC amplifier die with a unique combination of high gain, high IP3 and low noise figure, making it ideal for sensitive, high-dynamic-range receiver applications. This design operates on a single 5V supply, is well matched for 50Ω.

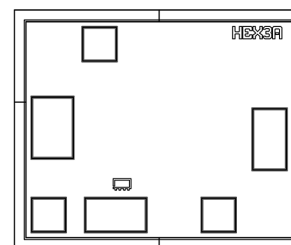

**+RoHS Compliant**

The +Suffix identifies RoHS Compliance. See our web site for RoHS Compliance methodologies and qualifications

*Ordering Information: Refer to Last Page*

### Simplified Schematic and Pad description

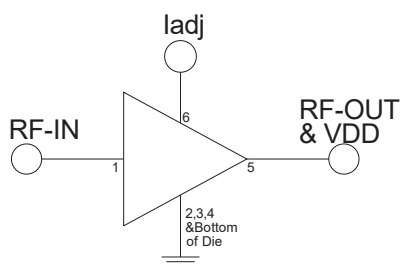

Pad#	Function
1	RF-IN
5	RF-OUT & V <sub>DD</sub>
2,3,4 & Bottom of Die	GROUND
6	Current Adjustment

### Bonding Pad Position

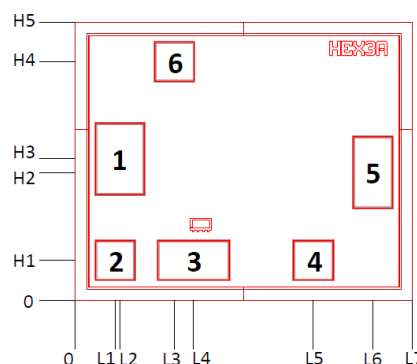

Dimensions in μm, Typical

L1	L2	L3	L4	L5	L6	L7	H1	H2	H3	H4	H5
87	97	217	258	521	651	738	87	280	309	522	609

Thickness	Die size	Pad size 1	Pad size 2, 4, & 6	Pad size 3	Pad size 5
100	738 x 609	100 x 150	80 x 80	150 x 80	80 x 150

**Electrical Specifications<sup>1</sup> at 25°C, Zo=50Ω unless noted**

Parameter	Condition (GHz)	V <sub>DD</sub> =5.0V & V <sub>adj</sub> =Open			Units
		Min.	Typ.	Max.	
Frequency Range		0.4		6	GHz
Gain	0.4		24.1		dB
	1		22.7		
	2		19.5		
	4		14.7		
	6		11.5		
Input Return Loss	0.4		7.7		dB
	1		9.5		
	2		12.0		
	4		14.2		
	6		12.0		
Output Return Loss	0.4		9.4		dB
	1		9.1		
	2		7.7		
	4		7.1		
	6		6.4		
Output Power at 1dB Compression	0.4		17.2		dBm
	1		17.1		
	2		17.7		
	4		18.4		
	6		17.9		
Output IP3	0.4		31.3		dBm
	1		30.9		
	2		31.7		
	4		31.6		
	6		32.8		
Noise Figure	0.4		0.5		dB
	1		0.5		
	2		0.5		
	4		0.7		
	6		1.0		
Device Operating Voltage (V <sub>DD</sub> )		4.75	5.0	5.25	V
Device Operating Current (I <sub>DD</sub> )		—	44	61	mA
Device Current Variation vs. Temperature <sup>2</sup>			-81		μA/°C
Device Current Variation vs. Voltage <sup>3</sup>			0.014		mA/mV
Thermal Resistance, junction-to-ground lead			65		°C/W

1. Measured on Mini-Circuits Characterization Test Board. Die is packaged in 2x2mm, 8-lead MCL package and soldered on TB-PMA2-63LNE+. See Characterization Test Circuits (Fig.2).  
 2. Device Current Variation vs. Temperature= (Current in mA at 85°C - Current in mA at -45°C)/130°C  
 3. Device Current Variation vs. Voltage = (Current in mA at 5.25V – Current in mA at 4.75V) / ((5.25V-4.75V)\*1000 mA/mV)

**Voltage Level at Current Adjustment Pad (V<sub>adj</sub>) vs. Device Current**

**Absolute Maximum Ratings<sup>4</sup>**

Parameter	Ratings
Operating Temperature	-40°C to 85°C
Junction Temperature	137°C
Total Power Dissipation	0.8W
Input Power (CW), V <sub>DD</sub> =5V	+22 dBm (5 minutes max.) +13 dBm (continuous)
Current Adjustment Voltage (V <sub>adj</sub> )	1.2V
Supply Voltage (VDD)	7V

4. Permanent damage may occur if any of these limits are exceeded.  
 Electrical maximum ratings are not intended for continuous normal operation.

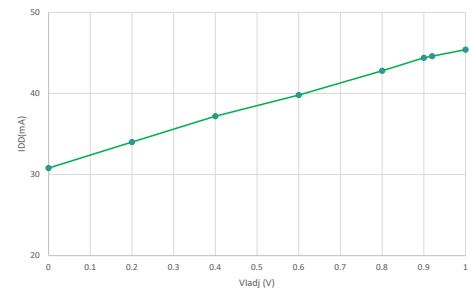

5. When I<sub>adj</sub> connection is open, V<sub>adj</sub> = 0.92V given a device with I<sub>DD</sub> = 44mA Typ. For RF performance at different V<sub>adj</sub>, please see View Data and Graph

Characterization Test & Application Circuit

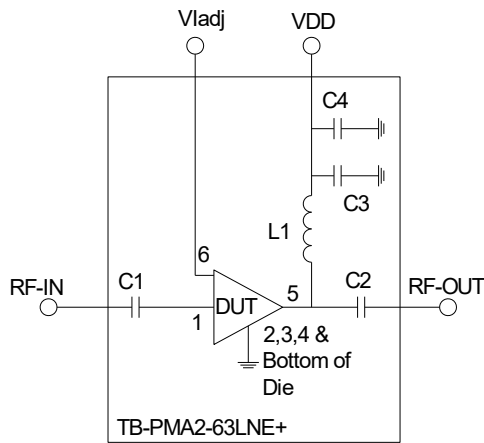

Components	Size	Value	Manufacturer	P/N
C1	0402	150pF	Murata	GRM1555C1H151JA01
C2		150pF		GRM1555C1H151JA01
C3		100pF		GRM1555C1H101JA1D
C4		1uF		GRM155R61E105KA12
L1		56nH	Coilcraft	0402CS-56NXGL

Fig 1. Application and Characterization Circuit

Note: This block diagram is used for characterization. (DUT is packaged in 2x2mm 8-lead MCLP package and soldered on Mini-Circuits Characterization test board TB-PMA2-63LNE+) Gain, Return loss, Output power at 1dB compression (P1dB), output IP3 (OIP3) and noise figure measured using Agilent’s N5242A PNA-X microwave network analyzer.

Conditions:

1. Gain and Return loss: Pin= -25dBm
2. Output IP3 (OIP3): Two tones, spaced 1 MHz apart, 0 dBm/tone at output.

## Assembly Diagram

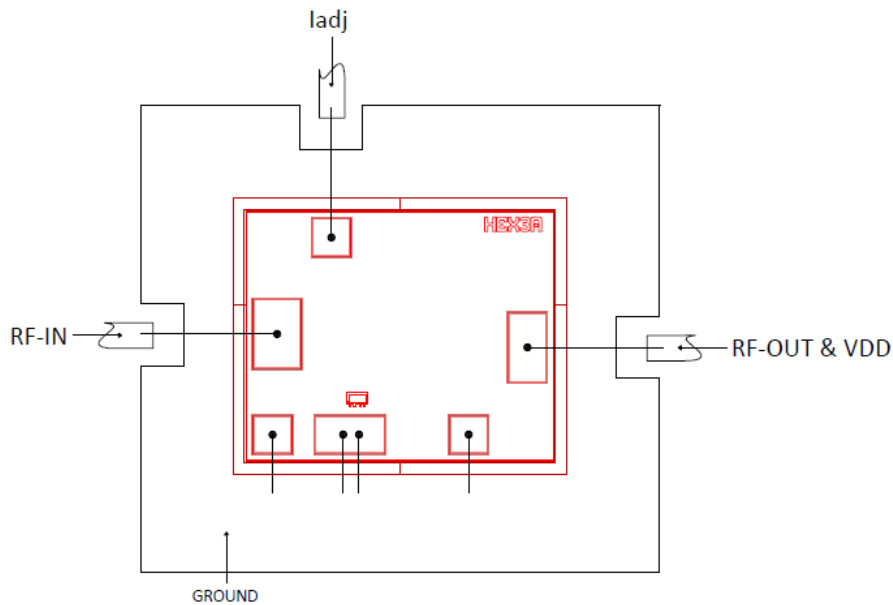

## Assembly and Handling Procedure

1. Storage  
Dice should be stored in a dry nitrogen purged desiccators or equivalent.
2.  ESD  
MMIC PHEMT amplifier dice are susceptible to electrostatic and mechanical damage. Die are supplied in antistatic protected material, which should be open in clean room conditions at an appropriately grounded anti-static workstation.
3. Die Handling and Attachment  
Devices need careful handling using correctly designed collets, it is recommended to handle the chip along the edges with a custom design collet. The die mounting surface must be clean and flat. Using conductive silver filled epoxy, recommended epoxies are Ablestik 84-1 LMISR4 or equivalents. Apply sufficient epoxy to meet required epoxy bond line thickness, epoxy fillet height and epoxy coverage around total periphery. Parts shall be cured in a nitrogen filled atmosphere per manufacturer's cure condition.
5. Wire Bonding  
Bond pad openings in the surface passivation above the bond pads are provided to allow wire bonding to the dice gold bond pads. Thermo-sonic bonding is used with minimized ultrasonic content. Bond force, time, ultrasonic power and temperature are all critical parameters. Suggested wire is pure gold, 1mil diameter. Bonds must be made from the bond pads on the die to the packaged or substrate. All bond wires should be kept as short as low as reasonable to minimize performance degradation due to undesirable series inductance.



## Typical Performance Data

### Definitions:

Input Return Loss = -S11 (dB)

Gain(Power Gain) = S21 (dB)

Reverse Isolation = -S12 (dB)

Output Return Loss = -S22 (dB)

TEST CONDITIONS: Vd = 4.75V, Vldj=Open, Id = 44mA @ Temperature = +25°C

FREQ	Gain	Isolation	Input Return Loss	Output Return Loss	Stability		IP-3 Output	1dB Comp. Output	Noise Figure
					K	Measure			
(MHz)	(dB)	(dB)	(dB)	(dB)	K	Measure	(dBm)	(dBm)	(dB)
400	24.05	28.31	8.01	9.74	1.05	0.51	31.53	17.95	0.57
600	23.74	28.21	8.83	10.09	1.07	0.53	31.60	18.03	0.52
800	23.26	28.27	9.41	9.80	1.10	0.56	31.84	18.21	0.58
1000	22.69	28.27	9.92	9.43	1.13	0.59	31.21	17.78	0.54
1200	22.08	28.26	10.42	9.06	1.16	0.61	31.39	18.23	0.55
1400	21.44	28.22	10.90	8.74	1.19	0.64	31.26	18.30	0.61
1600	20.81	28.11	11.40	8.47	1.22	0.66	31.48	18.57	0.57
1800	20.18	28.01	11.90	8.26	1.26	0.68	31.42	18.29	0.62
2000	19.55	27.83	12.48	8.10	1.29	0.69	31.53	18.37	0.55
2200	18.91	27.71	13.11	7.94	1.34	0.71	31.08	18.24	0.56
2400	18.32	27.54	13.40	7.72	1.37	0.71	31.53	18.73	0.59
2600	17.83	27.26	13.51	7.56	1.38	0.72	31.58	18.41	0.62
2800	17.34	27.05	13.64	7.49	1.40	0.73	32.08	18.57	0.69
3000	16.90	26.71	14.01	7.48	1.41	0.73	30.70	18.98	0.65
3200	16.46	26.46	14.17	7.46	1.42	0.74	31.07	18.78	0.59
3400	16.03	26.20	14.31	7.46	1.44	0.75	31.90	19.09	0.58
3600	15.60	25.94	14.37	7.46	1.45	0.76	31.08	18.86	0.59
3800	15.21	25.71	14.37	7.46	1.47	0.77	31.69	19.00	0.70
4000	14.81	25.46	14.31	7.45	1.48	0.77	31.75	19.27	0.74
4200	14.43	25.23	14.19	7.44	1.49	0.78	31.26	19.06	0.72
4400	14.07	24.99	14.02	7.39	1.50	0.78	31.86	19.21	0.74
4600	13.72	24.81	13.80	7.32	1.51	0.79	31.63	18.97	0.75
4800	13.40	24.60	13.52	7.22	1.51	0.79	31.66	18.74	0.82
5000	13.08	24.39	13.24	7.09	1.50	0.79	31.74	18.90	0.82
5200	12.76	24.19	12.97	6.97	1.50	0.79	32.20	18.84	0.85
5400	12.45	24.07	12.71	6.79	1.51	0.79	32.08	18.61	0.95
5600	12.09	23.98	12.21	6.66	1.52	0.80	32.35	18.58	0.98
5800	11.84	23.75	12.12	6.54	1.51	0.79	32.62	18.31	1.01
6000	11.53	23.60	11.91	6.34	1.50	0.79	32.00	18.62	1.00

Note: Test data of Die packaged in industry standard 2x2mm 8-Lead MCL Package

## Typical Performance Data

### Definitions:

Input Return Loss = -S11 (dB)

Gain(Power Gain) = S21 (dB)

Reverse Isolation = -S12 (dB)

Output Return Loss = -S22 (dB)

TEST CONDITIONS: Vd = 5.00V, Vldj=Open, Id = 46mA @ Temperature = +25°C

FREQ	Gain	Isolation	Input Return Loss	Output Return Loss	Stability		IP-3 Output	1dB Comp. Output	Noise Figure
					K	Measure			
(MHz)	(dB)	(dB)	(dB)	(dB)	K	Measure	(dBm)	(dBm)	(dB)
400	24.01	28.29	8.00	9.71	1.05	0.50	31.39	18.10	0.55
600	23.70	28.25	8.80	10.06	1.07	0.53	32.85	18.29	0.53
800	23.22	28.34	9.37	9.74	1.10	0.57	32.55	18.47	0.56
1000	22.65	28.29	9.88	9.37	1.13	0.59	31.99	18.03	0.57
1200	22.03	28.32	10.38	9.00	1.16	0.62	32.77	18.61	0.63
1400	21.40	28.25	10.84	8.68	1.20	0.64	31.42	18.55	0.59
1600	20.76	28.15	11.34	8.42	1.23	0.66	31.31	18.82	0.58
1800	20.13	28.07	11.85	8.21	1.27	0.68	31.68	18.53	0.56
2000	19.50	27.84	12.44	8.05	1.30	0.69	31.70	18.73	0.54
2200	18.86	27.79	13.05	7.89	1.35	0.71	30.67	18.48	0.58
2400	18.28	27.60	13.35	7.68	1.38	0.71	31.23	18.96	0.62
2600	17.78	27.28	13.52	7.53	1.39	0.72	31.10	18.51	0.64
2800	17.30	27.08	13.67	7.45	1.41	0.73	30.10	18.79	0.70
3000	16.85	26.78	14.07	7.45	1.42	0.74	31.42	19.07	0.66
3200	16.40	26.48	14.26	7.43	1.43	0.74	31.06	18.88	0.55
3400	15.98	26.23	14.43	7.43	1.44	0.75	31.74	19.19	0.61
3600	15.55	25.99	14.53	7.41	1.46	0.76	31.36	19.06	0.64
3800	15.15	25.72	14.53	7.41	1.47	0.76	31.43	19.21	0.67
4000	14.76	25.51	14.50	7.40	1.49	0.77	31.38	19.34	0.70
4200	14.38	25.27	14.38	7.38	1.50	0.78	31.78	19.14	0.71
4400	14.02	25.06	14.20	7.35	1.51	0.78	32.05	19.39	0.77
4600	13.67	24.82	13.94	7.28	1.51	0.79	31.30	19.16	0.80
4800	13.34	24.64	13.64	7.20	1.52	0.79	31.76	18.93	0.82
5000	13.02	24.44	13.30	7.09	1.52	0.79	31.77	19.08	0.89
5200	12.70	24.23	12.99	6.96	1.51	0.80	32.19	19.01	0.86
5400	12.38	24.12	12.67	6.80	1.52	0.79	31.54	18.81	0.91
5600	12.01	24.01	12.17	6.66	1.53	0.80	31.59	18.65	0.98
5800	11.76	23.80	12.02	6.55	1.52	0.80	31.92	18.51	1.00
6000	11.45	23.70	11.76	6.36	1.52	0.79	31.69	18.80	1.00

Note: Test data of Die packaged in industry standard 2x2mm 8-Lead MCL Package



## Typical Performance Data

### Definitions:

Input Return Loss = -S11 (dB)

Gain(Power Gain) = S21 (dB)

Reverse Isolation = -S12 (dB)

Output Return Loss = -S22 (dB)

TEST CONDITIONS: Vd = 5.25V, Vldj=Open, Id = 50mA @ Temperature = +25°C

FREQ	Gain	Isolation	Input Return Loss	Output Return Loss	Stability		IP-3 Output	1dB Comp. Output	Noise Figure
					K	Measure			
(MHz)	(dB)	(dB)	(dB)	(dB)	K	Measure	(dBm)	(dBm)	(dB)
400	24.22	28.44	8.25	9.84	1.05	0.50	31.49	18.35	0.57
600	23.91	28.36	9.10	10.18	1.07	0.53	32.40	18.54	0.54
800	23.42	28.38	9.70	9.86	1.10	0.55	31.96	18.83	0.62
1000	22.84	28.36	10.23	9.47	1.13	0.58	31.84	18.28	0.53
1200	22.22	28.38	10.75	9.08	1.16	0.61	32.65	18.85	0.56
1400	21.58	28.30	11.22	8.74	1.19	0.63	32.06	18.78	0.61
1600	20.94	28.26	11.72	8.47	1.23	0.66	31.56	19.05	0.56
1800	20.30	28.08	12.23	8.25	1.26	0.67	31.28	18.77	0.59
2000	19.67	27.87	12.81	8.09	1.29	0.69	31.76	18.96	0.56
2200	19.02	27.82	13.46	7.92	1.34	0.70	31.83	18.71	0.56
2400	18.43	27.59	13.75	7.70	1.37	0.71	32.16	19.19	0.77
2600	17.93	27.36	13.86	7.55	1.38	0.71	30.50	18.74	0.64
2800	17.44	27.11	13.97	7.47	1.40	0.72	30.05	19.01	0.71
3000	16.99	26.82	14.34	7.46	1.41	0.73	31.36	19.28	0.70
3200	16.55	26.51	14.50	7.45	1.42	0.74	31.06	19.08	0.59
3400	16.12	26.25	14.63	7.45	1.43	0.75	31.32	19.40	0.61
3600	15.69	25.97	14.69	7.45	1.45	0.75	31.23	19.27	0.65
3800	15.30	25.76	14.67	7.44	1.46	0.76	31.51	19.41	0.62
4000	14.90	25.49	14.59	7.44	1.47	0.77	31.56	19.54	0.72
4200	14.52	25.22	14.45	7.42	1.48	0.78	32.12	19.35	0.77
4400	14.16	25.05	14.28	7.38	1.50	0.78	31.34	19.60	0.76
4600	13.81	24.84	14.04	7.31	1.50	0.78	31.08	19.36	0.80
4800	13.49	24.62	13.76	7.22	1.50	0.79	31.04	19.02	0.83
5000	13.17	24.42	13.48	7.09	1.50	0.79	31.17	19.28	0.87
5200	12.85	24.21	13.19	6.97	1.50	0.79	31.54	19.11	0.90
5400	12.54	24.05	12.91	6.79	1.50	0.79	31.94	19.03	0.93
5600	12.18	23.98	12.39	6.66	1.51	0.79	31.49	18.86	0.98
5800	11.93	23.77	12.31	6.55	1.50	0.79	31.60	18.73	1.02
6000	11.62	23.66	12.09	6.35	1.51	0.78	31.47	19.01	1.04

Note: Test data of Die packaged in industry standard 2x2mm 8-Lead MCL Package

## Typical Performance Data

### Definitions:

Input Return Loss = -S11 (dB)

Gain(Power Gain) = S21 (dB)

Reverse Isolation = -S12 (dB)

Output Return Loss = -S22 (dB)

TEST CONDITIONS: Vd = 5.00V, Vldj = Ground, Id = 32mA @ Temperature = +25°C

FREQ	Gain	Isolation	Input Return Loss	Output Return Loss	Stability		IP-3 Output	1dB Comp. Output	Noise Figure
					K	Measure			
(MHz)	(dB)	(dB)	(dB)	(dB)	K	Measure	(dBm)	(dBm)	(dB)
400	23.37	27.92	7.22	9.11	1.05	0.51	27.64	16.08	0.58
600	23.10	27.89	7.93	9.45	1.07	0.54	27.66	16.04	0.48
800	22.65	27.91	8.46	9.22	1.09	0.57	28.33	16.37	0.55
1000	22.11	27.99	8.94	8.92	1.13	0.60	27.57	16.00	0.50
1200	21.52	28.03	9.41	8.59	1.16	0.62	28.50	16.44	0.62
1400	20.91	28.00	9.86	8.31	1.20	0.65	28.40	16.58	0.52
1600	20.30	27.94	10.33	8.07	1.23	0.67	28.99	16.88	0.55
1800	19.68	27.89	10.78	7.88	1.27	0.69	28.98	16.90	0.55
2000	19.07	27.73	11.31	7.73	1.31	0.70	29.72	17.00	0.55
2200	18.43	27.66	11.85	7.57	1.36	0.71	29.37	16.90	0.55
2400	17.85	27.59	12.12	7.38	1.40	0.72	30.18	17.61	0.59
2600	17.36	27.27	12.24	7.23	1.40	0.72	29.33	17.30	0.61
2800	16.90	27.08	12.41	7.16	1.42	0.73	29.52	17.64	0.64
3000	16.45	26.81	12.57	7.13	1.44	0.74	30.65	18.25	0.67
3200	16.01	26.62	12.72	7.12	1.46	0.75	30.19	18.19	0.59
3400	15.58	26.39	12.79	7.12	1.48	0.76	31.10	18.53	0.62
3600	15.16	26.09	12.83	7.12	1.49	0.77	30.58	18.45	0.62
3800	14.77	25.93	12.80	7.13	1.51	0.78	31.01	18.44	0.71
4000	14.38	25.72	12.78	7.14	1.53	0.78	31.34	18.89	0.71
4200	14.00	25.47	12.69	7.13	1.54	0.79	30.82	18.55	0.74
4400	13.64	25.29	12.56	7.08	1.55	0.80	31.80	18.87	0.76
4600	13.30	25.10	12.36	7.04	1.56	0.80	31.23	18.61	0.79
4800	12.98	24.85	12.18	6.94	1.56	0.80	30.74	18.36	0.85
5000	12.67	24.71	11.96	6.82	1.56	0.80	31.34	18.69	0.83
5200	12.36	24.48	11.74	6.70	1.55	0.80	30.39	18.62	0.84
5400	12.05	24.34	11.59	6.55	1.56	0.80	31.69	18.28	0.95
5600	11.74	24.15	11.40	6.39	1.55	0.80	30.57	18.46	0.87
5800	11.44	24.02	11.22	6.24	1.55	0.80	30.10	18.09	0.99
6000	11.12	23.91	11.06	6.03	1.55	0.79	30.24	18.45	1.03

Note: Test data of Die packaged in industry standard 2x2mm 8-Lead MCL Package

## Typical Performance Data

### Definitions:

Input Return Loss = -S11 (dB)

Gain(Power Gain) = S21 (dB)

Reverse Isolation = -S12 (dB)

Output Return Loss = -S22 (dB)

TEST CONDITIONS: Vd = 5.00V, Vldj = 0.2V, Id = 35mA @ Temperature = +25°C

FREQ	Gain	Isolation	Input Return Loss	Output Return Loss	Stability		IP-3 Output	1dB Comp. Output	Noise Figure
					K	Measure			
(MHz)	(dB)	(dB)	(dB)	(dB)	K	Measure	(dBm)	(dBm)	(dB)
400	23.60	28.06	7.49	9.33	1.05	0.51	28.20	16.69	0.55
600	23.32	28.00	8.23	9.67	1.07	0.54	28.91	16.77	0.51
800	22.86	28.04	8.77	9.41	1.10	0.56	29.55	17.10	0.54
1000	22.30	28.07	9.27	9.08	1.13	0.59	28.87	16.70	0.50
1200	21.71	28.10	9.75	8.74	1.16	0.62	29.88	17.16	0.61
1400	21.09	28.11	10.21	8.45	1.20	0.65	29.44	17.27	0.57
1600	20.47	28.00	10.69	8.19	1.23	0.66	30.14	17.57	0.58
1800	19.85	27.92	11.15	7.99	1.27	0.68	30.16	17.43	0.60
2000	19.23	27.85	11.69	7.83	1.31	0.70	30.04	17.53	0.57
2200	18.59	27.75	12.24	7.66	1.36	0.71	30.45	17.41	0.55
2400	18.00	27.61	12.50	7.47	1.40	0.72	30.72	18.10	0.58
2600	17.51	27.32	12.62	7.32	1.40	0.72	30.64	17.78	0.59
2800	17.04	27.06	12.79	7.25	1.41	0.73	30.99	18.11	0.70
3000	16.59	26.84	12.95	7.21	1.43	0.74	31.24	18.55	0.64
3200	16.14	26.57	13.09	7.21	1.45	0.75	31.68	18.35	0.54
3400	15.72	26.38	13.15	7.21	1.47	0.76	32.64	18.82	0.59
3600	15.30	26.10	13.20	7.22	1.48	0.77	31.73	18.59	0.61
3800	14.90	25.87	13.16	7.23	1.50	0.77	32.25	18.59	0.71
4000	14.51	25.64	13.13	7.23	1.51	0.78	32.86	19.15	0.73
4200	14.13	25.43	13.02	7.22	1.53	0.79	32.69	18.82	0.71
4400	13.77	25.22	12.88	7.18	1.54	0.79	34.55	19.00	0.78
4600	13.43	25.01	12.67	7.13	1.54	0.80	33.79	18.87	0.80
4800	13.11	24.79	12.49	7.04	1.54	0.80	33.36	18.63	0.79
5000	12.79	24.59	12.25	6.92	1.54	0.80	33.55	18.93	0.87
5200	12.49	24.41	12.03	6.80	1.54	0.80	33.75	18.75	0.89
5400	12.18	24.26	11.86	6.64	1.54	0.80	36.12	18.54	0.93
5600	11.87	24.08	11.67	6.49	1.54	0.80	34.11	18.58	0.98
5800	11.57	23.95	11.48	6.34	1.54	0.79	34.03	18.23	1.02
6000	11.25	23.83	11.32	6.13	1.54	0.79	34.47	18.56	0.96

Note: Test data of Die packaged in industry standard 2x2mm 8-Lead MCL Package

## Typical Performance Data

### Definitions:

Input Return Loss = -S11 (dB)

Gain(Power Gain) = S21 (dB)

Reverse Isolation = -S12 (dB)

Output Return Loss = -S22 (dB)

TEST CONDITIONS: Vd = 5.00V, Vldj = 0.4V, Id = 39mA @ Temperature = +25°C

FREQ	Gain	Isolation	Input Return Loss	Output Return Loss	Stability		IP-3 Output	1dB Comp. Output	Noise Figure
					K	Measure			
(MHz)	(dB)	(dB)	(dB)	(dB)	K	Measure	(dBm)	(dBm)	(dB)
400	23.80	28.15	7.71	9.49	1.05	0.51	29.75	17.23	0.57
600	23.50	28.12	8.49	9.85	1.07	0.54	30.02	17.44	0.50
800	23.03	28.15	9.05	9.57	1.10	0.56	30.78	17.62	0.55
1000	22.47	28.14	9.56	9.22	1.13	0.59	29.64	17.21	0.52
1200	21.87	28.22	10.05	8.86	1.16	0.62	30.15	17.68	0.59
1400	21.24	28.15	10.52	8.55	1.20	0.64	30.30	17.77	0.54
1600	20.61	28.06	11.00	8.28	1.23	0.66	30.49	18.06	0.61
1800	19.98	27.97	11.47	8.07	1.26	0.68	30.57	17.91	0.56
2000	19.36	27.87	12.02	7.92	1.31	0.70	31.45	18.01	0.54
2200	18.72	27.75	12.59	7.75	1.35	0.71	30.49	17.88	0.52
2400	18.12	27.61	12.85	7.54	1.39	0.72	31.24	18.54	0.55
2600	17.63	27.32	12.96	7.39	1.39	0.72	31.14	18.09	0.57
2800	17.16	27.09	13.13	7.31	1.41	0.73	31.33	18.41	0.63
3000	16.70	26.83	13.29	7.28	1.43	0.74	31.85	18.70	0.64
3200	16.26	26.54	13.43	7.28	1.44	0.75	32.49	18.63	0.57
3400	15.83	26.31	13.48	7.28	1.46	0.76	32.60	18.95	0.59
3600	15.41	26.10	13.53	7.29	1.48	0.76	32.53	18.72	0.64
3800	15.01	25.82	13.47	7.30	1.48	0.77	33.61	18.86	0.71
4000	14.62	25.59	13.45	7.31	1.50	0.78	33.16	19.27	0.68
4200	14.24	25.37	13.32	7.30	1.51	0.79	32.26	18.95	0.72
4400	13.88	25.19	13.18	7.25	1.53	0.79	33.23	19.24	0.77
4600	13.54	24.96	12.95	7.21	1.53	0.80	34.06	18.99	0.81
4800	13.22	24.70	12.76	7.12	1.53	0.80	34.59	18.75	0.84
5000	12.90	24.49	12.51	7.00	1.52	0.80	34.26	19.05	0.85
5200	12.60	24.34	12.29	6.88	1.53	0.80	35.01	18.87	0.91
5400	12.29	24.17	12.12	6.73	1.52	0.80	37.47	18.66	0.85
5600	11.98	24.02	11.92	6.57	1.53	0.80	34.78	18.69	0.91
5800	11.68	23.86	11.73	6.42	1.53	0.79	37.42	18.35	0.99
6000	11.36	23.76	11.55	6.21	1.53	0.79	35.91	18.67	1.00

Note: Test data of Die packaged in industry standard 2x2mm 8-Lead MCL Package

## Typical Performance Data

### Definitions:

Input Return Loss = -S11 (dB)

Gain(Power Gain) = S21 (dB)

Reverse Isolation = -S12 (dB)

Output Return Loss = -S22 (dB)

TEST CONDITIONS: Vd = 5.00V, Vldj = 0.6V, Id = 42mA @ Temperature = +25°C

FREQ	Gain	Isolation	Input Return Loss	Output Return Loss	Stability		IP-3 Output	1dB Comp. Output	Noise Figure
					K	Measure			
(MHz)	(dB)	(dB)	(dB)	(dB)	K	Measure	(dBm)	(dBm)	(dB)
400	23.95	28.25	7.91	9.64	1.05	0.50	30.18	17.72	0.62
600	23.65	28.18	8.72	9.99	1.07	0.53	31.44	17.80	0.49
800	23.18	28.23	9.29	9.69	1.10	0.56	31.06	18.10	0.52
1000	22.61	28.18	9.81	9.33	1.12	0.58	30.77	17.68	0.49
1200	22.00	28.24	10.32	8.96	1.16	0.62	31.27	18.15	0.56
1400	21.36	28.22	10.79	8.64	1.20	0.64	31.21	18.10	0.57
1600	20.73	28.10	11.29	8.37	1.23	0.66	31.63	18.39	0.54
1800	20.10	28.02	11.76	8.15	1.26	0.68	30.62	18.22	0.59
2000	19.47	27.85	12.31	7.99	1.30	0.69	31.87	18.32	0.51
2200	18.83	27.81	12.90	7.81	1.35	0.71	31.45	18.19	0.54
2400	18.23	27.58	13.16	7.60	1.38	0.71	32.77	18.70	0.56
2600	17.74	27.33	13.26	7.46	1.39	0.72	31.18	18.37	0.60
2800	17.27	27.09	13.44	7.38	1.41	0.73	30.77	18.68	0.67
3000	16.81	26.83	13.59	7.35	1.42	0.74	32.01	18.95	0.63
3200	16.36	26.53	13.73	7.35	1.43	0.74	31.47	18.75	0.54
3400	15.93	26.23	13.79	7.35	1.44	0.75	32.54	19.07	0.62
3600	15.51	26.04	13.83	7.35	1.46	0.76	31.90	18.97	0.66
3800	15.11	25.78	13.77	7.36	1.47	0.77	33.06	18.98	0.67
4000	14.72	25.56	13.73	7.37	1.49	0.78	32.82	19.38	0.76
4200	14.34	25.33	13.60	7.37	1.50	0.78	32.89	19.06	0.69
4400	13.98	25.12	13.46	7.33	1.52	0.79	32.30	19.34	0.77
4600	13.64	24.87	13.23	7.28	1.52	0.79	32.97	19.10	0.80
4800	13.32	24.66	13.03	7.19	1.52	0.80	33.03	18.86	0.83
5000	13.00	24.49	12.77	7.07	1.52	0.80	32.75	19.14	0.86
5200	12.70	24.27	12.54	6.95	1.51	0.80	34.63	18.97	0.90
5400	12.39	24.12	12.35	6.80	1.52	0.80	33.67	18.77	0.89
5600	12.08	23.92	12.14	6.64	1.51	0.79	34.44	18.67	0.86
5800	11.78	23.80	11.94	6.49	1.52	0.79	36.42	18.46	1.02
6000	11.46	23.67	11.76	6.28	1.52	0.78	33.84	18.77	0.98

Note: Test data of Die packaged in industry standard 2x2mm 8-Lead MCL Package

## Typical Performance Data

### Definitions:

Input Return Loss = -S11 (dB)

Gain(Power Gain) = S21 (dB)

Reverse Isolation = -S12 (dB)

Output Return Loss = -S22 (dB)

TEST CONDITIONS: Vd = 5.00V, Vldj = 0.8V, Id = 45mA @ Temperature = +25°C

FREQ	Gain	Isolation	Input Return Loss	Output Return Loss	Stability		IP-3 Output	1dB Comp. Output	Noise Figure
					K	Measure			
(MHz)	(dB)	(dB)	(dB)	(dB)	K	Measure	(dBm)	(dBm)	(dB)
400	24.09	28.39	8.10	9.76	1.05	0.51	30.32	17.92	0.58
600	23.78	28.25	8.92	10.11	1.07	0.53	31.93	18.12	0.51
800	23.30	28.29	9.51	9.81	1.10	0.56	31.96	18.42	0.53
1000	22.73	28.30	10.04	9.43	1.13	0.59	31.31	17.87	0.52
1200	22.11	28.30	10.56	9.04	1.16	0.61	32.33	18.46	0.62
1400	21.48	28.29	11.03	8.72	1.20	0.64	31.75	18.40	0.55
1600	20.84	28.15	11.53	8.44	1.23	0.66	30.95	18.79	0.56
1800	20.21	28.09	12.01	8.21	1.26	0.68	31.55	18.51	0.55
2000	19.58	27.93	12.59	8.05	1.30	0.69	31.45	18.60	0.54
2200	18.93	27.80	13.18	7.87	1.34	0.70	31.30	18.46	0.58
2400	18.33	27.59	13.44	7.66	1.37	0.71	31.32	18.96	0.55
2600	17.83	27.38	13.55	7.50	1.39	0.72	31.78	18.51	0.61
2800	17.37	27.05	13.73	7.43	1.39	0.72	31.10	18.81	0.69
3000	16.90	26.79	13.89	7.40	1.41	0.73	31.06	19.07	0.66
3200	16.46	26.52	14.04	7.40	1.42	0.74	32.08	18.99	0.54
3400	16.02	26.25	14.08	7.40	1.44	0.75	31.86	19.30	0.59
3600	15.60	26.00	14.12	7.41	1.45	0.76	31.33	19.07	0.61
3800	15.20	25.79	14.05	7.42	1.47	0.77	31.56	19.21	0.70
4000	14.81	25.51	14.02	7.43	1.48	0.77	31.63	19.48	0.69
4200	14.43	25.30	13.90	7.42	1.50	0.78	32.22	19.17	0.72
4400	14.07	25.05	13.73	7.38	1.50	0.79	32.22	19.43	0.77
4600	13.73	24.82	13.48	7.34	1.51	0.79	31.96	19.20	0.82
4800	13.41	24.60	13.28	7.25	1.51	0.79	32.28	18.97	0.81
5000	13.09	24.41	13.02	7.13	1.51	0.79	31.67	19.23	0.86
5200	12.79	24.26	12.77	7.02	1.51	0.80	32.44	19.06	0.84
5400	12.48	24.06	12.58	6.86	1.51	0.79	32.12	18.86	0.94
5600	12.17	23.92	12.37	6.71	1.51	0.79	32.35	18.88	0.89
5800	11.87	23.77	12.15	6.55	1.51	0.79	33.73	18.56	1.02
6000	11.55	23.64	11.97	6.34	1.51	0.78	32.04	18.85	1.00

Note: Test data of Die packaged in industry standard 2x2mm 8-Lead MCL Package



## Typical Performance Curves

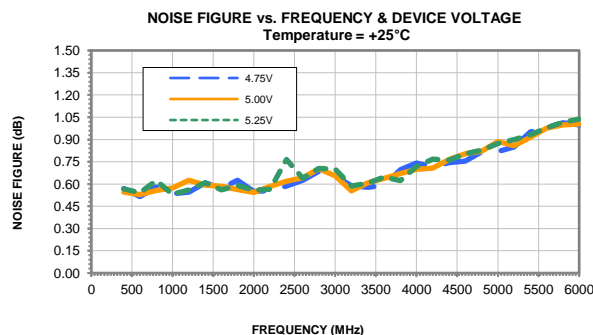
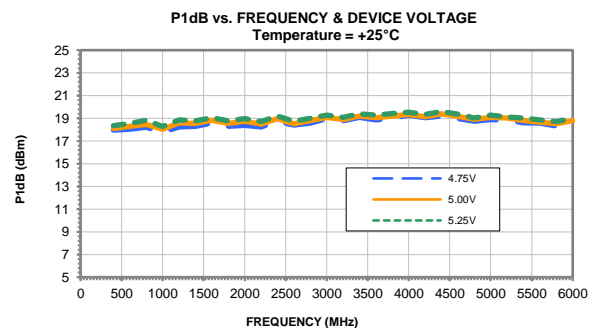
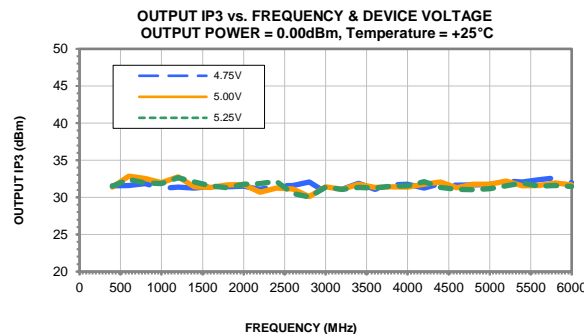
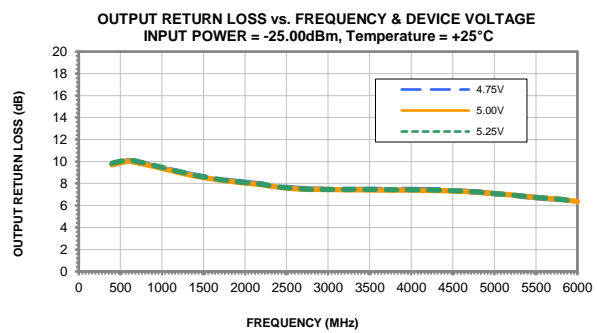
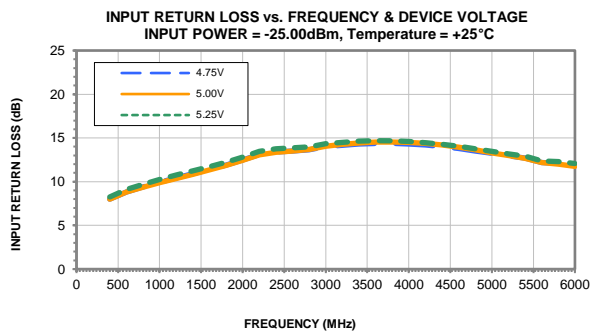
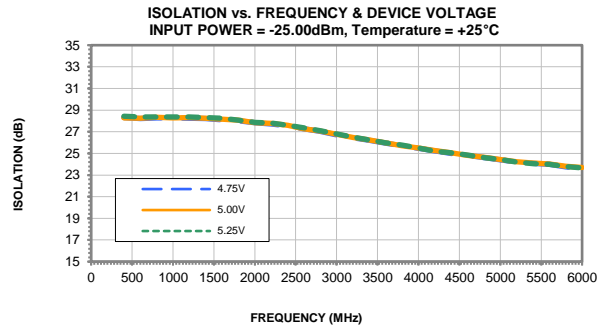
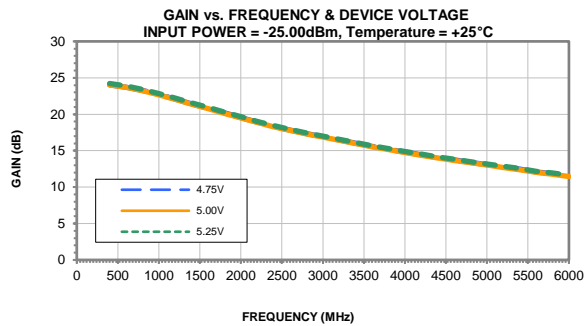

Note: Test data of Die packaged in industry standard 2x2mm 8-Lead MCL Package

## Typical Performance Curves

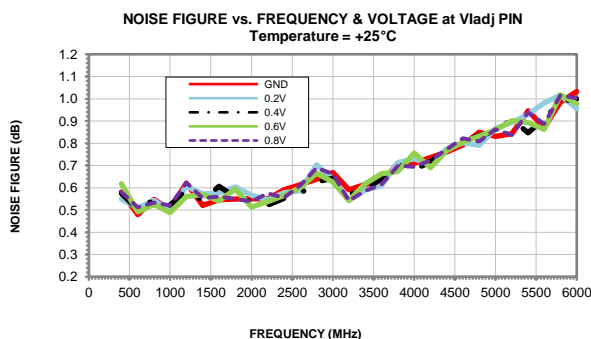
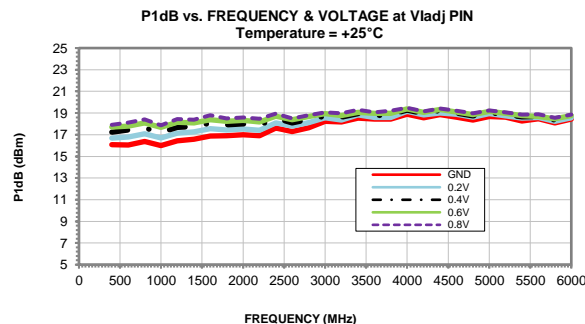
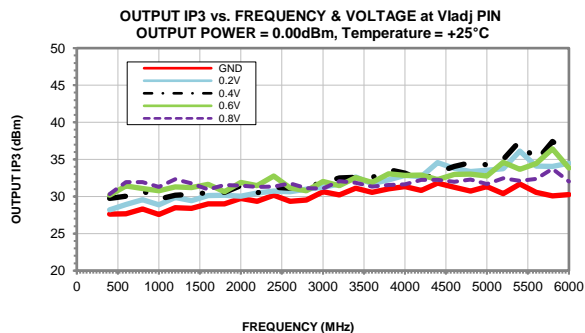
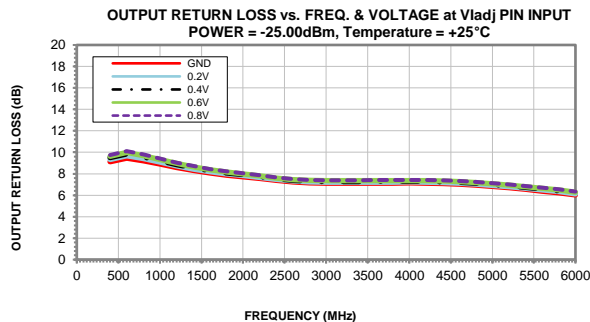
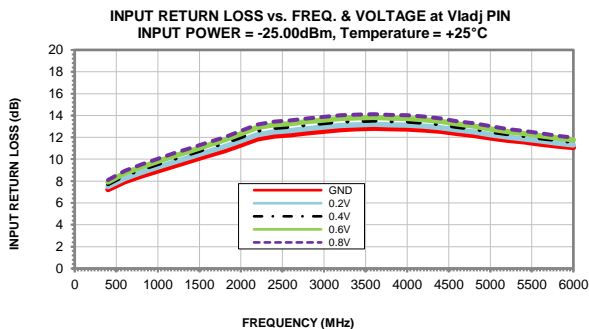
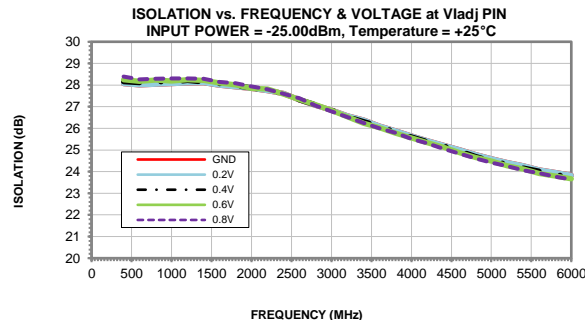
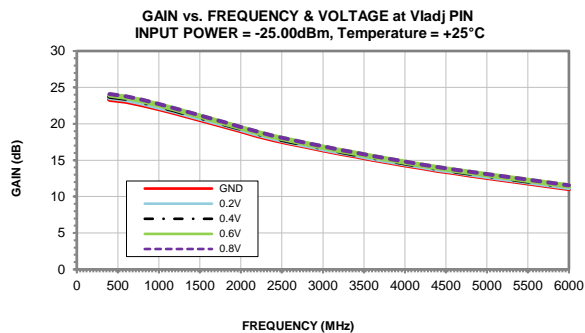

Note: Test data of Die packaged in industry standard 2x2mm 8-Lead MCL Package



All Mini-Circuits products are manufactured under exacting quality assurance and control standards, and are capable of meeting published specifications after being subjected to any or all of the following physical and environmental test.

<b>Specification</b>	<b>Test/Inspection Condition</b>	<b>Reference/Spec</b>
Operating Temperature	-40° to 85° C or -40° to 105° C or -55° to 105° C or -45° to 105° C Ambient Environment	Refer to Individual Model Data Sheet
Storage Environment (Die)	-65° to 150°C	Individual Model Data Sheet
Storage Environment(Packaging)	-40° to 70°C and 40 to 60% humidity (In Factory Shipped Package)	