



LOW NOISE, HIGH IP3

Monolithic Amplifier

PMA-545G1+

50Ω 0.4 to 2.2 GHz

THE BIG DEAL

- High Gain, 31.5 dB typ. at 0.9 GHz
- Ultra Low Noise Figure, 0.9 dB typ. at 0.9 GHz
- High IP3, 34 dBm typ. at 0.9 GHz
- Output Power, up to +22dBm typ. at 0.9 GHz
- Single Positive Supply Voltage, 5V
- Micro-miniature size - 3mm x 3mm
- Aqueous washable
- Protected by U.S. patent no. 8,803,612

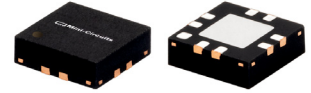

Generic photo used for illustration purposes only

CASE STYLE: DQ849

+RoHS Compliant

The +Suffix identifies RoHS Compliance. See our web site for RoHS Compliance methodologies and qualifications

LTE Performance

APPLICATIONS

- Cellular
- ISM
- GSM
- WCDMA
- LTE
- GPS

PRODUCT OVERVIEW

Mini-Circuits PMA-545G1+ is a E-PHEMT* based Low Noise MMIC Amplifier operating from 0.4 to 2.2 GHz with a unique combination of low noise and high IP3 making this amplifier ideal for sensitive receiver applications. This design operates on a single +5V supply and is internally matched to 50 Ohms.

KEY FEATURES

Feature	Advantages
High Gain 26-33 dB	Incorporating multiple stages of amplification, the PMA-545G1+ provides high gain reducing cost and PCB board space.
Ultra Low Noise: 0.9 dB NF at 0.9 GHz	Excellent Noise Figure, measured in a 50 Ohm environment – without any external matching. When combined with high gain of this design, it suppresses second stage NF contribution.
High IP3: +34 dBm IP3 at 0.9 GHz	Combining Low Noise and High IP3 makes this MMIC amplifier ideal for Low Noise Receiver Front End (RFE) giving the user advantages at both ends of the dynamic range: sensitivity & two-tone IM dynamic range
Output Power: +22 dBm at 0.9 GHz	The PMA-545G1+ maintains consistent output power capability over the full operating temperature range making it ideal to be used in remote applications such as LNB's as the L Band driver stage
Internally Matched	No external matching elements required to achieve the advertised noise and output power over the full band
MCLP Package	Low Inductance, repeatable transitions, excellent thermal pad
Max Input Power +25 dBm	Ruggedized design operates up to input powers often seen at Receiver inputs.
High Reliability	Low, small signal operating current of 160 mA nominal maintains junction temperatures typically below 130°C at 85°C ground lead temperature

*Enhancement mode Pseudomorphic High Electron Mobility Transistor.

REV. B
ECO-010881
PMA-545G1+
TH/RS/CP/AM
211201





LOW NOISE, HIGH IP3

Monolithic Amplifier

PMA-545G1+

ELECTRICAL SPECIFICATIONS⁽¹⁾ AT 25°C, VD=5V, ZO=50Ω, (REFER TO CHARACTERIZATION CIRCUIT)

Parameter	Condition (GHz)	Min.	Typ.	Max.	Units
Frequency Range		0.4		2.2	GHz
DC Voltage (Vd)		4.8	5.0	5.2	V
DC Current			158	186	mA
Noise Figure	0.4		1.2	—	dB
	0.9		0.9	—	
	1.2		1.0	1.4	
	1.6		1.0	—	
	2.2		1.2	—	
Gain	0.4	—	32.9	—	dB
	0.9	—	31.5	—	
	1.2	28.1	31.3	34.5	
	1.6	—	30.2	—	
	2.2	—	26.1	—	
Input Return Loss	0.4		9.5		dB
	0.9		11.6		
	1.2		11.9		
	1.6		14.6		
	2.2		19.9		
Output Return Loss	0.4		21.3		dB
	0.9		17.5		
	1.2		16.1		
	1.6		15.1		
	2.2		14.2		
Output IP3	0.4		31.7		dBm
	0.9		33.4		
	1.2		33.6		
	1.6		33.8		
	2.2		33.6		
Output Power @ 1 dB compression ⁽²⁾	0.4	—	20.5		dBm
	0.9	—	21.9		
	1.2	20.0	22.2		
	1.6	—	22.4		
	2.2	—	22.6		
DC Current Variation vs. Temperature ⁽³⁾			-0.156		mA/°C
DC Current Variation vs. Voltage			0.027		mA/mV
Thermal Resistance			48		°C/W

MAXIMUM RATINGS⁽⁴⁾

Parameter	Ratings
Operating Temperature ⁽⁵⁾	-40°C to 85°C
Storage Temperature	-65°C to 150°C
Channel Temperature	150°C
DC Voltage (Pad 4,5,7)	6V
Power Dissipation	1.35W
Input Power	25dBm

(1) Measured on Mini-Circuits Characterization test board TB-607-1+ . See Characterization Test Circuit (Fig. 1)
 (2) Current increases at P1dB
 (3) (Current at 85°C - Current at -45°C)/130
 (4) Permanent damage may occur if any of these limits are exceeded. These maximum ratings are not intended for continuous normal operation.
 (5) Defined with reference to ground pad temperature.

DC CURRENT HISTOGRAM

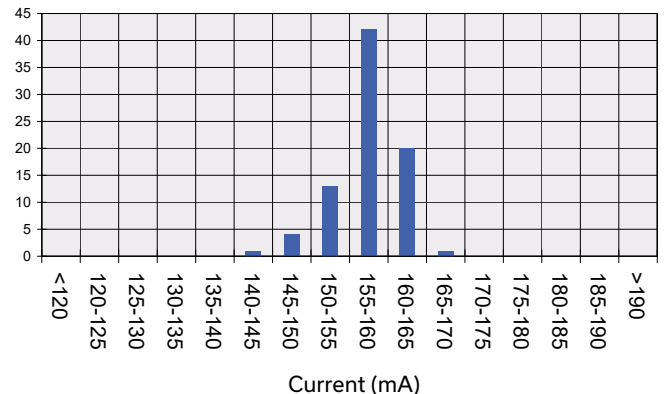



LOW NOISE, HIGH IP3

Monolithic Amplifier

PMA-545G1+

SIMPLIFIED SCHEMATIC AND PAD DESCRIPTION

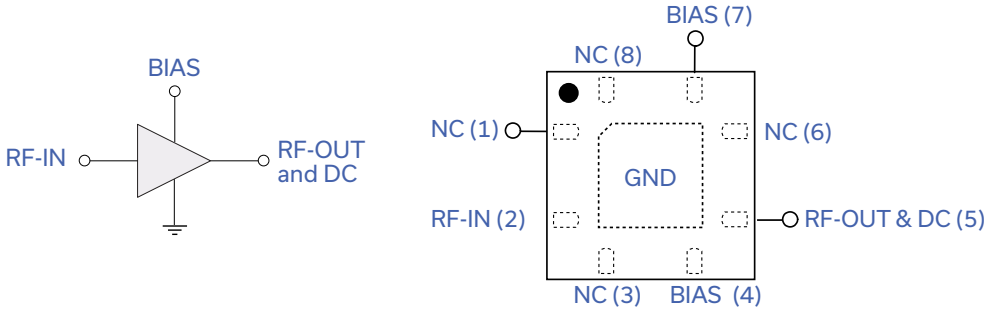

Function	Pad Number	Description (See Application Circuit, Fig. 2)
RF-IN	2	RF input pad (connected to RF-IN via C1)
RF-OUT & DC	5	RF output pad (connected to RF-OUT via blocking external cap C2, and Supply voltage Vs via RF Choke L2)
BIAS	4 & 7	Bias pad 4 connects to Vs via L1 & pad 7 connects to Vs
GND	paddle in center of bottom	Connected to ground
NOT USED	1,3,6,8	No internal connection; recommended use: per PCB Layout PL-346

CHARACTERIZATION TEST CIRCUIT AND RECOMMENDED APPLICATION CIRCUIT

(refer to evaluation board for PCB Layout and component values)

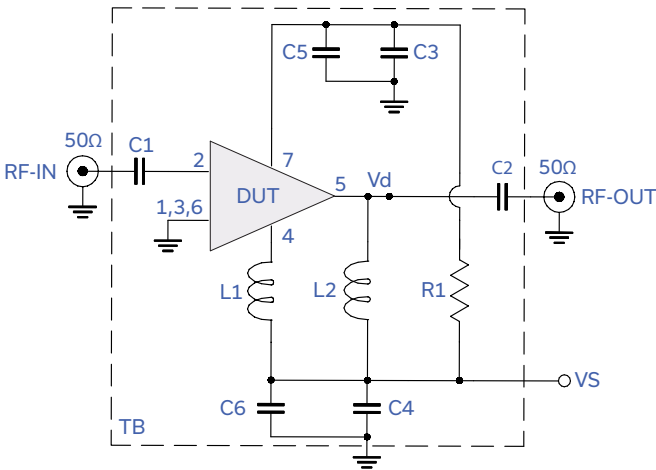

Fig 1. Block Diagram of Test Circuit used for characterization. (DUT soldered on Mini-Circuits Characterization Test Board TB-607-1) Gain, Output power at 1dB compression (P1dB), Output IP3 (OIP3), Noise Figure are measured using Agilent's N5242A PNA-X microwave network analyzer.

Conditions:

- Gain: Pin=-25 dBm
- Output IP3 (OIP3): Two tones, spaced 1 MHz apart, 0 dBm/tone at output.
- Vs adjusted for 5V at device (Vd), compensating loss of bias tee.

Component	Description
DUT	PMA-545G1+
C1, C2, C5, C6	100 pF
C3, C4	1μF
R1	0 Ω
L1	36 nH
L2	47 nH

PRODUCT MARKING

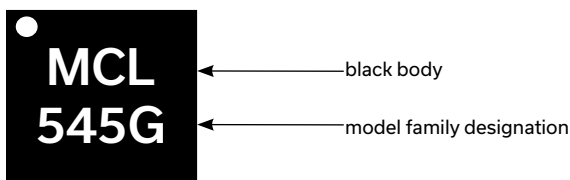

Marking may contain other features or characters for internal lot control





LOW NOISE, HIGH IP3

Monolithic Amplifier

PMA-545G1+

ADDITIONAL DETAILED TECHNICAL INFORMATION IS AVAILABLE ON OUR DASH BOARD. TO ACCESS [CLICK HERE](#)

Performance Data	Data Table
	Swept Graphs
	S-Parameter (S2P Files) Data Set (.zip file)
Case Style	Case Style: DQ849 Plastic package, exposed paddle, lead finish: tin-silver over nickel
Tape & Reel	F104
Standard quantities available on reel	7" reels with 20, 50, 100, 200, 500,1K or 2K devices
Suggested Layout for PCB Design	PL-346
Evaluation Board	TB-607-1+
Environmental Ratings	ENV08T1

ESD RATING

Human Body Model (HBM): Class 1B (500V to <1000V) in accordance with ANSI/ESD STM 5.1 - 2001

Machine Model (MM): Class M1 (passes 40V) in accordance with ANSI/ESD STM5.2-1999; passes 40V

MSL RATING

Moisture Sensitivity: MSL1 in accordance with IPC/JEDEC J-STD-020D

MSL TEST FLOW CHART

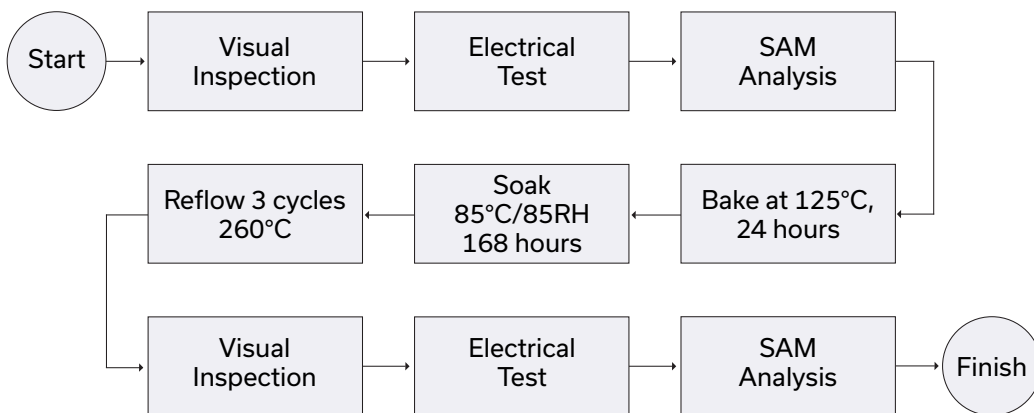

- NOTES**
- A. Performance and quality attributes and conditions not expressly stated in this specification document are intended to be excluded and do not form a part of this specification document.
 - B. Electrical specifications and performance data contained in this specification document are based on Mini-Circuit's applicable established test performance criteria and measurement instructions.
 - C. The parts covered by this specification document are subject to Mini-Circuits standard limited warranty and terms and conditions (collectively, "Standard Terms"); Purchasers of this part are entitled to the rights and benefits contained therein. For a full statement of the standard. Terms and the exclusive rights and remedies thereunder, please visit Mini-Circuits' website at www.minicircuits.com/MCLStore/terms.jsp



Typical Performance Data

NOTE: Use PDF Bookmarks to view DATA at required conditions

Definitions:

Input Return Loss = -S11 (dB)

Gain(Power Gain) = S21 (dB)

Reverse Isolation = -S12 (dB)

Output Return Loss = -S22 (dB)

TEST CONDITIONS: Vd = 5V, Id = 145.30mA @ Temperature = +25degC

FREQ	Gain	Isolation	Input Return Loss	Output Return Loss	Stability		IP-3 Output	1dB Comp. Output	Noise Figure
					K	Measure			
(MHz)	(dB)	(dB)	(dB)	(dB)	K	Measure	(dBm)	(dBm)	(dB)
200.0	24.09	59.43	1.59	15.86	8.73	1.65	26.39	13.55	5.95
300.0	30.23	56.98	6.56	17.57	8.30	1.20	31.88	19.07	1.58
350.0	30.39	51.98	12.50	13.54	5.46	1.00	33.26	20.24	1.28
400.0	32.77	51.98	10.21	22.81	4.18	1.07	32.02	20.50	1.14
450.0	32.51	61.27	20.44	22.44	13.53	1.00	33.14	21.28	1.05
500.0	32.28	66.80	20.48	20.70	26.13	1.00	33.85	21.45	1.02
550.0	32.07	69.19	16.82	19.83	34.77	1.01	33.45	21.54	0.99
600.0	31.87	64.08	14.75	19.42	19.46	1.02	34.27	21.62	0.96
650.0	31.70	63.85	13.66	19.16	19.12	1.03	34.04	21.65	0.96
700.0	31.57	68.28	12.92	19.00	32.05	1.04	33.44	21.71	0.95
750.0	31.45	69.53	12.49	18.85	37.28	1.04	33.73	21.81	0.89
800.0	31.36	61.86	12.18	18.76	15.52	1.05	33.30	21.89	0.86
850.0	31.28	65.17	12.05	18.61	22.86	1.05	33.71	21.91	0.91
900.0	31.21	60.69	11.96	18.52	13.75	1.05	33.42	21.91	0.92
950.0	31.15	61.27	11.93	18.39	14.78	1.05	33.74	22.01	1.04
1000.0	31.10	62.35	11.93	18.25	16.83	1.05	33.76	21.92	0.94
1050.0	31.05	58.72	11.98	18.10	11.15	1.05	34.32	21.96	0.97
1100.0	30.99	60.61	12.07	17.91	13.96	1.05	34.10	22.05	0.94
1150.0	30.94	59.68	12.18	17.77	12.64	1.04	34.49	21.95	0.97
1200.0	30.87	59.05	12.33	17.64	11.87	1.04	34.60	22.17	0.95
1250.0	30.79	58.28	12.49	17.56	10.97	1.04	34.70	22.08	0.97
1300.0	30.70	56.86	12.69	17.46	9.45	1.03	34.09	22.07	0.98
1350.0	30.59	56.48	12.90	17.43	9.18	1.03	34.57	22.21	0.96
1400.0	30.46	56.06	13.18	17.50	8.92	1.03	33.85	22.04	0.94
1450.0	30.31	54.78	13.48	17.60	7.87	1.03	34.64	22.26	0.97
1500.0	30.14	54.86	13.79	17.80	8.13	1.02	34.34	22.21	0.98
1600.0	29.71	53.74	14.64	18.31	7.59	1.02	34.81	22.37	1.02
1700.0	29.18	54.70	15.58	19.03	9.07	1.01	34.66	22.23	0.98
1800.0	28.57	52.00	16.72	19.59	7.20	1.01	34.74	22.41	1.05
1900.0	27.87	52.20	17.97	19.63	8.03	1.00	34.70	22.37	1.09
2000.0	27.12	51.54	19.31	18.83	8.13	1.00	34.50	22.48	1.09
2100.0	26.33	52.45	20.57	17.59	9.86	0.99	34.84	22.51	1.18
2200.0	25.51	52.70	21.81	16.03	11.09	0.98	35.21	22.60	1.18
2300.0	24.68	51.44	22.49	14.65	10.46	0.97	35.72	22.41	1.26
2400.0	23.84	51.73	22.81	13.36	11.78	0.96	35.78	22.24	1.25
2500.0	23.02	51.52	22.91	12.27	12.46	0.94	35.01	21.93	1.26
2600.0	22.19	51.98	22.58	11.30	14.21	0.93	35.33	21.73	1.36
2700.0	21.38	51.97	22.25	10.52	15.34	0.92	34.67	21.43	1.36
2800.0	20.58	52.57	21.84	9.85	17.69	0.90	35.24	21.05	1.45
2900.0	19.80	52.17	21.36	9.27	18.17	0.89	34.60	20.68	1.55
3000.0	19.04	51.98	20.90	8.71	19.04	0.87	34.79	20.32	1.49

Typical Performance Data

Definitions:

Input Return Loss = -S11 (dB)

Gain(Power Gain) = S21 (dB)

Reverse Isolation = -S12 (dB)

Output Return Loss = -S22 (dB)

TEST CONDITIONS: Vd = 4.75V, Id = 139.32mA @ Temperature = +25degC

FREQ	Gain	Isolation	Input Return Loss	Output Return Loss	Stability		IP-3 Output	1dB Comp. Output	Noise Figure
					K	Measure			
(MHz)	(dB)	(dB)	(dB)	(dB)	K	Measure	(dBm)	(dBm)	(dB)
200.0	23.99	59.12	1.58	15.80	8.41	1.65	26.19	13.57	5.91
300.0	30.11	55.24	6.54	17.07	6.86	1.20	31.87	19.60	1.59
350.0	30.29	52.12	12.56	13.30	5.60	1.00	32.77	20.59	1.25
400.0	32.65	51.86	10.16	22.83	4.18	1.07	32.65	20.71	1.15
450.0	32.41	61.09	20.55	21.36	13.39	1.00	33.85	21.28	1.06
500.0	32.20	64.82	20.95	19.82	20.99	1.00	32.73	21.28	1.05
550.0	31.99	69.53	17.04	19.06	36.47	1.01	33.40	21.33	1.03
600.0	31.80	65.38	14.92	18.70	22.77	1.02	33.40	21.36	0.99
650.0	31.64	69.72	13.77	18.46	37.83	1.03	34.31	21.36	0.98
700.0	31.51	62.15	13.01	18.36	15.92	1.03	33.94	21.42	0.94
750.0	31.40	63.49	12.55	18.27	18.70	1.04	33.93	21.47	0.87
800.0	31.31	63.94	12.26	18.21	19.81	1.04	34.03	21.56	0.82
850.0	31.23	62.84	12.13	18.14	17.57	1.05	33.78	21.61	0.90
900.0	31.17	61.06	12.02	18.09	14.41	1.05	33.67	21.60	0.92
950.0	31.11	61.85	11.98	17.99	15.86	1.05	33.83	21.71	1.07
1000.0	31.06	59.40	12.00	17.88	12.03	1.05	33.83	21.65	0.93
1050.0	31.01	60.37	12.04	17.80	13.52	1.05	34.01	21.70	0.94
1100.0	30.96	63.71	12.12	17.65	20.00	1.04	33.84	21.77	0.97
1150.0	30.91	58.53	12.24	17.57	11.12	1.04	33.80	21.69	0.97
1200.0	30.84	56.37	12.36	17.41	8.74	1.04	34.49	21.89	0.97
1250.0	30.77	56.94	12.54	17.36	9.43	1.04	33.93	21.82	0.97
1300.0	30.68	55.33	12.73	17.25	7.95	1.03	34.32	21.81	0.98
1350.0	30.57	55.11	12.95	17.25	7.86	1.03	34.00	21.95	0.97
1400.0	30.44	54.97	13.23	17.32	7.88	1.03	33.70	21.80	1.00
1450.0	30.29	54.73	13.53	17.38	7.83	1.02	34.08	21.99	0.96
1500.0	30.12	54.53	13.86	17.55	7.84	1.02	34.23	21.95	1.01
1600.0	29.70	54.10	14.71	17.97	7.91	1.02	34.75	22.11	0.99
1700.0	29.19	53.65	15.68	18.55	8.04	1.01	35.24	22.00	0.98
1800.0	28.58	51.63	16.85	18.97	6.89	1.00	34.52	22.17	1.04
1900.0	27.89	52.03	18.11	18.88	7.84	1.00	34.47	22.12	1.09
2000.0	27.14	51.66	19.52	18.12	8.20	0.99	35.12	22.21	1.08
2100.0	26.36	52.17	20.83	16.99	9.50	0.99	35.03	22.22	1.16
2200.0	25.54	52.29	22.13	15.57	10.52	0.98	35.08	22.29	1.20
2300.0	24.71	51.65	22.88	14.25	10.66	0.97	35.65	22.13	1.28
2400.0	23.87	51.46	23.28	13.06	11.34	0.95	35.24	21.96	1.25
2500.0	23.05	51.62	23.28	12.00	12.51	0.94	34.66	21.67	1.22
2600.0	22.23	51.49	22.88	11.08	13.33	0.93	35.20	21.46	1.34
2700.0	21.42	52.08	22.39	10.32	15.39	0.91	34.98	21.13	1.36
2800.0	20.62	51.67	21.98	9.65	15.82	0.90	35.24	20.79	1.46
2900.0	19.84	51.87	21.42	9.09	17.40	0.88	34.69	20.43	1.51
3000.0	19.07	52.08	20.91	8.55	19.07	0.87	34.77	20.07	1.52

Typical Performance Data

Definitions:

Input Return Loss = -S11 (dB)

Gain(Power Gain) = S21 (dB)

Reverse Isolation = -S12 (dB)

Output Return Loss = -S22 (dB)

TEST CONDITIONS: Vd = 5.25V, Id = 152.28mA @ Temperature = +25degC

FREQ	Gain	Isolation	Input Return Loss	Output Return Loss	Stability		IP-3 Output	1dB Comp. Output	Noise Figure
					K	Measure			
(MHz)	(dB)	(dB)	(dB)	(dB)	K	Measure	(dBm)	(dBm)	(dB)
200.0	24.18	60.96	1.62	15.86	10.40	1.65	26.45	13.49	6.00
300.0	30.33	56.01	6.61	17.85	7.37	1.20	32.16	18.33	1.61
350.0	30.48	50.34	12.47	13.70	4.51	1.00	31.93	19.67	1.27
400.0	32.86	53.36	10.24	22.77	4.83	1.08	32.61	20.05	1.16
450.0	32.60	63.24	20.29	23.18	16.80	1.00	32.63	21.09	1.10
500.0	32.36	64.39	20.25	21.24	19.64	1.00	32.57	21.45	1.04
550.0	32.14	62.89	16.71	20.31	16.70	1.01	33.69	21.69	1.04
600.0	31.94	66.07	14.71	19.82	24.31	1.02	33.00	21.86	1.03
650.0	31.77	66.59	13.61	19.55	26.05	1.03	33.98	21.93	0.99
700.0	31.63	64.74	12.89	19.36	21.20	1.04	33.05	22.03	0.97
750.0	31.51	62.47	12.45	19.16	16.45	1.04	34.08	22.14	0.91
800.0	31.41	64.36	12.16	19.06	20.59	1.05	33.55	22.23	0.85
850.0	31.33	64.41	12.04	18.88	20.87	1.05	33.51	22.27	0.95
900.0	31.25	64.59	11.95	18.76	21.45	1.05	33.68	22.23	0.92
950.0	31.20	66.01	11.92	18.63	25.41	1.05	34.21	22.33	1.12
1000.0	31.14	58.88	11.94	18.43	11.25	1.05	34.23	22.21	0.95
1050.0	31.08	60.50	11.99	18.26	13.65	1.05	34.04	22.27	0.97
1100.0	31.03	60.65	12.07	18.06	13.98	1.05	34.17	22.35	0.96
1150.0	30.97	58.68	12.18	17.90	11.24	1.04	34.18	22.23	0.99
1200.0	30.90	58.10	12.32	17.77	10.61	1.04	34.72	22.48	0.99
1250.0	30.82	56.21	12.49	17.67	8.64	1.04	34.53	22.37	1.00
1300.0	30.72	56.57	12.68	17.58	9.12	1.03	33.96	22.35	0.99
1350.0	30.61	56.93	12.89	17.58	9.66	1.03	34.11	22.50	0.97
1400.0	30.48	55.06	13.15	17.63	7.94	1.03	34.45	22.32	0.98
1450.0	30.32	55.60	13.46	17.73	8.63	1.03	34.10	22.55	0.99
1500.0	30.15	54.41	13.79	17.96	7.71	1.02	34.04	22.47	1.00
1600.0	29.71	53.93	14.61	18.50	7.75	1.02	34.60	22.64	1.01
1700.0	29.19	54.02	15.55	19.30	8.40	1.01	34.38	22.47	1.01
1800.0	28.57	53.45	16.65	20.01	8.52	1.01	34.50	22.66	1.06
1900.0	27.86	52.77	17.87	20.09	8.58	1.00	34.27	22.63	1.13
2000.0	27.11	51.52	19.20	19.25	8.13	1.00	35.02	22.75	1.13
2100.0	26.31	51.48	20.37	17.94	8.85	0.99	35.44	22.80	1.19
2200.0	25.49	51.00	21.45	16.33	9.16	0.98	35.39	22.90	1.22
2300.0	24.66	51.80	22.22	14.86	10.95	0.97	35.68	22.72	1.28
2400.0	23.81	52.94	22.55	13.54	13.59	0.96	35.36	22.54	1.28
2500.0	22.99	52.50	22.69	12.42	14.02	0.95	35.13	22.21	1.26
2600.0	22.17	52.02	22.47	11.43	14.35	0.93	34.90	22.00	1.40
2700.0	21.35	52.22	22.12	10.64	15.88	0.92	34.98	21.72	1.40
2800.0	20.56	52.63	21.78	9.97	17.93	0.91	34.66	21.32	1.50
2900.0	19.78	52.13	21.37	9.36	18.20	0.89	34.23	20.95	1.58
3000.0	19.01	52.80	20.98	8.80	21.05	0.87	34.34	20.58	1.54

Typical Performance Data

Definitions:

Input Return Loss = -S11 (dB)

Gain(Power Gain) = S21 (dB)

Reverse Isolation = -S12 (dB)

Output Return Loss = -S22 (dB)

TEST CONDITIONS: Vd = 5V, Id = 157.91mA @ Temperature = -45degC

FREQ	Gain	Isolation	Input Return Loss	Output Return Loss	Stability		IP-3 Output	1dB Comp. Output	Noise Figure
					K	Measure			
(MHz)	(dB)	(dB)	(dB)	(dB)	K	Measure	(dBm)	(dBm)	(dB)
200.0	24.24	59.71	1.92	15.46	10.28	1.60	29.01	16.14	5.82
300.0	30.04	58.92	6.86	16.64	10.75	1.18	36.53	21.65	1.55
350.0	30.50	50.10	13.51	13.03	4.38	0.98	36.93	22.50	1.17
400.0	32.87	53.28	9.02	21.20	4.62	1.10	36.70	22.55	1.04
450.0	32.84	59.62	18.31	19.34	10.66	1.00	36.83	23.00	0.93
500.0	32.81	62.68	38.03	18.15	15.36	0.98	37.20	22.99	0.85
550.0	32.72	66.79	24.86	17.52	24.74	0.99	37.52	23.01	0.87
600.0	32.61	66.47	19.64	17.21	23.93	0.99	36.35	23.02	0.81
650.0	32.50	68.48	17.37	17.05	30.27	1.00	36.98	23.00	0.80
700.0	32.41	65.52	15.99	17.02	21.61	1.00	36.28	23.04	0.75
750.0	32.32	62.56	15.11	16.98	15.44	1.01	37.59	23.09	0.67
800.0	32.23	64.08	14.60	17.09	18.51	1.01	36.73	23.16	0.66
850.0	32.17	64.59	14.32	17.07	19.73	1.02	38.98	23.19	0.73
900.0	32.11	64.36	14.11	17.12	19.29	1.02	36.84	23.18	0.73
950.0	32.06	59.11	14.03	17.08	10.61	1.02	37.18	23.28	0.88
1000.0	32.01	61.29	14.01	17.08	13.69	1.02	36.68	23.21	0.72
1050.0	31.97	60.83	14.06	17.06	13.05	1.02	37.12	23.23	0.75
1100.0	31.93	59.51	14.18	17.01	11.29	1.02	37.75	23.30	0.71
1150.0	31.88	58.20	14.25	16.92	9.77	1.02	37.13	23.23	0.76
1200.0	31.82	57.88	14.34	16.77	9.47	1.01	36.68	23.39	0.76
1250.0	31.74	58.34	14.39	16.64	10.07	1.01	36.54	23.32	0.74
1300.0	31.66	56.85	14.47	16.47	8.58	1.01	37.64	23.33	0.75
1350.0	31.55	56.45	14.60	16.44	8.30	1.01	37.13	23.43	0.73
1400.0	31.43	57.49	14.75	16.45	9.49	1.01	38.01	23.31	0.75
1450.0	31.29	55.37	14.98	16.51	7.58	1.01	38.55	23.45	0.74
1500.0	31.14	55.52	15.25	16.68	7.88	1.01	37.44	23.42	0.73
1600.0	30.75	54.32	16.04	16.87	7.22	1.00	37.07	23.55	0.74
1700.0	30.26	53.27	17.16	17.20	6.82	1.00	37.87	23.47	0.72
1800.0	29.67	52.85	18.58	17.51	7.00	0.99	38.24	23.57	0.78
1900.0	29.00	52.03	20.25	17.38	6.91	0.99	36.94	23.61	0.78
2000.0	28.27	51.94	22.34	16.89	7.45	0.98	38.58	23.69	0.83
2100.0	27.50	51.27	24.52	16.05	7.53	0.98	38.25	23.69	0.89
2200.0	26.69	51.76	26.70	14.95	8.67	0.97	38.47	23.75	0.87
2300.0	25.86	51.89	28.25	13.83	9.60	0.96	39.98	23.68	0.94
2400.0	25.03	51.76	28.24	12.66	10.27	0.95	39.70	23.62	0.91
2500.0	24.19	51.03	27.15	11.53	10.22	0.93	38.01	23.40	0.91
2600.0	23.35	51.79	25.29	10.56	12.03	0.91	38.62	23.32	1.01
2700.0	22.53	51.37	23.70	9.79	12.35	0.90	38.52	23.11	1.05
2800.0	21.73	51.98	22.67	9.13	14.22	0.88	38.20	22.88	1.11
2900.0	20.94	51.64	21.97	8.57	14.70	0.86	38.56	22.62	1.18
3000.0	20.14	50.97	21.30	8.07	14.60	0.85	38.67	22.34	1.18

Typical Performance Data

Definitions:

Input Return Loss = -S11 (dB)

Gain(Power Gain) = S21 (dB)

Reverse Isolation = -S12 (dB)

Output Return Loss = -S22 (dB)

TEST CONDITIONS: Vd = 4.75V, Id = 146.13mA @ Temperature = -45degC

FREQ	Gain	Isolation	Input Return Loss	Output Return Loss	Stability		IP-3 Output	1dB Comp. Output	Noise Figure
					K	Measure			
(MHz)	(dB)	(dB)	(dB)	(dB)	K	Measure	(dBm)	(dBm)	(dB)
200.0	23.93	61.04	1.92	15.49	12.39	1.60	28.33	15.64	5.81
300.0	29.73	55.78	6.85	16.71	7.75	1.18	35.62	21.70	1.59
350.0	30.21	51.28	13.58	13.10	5.17	0.99	36.36	22.40	1.17
400.0	32.56	50.55	9.02	21.29	3.53	1.10	36.31	22.32	1.03
450.0	32.57	60.11	18.22	19.27	11.64	1.00	36.10	22.63	0.95
500.0	32.56	63.49	36.98	18.07	17.34	0.98	36.26	22.50	0.88
550.0	32.48	63.96	25.04	17.50	18.36	0.98	36.29	22.48	0.82
600.0	32.39	67.48	19.74	17.15	27.57	0.99	36.19	22.46	0.82
650.0	32.28	65.47	17.35	17.02	21.95	1.00	36.81	22.41	0.81
700.0	32.20	64.37	15.93	16.94	19.37	1.01	37.83	22.45	0.75
750.0	32.12	64.64	15.08	16.94	20.06	1.01	37.10	22.49	0.68
800.0	32.04	64.99	14.56	17.04	20.98	1.02	36.71	22.56	0.65
850.0	31.98	63.11	14.27	17.02	16.97	1.02	37.12	22.61	0.75
900.0	31.93	63.49	14.09	17.03	17.82	1.02	36.94	22.61	0.70
950.0	31.88	60.78	13.99	17.02	13.11	1.02	36.44	22.72	0.81
1000.0	31.84	62.89	13.96	17.01	16.76	1.02	37.07	22.66	0.71
1050.0	31.81	58.70	14.03	16.98	10.41	1.02	36.59	22.67	0.73
1100.0	31.77	58.65	14.13	16.93	10.41	1.02	36.98	22.75	0.73
1150.0	31.72	58.41	14.22	16.83	10.17	1.02	36.55	22.69	0.76
1200.0	31.67	57.46	14.30	16.68	9.18	1.01	36.91	22.84	0.76
1250.0	31.60	58.38	14.37	16.54	10.29	1.01	36.63	22.79	0.74
1300.0	31.51	56.03	14.44	16.37	7.92	1.01	36.38	22.79	0.74
1350.0	31.41	57.28	14.57	16.34	9.27	1.01	38.57	22.90	0.74
1400.0	31.30	55.87	14.73	16.33	8.00	1.01	36.44	22.77	0.72
1450.0	31.16	54.46	14.97	16.41	6.92	1.01	37.56	22.93	0.72
1500.0	31.01	55.36	15.22	16.54	7.83	1.01	37.69	22.90	0.76
1600.0	30.63	54.18	16.00	16.74	7.19	1.00	37.83	23.03	0.76
1700.0	30.15	53.51	17.13	17.04	7.10	1.00	37.47	22.95	0.71
1800.0	29.57	52.87	18.53	17.34	7.10	0.99	37.98	23.07	0.78
1900.0	28.91	52.93	20.21	17.19	7.73	0.99	36.88	23.11	0.81
2000.0	28.19	50.71	22.29	16.78	6.53	0.98	37.70	23.17	0.81
2100.0	27.42	51.62	24.37	15.95	7.90	0.98	38.88	23.16	0.88
2200.0	26.61	51.58	26.37	14.88	8.57	0.97	38.26	23.21	0.88
2300.0	25.79	50.44	27.76	13.78	8.19	0.96	39.13	23.15	0.95
2400.0	24.96	51.93	27.63	12.61	10.55	0.95	37.62	23.07	0.88
2500.0	24.12	52.11	26.53	11.50	11.66	0.93	37.85	22.83	0.89
2600.0	23.28	52.03	24.87	10.52	12.45	0.91	38.67	22.76	1.01
2700.0	22.46	52.40	23.32	9.76	14.00	0.90	38.72	22.49	0.98
2800.0	21.66	51.81	22.41	9.11	14.05	0.88	38.75	22.29	1.08
2900.0	20.87	52.03	21.74	8.54	15.47	0.86	37.64	22.04	1.17
3000.0	20.08	51.39	21.10	8.05	15.41	0.85	38.03	21.74	1.16

Typical Performance Data

Definitions:

Input Return Loss = -S11 (dB)

Gain(Power Gain) = S21 (dB)

Reverse Isolation = -S12 (dB)

Output Return Loss = -S22 (dB)

TEST CONDITIONS: Vd = 5.25V, Id = 165.64mA @ Temperature = -45degC

FREQ	Gain	Isolation	Input Return Loss	Output Return Loss	Stability		IP-3 Output	1dB Comp. Output	Noise Figure
					K	Measure			
(MHz)	(dB)	(dB)	(dB)	(dB)	K	Measure	(dBm)	(dBm)	(dB)
200.0	24.36	59.84	1.95	15.47	10.37	1.59	29.71	16.44	5.83
300.0	30.14	56.10	6.88	16.67	7.69	1.18	36.35	21.52	1.54
350.0	30.60	51.78	13.50	13.05	5.23	0.99	37.09	22.52	1.16
400.0	32.97	51.63	9.00	21.17	3.80	1.10	36.30	22.68	1.04
450.0	32.95	59.88	18.17	19.38	10.84	1.00	36.85	23.25	0.94
500.0	32.92	66.41	36.64	18.12	23.28	0.98	36.38	23.35	0.90
550.0	32.82	80.17	25.23	17.55	114.10	0.99	39.39	23.44	0.83
600.0	32.71	66.96	19.89	17.22	25.03	0.99	38.52	23.49	0.81
650.0	32.60	64.59	17.52	17.10	19.14	1.00	36.81	23.49	0.81
700.0	32.50	62.01	16.09	17.00	14.28	1.00	37.36	23.54	0.76
750.0	32.40	65.19	15.26	17.03	20.72	1.01	37.53	23.58	0.71
800.0	32.32	61.05	14.71	17.10	12.94	1.01	36.38	23.66	0.65
850.0	32.25	63.31	14.43	17.07	16.88	1.02	36.73	23.67	0.74
900.0	32.19	60.34	14.25	17.13	12.06	1.02	36.68	23.64	0.71
950.0	32.14	61.71	14.12	17.12	14.18	1.02	37.26	23.74	0.92
1000.0	32.09	59.40	14.11	17.11	10.93	1.02	36.45	23.66	0.73
1050.0	32.04	60.61	14.15	17.11	12.64	1.02	37.57	23.67	0.76
1100.0	32.00	60.18	14.28	17.05	12.11	1.02	37.44	23.74	0.74
1150.0	31.95	59.38	14.36	16.96	11.10	1.02	37.37	23.67	0.76
1200.0	31.88	57.25	14.42	16.79	8.76	1.01	37.82	23.82	0.76
1250.0	31.81	57.68	14.48	16.69	9.28	1.01	37.02	23.75	0.75
1300.0	31.72	56.93	14.54	16.50	8.60	1.01	37.88	23.76	0.76
1350.0	31.61	56.34	14.68	16.47	8.14	1.01	37.12	23.85	0.74
1400.0	31.49	55.53	14.84	16.49	7.54	1.01	37.35	23.73	0.74
1450.0	31.35	54.43	15.05	16.57	6.77	1.01	37.29	23.87	0.73
1500.0	31.19	55.85	15.32	16.71	8.13	1.01	37.75	23.84	0.78
1600.0	30.80	54.38	16.10	16.92	7.24	1.00	38.20	23.95	0.77
1700.0	30.30	52.22	17.27	17.25	6.03	1.00	37.72	23.87	0.73
1800.0	29.71	53.18	18.61	17.59	7.25	0.99	36.94	23.96	0.79
1900.0	29.03	52.42	20.37	17.44	7.21	0.99	38.33	24.02	0.83
2000.0	28.30	51.45	22.46	16.94	7.02	0.98	38.22	24.10	0.85
2100.0	27.52	51.78	24.60	16.10	7.96	0.98	38.38	24.10	0.88
2200.0	26.71	51.75	26.88	14.99	8.65	0.97	38.62	24.17	0.87
2300.0	25.88	51.85	28.44	13.85	9.54	0.96	39.39	24.11	0.96
2400.0	25.04	51.29	28.52	12.68	9.72	0.95	38.39	24.05	0.94
2500.0	24.20	51.75	27.36	11.54	11.09	0.93	39.33	23.84	0.90
2600.0	23.36	52.60	25.44	10.57	13.19	0.91	38.72	23.78	1.04
2700.0	22.54	51.79	23.81	9.81	12.94	0.90	38.98	23.59	1.05
2800.0	21.75	51.59	22.77	9.15	13.59	0.88	38.58	23.35	1.12
2900.0	20.95	51.99	22.08	8.58	15.29	0.87	37.93	23.10	1.18
3000.0	20.16	51.34	21.35	8.08	15.21	0.85	38.43	22.82	1.16

Typical Performance Data

Definitions:

Input Return Loss = -S11 (dB)

Gain(Power Gain) = S21 (dB)

Reverse Isolation = -S12 (dB)

Output Return Loss = -S22 (dB)

TEST CONDITIONS: Vd = 5V, Id = 135.95mA @ Temperature = +85degC

FREQ	Gain	Isolation	Input Return Loss	Output Return Loss	Stability		IP-3 Output	1dB Comp. Output	Noise Figure
					K	Measure			
(MHz)	(dB)	(dB)	(dB)	(dB)	K	Measure	(dBm)	(dBm)	(dB)
200.0	23.70	60.44	1.47	16.01	9.59	1.67	24.04	11.71	6.46
300.0	30.04	57.08	6.31	18.74	8.48	1.22	29.60	16.99	1.78
350.0	29.98	50.39	11.32	14.20	4.74	1.02	30.01	18.18	1.54
400.0	32.35	52.23	10.57	23.76	4.54	1.07	29.95	18.55	1.37
450.0	31.98	59.74	17.88	26.80	12.01	1.01	30.66	19.55	1.28
500.0	31.66	63.42	16.27	23.87	18.81	1.02	31.13	19.84	1.30
550.0	31.39	68.98	14.07	22.57	36.20	1.03	30.85	19.99	1.29
600.0	31.15	72.90	12.70	21.77	57.43	1.05	31.22	20.14	1.25
650.0	30.96	61.43	11.89	21.26	15.47	1.06	31.39	20.22	1.22
700.0	30.82	64.38	11.37	20.83	21.89	1.06	31.08	20.30	1.18
750.0	30.69	62.82	11.04	20.44	18.43	1.07	31.76	20.38	1.18
800.0	30.59	64.38	10.87	20.23	22.23	1.07	31.40	20.52	1.09
850.0	30.52	62.58	10.78	19.86	18.17	1.07	31.37	20.47	1.19
900.0	30.45	61.97	10.76	19.61	17.06	1.07	31.52	20.39	1.20
950.0	30.40	62.18	10.79	19.29	17.59	1.07	31.45	20.51	1.38
1000.0	30.35	61.64	10.86	18.99	16.63	1.07	31.69	20.38	1.19
1050.0	30.30	59.88	10.94	18.73	13.67	1.07	31.53	20.46	1.21
1100.0	30.25	58.75	11.06	18.43	12.09	1.06	31.83	20.56	1.22
1150.0	30.20	59.35	11.20	18.22	13.06	1.06	31.59	20.42	1.24
1200.0	30.13	58.04	11.39	18.02	11.35	1.05	32.15	20.76	1.24
1250.0	30.06	56.87	11.60	17.93	10.05	1.05	31.85	20.57	1.23
1300.0	29.96	55.97	11.83	17.80	9.19	1.05	31.68	20.57	1.24
1350.0	29.85	57.99	12.12	17.84	11.80	1.04	32.10	20.75	1.25
1400.0	29.72	55.40	12.39	17.91	8.93	1.04	31.77	20.56	1.24
1450.0	29.56	54.99	12.74	18.05	8.73	1.03	32.43	20.85	1.29
1500.0	29.38	53.86	13.10	18.33	7.87	1.03	32.04	20.73	1.27
1600.0	28.95	54.18	13.89	18.94	8.66	1.03	32.48	20.95	1.27
1700.0	28.41	52.10	14.80	19.92	7.34	1.02	32.58	20.75	1.29
1800.0	27.78	51.70	15.77	20.95	7.61	1.02	32.78	20.99	1.35
1900.0	27.08	52.86	16.77	21.24	9.47	1.01	32.35	20.88	1.38
2000.0	26.32	51.63	17.80	20.49	8.99	1.01	32.75	21.05	1.42
2100.0	25.54	51.62	18.64	18.95	9.82	1.00	32.86	21.22	1.50
2200.0	24.72	51.66	19.42	17.29	10.79	0.99	33.10	21.42	1.49
2300.0	23.89	52.15	19.87	15.72	12.47	0.98	33.13	21.11	1.61
2400.0	23.06	51.26	20.13	14.32	12.25	0.97	32.88	20.90	1.58
2500.0	22.24	52.41	20.33	13.13	15.20	0.96	32.53	20.54	1.59
2600.0	21.43	52.14	20.34	12.08	15.95	0.95	32.56	20.30	1.74
2700.0	20.63	50.98	20.16	11.24	15.08	0.93	32.49	20.09	1.77
2800.0	19.85	52.47	19.97	10.49	19.26	0.92	32.27	19.60	1.86
2900.0	19.07	52.17	19.78	9.87	20.04	0.91	31.91	19.17	1.94
3000.0	18.32	51.71	19.57	9.30	20.38	0.89	31.88	18.75	1.95

Typical Performance Data

Definitions:

Input Return Loss = -S11 (dB)

Gain(Power Gain) = S21 (dB)

Reverse Isolation = -S12 (dB)

Output Return Loss = -S22 (dB)

TEST CONDITIONS: Vd = 4.75V, Id = 129.88mA @ Temperature = +85degC

FREQ	Gain	Isolation	Input Return Loss	Output Return Loss	Stability		IP-3 Output	1dB Comp. Output	Noise Figure
					K	Measure			
(MHz)	(dB)	(dB)	(dB)	(dB)	K	Measure	(dBm)	(dBm)	(dB)
200.0	23.62	59.67	1.41	16.01	8.58	1.68	23.90	11.70	6.39
300.0	29.95	56.47	6.25	18.23	7.93	1.22	30.30	17.70	1.73
350.0	29.91	50.44	11.32	13.95	4.80	1.02	30.60	18.83	1.46
400.0	32.26	51.62	10.52	24.15	4.28	1.07	30.04	19.05	1.35
450.0	31.89	62.06	18.05	25.33	15.83	1.01	30.92	19.84	1.30
500.0	31.58	65.95	16.44	22.87	25.43	1.02	31.07	19.94	1.27
550.0	31.31	70.67	14.15	21.72	44.37	1.03	30.95	19.93	1.24
600.0	31.08	67.72	12.81	21.11	31.91	1.04	31.41	20.02	1.20
650.0	30.90	65.91	11.98	20.67	26.12	1.05	30.91	20.04	1.21
700.0	30.76	63.39	11.41	20.33	19.66	1.06	31.45	20.08	1.21
750.0	30.64	65.91	11.08	20.03	26.46	1.07	30.97	20.18	1.12
800.0	30.54	64.00	10.88	19.86	21.39	1.07	31.25	20.30	1.09
850.0	30.47	61.99	10.81	19.55	17.06	1.07	31.47	20.23	1.14
900.0	30.41	61.17	10.77	19.32	15.63	1.07	31.30	20.17	0.63
950.0	30.36	60.35	10.79	19.07	14.29	1.07	31.14	20.29	1.41
1000.0	30.31	60.43	10.87	18.81	14.53	1.07	31.45	20.16	1.17
1050.0	30.27	60.97	10.95	18.60	15.55	1.07	31.54	20.24	1.20
1100.0	30.22	60.95	11.08	18.34	15.63	1.06	31.78	20.34	1.21
1150.0	30.17	57.31	11.22	18.14	10.37	1.06	31.60	20.20	1.21
1200.0	30.11	57.96	11.41	17.94	11.28	1.05	31.95	20.53	1.24
1250.0	30.03	58.97	11.61	17.84	12.82	1.05	31.82	20.37	1.21
1300.0	29.94	58.08	11.84	17.75	11.73	1.05	31.68	20.38	1.22
1350.0	29.83	55.41	12.12	17.74	8.79	1.04	31.84	20.55	1.26
1400.0	29.70	54.91	12.42	17.84	8.47	1.04	31.89	20.37	1.24
1450.0	29.54	54.76	12.76	17.93	8.52	1.03	32.03	20.64	1.24
1500.0	29.37	53.84	13.12	18.16	7.86	1.03	32.16	20.55	1.26
1600.0	28.94	53.88	13.94	18.75	8.38	1.02	32.52	20.76	1.29
1700.0	28.41	52.02	14.86	19.61	7.28	1.02	32.31	20.57	1.26
1800.0	27.78	52.25	15.88	20.40	8.09	1.01	32.44	20.80	1.32
1900.0	27.09	52.44	16.95	20.59	9.00	1.01	32.29	20.69	1.38
2000.0	26.34	51.48	17.98	19.80	8.82	1.00	32.60	20.84	1.41
2100.0	25.56	51.17	18.94	18.44	9.29	1.00	32.80	20.99	1.49
2200.0	24.75	51.12	19.75	16.85	10.10	0.99	33.13	21.19	1.50
2300.0	23.92	51.46	20.23	15.36	11.46	0.98	33.15	20.90	1.56
2400.0	23.10	50.74	20.47	14.04	11.48	0.97	32.86	20.71	1.57
2500.0	22.28	52.19	20.67	12.88	14.73	0.96	32.58	20.35	1.58
2600.0	21.46	51.72	20.66	11.85	15.09	0.94	32.94	20.14	1.71
2700.0	20.67	52.17	20.42	11.03	17.16	0.93	32.69	19.88	1.72
2800.0	19.88	52.75	20.18	10.31	19.75	0.92	32.22	19.42	1.83
2900.0	19.11	52.31	19.95	9.70	20.20	0.90	31.97	18.98	1.89
3000.0	18.35	52.19	19.69	9.15	21.35	0.89	31.87	18.57	1.92

Typical Performance Data

Definitions:

Input Return Loss = -S11 (dB)

Gain(Power Gain) = S21 (dB)

Reverse Isolation = -S12 (dB)

Output Return Loss = -S22 (dB)

TEST CONDITIONS: Vd =5V, Id = 141.96mA @ Temperature = +85degC

FREQ	Gain	Isolation	Input Return Loss	Output Return Loss	Stability		IP-3 Output	1dB Comp. Output	Noise Figure
					K	Measure			
(MHz)	(dB)	(dB)	(dB)	(dB)	K	Measure	(dBm)	(dBm)	(dB)
200.0	23.75	59.70	1.53	15.99	9.09	1.66	23.81	11.57	6.60
300.0	30.08	55.98	6.39	19.24	7.50	1.22	28.16	16.15	1.83
350.0	30.02	51.61	11.26	14.46	5.42	1.03	29.22	17.48	1.55
400.0	32.39	53.19	10.61	23.20	5.04	1.07	29.40	17.87	1.41
450.0	32.03	62.07	17.65	28.33	15.59	1.01	30.17	19.05	1.33
500.0	31.71	69.15	16.10	24.71	36.21	1.02	30.83	19.57	1.30
550.0	31.44	68.55	13.98	23.24	34.27	1.04	30.95	19.84	1.31
600.0	31.20	62.22	12.66	22.31	16.72	1.05	31.08	20.13	1.26
650.0	31.01	63.75	11.87	21.75	20.12	1.06	31.19	20.30	1.27
700.0	30.86	70.44	11.36	21.21	43.79	1.07	31.33	20.42	1.21
750.0	30.73	65.42	11.04	20.78	24.78	1.07	31.46	20.55	1.19
800.0	30.63	61.99	10.85	20.45	16.81	1.07	31.59	20.68	1.13
850.0	30.55	61.55	10.77	20.07	16.09	1.07	31.16	20.64	1.22
900.0	30.48	63.08	10.76	19.75	19.31	1.07	31.38	20.57	1.20
950.0	30.43	59.07	10.79	19.37	12.26	1.07	31.60	20.72	1.40
1000.0	30.38	62.41	10.86	19.10	18.12	1.07	31.61	20.58	1.20
1050.0	30.33	60.57	10.94	18.81	14.75	1.07	31.66	20.65	1.24
1100.0	30.27	63.01	11.08	18.48	19.70	1.06	31.72	20.74	1.24
1150.0	30.22	58.67	11.20	18.26	12.04	1.06	31.72	20.62	1.25
1200.0	30.15	58.10	11.39	18.05	11.40	1.05	32.32	20.94	1.29
1250.0	30.08	56.77	11.59	17.95	9.91	1.05	31.97	20.77	1.25
1300.0	29.98	60.10	11.83	17.89	14.74	1.05	31.70	20.76	1.27
1350.0	29.86	55.63	12.11	17.89	8.99	1.04	31.88	20.93	1.27
1400.0	29.73	55.40	12.39	17.99	8.93	1.04	31.83	20.73	1.26
1450.0	29.57	55.89	12.72	18.13	9.67	1.04	32.40	21.02	1.28
1500.0	29.39	53.87	13.07	18.42	7.88	1.03	32.16	20.90	1.29
1600.0	28.95	54.46	13.85	19.13	8.95	1.03	32.42	21.10	1.34
1700.0	28.41	53.04	14.73	20.26	8.18	1.02	32.46	20.90	1.30
1800.0	27.77	52.45	15.70	21.47	8.30	1.02	32.56	21.14	1.40
1900.0	27.07	51.70	16.68	21.97	8.31	1.01	32.49	21.00	1.42
2000.0	26.31	52.17	17.63	21.09	9.59	1.01	32.55	21.17	1.45
2100.0	25.52	52.15	18.47	19.55	10.47	1.00	32.80	21.34	1.54
2200.0	24.70	51.67	19.17	17.69	10.85	0.99	33.23	21.59	1.54
2300.0	23.87	51.32	19.61	16.06	11.37	0.99	32.86	21.27	1.62
2400.0	23.04	51.46	19.85	14.60	12.59	0.98	32.89	21.09	1.60
2500.0	22.22	51.07	20.11	13.36	13.09	0.96	32.35	20.70	1.61
2600.0	21.40	53.27	20.12	12.28	18.26	0.95	32.50	20.49	1.75
2700.0	20.60	51.00	19.99	11.42	15.20	0.94	32.38	20.26	1.80
2800.0	19.83	51.69	19.83	10.66	17.73	0.92	32.05	19.76	1.93
2900.0	19.05	52.14	19.70	10.01	20.08	0.91	31.88	19.32	1.95
3000.0	18.29	51.92	19.51	9.43	21.02	0.90	31.58	18.94	2.00

Typical Performance Curves

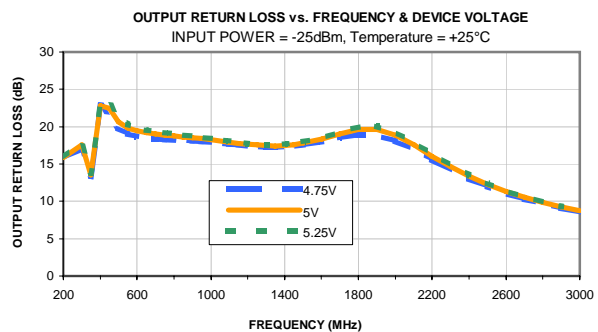
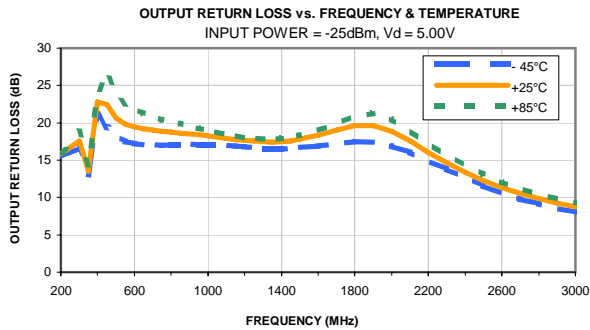
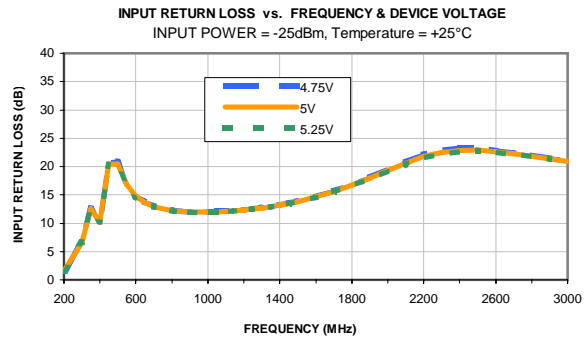
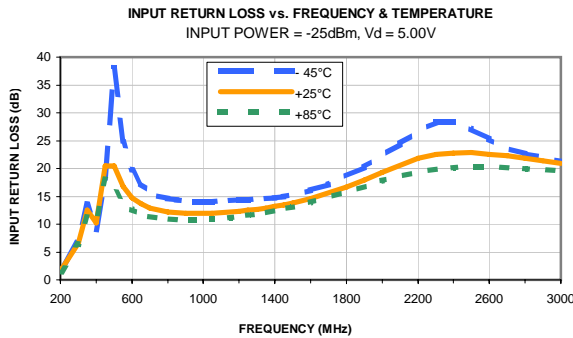
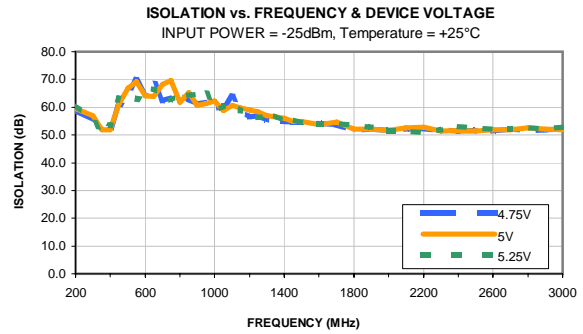
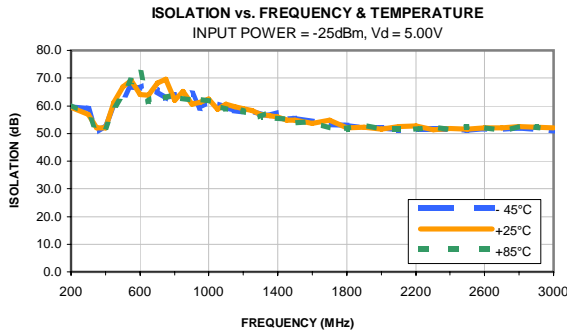
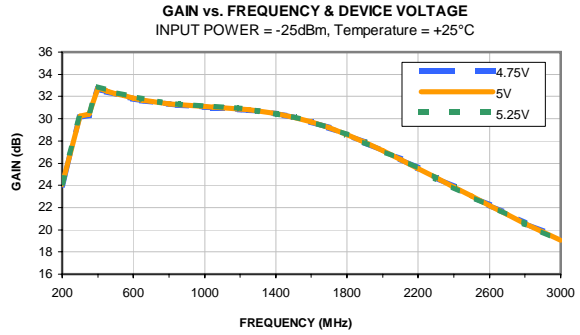
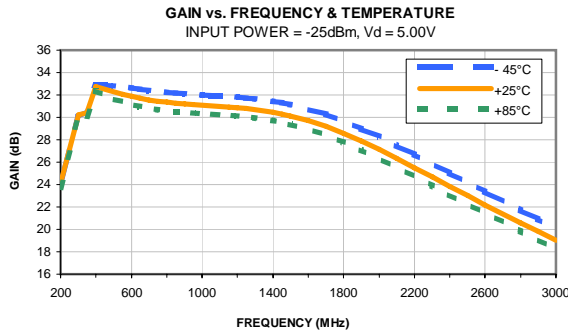

Typical Performance Curves

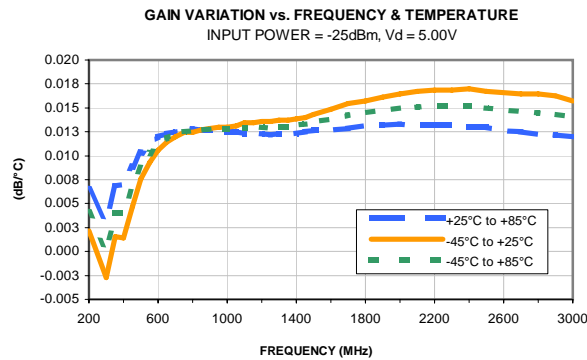
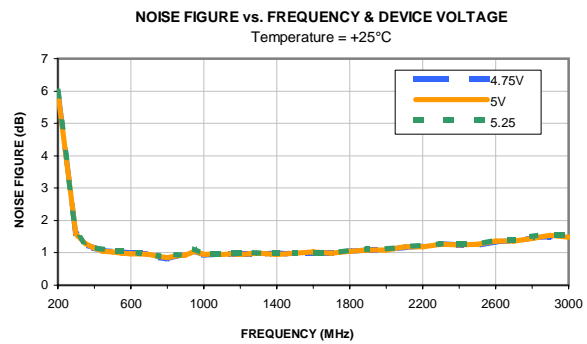
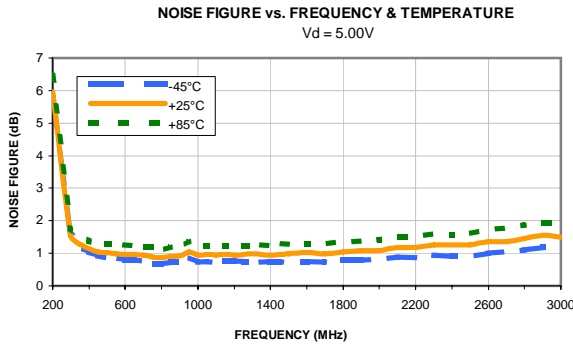
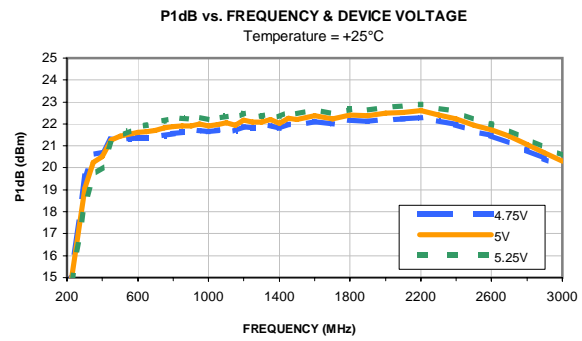
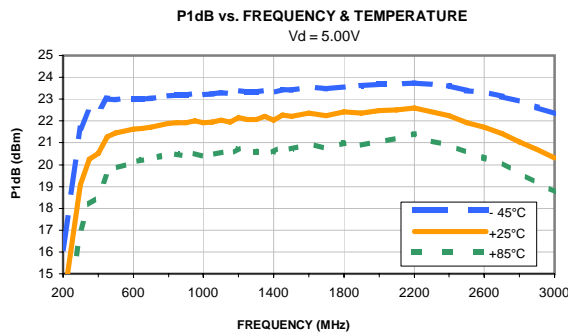
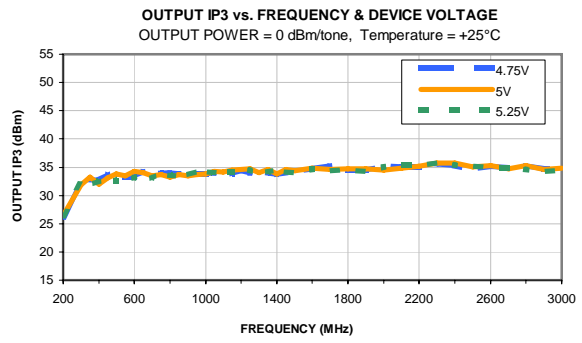
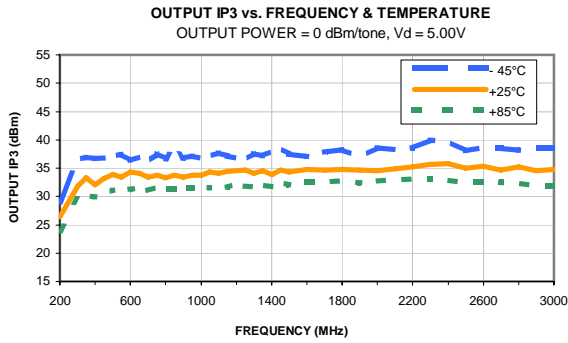

Outline Dimensions

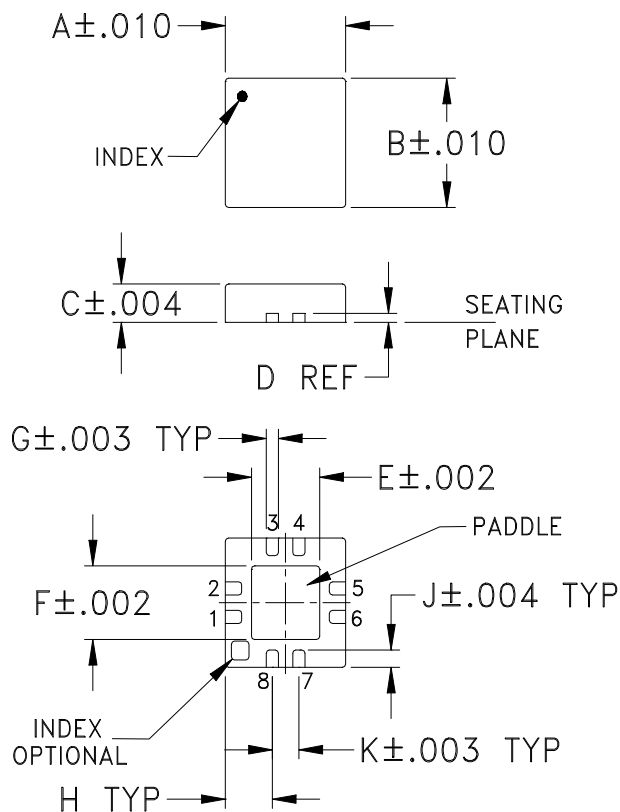

PCB Land Pattern

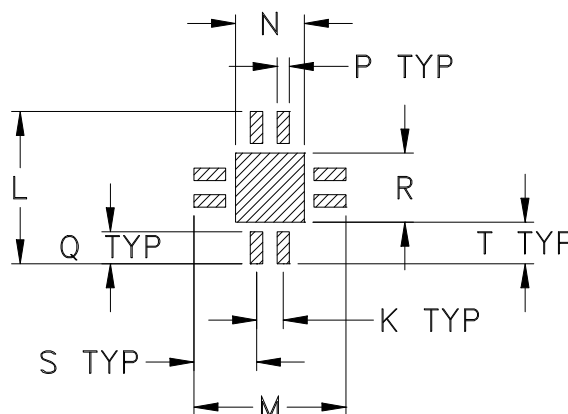

Suggested Layout,
Tolerance to be within $\pm.002$

CASE #	A	B	C	D	E	F	G	H	J	K	L	M	N
DQ849	.118 (3.00)	.118 (3.00)	.035 (0.89)	.008 (0.20)	.067 (1.70)	.067 (1.70)	.012 (0.30)	.046 (1.17)	.016 (0.41)	.026 (0.66)	.148 (3.76)	.148 (3.76)	.067 (1.70)

CASE #	P	Q	R	S	T	WT. GRAM
DQ849	.012 (0.30)	.031 (0.79)	.067 (1.70)	.061 (1.55)	.041 (1.04)	.02

Dimensions are in inches (mm). Tolerances: 2Pl. $\pm.01$; 3 Pl. $\pm.004$

Notes:

- Case material: Plastic.
- Termination finish:
 For RoHS Case Styles: Tin-Silver alloy plate over Nickel barrier or Matte-Tin plated. All models, (+) suffix. See Data sheet.
 For RoHS-5 Case Styles: Tin-Lead plate. All models. no (+) suffix.



INTERNET <http://www.minicircuits.com>

P.O. Box 350166, Brooklyn, New York 11235-0003 (718) 934-4500 Fax (718) 332-4661

Distribution Centers NORTH AMERICA 800-654-7949 • 417-335-5935 • Fax 417-335-5945 • EUROPE 44-1252-832600 • Fax 44-1252-837010

Mini-Circuits ISO 9001 & ISO 14001 Certified

Tape & Reel Packaging TR-F104

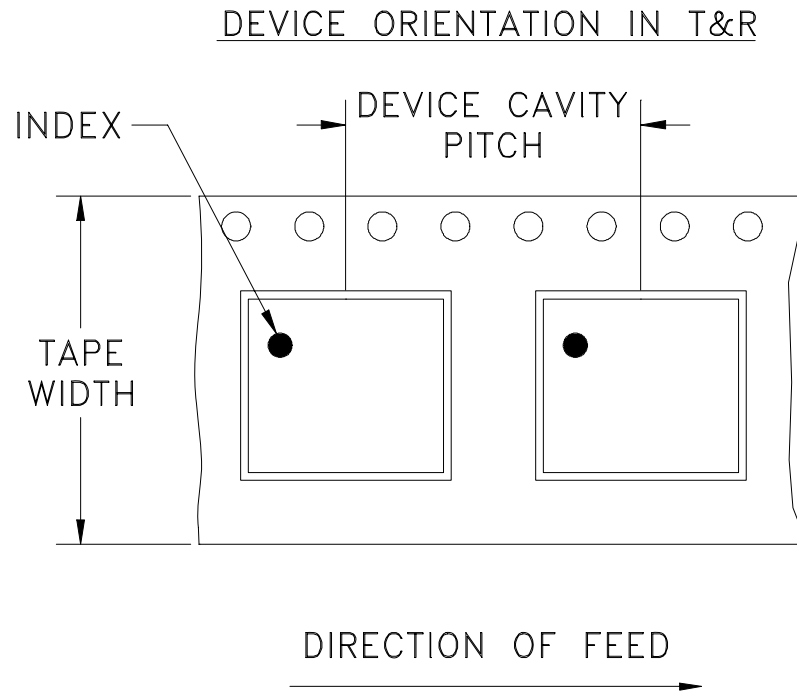

Tape Width, mm	Device Cavity Pitch, mm	Reel Size, inches	Devices per Reel	
8	4	7	Small quantity standards (see note)	20
				50
				100
				200
				500
				1000
		7	Standard	2000

Note: Please Consult individual model data sheet to determine device per reel availability.

Mini-Circuits carrier tape materials provide protection from ESD (Electro-Static Discharge) during handling and transportation. Tapes are static dissipative and comply with industry standards EIA-481/EIA-541.

Go to: www.minicircuits.com/pages/pdfs/tape.pdf

 **Mini-Circuits**[®]

INTERNET <http://www.minicircuits.com>

P.O. Box 350166, Brooklyn, New York 11235-0003 (718) 934-4500 Fax (718) 332-4661

Distribution Centers NORTH AMERICA 800-654-7949 • 417-335-5935 • Fax 417-335-5945 • EUROPE 44-1252-832600 • Fax 44-1252-837010

Mini-Circuits ISO 9001 & ISO 14001 Certified

THIRD ANGLE PROJECTION

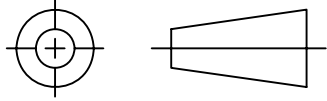

REVISIONS

REV	ECN No.	DESCRIPTION	DATE	DR	AUTH
OR	M131697	NEW RELEASE	05/20/11	PW	MD
A	M132869	UPDATED COMPONENT TABLE AND NOTE 2	07/25/11	IL	RD

SUGGESTED MOUNTING CONFIGURATION FOR
DQ849 CASE STYLE, "08AM08" PIN CODE

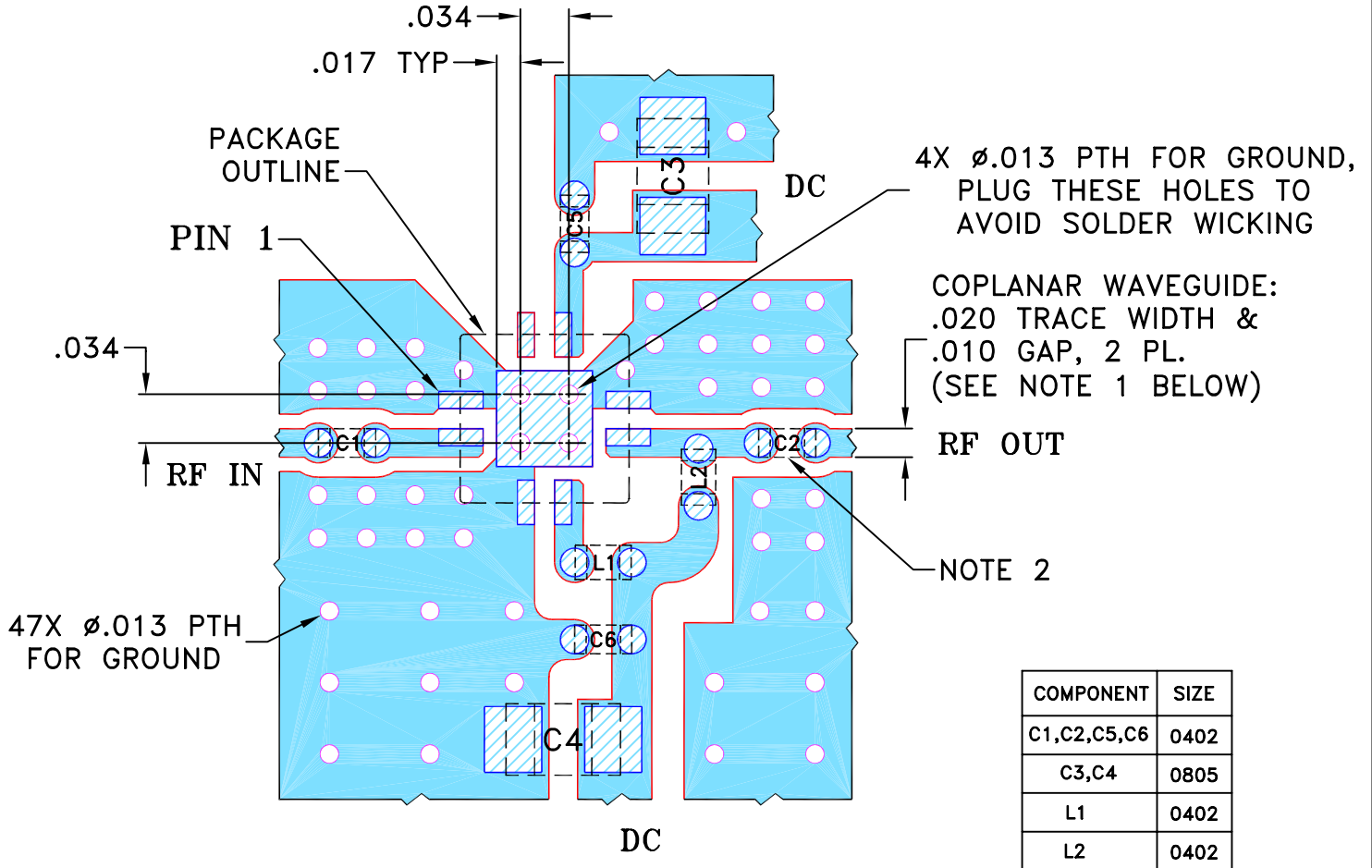

- NOTES: 1. TRACE WIDTH IS SHOWN FOR ROGERS RO4350B WITH DIELECTRIC THICKNESS .010" ± .001"; COPPER: 1/2 OZ. EACH SIDE. FOR OTHER MATERIALS TRACE WIDTH MAY NEED TO BE MODIFIED.
 2. 0805, 0402 SIZES CHIP FOOT PRINTS SHOWN FOR REFERENCE. FOR COMPONENT VALUES REFER TO TB-607+.
 3. BOTTOM SIDE OF THE PCB IS CONTINUOUS GROUND PLANE.

 DENOTES PCB COPPER LAYOUT WITH SMOBC (SOLDER MASK OVER BARE COPPER)
 DENOTES COPPER LAND PATTERN FREE OF SOLDER MASK

UNLESS OTHERWISE SPECIFIED	INITIALS	DATE
DIMENSIONS ARE IN INCHES	DRAWN PW	04/29/11
TOLERANCES ON:	CHECKED AV	05/12/11
2 PL DECIMALS ±	APPROVED MD	05/20/11
3 PL DECIMALS ± .005		
ANGLES ±		
FRACTIONS ±		

 **Mini-Circuits®** 13 Neptune Avenue
Brooklyn NY 11235

PL, 08AM08, DQ849, TB-607+

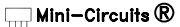
 Mini-Circuits®
 THIS DOCUMENT AND ITS CONTENTS ARE THE PROPERTY OF MINI-CIRCUITS. EXCEPT FOR USE EXPRESSLY GRANTED, IN WRITING, TO ITS VENDORS, VENDOR AND THE UNITED STATES GOVERNMENT, MINI-CIRCUITS RESERVES ALL PROPRIETARY DESIGN, USE, MANUFACTURING AND REPRODUCTION RIGHTS THERETO. THESE CONTENTS SHALL NOT BE USED, DUPLICATED OR DISCLOSED TO ANY OUTSIDE PARTY, IN WHOLE OR IN PART, WITHOUT WRITTEN PERMISSION OF MINI-CIRCUITS.

SIZE	CODE IDENT	DRAWING NO:	REV:
A	15542	98-PL-346	A
FILE:	98PL346	SCALE: 8:1	SHEET: 1 OF 1

Evaluation Board and Circuit

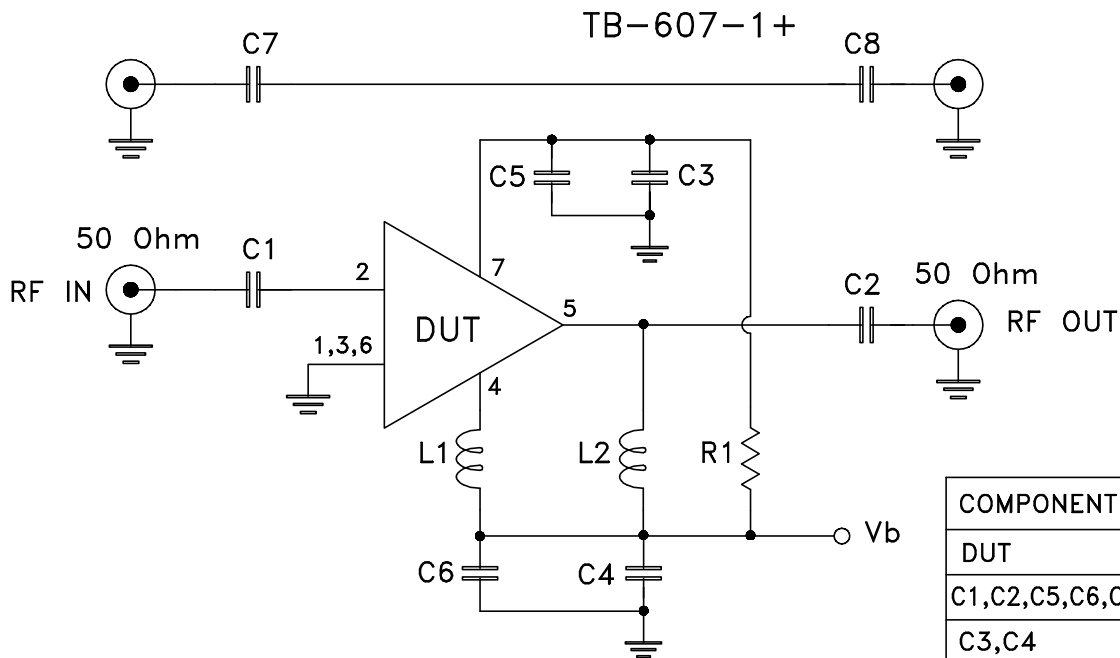
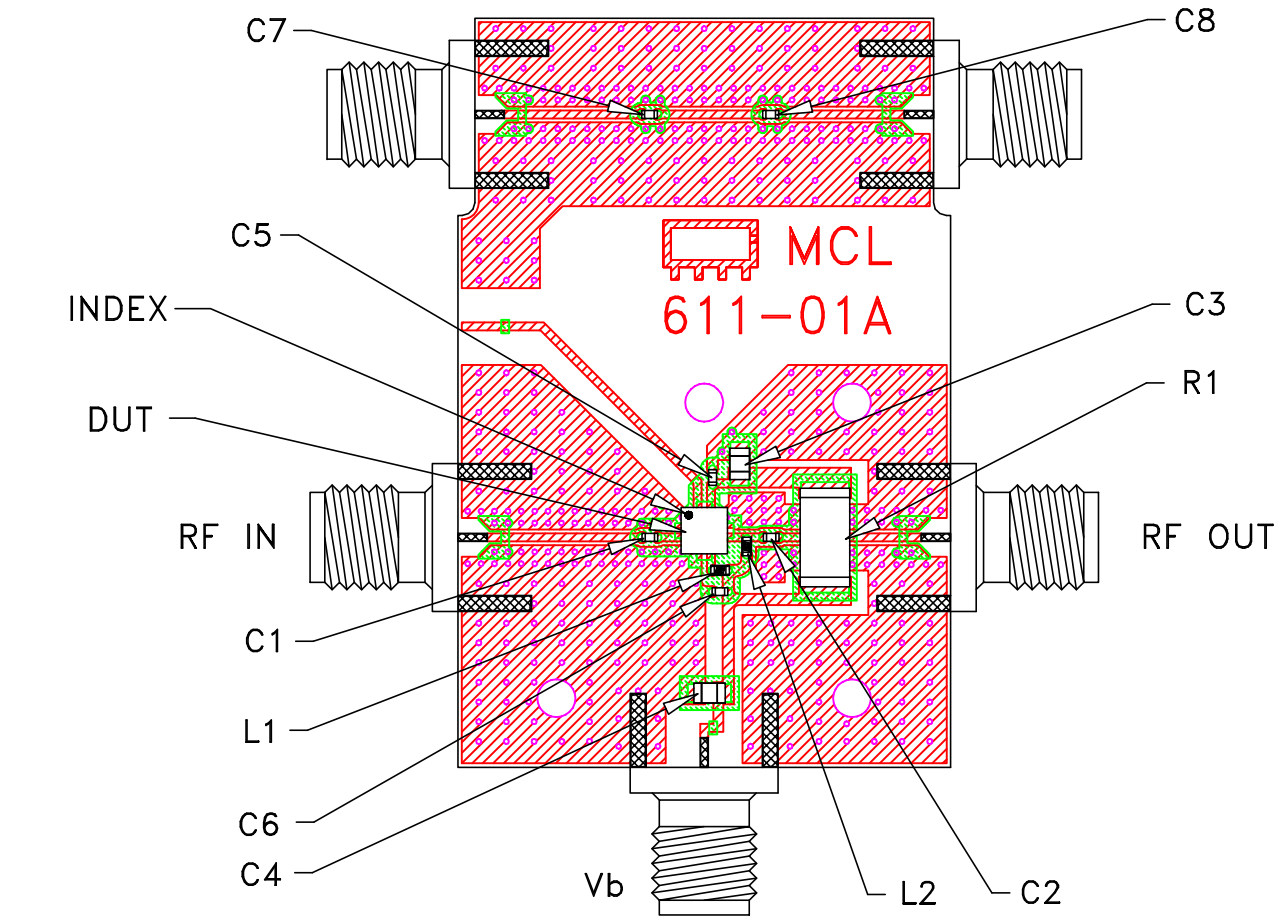

Schematic Diagram

NOTES:

1. SMA Female connectors.
2. PCB material: Rogers R04350 or equivalent, dielectric constant=3.5, dielectric thickness=.010 inch.
3. R1 is a Bridge and perform no RF function. Not required for multilayer Board.

COMPONENT	DESCRIPTION
DUT	PMA-545G1+, MCL
C1,C2,C5,C6,C7,C8	100 pF
C3,C4	1 uF
R1(SEE NOTE 3)	JUMPER, 0 Ohm
L1	36 nH
L2	47 nH

 Mini-Circuits®

All Mini-Circuits products are manufactured under exacting quality assurance and control standards, and are capable of meeting published specifications after being subjected to any or all of the following physical and environmental test.

Specification	Test/Inspection Condition	Reference/Spec
Operating Temperature	-40° to 85° C or -45° to 85° C or -55° to 105° C or -40° to 105° C or -40° to 95° C Ambient Environment	Individual Model Data Sheet
Storage Temperature	-55° to 100° C or -65° to 150° Ambient Environment	Individual Model Data Sheet
HTOL	1000 hours at 125°C	MIL-STD-883, Method 1005, Condition B
Thermal Shock	-55° to 100°C, 100 cycles	MIL-STD-202, Method 107, Condition A-3, except +100°C
Mechanical Shock	1.5Kg, 0.5 ms, 5 shock pulses, Y1 direction only	MIL-STD-883, Method 2002, Condition B, except Y1 direction only
Vibration (Variable Frequency)	50g peak	MIL-STD-883, Method 2007, Condition B
Autoclave	15 psig, 100% RH, 121°C, 96 hours	JESD22-A102, Condition C
HAST	130°C, 85% RH, 96 hours	JESD22-A110
Solderability	10X Magnification	J-STD-002, Para 4.2.5, Test S, 95% Coverage
Solder Reflow Heat	Sn-Pb Eutetic Process: 240°C peak Pb-Free Process: 260°C peak	J-STD-020, Table 4-1, 4-2 and 5-2; Figure 5-1
Moisture Sensitivity: Level 1	Bake at 125°C for 24 hours Soak at 85°C/85% RH for 168 hours, Reflow 3 cycles at 260°C peak	J-STD-020



All Mini-Circuits products are manufactured under exacting quality assurance and control standards, and are capable of meeting published specifications after being subjected to any or all of the following physical and environmental test.

Specification	Test/Inspection Condition	Reference/Spec
Marking Resistance to Solvents	Isopropyl alcohol + mineral spirits at 25°C; terpene defluxer at 25°C; distilled water + proylene glycol monomethyl ether + monoethanolamine at 63°C to 70°C	MIL-STD-202, Method 215