



ULTRA HIGH DYNAMIC RANGE

Monolithic Amplifier

PHA-202+

50Ω 0.03 to 2.7 GHz

THE BIG DEAL

- Ultra High IP3, +46.1 dBm
- Broadband High Dynamic Range without external Matching Components
- Medium power, 1W
- Excellent return loss over 15 dB
- High IP3, +46.1 dBm typ. at 1 GHz
- Gain, 17.0 dB typ. at 1 GHz
- High P_{OUT}, P1dB +30.4 dBm typ. at 1 GHz
- No external matching components required

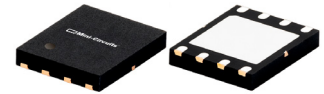

Generic photo used for illustration purposes only

CASE STYLE: DL1636

+RoHS Compliant

The +Suffix identifies RoHS Compliance. See our website for methodologies and qualifications

APPLICATIONS

- Base station infrastructure
- CATV
- LTE

PRODUCT OVERVIEW

The PHA-202+ (RoHS compliant) is a medium power amplifier fabricated using E-PHEMT technology and offers extremely high dynamic range over a broad frequency range and with low noise figure. In addition, the PHA-202+ has good input and output return loss over a broad frequency range without the need for external matching components and has demonstrated excellent reliability. It has repeatable performance from lot to lot and is enclosed in a 5mm x 6mm, 8 lead package for very good thermal performance.

KEY FEATURES

Feature	Advantages
Broad Band: 0.03 to 2.7 GHz	Broadband covering primary wireless communications bands: Cellular, PCS, LTE
Extremely High IP3 Versus DC power Consumption +46 dBm typical at 1.0 GHz	The PHA-202+ matches industry leading IP3 performance relative to device size and power consumption. The combination of the design and E-PHEMT Structure provides enhanced linearity over a broad frequency range as evidence in the IP3 being typically 14-23 dB above the P1dB point. This feature makes this amplifier ideal for use in: <ul style="list-style-type: none"> • Driver amplifiers for complex waveform up converter paths • Drivers in linearized transmit systems • Secondary amplifiers in ultra High Dynamic range receivers
No External Matching Components Required	Unlike competing products, Mini-Circuits PHA-202+ provides Input and Output Return Loss of over 15 dB up to 2 GHz without the need for any external matching components

REV. A
ECO-010399
PHA-202+
MCL NY
240722





ULTRA HIGH DYNAMIC RANGE

Monolithic Amplifier

PHA-202+

Mini-Circuits

50Ω 0.03 to 2.7 GHz

ELECTRICAL SPECIFICATIONS¹ AT +25°C, 50 OHMS, UNLESS NOTED OTHERWISE

Parameter	Condition (MHz)	Vd=+11V ¹			Vd=+11V ²	Units
		Min.	Typ.	Max.	Typ.	
Frequency range		0.03		2.7	0.03-2.7	GHz
Gain	30	—	18.3	—	18.3	dB
	500	—	17.9	—	17.7	
	1000	—	17.0	—	16.8	
	2000	13.2	14.7	16.1	14.3	
	2700	—	12.7	—	12.1	
Input Return Loss	30		21.2		20.5	dB
	500		21.7		25.5	
	1000		19.5		28.6	
	2000		20.3		17.7	
	2700		14.9		12.0	
Output Return Loss	30		15.1		15.5	dB
	500		16.4		15.2	
	1000		19.4		15.7	
	2000		22.5		19.1	
	2700		9.8		9.4	
Reverse Isolation	2000		23		23.3	dB
Output Power @1dB Compression	30		+28.4		+29.2	dBm
	500		+30.2		+29.8	
	1000		+30.4		+29.8	
	2000		+28.1		+27.0	
	2700		+25.7		+25.2	
Output IP ₃ ³	30		+51.0		+50.3	dBm
	500		+48.5		+48.8	
	1000		+46.1		+46.2	
	2000		+43.2		+41.7	
	2700		+39.4		+38.8	
Noise Figure	30		3.2		3.0	dB
	500		3.3		3.0	
	1000		3.5		3.3	
	2000		4.4		4.3	
	2700		5.4		5.2	
Device Operating Voltage			+11		+11	V
Device Operating Current		—	350	416	335	mA
Device Current Variation vs. Temperature ⁴			188.6		188.6	μA/°C
Device Current Variation vs Voltage ⁵			0.0485		0.0485	mA/mV
Thermal Resistance, junction-to-ground lead at 85°C stage temp.			16.1		16.1	°C/W

1. Measured on Mini-Circuits Characterization test board MB018. See Characterization Test Circuit (Fig. 1)

2. Measured on Mini-Circuits Application test board TB-962+. See Characterization Test Circuit (Fig. 2)

3. Tested at P_{out}=16dBm / tone.

4. (Current at 85°C – Current at -45°C)/130

5. (Current at 11.5V-current - Current at 10.5V)/1000





ULTRA HIGH DYNAMIC RANGE

Monolithic Amplifier

PHA-202+

50Ω 0.03 to 2.7 GHz

ABSOLUTE MAXIMUM RATINGS⁶

Parameter	Ratings
Operating Temperature (ground lead)	-40°C to +85°C
Storage Temperature	-65°C to +150°C
Junction Temperature	179°C
Power Dissipation	5.8 W
Input Power (CW)	+24 dBm (5 minutes max.) +19 dBm (continuous)
DC Voltage on Pin 7	+14 V

6. Permanent damage may occur if any of these limits are exceeded. Electrical maximum ratings are not intended for continuous normal operation.

SIMPLIFIED SCHEMATIC AND PIN DESCRIPTION

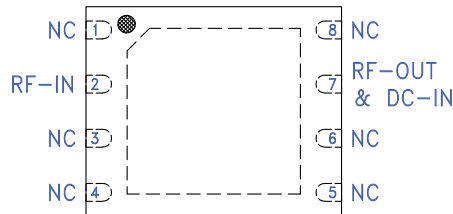
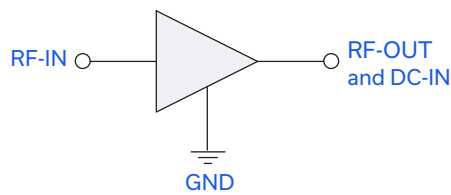

Function	Pin Number	Description
RF-IN	2	RF input
RF-OUT and DC-IN	7	RF output and DC input
GND	Paddle	Ground
NC	1,3-6,8	No connection



ULTRA HIGH DYNAMIC RANGE

Monolithic Amplifier

PHA-202+

Mini-Circuits

50Ω 0.03 to 2.7 GHz

CHARACTERIZATION TEST CIRCUIT

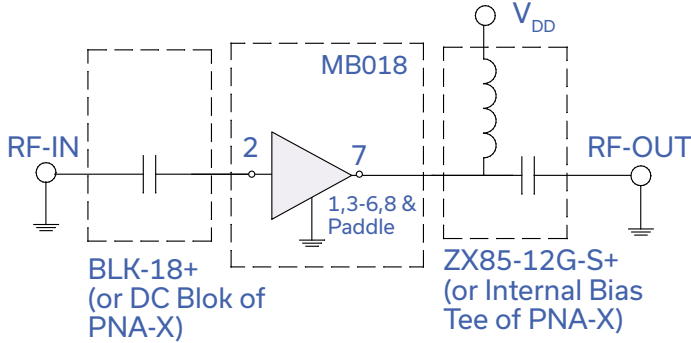

Fig 1. Characterization Circuit

Note: This block diagram is used for characterization. (DUT soldered on Mini-Circuits Characterization test board MB018)
Gain, Return loss, Output power at 1dB compression (P1 dB), output IP3 (OIP3) and noise figure measured using Agilent's N5242A PNA-X microwave network analyzer.

Conditions:

1. Gain and Return loss: $P_{IN} = -25\text{dBm}$
2. Output IP3 (OIP3): Two tones, spaced 1 MHz apart, 16 dBm/tone at output.

RECOMMENDED APPLICATION CIRCUIT

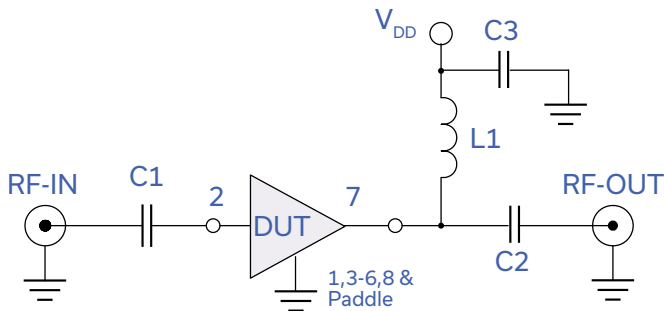

Component	P/N	SUPPLIER	Value	Size
C1, C2, C3	GRM-155R71E103KA01D	MURATA	0.01uF	0402
L1	WA8514-AE	COILCRAFT	5.6uH	1708

Fig 2. Application Circuit

Note: (DUT soldered on Mini-Circuits Application test board TB-962+)
Gain, Return loss, Output power at 1dB compression (P1 dB), output IP3 (OIP3) and noise figure measured using Agilent's N5242A PNA-X microwave network analyzer.

Conditions:

1. Gain and Return loss: $P_{IN} = -25\text{dBm}$
2. Output IP3 (OIP3): Two tones, spaced 1 MHz apart, 16 dBm/tone at output.

PRODUCT MARKING

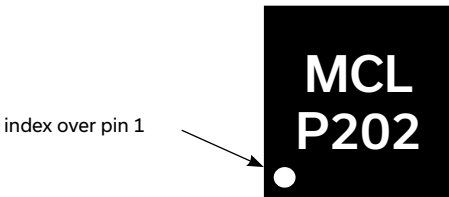

Marking may contain other features or characters for internal lot control





ULTRA HIGH DYNAMIC RANGE

Monolithic Amplifier

PHA-202+

50Ω 0.03 to 2.7 GHz

ADDITIONAL DETAILED TECHNICAL INFORMATION IS AVAILABLE ON OUR DASHBOARD. [CLICK HERE](#)

Performance Data	Data Table Swept Graphs S-Parameter (S2P Files) Data Set (.zip file)
Case Style	DL1636 Plastic package, exposed paddle lead finish: Matte Tin
Tape & Reel Standard quantities available on reel	F68 7" reels with 20, 50, 100, 200, 500 or 1K devices 13" reels with 2K, 3K, 4K devices
Suggested Layout for PCB Design	PL-522
Evaluation Board	TB-962+
Environmental Ratings	ENV08T1

ESD RATING

Human Body Model (HBM): Class 1B (Pass 500V) in accordance with ANSI/ESD STM 5.1 - 2001

MSL RATING

Moisture Sensitivity: MSL1 in accordance with IPC/JEDEC J-STD-020D

- NOTES
- A. Performance and quality attributes and conditions not expressly stated in this specification document are intended to be excluded and do not form a part of this specification document.
 - B. Electrical specifications and performance data contained in this specification document are based on Mini-Circuit's applicable established test performance criteria and measurement instructions.
 - C. The parts covered by this specification document are subject to Mini-Circuits standard limited warranty and terms and conditions (collectively, "Standard Terms"); Purchasers of this part are entitled to the rights and benefits contained therein. For a full statement of the standard. Terms and the exclusive rights and remedies thereunder, please visit Mini-Circuits' website at www.minicircuits.com/MCLStore/terms.jsp



Typical Performance Data

NOTE: Use PDF Bookmarks to view DATA at required conditions

Definitions:

- Input Return Loss = -S11 (dB)
- Gain(Power Gain) = S21 (dB)
- Reverse Isolation = -S12 (dB)
- Output Return Loss = -S22 (dB)

TEST CONDITIONS: Vd = 11V, Id = 348.23 mA @ Temperature = +25degC

FREQ	Gain	Isolation	Input Return Loss	Output Return Loss	Stability		IP-3 Output	1dB Comp. Output	Noise Figure
					K	Measure			
(MHz)	(dB)	(dB)	(dB)	(dB)	K	Measure	(dBm)	(dBm)	(dB)
30	18.34	23.27	21.98	15.44	1.12	0.67	51.27	28.39	3.07
50	18.26	23.16	22.96	15.54	1.12	0.67	51.70	30.30	2.94
100	18.24	23.10	23.04	15.66	1.12	0.66	51.48	29.68	3.04
150	18.22	23.10	23.17	15.74	1.12	0.67	50.11	29.77	3.09
200	18.18	23.09	22.87	15.84	1.13	0.67	50.24	29.97	3.06
250	18.14	23.11	22.85	15.94	1.13	0.67	50.33	30.23	3.07
300	18.10	23.09	22.53	16.08	1.13	0.68	49.61	30.37	3.12
350	18.05	23.06	22.34	16.25	1.13	0.68	48.97	30.31	3.11
400	17.99	23.04	22.14	16.39	1.14	0.68	48.79	30.20	3.11
450	17.93	23.05	21.87	16.64	1.14	0.69	48.56	30.19	3.14
500	17.87	23.01	21.63	16.83	1.15	0.69	48.45	30.15	3.17
550	17.80	23.02	21.33	17.09	1.15	0.70	47.81	30.41	3.21
600	17.73	23.03	21.12	17.35	1.16	0.71	47.55	30.39	3.24
650	17.65	23.02	20.80	17.68	1.16	0.71	47.18	30.38	3.25
700	17.56	23.01	20.57	18.00	1.17	0.72	46.90	30.34	3.28
750	17.48	23.00	20.33	18.34	1.18	0.72	46.61	30.27	3.31
800	17.39	22.98	20.12	18.71	1.18	0.73	46.35	30.15	3.33
850	17.29	22.99	19.99	19.07	1.19	0.74	46.08	30.40	3.35
900	17.19	22.96	19.72	19.52	1.20	0.74	46.19	30.32	3.39
950	17.09	22.95	19.63	19.96	1.21	0.75	45.71	30.00	3.41
1000	16.99	22.95	19.46	20.52	1.22	0.76	45.95	30.38	3.43
1050	16.89	22.94	19.35	20.97	1.23	0.76	45.35	30.12	3.48
1100	16.78	22.95	19.30	21.55	1.24	0.77	45.45	30.10	3.52
1150	16.67	22.92	19.26	22.15	1.25	0.78	45.12	29.91	3.57
1200	16.56	22.92	19.22	22.79	1.26	0.78	45.24	30.19	3.62
1250	16.45	22.90	19.23	23.54	1.27	0.79	44.97	29.58	3.66
1300	16.33	22.90	19.27	24.29	1.28	0.79	45.07	29.93	3.71
1350	16.22	22.91	19.31	25.22	1.29	0.80	44.98	29.41	3.76
1400	16.11	22.89	19.34	26.20	1.30	0.80	44.65	29.60	3.80
1450	15.99	22.88	19.44	27.15	1.31	0.81	44.93	29.83	3.84
1500	15.87	22.86	19.58	28.23	1.32	0.81	44.59	29.54	3.88
1550	15.76	22.90	19.69	29.41	1.34	0.82	44.61	29.50	3.94
1600	15.64	22.88	19.84	30.36	1.35	0.82	44.25	29.12	3.98
1650	15.52	22.87	20.02	30.97	1.36	0.83	43.97	28.74	4.03
1700	15.41	22.85	20.15	30.86	1.38	0.83	43.44	28.38	4.07
1750	15.29	22.87	20.41	30.07	1.39	0.84	43.67	28.64	4.22
1800	15.17	22.90	20.63	28.83	1.41	0.84	43.48	28.52	4.13
1850	15.06	22.93	20.76	27.45	1.42	0.85	43.85	29.08	4.21
1900	14.94	22.92	20.87	25.87	1.44	0.85	43.23	28.41	4.21
1950	14.82	22.92	21.03	24.46	1.45	0.85	42.96	28.10	4.26
2000	14.70	22.95	21.13	22.86	1.47	0.86	42.96	28.06	4.31
2100	14.45	22.97	21.01	20.49	1.49	0.86	42.71	27.66	4.38
2200	14.20	23.07	20.67	18.42	1.53	0.87	41.85	27.26	4.48
2300	13.95	23.10	20.00	16.53	1.55	0.87	40.95	26.63	4.59
2400	13.69	23.26	19.19	14.83	1.59	0.88	40.49	26.47	4.71
2500	13.41	23.38	18.23	13.30	1.62	0.88	39.26	25.63	4.85
2600	13.11	23.50	17.18	11.86	1.65	0.88	38.72	25.24	5.00
2700	12.78	23.73	16.05	10.53	1.68	0.87	38.98	25.75	5.18

Typical Performance Data

Definitions:

Input Return Loss = -S11 (dB)

Gain(Power Gain) = S21 (dB)

Reverse Isolation = -S12 (dB)

Output Return Loss = -S22 (dB)

TEST CONDITIONS: Vd = 10.5V, Id = 322.53 mA @ Temperature = +25degC

FREQ	Gain	Isolation	Input Return Loss	Output Return Loss	Stability		IP-3 Output	1dB Comp. Output	Noise Figure
					K	Measure			
(MHz)	(dB)	(dB)	(dB)	(dB)	K	Measure	(dBm)	(dBm)	(dB)
30	18.32	23.24	21.77	15.52	1.12	0.66	51.15	28.02	3.02
50	18.25	23.12	22.82	15.62	1.12	0.66	51.93	29.82	2.89
100	18.24	23.10	22.85	15.72	1.12	0.66	49.91	29.28	2.99
150	18.21	23.08	22.96	15.80	1.12	0.67	50.26	29.39	3.03
200	18.18	23.06	22.68	15.91	1.12	0.67	50.05	29.51	3.01
250	18.13	23.06	22.65	16.00	1.13	0.67	49.87	29.77	3.01
300	18.09	23.07	22.37	16.15	1.13	0.68	48.57	29.91	3.07
350	18.04	23.06	22.17	16.31	1.13	0.68	48.82	29.85	3.07
400	17.98	23.04	21.98	16.48	1.14	0.68	47.94	29.74	3.07
450	17.92	23.02	21.71	16.68	1.14	0.69	47.63	29.74	3.10
500	17.86	23.02	21.48	16.92	1.15	0.69	47.20	29.75	3.13
550	17.78	23.03	21.21	17.15	1.15	0.70	47.00	30.00	3.15
600	17.72	23.03	20.93	17.46	1.16	0.71	46.64	29.92	3.17
650	17.63	23.00	20.63	17.75	1.16	0.71	46.32	29.92	3.19
700	17.55	23.01	20.48	18.07	1.17	0.72	46.08	29.87	3.23
750	17.46	22.97	20.21	18.44	1.18	0.72	45.57	29.81	3.22
800	17.37	22.99	20.01	18.79	1.19	0.73	45.31	29.77	3.28
850	17.27	22.96	19.87	19.16	1.19	0.74	45.27	29.94	3.29
900	17.17	22.95	19.64	19.62	1.20	0.74	45.09	29.94	3.35
950	17.07	22.95	19.54	20.09	1.21	0.75	44.52	29.55	3.37
1000	16.97	22.94	19.36	20.63	1.22	0.76	44.93	29.90	3.40
1050	16.86	22.92	19.30	21.13	1.23	0.76	44.33	29.73	3.43
1100	16.75	22.94	19.18	21.69	1.24	0.77	44.40	29.64	3.47
1150	16.64	22.92	19.21	22.24	1.25	0.78	44.00	29.45	3.50
1200	16.53	22.91	19.14	22.94	1.26	0.78	44.15	29.73	3.55
1250	16.42	22.92	19.17	23.68	1.27	0.79	43.65	29.22	3.61
1300	16.30	22.88	19.21	24.39	1.28	0.79	43.81	29.55	3.64
1350	16.18	22.93	19.24	25.23	1.30	0.80	43.58	29.05	3.68
1400	16.08	22.89	19.27	26.19	1.30	0.81	43.36	29.22	3.74
1450	15.95	22.87	19.37	27.09	1.31	0.81	43.75	29.43	3.78
1500	15.83	22.84	19.53	27.93	1.32	0.81	43.26	29.14	3.83
1550	15.72	22.87	19.61	28.90	1.34	0.82	43.24	29.10	3.87
1600	15.59	22.88	19.81	29.38	1.36	0.83	42.82	28.74	3.93
1650	15.47	22.92	19.98	29.59	1.37	0.83	42.44	28.37	3.94
1700	15.36	22.88	20.12	29.29	1.38	0.83	41.96	28.02	3.99
1750	15.24	22.90	20.36	28.51	1.40	0.84	42.21	28.27	4.05
1800	15.12	22.89	20.57	27.39	1.41	0.84	41.99	28.15	4.08
1850	15.00	22.91	20.70	26.20	1.43	0.85	42.52	28.68	4.14
1900	14.88	22.90	20.82	24.88	1.44	0.85	41.79	28.03	4.14
1950	14.76	22.91	20.99	23.65	1.45	0.85	41.47	27.73	4.17
2000	14.62	22.94	21.07	21.98	1.47	0.86	41.58	27.68	4.22
2100	14.37	22.96	20.91	19.82	1.50	0.86	41.03	27.28	4.30
2200	14.12	23.05	20.59	17.93	1.53	0.87	40.46	26.97	4.41
2300	13.87	23.13	19.93	16.14	1.56	0.87	39.45	26.25	4.51
2400	13.60	23.21	19.11	14.55	1.59	0.88	39.12	26.08	4.61
2500	13.31	23.34	18.16	13.06	1.62	0.88	37.64	25.34	4.77
2600	13.01	23.51	17.14	11.70	1.66	0.88	37.04	24.86	4.92
2700	12.68	23.73	16.03	10.41	1.69	0.87	37.95	25.36	5.10

Typical Performance Data

Definitions:

Input Return Loss = -S11 (dB)

Gain(Power Gain) = S21 (dB)

Reverse Isolation = -S12 (dB)

Output Return Loss = -S22 (dB)

TEST CONDITIONS: Vd = 11.5V, Id = 371.94 mA @ Temperature = +25degC

FREQ	Gain	Isolation	Input Return Loss	Output Return Loss	Stability		IP-3 Output	1dB Comp. Output	Noise Figure
					K	Measure			
(MHz)	(dB)	(dB)	(dB)	(dB)	K	Measure	(dBm)	(dBm)	(dB)
30	18.36	23.27	22.03	15.31	1.12	0.67	50.91	28.70	3.12
50	18.27	23.20	23.17	15.36	1.12	0.67	51.62	30.67	3.00
100	18.26	23.13	23.22	15.61	1.12	0.66	50.36	30.07	3.08
150	18.23	23.10	23.43	15.65	1.12	0.66	51.67	30.09	3.12
200	18.19	23.08	23.09	15.76	1.12	0.67	50.33	30.31	3.10
250	18.15	23.10	23.07	15.86	1.13	0.67	50.51	30.58	3.11
300	18.12	23.09	22.75	16.01	1.13	0.67	49.24	30.72	3.16
350	18.06	23.09	22.49	16.18	1.14	0.68	49.55	30.65	3.16
400	18.01	23.08	22.34	16.34	1.14	0.68	49.10	30.58	3.18
450	17.95	23.06	22.04	16.56	1.14	0.69	48.82	30.52	3.19
500	17.89	23.04	21.83	16.73	1.15	0.69	48.59	30.54	3.22
550	17.82	23.04	21.47	16.99	1.15	0.70	48.10	30.80	3.24
600	17.75	23.06	21.27	17.25	1.16	0.70	48.18	30.72	3.28
650	17.67	23.04	20.92	17.57	1.16	0.71	47.62	30.72	3.30
700	17.59	23.01	20.70	17.89	1.17	0.72	47.30	30.67	3.33
750	17.51	23.02	20.48	18.22	1.18	0.72	47.09	30.60	3.36
800	17.42	22.99	20.22	18.60	1.18	0.73	46.88	30.55	3.37
850	17.32	23.01	20.10	18.92	1.19	0.74	46.80	30.73	3.39
900	17.23	22.97	19.83	19.38	1.20	0.74	46.69	30.73	3.45
950	17.13	22.98	19.73	19.81	1.21	0.75	46.28	30.32	3.47
1000	17.03	22.95	19.58	20.34	1.21	0.75	46.50	30.71	3.52
1050	16.93	22.94	19.44	20.81	1.22	0.76	46.26	30.44	3.54
1100	16.82	22.94	19.40	21.33	1.23	0.77	46.05	30.42	3.57
1150	16.71	22.93	19.36	21.94	1.24	0.77	45.90	30.23	3.62
1200	16.60	22.94	19.35	22.53	1.25	0.78	45.81	30.52	3.68
1250	16.49	22.92	19.32	23.30	1.26	0.78	45.89	29.89	3.72
1300	16.38	22.92	19.36	24.04	1.28	0.79	45.99	30.24	3.76
1350	16.27	22.92	19.39	25.03	1.29	0.80	45.39	29.72	3.81
1400	16.16	22.90	19.45	25.94	1.30	0.80	45.99	29.92	3.87
1450	16.05	22.90	19.53	26.98	1.31	0.81	45.77	30.15	3.91
1500	15.93	22.89	19.63	28.22	1.32	0.81	45.55	29.86	3.95
1550	15.82	22.89	19.80	29.57	1.33	0.82	45.67	29.83	3.99
1600	15.70	22.87	19.94	30.99	1.35	0.82	45.15	29.43	4.08
1650	15.58	22.89	20.12	32.25	1.36	0.83	44.99	29.04	4.10
1700	15.47	22.86	20.28	32.95	1.37	0.83	44.55	28.59	4.12
1750	15.36	22.92	20.52	32.29	1.39	0.83	44.69	28.95	4.16
1800	15.24	22.92	20.72	30.78	1.40	0.84	44.53	28.74	4.22
1850	15.13	22.91	20.90	29.08	1.42	0.84	44.83	29.41	4.29
1900	15.01	22.87	20.94	27.31	1.42	0.84	44.28	28.71	4.29
1950	14.90	22.92	21.10	25.59	1.44	0.85	43.96	28.41	4.33
2000	14.74	23.00	21.15	23.62	1.47	0.86	44.12	28.37	4.36
2100	14.51	22.98	21.04	21.01	1.49	0.86	43.40	27.97	4.45
2200	14.26	23.06	20.67	18.76	1.52	0.87	43.26	27.57	4.55
2300	14.01	23.14	20.01	16.79	1.55	0.87	41.99	26.86	4.67
2400	13.75	23.22	19.20	15.02	1.58	0.88	41.79	26.69	4.77
2500	13.47	23.37	18.24	13.43	1.61	0.88	40.36	25.94	4.93
2600	13.17	23.52	17.19	11.96	1.64	0.87	39.75	25.46	5.10
2700	12.85	23.75	16.07	10.60	1.68	0.87	40.85	25.99	5.27

Typical Performance Data

Definitions:

Input Return Loss = -S11 (dB)

Gain(Power Gain) = S21 (dB)

Reverse Isolation = -S12 (dB)

Output Return Loss = -S22 (dB)

TEST CONDITIONS: Vd = 11V, Id = 332.89 mA @ Temperature = -45degC

FREQ	Gain	Isolation	Input Return Loss	Output Return Loss	Stability		IP-3 Output	1dB Comp. Output	Noise Figure
					K	Measure			
(MHz)	(dB)	(dB)	(dB)	(dB)	K	Measure	(dBm)	(dBm)	(dB)
30	18.19	23.19	22.27	15.42	1.12	0.67	51.72	28.40	2.59
50	18.30	23.11	22.50	15.79	1.12	0.66	53.25	30.37	2.43
100	18.29	23.14	22.30	15.99	1.12	0.67	51.91	29.80	2.51
150	18.26	23.09	22.30	16.12	1.12	0.67	51.39	29.85	2.56
200	18.23	23.09	22.04	16.22	1.12	0.67	51.59	30.05	2.53
250	18.19	23.09	22.20	16.25	1.13	0.67	50.90	30.34	2.54
300	18.15	23.05	22.15	16.27	1.13	0.67	50.61	30.48	2.58
350	18.10	23.06	22.09	16.37	1.13	0.68	50.45	30.42	2.57
400	18.04	23.08	21.97	16.48	1.14	0.68	49.97	30.35	2.57
450	17.99	23.07	21.69	16.70	1.14	0.69	49.26	30.35	2.59
500	17.92	23.04	21.44	16.91	1.14	0.69	49.25	30.22	2.61
550	17.85	23.01	21.16	17.17	1.15	0.70	48.70	30.58	2.66
600	17.78	23.03	20.97	17.41	1.15	0.70	48.61	30.48	2.65
650	17.71	22.99	20.77	17.62	1.16	0.71	48.02	30.47	2.68
700	17.62	23.02	20.67	17.87	1.17	0.72	47.98	30.41	2.69
750	17.54	23.00	20.49	18.13	1.17	0.72	47.50	30.26	2.73
800	17.45	22.97	20.26	18.48	1.18	0.72	47.44	30.21	2.74
850	17.36	22.94	20.18	18.77	1.18	0.73	47.37	30.49	2.78
900	17.27	22.95	19.96	19.17	1.19	0.74	47.06	30.39	2.79
950	17.17	22.94	19.91	19.53	1.20	0.74	46.65	29.98	2.81
1000	17.07	22.92	19.81	19.94	1.21	0.75	46.97	30.37	2.84
1050	16.97	22.91	19.73	20.34	1.21	0.76	46.58	30.20	2.86
1100	16.86	22.94	19.69	20.78	1.23	0.76	46.65	30.11	2.89
1150	16.75	22.92	19.65	21.24	1.24	0.77	46.39	30.01	2.93
1200	16.65	22.90	19.63	21.78	1.25	0.77	46.56	30.31	2.95
1250	16.54	22.89	19.64	22.38	1.25	0.78	46.17	29.68	3.01
1300	16.43	22.89	19.68	22.88	1.27	0.79	46.19	30.04	3.05
1350	16.32	22.88	19.75	23.49	1.28	0.79	46.11	29.52	3.09
1400	16.22	22.89	19.80	24.12	1.29	0.80	45.86	29.72	3.12
1450	16.10	22.85	19.92	24.70	1.30	0.80	46.35	29.97	3.17
1500	15.99	22.84	20.04	25.29	1.31	0.81	45.94	29.70	3.21
1550	15.88	22.84	20.19	25.88	1.32	0.81	46.04	29.65	3.25
1600	15.76	22.85	20.35	26.26	1.33	0.82	45.41	29.37	3.29
1650	15.64	22.84	20.60	26.54	1.35	0.82	45.08	28.90	3.34
1700	15.54	22.84	20.79	26.58	1.36	0.82	44.50	28.54	3.36
1750	15.42	22.85	21.08	26.41	1.37	0.83	44.72	28.91	3.41
1800	15.31	22.83	21.36	25.89	1.38	0.83	44.59	28.70	3.42
1850	15.20	22.84	21.58	25.27	1.40	0.83	45.06	29.38	3.48
1900	15.09	22.84	21.73	24.56	1.41	0.84	44.38	28.69	3.48
1950	14.97	22.83	22.01	23.62	1.42	0.84	43.94	28.39	3.51
2000	14.86	22.86	22.33	22.27	1.43	0.84	44.03	28.35	3.54
2100	14.63	22.92	22.47	20.47	1.47	0.85	43.32	27.98	3.60
2200	14.40	22.89	22.31	18.74	1.48	0.86	43.09	27.60	3.71
2300	14.17	22.96	21.86	17.12	1.51	0.86	41.84	26.90	3.78
2400	13.93	23.03	21.11	15.56	1.54	0.86	41.66	26.76	3.87
2500	13.68	23.13	20.09	14.10	1.56	0.87	39.97	25.93	4.02
2600	13.42	23.28	19.03	12.71	1.60	0.87	39.28	25.44	4.15
2700	13.13	23.45	17.81	11.40	1.62	0.86	40.59	25.97	4.30

Typical Performance Data

Definitions:

Input Return Loss = -S11 (dB)

Gain(Power Gain) = S21 (dB)

Reverse Isolation = -S12 (dB)

Output Return Loss = -S22 (dB)

TEST CONDITIONS: Vd = 10.5V, Id = 305.28 mA @ Temperature = -45degC

FREQ	Gain	Isolation	Input Return Loss	Output Return Loss	Stability		IP-3 Output	1dB Comp. Output	Noise Figure
					K	Measure			
(MHz)	(dB)	(dB)	(dB)	(dB)	K	Measure	(dBm)	(dBm)	(dB)
30	18.19	23.11	22.08	15.43	1.12	0.67	52.07	28.02	2.53
50	18.29	23.18	22.25	15.76	1.12	0.67	52.69	29.94	2.39
100	18.28	23.10	22.13	16.07	1.12	0.67	50.95	29.37	2.49
150	18.25	23.06	22.10	16.23	1.12	0.67	53.63	29.48	2.51
200	18.21	23.06	21.85	16.33	1.12	0.67	50.89	29.62	2.49
250	18.17	23.07	21.96	16.35	1.13	0.67	51.58	29.90	2.50
300	18.13	23.08	21.89	16.41	1.13	0.68	50.16	30.04	2.54
350	18.08	23.06	21.89	16.48	1.13	0.68	50.31	30.02	2.53
400	18.02	23.05	21.76	16.59	1.14	0.68	49.51	29.91	2.53
450	17.97	23.02	21.53	16.80	1.14	0.69	48.58	29.91	2.55
500	17.90	23.02	21.31	17.01	1.14	0.69	48.84	29.85	2.57
550	17.83	23.04	21.04	17.23	1.15	0.70	48.19	30.13	2.61
600	17.77	23.04	20.87	17.48	1.16	0.71	48.12	30.02	2.63
650	17.69	22.97	20.65	17.72	1.16	0.71	47.42	30.02	2.63
700	17.60	22.98	20.57	17.95	1.16	0.71	47.25	29.95	2.65
750	17.52	22.96	20.36	18.23	1.17	0.72	46.87	29.82	2.70
800	17.43	22.98	20.18	18.56	1.18	0.73	46.71	29.85	2.70
850	17.34	23.00	20.07	18.87	1.19	0.74	46.56	30.04	2.72
900	17.24	22.94	19.87	19.26	1.19	0.74	46.46	30.04	2.75
950	17.14	22.96	19.84	19.65	1.20	0.75	45.90	29.64	2.77
1000	17.05	22.91	19.72	20.08	1.21	0.75	46.24	30.01	2.79
1050	16.94	22.91	19.65	20.45	1.22	0.76	45.87	29.76	2.81
1100	16.84	22.92	19.59	20.89	1.23	0.76	45.82	29.76	2.84
1150	16.73	22.90	19.60	21.37	1.24	0.77	45.46	29.66	2.90
1200	16.62	22.90	19.54	21.90	1.25	0.78	45.61	29.87	2.90
1250	16.51	22.88	19.53	22.48	1.26	0.78	45.16	29.35	2.97
1300	16.40	22.88	19.58	23.02	1.27	0.79	45.30	29.70	3.00
1350	16.29	22.88	19.65	23.62	1.28	0.79	44.95	29.20	3.04
1400	16.18	22.85	19.73	24.22	1.29	0.80	44.92	29.39	3.08
1450	16.07	22.84	19.82	24.72	1.30	0.80	45.26	29.61	3.12
1500	15.95	22.84	20.00	25.22	1.31	0.81	44.80	29.34	3.15
1550	15.84	22.81	20.08	25.80	1.32	0.81	44.88	29.30	3.20
1600	15.72	22.83	20.24	26.10	1.34	0.82	44.25	29.04	3.23
1650	15.60	22.83	20.45	26.25	1.35	0.82	43.84	28.67	3.26
1700	15.50	22.83	20.69	26.24	1.36	0.82	43.23	28.24	3.30
1750	15.38	22.83	20.95	25.93	1.37	0.83	43.54	28.60	3.35
1800	15.27	22.85	21.22	25.36	1.39	0.83	43.30	28.49	3.37
1850	15.15	22.79	21.46	24.75	1.40	0.83	43.91	29.03	3.42
1900	15.04	22.81	21.60	23.98	1.41	0.84	43.11	28.39	3.42
1950	14.92	22.81	21.86	23.13	1.42	0.84	42.72	28.10	3.43
2000	14.80	22.86	22.15	21.76	1.44	0.85	42.80	27.99	3.48
2100	14.57	22.86	22.30	20.03	1.46	0.85	42.15	27.61	3.55
2200	14.34	22.92	22.06	18.35	1.49	0.86	41.72	27.23	3.63
2300	14.10	22.97	21.69	16.78	1.52	0.86	40.47	26.54	3.72
2400	13.86	23.03	20.90	15.29	1.54	0.87	40.30	26.39	3.81
2500	13.61	23.11	19.97	13.85	1.57	0.87	38.46	25.65	3.99
2600	13.34	23.27	18.89	12.52	1.60	0.87	37.80	25.17	4.08
2700	13.05	23.41	17.71	11.24	1.62	0.86	39.19	25.68	4.22

Typical Performance Data

Definitions:

Input Return Loss = -S11 (dB)

Gain(Power Gain) = S21 (dB)

Reverse Isolation = -S12 (dB)

Output Return Loss = -S22 (dB)

TEST CONDITIONS: Vd = 11.5V, Id = 357.91 mA @ Temperature = -45degC

FREQ	Gain	Isolation	Input Return Loss	Output Return Loss	Stability		IP-3 Output	1dB Comp. Output	Noise Figure
					K	Measure			
(MHz)	(dB)	(dB)	(dB)	(dB)	K	Measure	(dBm)	(dBm)	(dB)
30	18.18	23.10	22.38	15.41	1.12	0.67	52.20	28.73	2.64
50	18.33	23.18	22.80	15.50	1.12	0.66	53.46	30.75	2.48
100	18.32	23.14	22.52	15.87	1.12	0.66	52.47	30.15	2.55
150	18.29	23.12	22.50	15.98	1.12	0.66	52.34	30.17	2.59
200	18.25	23.10	22.22	16.11	1.12	0.67	51.72	30.41	2.56
250	18.21	23.10	22.36	16.13	1.12	0.67	51.63	30.70	2.57
300	18.18	23.08	22.32	16.17	1.13	0.67	51.36	30.88	2.61
350	18.12	23.08	22.23	16.25	1.13	0.68	50.57	30.81	2.61
400	18.07	23.05	22.18	16.34	1.13	0.68	50.37	30.70	2.60
450	18.02	23.07	21.89	16.57	1.14	0.68	49.75	30.69	2.63
500	17.95	23.06	21.69	16.74	1.14	0.69	49.34	30.63	2.65
550	17.88	23.06	21.42	16.99	1.15	0.70	48.98	30.93	2.68
600	17.82	23.04	21.23	17.20	1.15	0.70	48.99	30.81	2.70
650	17.74	23.02	21.01	17.42	1.16	0.70	48.35	30.80	2.72
700	17.66	23.02	20.88	17.67	1.16	0.71	48.20	30.73	2.74
750	17.58	23.03	20.68	17.95	1.17	0.72	47.83	30.57	2.74
800	17.49	22.98	20.49	18.25	1.17	0.72	47.59	30.52	2.77
850	17.40	22.99	20.41	18.54	1.18	0.73	47.72	30.81	2.81
900	17.31	22.98	20.15	18.93	1.19	0.74	47.42	30.71	2.83
950	17.21	22.98	20.13	19.28	1.20	0.74	47.01	30.29	2.85
1000	17.12	22.97	20.00	19.71	1.21	0.75	47.46	30.69	2.88
1050	17.01	22.96	19.90	20.07	1.21	0.75	47.12	30.51	2.89
1100	16.91	22.94	19.89	20.50	1.22	0.76	47.03	30.42	2.94
1150	16.80	22.92	19.84	21.02	1.23	0.77	46.96	30.32	2.97
1200	16.70	22.92	19.82	21.50	1.24	0.77	47.14	30.63	3.00
1250	16.59	22.89	19.80	22.12	1.25	0.78	46.80	29.89	3.06
1300	16.49	22.88	19.87	22.60	1.26	0.78	47.01	30.34	3.09
1350	16.37	22.89	19.91	23.26	1.27	0.79	46.70	29.72	3.13
1400	16.27	22.90	19.97	23.91	1.28	0.79	47.05	30.03	3.18
1450	16.16	22.87	20.06	24.52	1.29	0.80	47.17	30.29	3.21
1500	16.04	22.86	20.18	25.19	1.31	0.80	46.87	30.02	3.25
1550	15.94	22.85	20.32	25.87	1.32	0.81	47.04	29.96	3.29
1600	15.82	22.86	20.48	26.41	1.33	0.81	46.49	29.59	3.32
1650	15.71	22.84	20.72	26.79	1.34	0.82	46.09	29.19	3.38
1700	15.60	22.85	20.93	27.02	1.35	0.82	45.59	28.74	3.39
1750	15.49	22.86	21.19	26.97	1.37	0.83	45.88	29.11	3.45
1800	15.38	22.85	21.45	26.65	1.38	0.83	45.70	28.91	3.46
1850	15.27	22.82	21.73	26.02	1.39	0.83	46.12	29.70	3.53
1900	15.16	22.82	21.87	25.31	1.40	0.84	45.44	28.90	3.52
1950	15.05	22.88	22.14	24.37	1.42	0.84	45.04	28.60	3.55
2000	14.91	22.86	22.42	22.73	1.43	0.84	45.23	28.56	3.60
2100	14.68	22.86	22.61	20.91	1.45	0.85	44.35	28.19	3.67
2200	14.45	22.93	22.39	19.06	1.48	0.86	44.23	27.81	3.75
2300	14.22	22.96	21.97	17.38	1.51	0.86	42.93	27.12	3.84
2400	13.99	23.04	21.19	15.79	1.54	0.86	42.79	26.98	3.93
2500	13.74	23.14	20.20	14.27	1.56	0.87	41.19	26.14	4.09
2600	13.47	23.28	19.10	12.86	1.59	0.87	40.56	25.66	4.20
2700	13.20	23.43	17.92	11.52	1.62	0.86	41.68	26.28	4.36

Typical Performance Data

Definitions:

Input Return Loss = -S11 (dB)

Gain(Power Gain) = S21 (dB)

Reverse Isolation = -S12 (dB)

Output Return Loss = -S22 (dB)

TEST CONDITIONS: Vd = 11V, Id = 350.92mA @ Temperature = +85degC

FREQ	Gain	Isolation	Input Return Loss	Output Return Loss	Stability		IP-3 Output	1dB Comp. Output	Noise Figure
					K	Measure			
(MHz)	(dB)	(dB)	(dB)	(dB)	K	Measure	(dBm)	(dBm)	(dB)
30	18.30	23.23	22.25	15.26	1.13	0.67	48.57	28.35	3.50
50	18.15	23.03	22.97	15.59	1.12	0.67	48.67	30.10	3.37
100	18.13	23.06	23.07	15.85	1.13	0.67	48.04	29.54	3.47
150	18.10	23.04	23.27	15.89	1.13	0.67	47.71	29.64	3.50
200	18.07	23.05	22.93	16.02	1.13	0.67	47.64	29.81	3.49
250	18.03	23.04	22.89	16.14	1.13	0.68	47.70	30.02	3.53
300	17.99	23.02	22.53	16.30	1.14	0.68	47.24	30.15	3.56
350	17.93	23.03	22.27	16.53	1.14	0.69	46.87	30.08	3.58
400	17.88	23.03	22.02	16.70	1.15	0.69	46.67	30.01	3.55
450	17.82	22.98	21.67	16.98	1.15	0.69	46.29	30.01	3.60
500	17.75	23.01	21.44	17.18	1.16	0.70	46.08	29.99	3.62
550	17.68	22.98	21.08	17.48	1.16	0.71	45.89	30.21	3.63
600	17.61	22.97	20.82	17.78	1.16	0.71	45.73	30.14	3.68
650	17.52	22.96	20.49	18.14	1.17	0.72	45.32	30.13	3.73
700	17.44	22.98	20.24	18.50	1.18	0.73	45.08	30.16	3.73
750	17.35	22.95	20.02	18.89	1.18	0.73	44.82	30.04	3.74
800	17.26	22.93	19.74	19.33	1.19	0.74	44.63	30.00	3.76
850	17.16	22.96	19.61	19.73	1.20	0.74	44.62	30.20	3.86
900	17.07	22.93	19.31	20.25	1.21	0.75	44.57	30.15	3.88
950	16.96	22.94	19.21	20.76	1.22	0.76	44.08	29.96	3.90
1000	16.86	22.90	19.03	21.38	1.23	0.76	44.48	30.11	3.94
1050	16.75	22.91	18.88	22.00	1.24	0.77	43.95	29.94	3.98
1100	16.64	22.91	18.82	22.63	1.25	0.78	43.98	29.84	4.01
1150	16.53	22.90	18.81	23.36	1.26	0.78	43.66	29.72	4.08
1200	16.42	22.88	18.76	24.14	1.27	0.79	43.79	29.87	4.12
1250	16.30	22.91	18.74	25.14	1.28	0.80	43.38	29.40	4.13
1300	16.19	22.91	18.78	26.07	1.29	0.80	43.53	29.70	4.22
1350	16.07	22.91	18.78	27.41	1.31	0.81	43.23	29.22	4.26
1400	15.96	22.91	18.81	28.85	1.32	0.81	43.30	29.36	4.36
1450	15.84	22.88	18.91	30.76	1.33	0.82	43.52	29.48	4.39
1500	15.72	22.91	18.98	33.18	1.35	0.82	43.20	29.17	4.41
1550	15.60	22.92	19.12	36.50	1.36	0.83	43.14	29.24	4.50
1600	15.47	22.92	19.22	41.72	1.38	0.83	42.69	28.75	4.50
1650	15.35	22.95	19.36	44.32	1.39	0.84	42.32	28.49	4.58
1700	15.24	22.93	19.48	38.08	1.40	0.84	41.80	28.03	4.61
1750	15.12	22.95	19.63	33.49	1.42	0.85	42.07	28.27	4.67
1800	14.99	22.95	19.77	30.42	1.43	0.85	41.85	28.15	4.70
1850	14.87	22.98	19.88	27.94	1.45	0.85	42.48	28.64	4.77
1900	14.75	22.99	19.87	25.91	1.47	0.86	41.68	28.00	4.78
1950	14.62	23.01	19.96	24.17	1.48	0.86	41.39	27.69	4.84
2000	14.48	23.03	19.98	22.48	1.50	0.87	41.44	27.65	4.91
2100	14.22	23.14	19.79	19.84	1.54	0.88	40.99	27.25	4.97
2200	13.95	23.18	19.33	17.64	1.57	0.88	40.43	26.91	5.11
2300	13.68	23.29	18.67	15.73	1.61	0.88	39.45	26.27	5.19
2400	13.39	23.42	17.83	14.01	1.64	0.89	39.13	26.08	5.33
2500	13.07	23.57	16.89	12.45	1.68	0.88	37.85	25.32	5.50
2600	12.75	23.78	15.89	11.03	1.72	0.88	37.38	24.84	5.65
2700	12.38	24.00	14.83	9.73	1.75	0.87	37.93	25.33	5.85

Typical Performance Data

Definitions:

Input Return Loss = -S11 (dB)

Gain(Power Gain) = S21 (dB)

Reverse Isolation = -S12 (dB)

Output Return Loss = -S22 (dB)

TEST CONDITIONS: Vd = 10.5V, Id = 327.21 mA @ Temperature = +85degC

FREQ	Gain	Isolation	Input Return Loss	Output Return Loss	Stability		IP-3 Output	1dB Comp. Output	Noise Figure
					K	Measure			
(MHz)	(dB)	(dB)	(dB)	(dB)	K	Measure	(dBm)	(dBm)	(dB)
30	18.28	23.13	22.07	15.29	1.12	0.67	48.76	27.94	3.40
50	18.14	23.13	22.94	15.64	1.13	0.67	48.87	29.63	3.29
100	18.13	23.03	22.91	15.89	1.13	0.67	48.29	29.17	3.40
150	18.10	23.03	23.09	15.93	1.13	0.67	47.85	29.26	3.44
200	18.06	23.03	22.78	16.05	1.13	0.67	47.67	29.36	3.42
250	18.02	23.05	22.70	16.17	1.14	0.68	47.76	29.57	3.44
300	17.98	23.03	22.34	16.34	1.14	0.68	47.07	29.69	3.48
350	17.92	23.00	22.04	16.56	1.14	0.69	46.95	29.63	3.47
400	17.87	23.01	21.86	16.74	1.14	0.69	46.38	29.57	3.46
450	17.81	22.97	21.52	17.02	1.15	0.69	46.20	29.57	3.50
500	17.74	22.99	21.27	17.23	1.15	0.70	45.81	29.54	3.54
550	17.67	22.97	20.96	17.52	1.16	0.71	45.85	29.76	3.59
600	17.59	22.97	20.69	17.84	1.17	0.71	45.41	29.69	3.59
650	17.51	22.96	20.36	18.22	1.17	0.72	45.21	29.74	3.62
700	17.42	22.97	20.13	18.58	1.18	0.73	44.84	29.71	3.64
750	17.34	22.96	19.89	18.98	1.19	0.73	44.55	29.65	3.71
800	17.24	22.96	19.61	19.44	1.19	0.74	44.29	29.62	3.71
850	17.14	22.94	19.50	19.82	1.20	0.75	44.24	29.75	3.73
900	17.04	22.91	19.22	20.38	1.21	0.75	44.12	29.69	3.79
950	16.94	22.90	19.09	20.92	1.22	0.76	43.58	29.50	3.81
1000	16.83	22.90	18.93	21.55	1.23	0.76	44.04	29.72	3.84
1050	16.72	22.91	18.81	22.13	1.24	0.77	43.45	29.56	3.88
1100	16.61	22.90	18.75	22.81	1.25	0.78	43.52	29.46	3.92
1150	16.50	22.86	18.71	23.61	1.26	0.78	43.09	29.27	3.98
1200	16.39	22.89	18.70	24.38	1.27	0.79	43.34	29.42	4.02
1250	16.27	22.90	18.64	25.42	1.28	0.80	42.78	29.03	4.08
1300	16.15	22.89	18.70	26.38	1.30	0.80	42.92	29.25	4.12
1350	16.03	22.88	18.74	27.76	1.31	0.81	42.71	28.85	4.17
1400	15.92	22.90	18.75	29.29	1.32	0.81	42.57	28.91	4.22
1450	15.80	22.91	18.84	31.14	1.34	0.82	42.93	29.10	4.26
1500	15.67	22.89	18.94	33.41	1.35	0.82	42.53	28.72	4.30
1550	15.55	22.90	19.05	36.18	1.36	0.83	42.40	28.78	4.36
1600	15.43	22.92	19.15	38.72	1.38	0.84	41.97	28.38	4.43
1650	15.31	22.92	19.32	38.19	1.39	0.84	41.53	28.04	4.45
1700	15.19	22.93	19.44	34.90	1.41	0.84	40.96	27.68	4.50
1750	15.06	22.93	19.59	31.72	1.42	0.85	41.30	27.91	4.54
1800	14.94	22.91	19.70	29.25	1.44	0.85	41.03	27.78	4.60
1850	14.82	22.95	19.85	27.07	1.45	0.86	41.73	28.19	4.65
1900	14.69	22.98	19.84	25.20	1.47	0.86	40.84	27.64	4.68
1950	14.57	22.94	19.92	23.64	1.48	0.86	40.55	27.33	4.71
2000	14.41	22.99	19.96	21.87	1.50	0.87	40.66	27.28	4.75
2100	14.15	23.10	19.77	19.46	1.54	0.88	40.00	26.87	4.86
2200	13.88	23.13	19.27	17.36	1.57	0.88	39.57	26.53	4.96
2300	13.60	23.26	18.63	15.54	1.61	0.88	38.49	25.89	5.09
2400	13.31	23.39	17.80	13.88	1.65	0.89	38.30	25.69	5.19
2500	12.99	23.52	16.87	12.36	1.68	0.89	36.81	24.94	5.33
2600	12.66	23.73	15.87	10.98	1.72	0.88	36.26	24.46	5.53
2700	12.30	23.99	14.81	9.70	1.76	0.87	37.29	24.94	5.70

Typical Performance Data

Definitions:

Input Return Loss = -S11 (dB)

Gain(Power Gain) = S21 (dB)

Reverse Isolation = -S12 (dB)

Output Return Loss = -S22 (dB)

TEST CONDITIONS: Vd = 11.5V, Id = 371.66 mA @ Temperature = +85degC

FREQ	Gain	Isolation	Input Return Loss	Output Return Loss	Stability		IP-3 Output	1dB Comp. Output	Noise Figure
					K	Measure			
(MHz)	(dB)	(dB)	(dB)	(dB)	K	Measure	(dBm)	(dBm)	(dB)
30	18.30	23.20	22.39	15.21	1.12	0.67	48.11	28.66	3.61
50	18.14	23.04	23.14	15.72	1.12	0.67	47.81	30.46	3.49
100	18.13	23.05	23.22	15.87	1.13	0.67	47.30	29.92	3.59
150	18.10	23.03	23.41	15.91	1.13	0.67	47.41	29.95	3.62
200	18.07	23.03	23.10	16.03	1.13	0.67	47.04	30.14	3.60
250	18.03	23.04	23.04	16.15	1.14	0.68	47.17	30.39	3.62
300	17.99	23.06	22.67	16.32	1.14	0.68	46.57	30.51	3.67
350	17.93	23.03	22.36	16.53	1.14	0.69	46.71	30.44	3.68
400	17.88	23.00	22.15	16.69	1.14	0.69	46.30	30.34	3.68
450	17.82	22.99	21.77	16.98	1.15	0.69	45.97	30.34	3.71
500	17.76	22.98	21.55	17.17	1.15	0.70	45.89	30.31	3.74
550	17.68	23.00	21.19	17.46	1.16	0.71	45.79	30.54	3.79
600	17.62	22.99	20.92	17.76	1.17	0.71	45.54	30.47	3.81
650	17.53	22.96	20.59	18.12	1.17	0.72	45.39	30.52	3.82
700	17.45	22.98	20.33	18.44	1.18	0.72	45.13	30.48	3.85
750	17.37	22.93	20.09	18.85	1.18	0.73	44.73	30.43	3.85
800	17.27	22.93	19.84	19.27	1.19	0.74	44.66	30.39	3.92
850	17.18	22.98	19.66	19.66	1.20	0.74	44.49	30.53	3.93
900	17.08	22.96	19.39	20.22	1.21	0.75	44.51	30.47	3.99
950	16.98	22.94	19.26	20.71	1.22	0.76	44.05	30.28	4.01
1000	16.88	22.94	19.05	21.31	1.23	0.76	44.51	30.50	4.06
1050	16.78	22.96	18.93	21.88	1.24	0.77	44.00	30.26	4.10
1100	16.67	22.95	18.88	22.51	1.25	0.78	44.10	30.15	4.13
1150	16.55	22.92	18.81	23.25	1.26	0.78	43.73	30.03	4.20
1200	16.45	22.90	18.80	23.95	1.27	0.79	43.88	30.18	4.23
1250	16.33	22.94	18.75	24.92	1.28	0.79	43.58	29.70	4.30
1300	16.22	22.90	18.79	25.83	1.29	0.80	43.66	30.01	4.34
1350	16.10	22.91	18.80	27.11	1.30	0.80	43.55	29.52	4.40
1400	16.00	22.92	18.83	28.55	1.32	0.81	43.36	29.67	4.46
1450	15.87	22.93	18.89	30.26	1.33	0.82	43.76	29.79	4.49
1500	15.75	22.94	18.99	32.66	1.35	0.82	43.40	29.40	4.54
1550	15.64	22.91	19.10	35.63	1.36	0.82	43.31	29.48	4.60
1600	15.51	22.93	19.21	41.76	1.37	0.83	42.96	29.04	4.63
1650	15.39	22.92	19.36	56.57	1.39	0.83	42.60	28.71	4.71
1700	15.28	22.94	19.47	40.90	1.40	0.84	42.14	28.33	4.74
1750	15.16	22.95	19.62	34.99	1.42	0.84	42.40	28.57	4.83
1800	15.04	22.98	19.75	31.46	1.43	0.85	42.23	28.37	4.82
1850	14.92	22.98	19.84	28.56	1.45	0.85	42.79	28.87	4.89
1900	14.80	23.00	19.86	26.35	1.46	0.86	42.08	28.30	4.93
1950	14.68	23.07	19.95	24.59	1.49	0.86	41.79	27.91	4.97
2000	14.52	23.04	20.00	22.83	1.50	0.87	41.95	27.95	5.01
2100	14.26	23.14	19.81	20.07	1.54	0.87	41.46	27.55	5.12
2200	14.00	23.20	19.32	17.83	1.57	0.88	40.82	27.13	5.22
2300	13.73	23.32	18.64	15.83	1.61	0.88	39.95	26.49	5.37
2400	13.44	23.42	17.81	14.07	1.64	0.88	39.57	26.31	5.48
2500	13.13	23.58	16.87	12.48	1.67	0.88	38.47	25.55	5.65
2600	12.80	23.80	15.85	11.05	1.71	0.88	38.01	25.07	5.81
2700	12.44	24.04	14.80	9.73	1.74	0.87	38.30	25.57	6.01

Typical Performance Curves

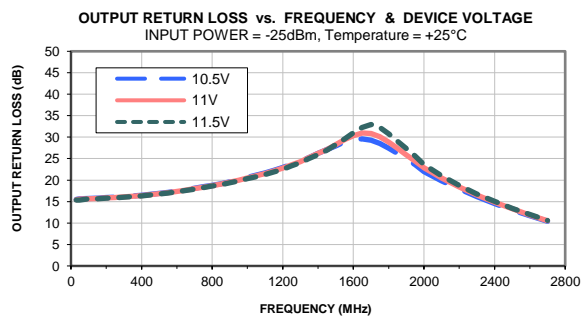
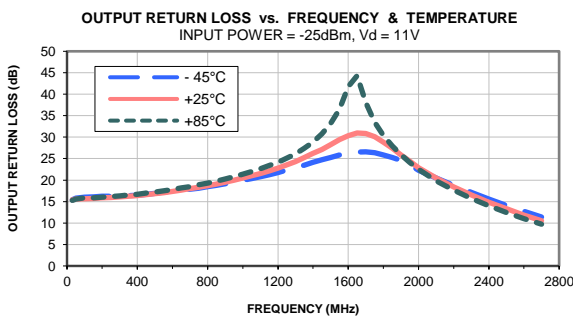
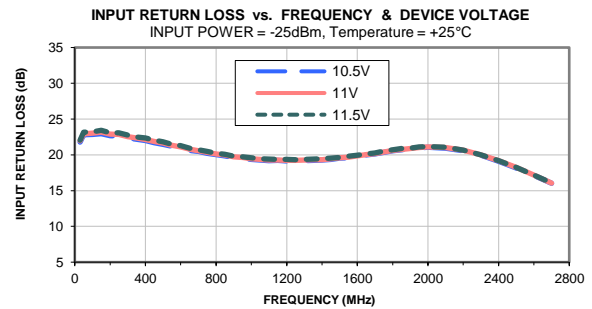
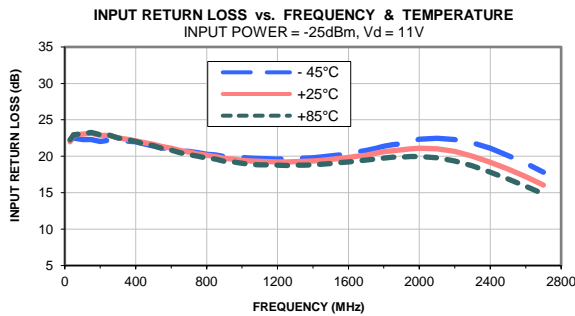
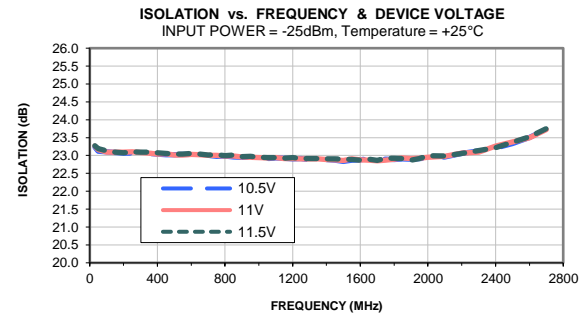
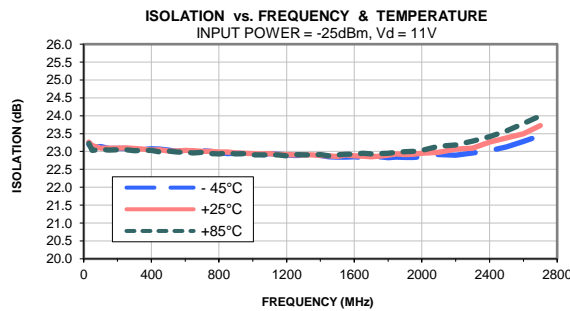
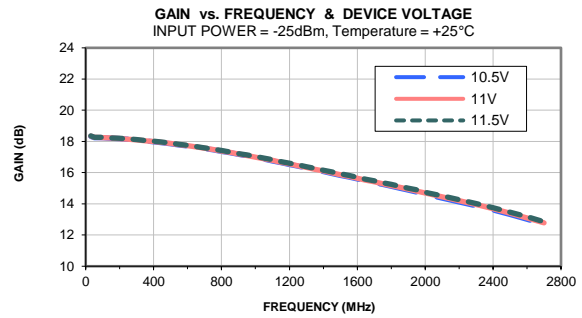
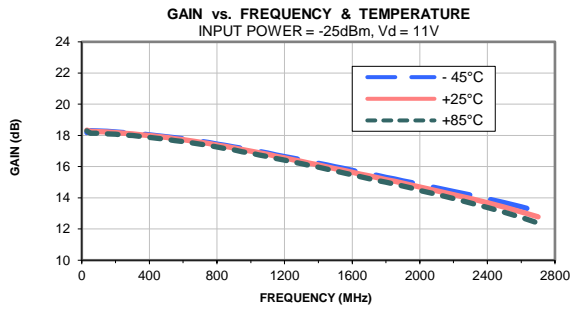

Typical Performance Curves

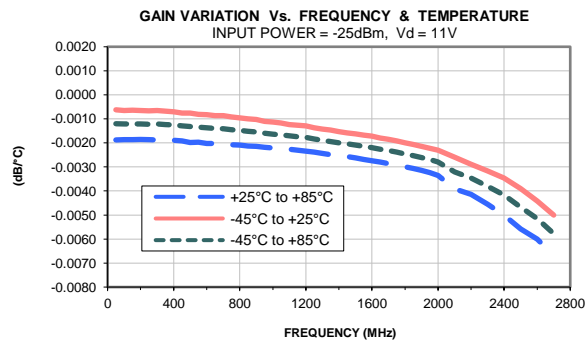
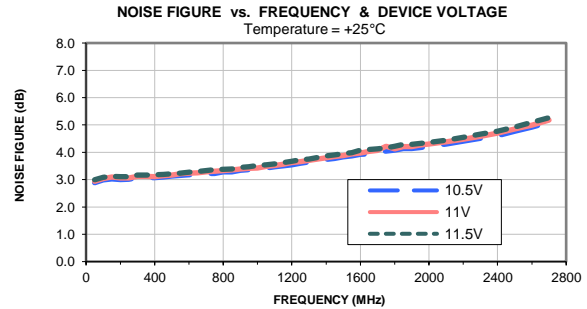
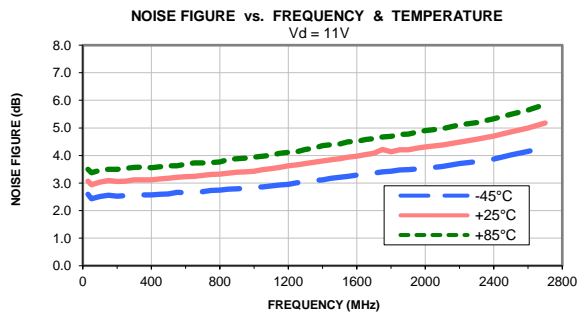
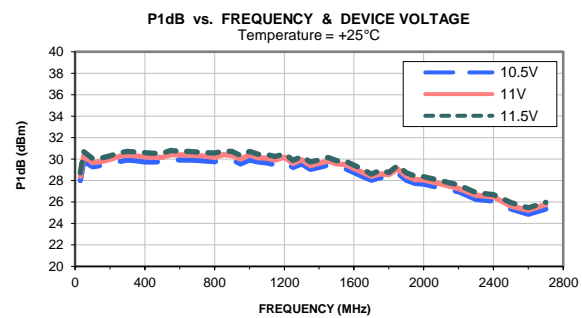
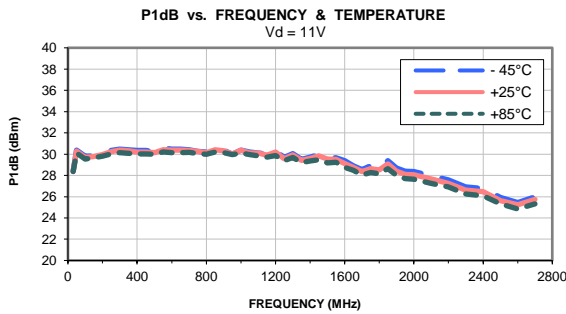
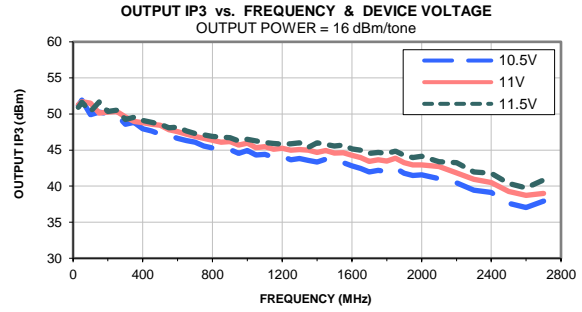
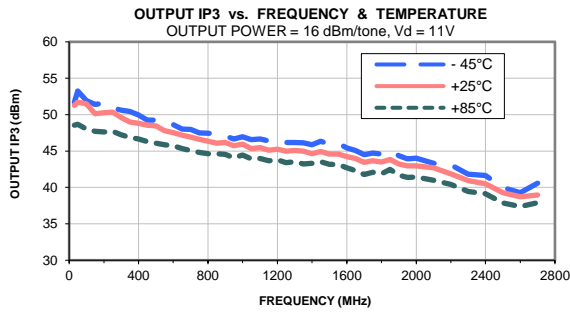

Outline Dimensions

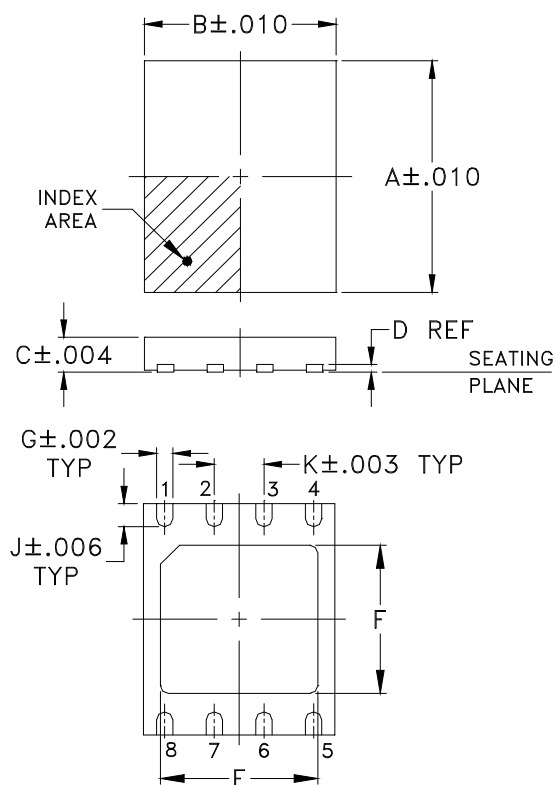

PCB Land Pattern

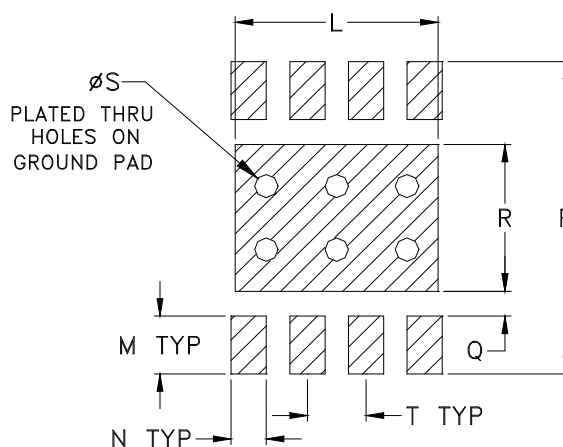

Suggested Layout,
Tolerance to be within $\pm .002$

CASE #	A	B	C	D	E	F	G	H	J	K	L	M	N
DL1636	.236 (6.00)	.193 (4.90)	.035 (0.90)	.008 (0.20)	.160 (4.05)	.153 (3.89)	.017 (0.42)	-- --	.024 (0.60)	.050 (1.27)	.162 (4.11)	.040 (1.02)	.020 (0.51)

CASE #	P	Q	R	S	T	WT. GRAM
DL1636	.257 (6.53)	.011 (0.28)	.155 (3.94)	.020 (0.51)	.050 (1.27)	.08

Dimensions are in inches (mm). Tolerances: 3Pl. $\pm .004$, unless otherwise specified.

Notes:

- Case material: Plastic.
- Termination finish:
For RoHS Case Styles: Tin-Silver-Nickel plate or Matte-Tin. All models, (+) suffix. See model data sheet.
For RoHS-5 Case Styles: Tin-Lead plate. All models, no (+) suffix.



P.O. Box 350166, Brooklyn, New York 11235-0003 (718) 934-4500 Fax (718) 332-4661 For detailed performance specs & shopping online see Mini-Circuits web site



The Design Engineers Search Engine Provides ACTUAL Data Instantly From MINI-CIRCUITS At: www.minicircuits.com

RF/IF MICROWAVE COMPONENTS

Tape & Reel Packaging TR-F68

DEVICE ORIENTATION IN T&R



Tape Width, mm	Device Cavity Pitch, mm	Reel Size, inches	Devices per Reel see note	
12	8	7	Small quantity standard	20
				50
				100
				200
				500
		7	Standard	1000
		13	Standard	2000
				3000
				4000

Mini-Circuits carrier tape materials provide protection from ESD (Electro-Static Discharge) during handling and transportation. Tapes are static dissipative and comply with industry standards EIA-481/EIA-541.

Go to: www.minicircuits.com/pages/pdfs/tape.pdf



INTERNET <http://www.minicircuits.com>

P.O. Box 350166, Brooklyn, New York 11235-0003 (718) 934-4500 Fax (718) 332-4661

Distribution Centers NORTH AMERICA 800-654-7949 • 417-335-5935 • Fax 417-335-5945 • EUROPE 44-1252-832600 • Fax 44-1252-837010

Mini-Circuits ISO 9001 & ISO 14001 Certified

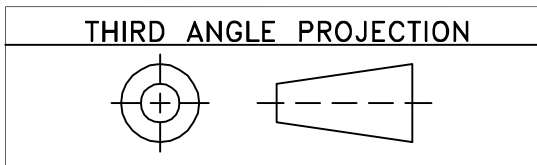

REVISIONS					
REV OR	ECN No.	DESCRIPTION	DATE	DR	AUTH
	M163284	NEW RELEASE	08/11/17	CA	RS

SUGGESTED MOUNTING CONFIGURATION FOR DL1636 CASE STYLE, "08AM09" PIN CONNECTION

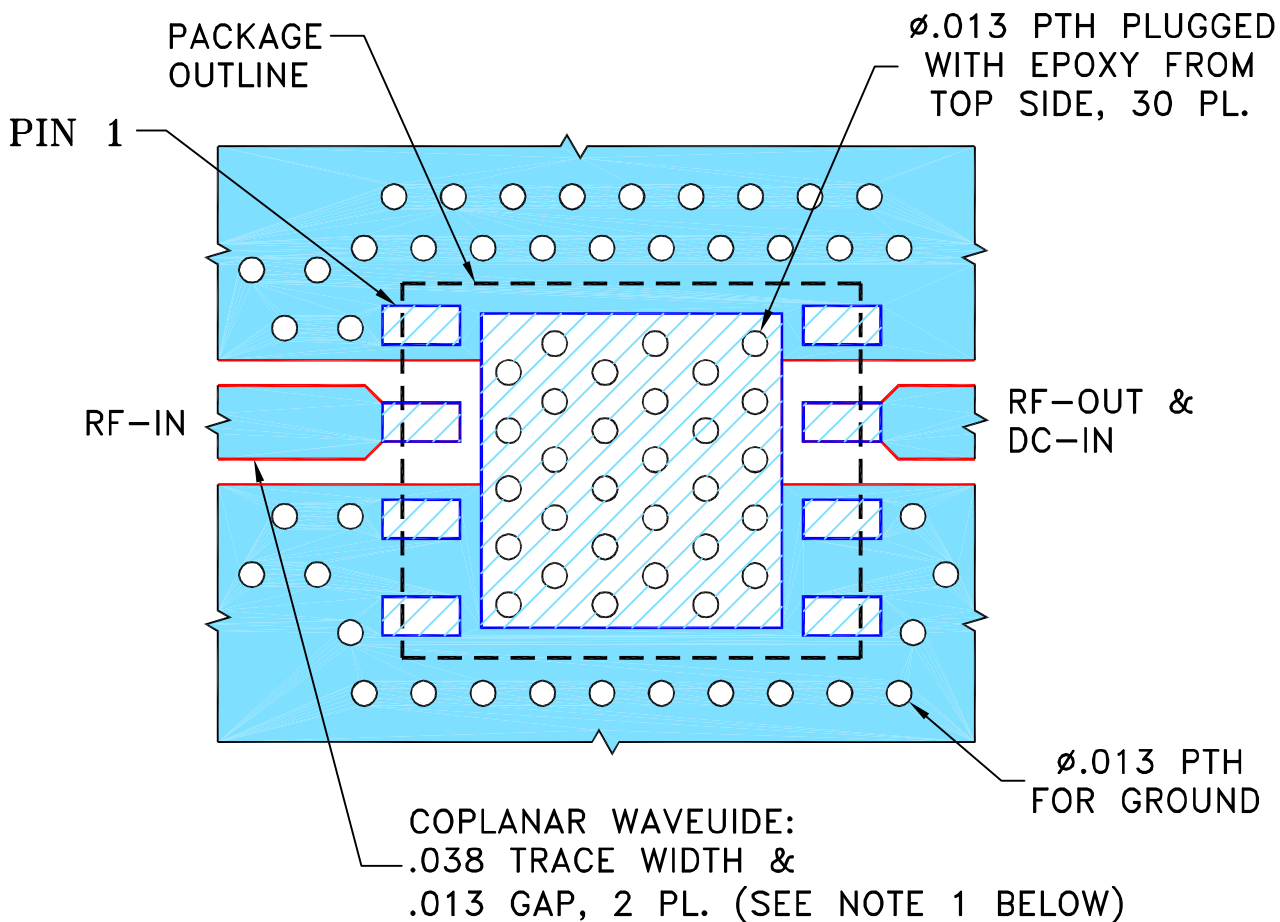

NOTES:

1. TRACE WIDTH & GAP PARAMETERS ARE SHOWN FOR ROGERS RO4350B WITH DIELECTRIC THICKNESS .020" ±.0015"; COPPER: 1/2 OZ. EACH SIDE. FOR OTHER MATERIALS TRACE WIDTH AND GAP MAY NEED TO BE MODIFIED.
2. BOTTOM SIDE OF THE PCB IS CONTINUOUS GROUND PLANE.

- DENOTES PCB COPPER LAYOUT WITH SMOBC (SOLDER MASK OVER BARE COPPER)
- DENOTES COPPER LAND PATTERN FREE OF SOLDER MASK

UNLESS OTHERWISE SPECIFIED	INITIALS	DATE
DIMENSIONS ARE IN INCHES	DRAWN CA	08/09/17
TOLERANCES ON:	CHECKED ITG	08/11/17
2 PL DECIMALS ±	APPROVED RS	08/11/17
3 PL DECIMALS ± .005		
ANGLES ±		
FRACTIONS ±		

Mini-Circuits® 13 Neptune Avenue
Brooklyn NY 11235

PL, 08AM09, DL1636, TB-962+

Mini-Circuits®
THIS DOCUMENT AND ITS CONTENTS ARE THE PROPERTY OF MINI-CIRCUITS. EXCEPT FOR USE EXPRESSLY GRANTED, IN WRITING, TO ITS VENDORS, VENDEE AND THE UNITED STATES GOVERNMENT, MINI-CIRCUITS RESERVES ALL PROPRIETARY DESIGN, USE, MANUFACTURING AND REPRODUCTION RIGHTS THERETO. THESE CONTENTS SHALL NOT BE USED, DUPLICATED OR DISCLOSED TO ANY OUTSIDE PARTY, IN WHOLE OR IN PART, WITHOUT WRITTEN PERMISSION OF MINI-CIRCUITS.

SIZE A	CODE IDENT 15542	DRAWING NO: 98-PL-522	REV: OR
FILE: 98PL522	SCALE: 10:1	SHEET: 1 OF 1	

Evaluation Board and Circuit

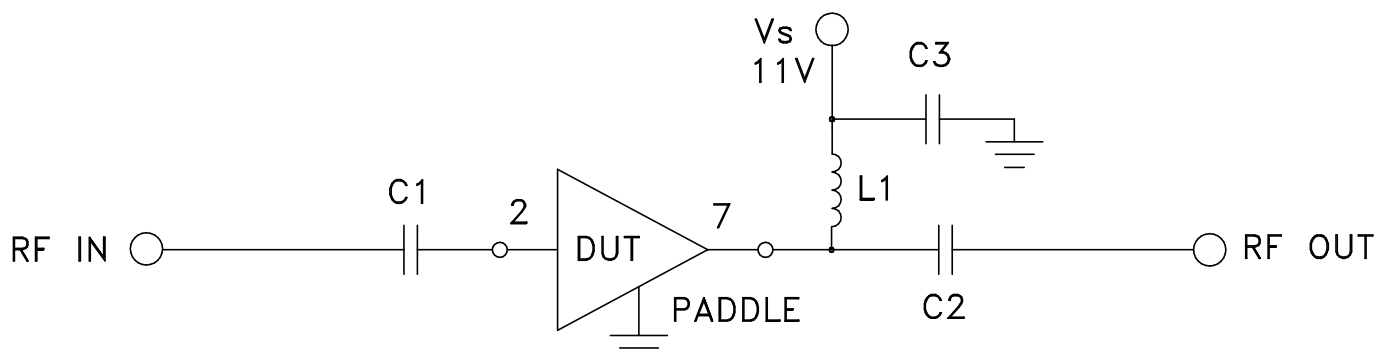
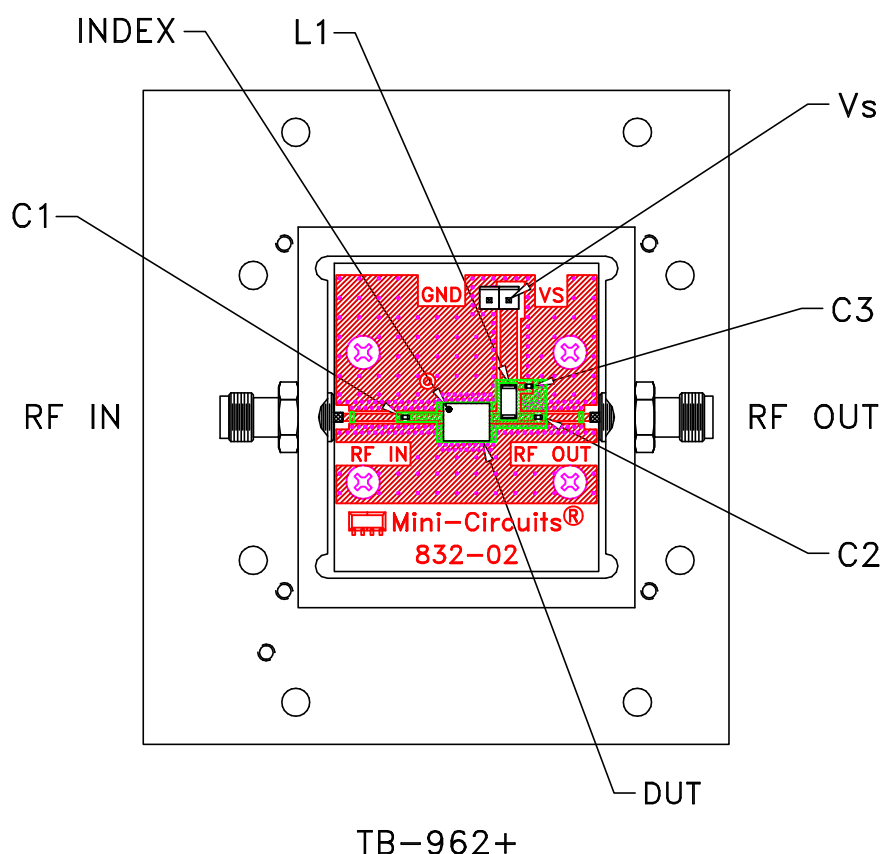

PINS 1,3-6 & 8 ARE NOT CONNECTED.

Schematic Diagram

COMPONENT	VALUE	SIZE
DUT	PHA-202+	.236X.193"
C1,C2,C3	0.01uF	0.04X0.02"
L1	5.6 uH	0.17X.0.078"

NOTES:

1. PCB material: Roger R04350B or equivalent, Dielectric constant=3.5, Thickness=.020inch
2. 50 ohm Female SMA connectors.

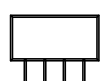

Mini-Circuits®

13 Neptune Avenue
Brooklyn NY 11235

All Mini-Circuits products are manufactured under exacting quality assurance and control standards, and are capable of meeting published specifications after being subjected to any or all of the following physical and environmental test.

Specification	Test/Inspection Condition	Reference/Spec
Operating Temperature	-40° to 85° C or -45° to 85° C or -55° to 105° C or -40° to 105° C or -40° to 95° C Ambient Environment	Individual Model Data Sheet
Storage Temperature	-55° to 100° C or -65° to 150° Ambient Environment	Individual Model Data Sheet
HTOL	1000 hours at 125°C	MIL-STD-883, Method 1005, Condition B
Thermal Shock	-55° to 100°C, 100 cycles	MIL-STD-202, Method 107, Condition A-3, except +100°C
Mechanical Shock	1.5Kg, 0.5 ms, 5 shock pulses, Y1 direction only	MIL-STD-883, Method 2002, Condition B, except Y1 direction only
Vibration (Variable Frequency)	50g peak	MIL-STD-883, Method 2007, Condition B
Autoclave	15 psig, 100% RH, 121°C, 96 hours	JESD22-A102, Condition C
HAST	130°C, 85% RH, 96 hours	JESD22-A110
Solderability	10X Magnification	J-STD-002, Para 4.2.5, Test S, 95% Coverage
Solder Reflow Heat	Sn-Pb Eutetic Process: 240°C peak Pb-Free Process: 260°C peak	J-STD-020, Table 4-1, 4-2 and 5-2; Figure 5-1
Moisture Sensitivity: Level 1	Bake at 125°C for 24 hours Soak at 85°C/85% RH for 168 hours, Reflow 3 cycles at 260°C peak	J-STD-020

All Mini-Circuits products are manufactured under exacting quality assurance and control standards, and are capable of meeting published specifications after being subjected to any or all of the following physical and environmental test.

Specification	Test/Inspection Condition	Reference/Spec
Marking Resistance to Solvents	Isopropyl alcohol + mineral spirits at 25°C; terpene defluxer at 25°C; distilled water + proylene glycol monomethyl ether + monoethanolamine at 63°C to 70°C	MIL-STD-202, Method 215