



FLAT GAIN, HIGH DYNAMIC RANGE

Monolithic Amplifier

PGA-106-75+

75Ω 0.05 to 1.5 GHz

THE BIG DEAL

- High IP3, +37 dBm typ. at 0.5 GHz
- Gain, 17.4 dB typ. at 0.5 GHz
- High P_{OUT}, P1dB +19.8 dBm typ. at 0.5 GHz
- Low Noise Figure, 3.1 dB at 0.5 GHz

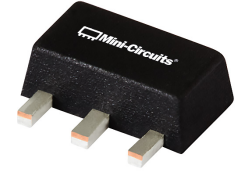

Generic photo used for illustration purposes only

CASE STYLE: DF782

APPLICATIONS

- CATV
- GPON
- MOCA
- DBS

+RoHS Compliant

The +Suffix identifies RoHS Compliance. See our website for methodologies and qualifications

PRODUCT OVERVIEW

PGA-106-75+ (RoHS compliant) is an advanced wideband amplifier fabricated using E-PHEMT technology and offers extremely high dynamic range over a broad frequency range with low noise figure and flat gain. Lead finish is SnAgNi. It has repeatable performance from lot to lot and is enclosed in a SOT-89 package for very good thermal performance.

KEY FEATURES

Feature	Advantages
Broad Band: 0.05 to 1.5 GHz	Broadband covering primary CATV applications.
High IP3 Versus DC power Consumption: +37 dBm typical at 0.5 GHz	The PGA-106-75+ matches industry leading IP3 performance relative to device size and power consumption. The combination of the design and E-PHEMPT structure provides enhanced linearity over a broad frequency range as evidence in the IP3 being typically 15-18 dB above the P 1dB point. This feature makes this amplifier ideal for use in CATV applications.
High IP2 +50-+60 dBm	Suppresses second order product on wideband applications such as CATV
Low Noise Figure: 3.1 dB at 0.5 GHz	Low noise figure performance in combination with the high output IP3 results in high dynamic range.
Excellent CSO/CTB* CSO, -56 dBc CTB, -72 dBc	Competitive performance at lower current and supply voltage.

*78 channels flat, 30 dBm/channel at output, 6 MHz channel spacing.

REV. C
ECO-011959
PGA-106-75+
MCL NY
240807





FLAT GAIN, HIGH DYNAMIC RANGE

Monolithic Amplifier

PGA-106-75+

Mini-Circuits

75Ω 0.05 to 1.5 GHz

ELECTRICAL SPECIFICATIONS¹ AT +25°C, 75Ω AND +5.0V, UNLESS NOTED OTHERWISE

Parameter	Condition (GHz)	Min.	Typ.	Max.	Units
Frequency range		0.05		1.5	GHz
Gain	0.05	–	17.8	–	dB
	0.5	–	17.4	–	
	1.0	15.5	16.9	19.5	
	1.2	–	16.7	–	
	1.5	–	16.1	–	
Input Return Loss	0.05		14.9		dB
	0.5		14.5		
	1.0		21.0		
	1.2		25.3		
Output Return Loss	0.05		21.2		dB
	0.5		16.0		
	1.0		15.5		
	1.2		14.6		
Reverse Isolation	1.0		24.4		dB
Output power @1 dB compression	0.05		+19.2		dBm
	0.5		+19.8		
	1.0		+20.1		
	1.2		+19.8		
	1.5		+19.3		
Output IP3 ²	0.05		+37.5		dBm
	0.5		+37.3		
	1.0		+36.2		
	1.2		+36.0		
	1.5		+35.0		
Output IP2 ²	0.05		+61.0		dBm
	0.5		+59.8		
	1.0		+58.4		
	1.2		+52.2		
	1.5		+59.8		
Noise Figure	0.05		3.3		dB
	0.5		3.1		
	1.0		3.3		
	1.2		3.3		
	1.5		3.7		
Device operating voltage (Vd)		+4.8	+5.0	+5.2	V
Device operating current			116	132	mA
Device current variation vs. temperature ⁴			97		μA/°C
Device current variation vs voltage			0.05		mA/mV
Thermal resistance ³			76		°C/W

1. Measured on Mini-Circuits Characterization Eval board TB-670+. See Characterization Test Circuit (Fig. 1)
 2. Output IP2 measured at sum frequency of the two tones (f meas= f1+f2).
 3. Junction to ground lead.
 4. (Current at 85°C - Current at -45°C)/130





FLAT GAIN, HIGH DYNAMIC RANGE

Monolithic Amplifier

PGA-106-75+

Mini-Circuits

75Ω 0.05 to 1.5 GHz

ABSOLUTE MAXIMUM RATINGS

Parameter	Ratings
Operating Temperature (ground lead)	-40°C to +85°C
Storage Temperature	-65°C to +150°C
Operating Current at 5.0V	170 mA
Power Dissipation	0.85 W
Input Power (CW)	+26 dBm (5 minutes) +14 dBm (continuous)
DC Voltage on Pin 3	+6 V

Permanent damage may occur if any of these limits are exceeded. Electrical maximum ratings are not intended for continuous normal operation.

HISTOGRAM

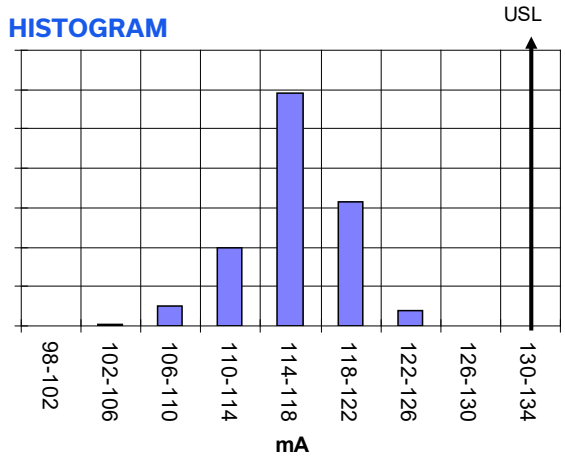

CHARACTERIZATION TEST CIRCUIT

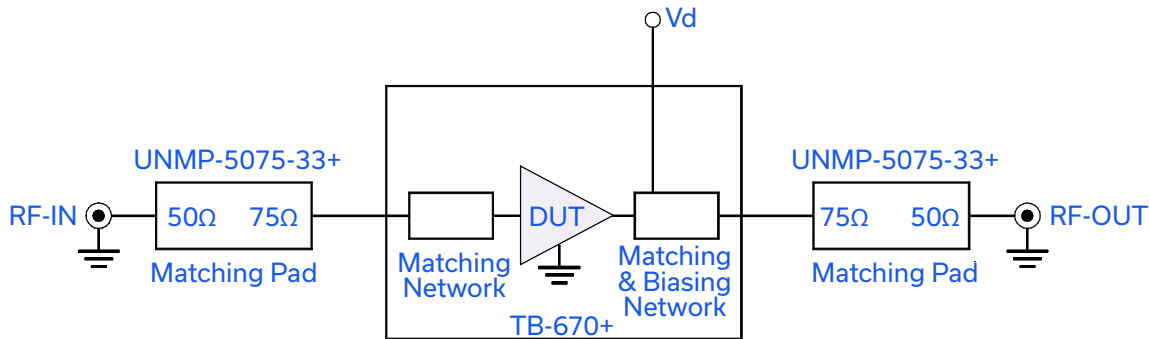

Fig 1. Block Diagram of Test Circuit used for characterization. (DUT tested on Mini-Circuits Characterization Eval board TB-670+) Gain, Return loss, Output power at 1dB compression (P1 dB), output IP3 (OIP3), output IP2 (OIP2) and noise figure measured using Agilent's N5242A PNA-X microwave network analyzer.

Conditions:

1. Gain and Return loss: $P_{IN} = -25\text{dBm}$
2. Output IP3 (OIP3): Two tones, spaced 1 MHz apart, 5 dBm/tone at output.
3. Output IP2 (OIP2): Two tones, spaced 11 MHz apart, 5 dBm/tone at output.



FLAT GAIN, HIGH DYNAMIC RANGE

Monolithic Amplifier

PGA-106-75+

Mini-Circuits

75Ω 0.05 to 1.5 GHz

RECOMMENDED APPLICATION CIRCUIT (TB-670+)

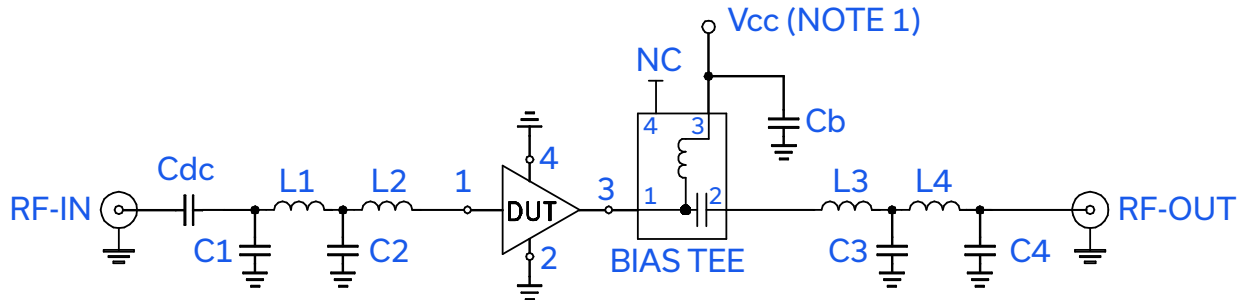
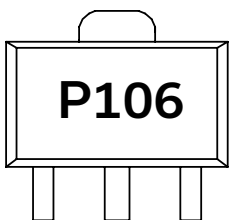

Fig 2. Evaluation board includes case, connectors, and components soldered to PCB

Component	Value
DUT	PGA-106-75+
Bias Tee	Mini-Circuits TCBT-14+
Cdc	2400 pF
Cb	0.1 μF
C1	0.5 pF
C2	1.3 pF
C3	1.2 pF
C4	0.7 pF
L1, L2, L4	7.5 nH
L3	4.7 nH

Note 1. Vcc voltage: +5±0.2V

PRODUCT MARKING



Marking may contain other features or characters for internal lot control



FLAT GAIN, HIGH DYNAMIC RANGE

Monolithic Amplifier

PGA-106-75+

Mini-Circuits

75Ω 0.05 to 1.5 GHz

ADDITIONAL DETAILED TECHNICAL INFORMATION IS AVAILABLE ON OUR DASHBOARD. [CLICK HERE](#)

Performance Data	Data Table Swept Graphs S-Parameter (S2P Files) Data Set (.zip file)
Case Style	DF782 (SOT 89) Plastic package, exposed paddle lead finish: tin-silver over nickel
Tape & Reel Standard quantities available on reel	F55 7" reels with 20, 50, 100, 200, 500 or 1K devices
Suggested Layout for PCB Design	PL-379
Evaluation Board	TB-670+
Environmental Ratings	ENV08T1

ESD RATING

Human Body Model (HBM): Class 1B (500<1000) in accordance with ANSI/ESD STM 5.1 - 2001
Machine Model (MM): Class class M1 (50V) in accordance with ANSI/ESD STM5.2-1999

MSL RATING

Moisture Sensitivity: MSL1 in accordance with IPC/JEDEC J-STD-020DD

- NOTES
- A. Performance and quality attributes and conditions not expressly stated in this specification document are intended to be excluded and do not form a part of this specification document.
 - B. Electrical specifications and performance data contained in this specification document are based on Mini-Circuit's applicable established test performance criteria and measurement instructions.
 - C. The parts covered by this specification document are subject to Mini-Circuits standard limited warranty and terms and conditions (collectively, "Standard Terms"); Purchasers of this part are entitled to the rights and benefits contained therein. For a full statement of the standard terms and the exclusive rights and remedies thereunder, please visit Mini-Circuits' website at www.minicircuits.com/terms/viewterm.html



Typical Performance Data

NOTE: Use PDF Bookmarks to view DATA at required conditions

Definitions:

Input Return Loss = -S11 (dB)

Gain(Power Gain) = S21 (dB)

Reverse Isolation = -S12 (dB)

Output Return Loss = -S22 (dB)

TEST CONDITIONS: Vd = 5.00V, Id = 108.42mA @ Temperature = +25°C

FREQ	Gain	Isolation	Input Return Loss	Output Return Loss	Stability		IP-3 Output	1dB Comp. Output	Noise Figure
					K	Measure			
(MHz)	(dB)	(dB)	(dB)	(dB)	K	Measure	(dBm)	(dBm)	(dB)
10.0	17.44	24.16	12.65	11.75	1.24	0.72	39.39	19.88	5.94
20.0	17.74	23.83	14.82	16.54	1.22	0.74	40.65	19.08	4.04
30.0	17.78	23.84	15.06	18.87	1.23	0.75	40.91	19.18	3.24
40.0	17.80	23.80	15.57	20.07	1.23	0.75	40.98	19.33	3.16
50.0	17.91	23.69	15.35	21.73	1.21	0.74	40.05	19.41	2.99
60.0	17.80	23.81	16.03	20.82	1.23	0.75	40.06	19.32	2.86
80.0	17.79	23.79	15.64	21.16	1.23	0.75	40.69	19.37	3.09
90.0	17.78	23.78	15.59	21.14	1.23	0.75	39.98	19.41	2.89
100.0	17.78	23.80	15.59	21.06	1.23	0.76	40.90	19.44	2.82
150.0	17.74	23.82	15.75	19.99	1.23	0.75	40.18	19.54	2.82
200.0	17.73	23.85	15.44	19.56	1.24	0.76	40.35	19.58	2.78
250.0	17.69	23.87	15.09	19.49	1.24	0.76	40.37	19.78	2.89
300.0	17.64	23.92	15.12	19.13	1.25	0.77	39.64	19.71	2.95
350.0	17.59	23.94	15.36	17.99	1.25	0.76	39.60	20.02	2.99
400.0	17.53	24.00	15.17	16.96	1.26	0.76	39.37	20.17	3.15
500.0	17.38	24.12	14.10	15.56	1.27	0.77	38.80	20.02	2.89
600.0	17.26	24.21	14.48	14.94	1.29	0.77	38.44	19.52	2.86
700.0	17.16	24.27	15.28	16.13	1.32	0.79	37.85	19.22	2.95
800.0	17.08	24.33	17.70	15.51	1.34	0.78	37.50	19.67	3.29
900.0	17.04	24.34	18.21	14.64	1.33	0.78	37.82	20.03	3.12
1000.0	16.99	24.37	20.94	14.91	1.35	0.78	37.29	20.29	3.03
1100.0	16.89	24.43	29.74	16.57	1.37	0.80	37.56	20.52	3.08
1200.0	16.76	24.56	30.81	14.88	1.39	0.81	36.62	19.98	3.17
1300.0	16.57	24.75	21.13	13.54	1.39	0.82	36.07	19.63	3.26
1400.0	16.37	24.93	21.59	13.06	1.43	0.83	35.86	19.64	3.46
1500.0	16.16	25.14	19.61	13.63	1.49	0.86	36.06	19.72	3.42
1600.0	15.95	25.38	18.24	12.19	1.51	0.86	35.96	19.11	3.33
1700.0	15.75	25.60	16.34	11.05	1.52	0.87	35.47	18.83	3.48
1800.0	15.62	25.75	18.08	10.89	1.58	0.85	35.39	18.86	3.61
1900.0	15.53	25.91	18.50	12.98	1.67	0.89	35.55	19.66	4.08
2000.0	15.37	26.11	13.36	15.87	1.72	0.95	35.60	20.63	3.76

Typical Performance Data

Definitions:

Input Return Loss = -S11 (dB)

Gain(Power Gain) = S21 (dB)

Reverse Isolation = -S12 (dB)

Output Return Loss = -S22 (dB)

TEST CONDITIONS: Vd = 4.75V, Id = 97.49mA @ Temperature = +25°C

FREQ	Gain	Isolation	Input Return Loss	Output Return Loss	Stability		IP-3 Output	1dB Comp. Output	Noise Figure
					K	Measure			
(MHz)	(dB)	(dB)	(dB)	(dB)	K	Measure	(dBm)	(dBm)	(dB)
10.0	17.41	24.14	12.76	11.71	1.24	0.72	40.31	19.65	5.78
20.0	17.70	23.85	14.76	16.47	1.23	0.74	39.11	18.87	3.94
30.0	17.73	23.81	15.04	18.71	1.23	0.75	39.36	18.99	3.10
40.0	17.75	23.78	15.11	19.86	1.23	0.75	39.81	19.12	3.09
50.0	17.88	23.65	16.84	21.45	1.21	0.74	40.30	19.19	2.91
60.0	17.75	23.76	15.93	20.54	1.23	0.75	41.15	19.12	2.79
80.0	17.75	23.77	15.55	20.84	1.23	0.75	40.12	19.19	3.01
90.0	17.74	23.77	15.51	20.84	1.23	0.75	40.35	19.23	2.80
100.0	17.74	23.77	15.52	20.77	1.23	0.76	40.22	19.26	2.73
150.0	17.70	23.80	15.53	19.75	1.24	0.76	40.19	19.34	2.75
200.0	17.69	23.83	15.28	19.32	1.24	0.76	39.90	19.39	2.75
250.0	17.65	23.86	15.02	19.25	1.24	0.76	39.84	19.57	2.85
300.0	17.59	23.88	15.06	18.90	1.25	0.76	39.61	19.50	2.92
350.0	17.55	23.91	15.22	17.80	1.25	0.76	39.52	19.79	2.91
400.0	17.48	23.97	15.04	16.79	1.26	0.76	39.12	19.94	3.07
500.0	17.34	24.08	13.97	15.40	1.27	0.77	38.93	19.80	2.82
600.0	17.22	24.18	14.37	14.80	1.29	0.77	38.03	19.30	2.80
700.0	17.11	24.25	15.16	15.97	1.32	0.79	38.05	19.06	2.91
800.0	17.03	24.31	17.61	15.37	1.34	0.78	37.78	19.48	3.40
900.0	17.00	24.30	18.07	14.48	1.33	0.78	37.99	19.82	3.09
1000.0	16.95	24.33	20.58	14.75	1.35	0.78	37.22	20.04	3.01
1100.0	16.86	24.39	29.44	16.39	1.37	0.80	37.31	20.28	3.03
1200.0	16.72	24.51	31.72	14.75	1.38	0.80	36.71	19.79	3.10
1300.0	16.53	24.70	21.26	13.40	1.39	0.82	36.44	19.40	3.20
1400.0	16.33	24.88	21.70	12.93	1.43	0.83	36.18	19.34	3.39
1500.0	16.13	25.09	19.71	13.48	1.48	0.85	36.38	19.41	3.38
1600.0	15.91	25.32	18.34	12.07	1.50	0.86	36.44	18.78	3.28
1700.0	15.72	25.55	16.48	10.94	1.51	0.86	36.17	18.52	3.44
1800.0	15.59	25.71	18.23	10.79	1.58	0.85	36.14	18.57	3.53
1900.0	15.50	25.84	18.73	12.87	1.66	0.88	36.08	19.38	4.01
2000.0	15.34	26.06	13.42	15.63	1.71	0.95	35.80	20.36	3.74

Typical Performance Data

Definitions:

Input Return Loss = -S11 (dB)

Gain(Power Gain) = S21 (dB)

Reverse Isolation = -S12 (dB)

Output Return Loss = -S22 (dB)

TEST CONDITIONS: Vd = 5.25V, Id = 119.54mA @ Temperature = +25°C

FREQ	Gain	Isolation	Input Return Loss	Output Return Loss	Stability		IP-3 Output	1dB Comp. Output	Noise Figure
					K	Measure			
(MHz)	(dB)	(dB)	(dB)	(dB)	K	Measure	(dBm)	(dBm)	(dB)
10.0	17.51	24.04	14.13	11.75	1.23	0.70	39.60	20.08	6.06
20.0	17.78	23.88	15.00	16.62	1.23	0.74	38.59	19.17	4.15
30.0	17.81	23.83	15.18	19.00	1.23	0.75	39.43	19.26	3.28
40.0	17.83	23.82	15.48	20.23	1.23	0.75	39.35	19.43	3.25
50.0	17.96	23.80	17.02	21.96	1.22	0.74	38.81	19.55	3.06
60.0	17.83	23.76	15.89	20.97	1.22	0.75	39.88	19.41	2.96
80.0	17.82	23.80	15.79	21.33	1.23	0.75	38.75	19.46	3.18
90.0	17.81	23.80	15.75	21.33	1.23	0.75	38.41	19.50	2.94
100.0	17.81	23.81	15.76	21.25	1.23	0.75	39.21	19.52	2.85
150.0	17.77	23.87	15.94	20.21	1.24	0.75	38.57	19.62	2.84
200.0	17.76	23.87	15.53	19.73	1.24	0.76	38.43	19.69	2.86
250.0	17.72	23.89	15.20	19.67	1.24	0.76	37.94	19.87	2.96
300.0	17.67	23.91	15.25	19.30	1.24	0.76	38.64	19.81	3.00
350.0	17.62	23.96	15.41	18.14	1.25	0.76	38.63	20.13	3.04
400.0	17.56	24.02	15.31	17.10	1.26	0.76	38.44	20.29	3.17
500.0	17.41	24.13	14.18	15.67	1.27	0.77	38.32	20.14	2.92
600.0	17.30	24.23	14.55	15.06	1.29	0.77	37.23	19.62	2.89
700.0	17.19	24.29	15.40	16.27	1.32	0.79	36.77	19.27	2.98
800.0	17.11	24.33	17.83	15.66	1.33	0.78	36.69	19.74	3.38
900.0	17.07	24.37	18.35	14.76	1.33	0.78	37.05	20.14	3.15
1000.0	17.03	24.39	20.84	15.06	1.35	0.78	36.83	20.44	3.09
1100.0	16.93	24.46	30.30	16.79	1.37	0.80	36.95	20.65	3.15
1200.0	16.79	24.59	30.57	15.09	1.39	0.81	35.91	20.04	3.16
1300.0	16.60	24.78	20.98	13.70	1.40	0.83	35.41	19.74	3.33
1400.0	16.41	24.97	21.43	13.22	1.44	0.83	35.20	19.80	3.49
1500.0	16.20	25.18	19.45	13.80	1.49	0.86	35.39	19.90	3.46
1600.0	15.99	25.42	18.18	12.36	1.51	0.86	35.23	19.36	3.39
1700.0	15.80	25.64	16.27	11.18	1.52	0.87	34.81	19.09	3.53
1800.0	15.66	25.81	17.99	11.00	1.59	0.85	34.66	19.09	3.64
1900.0	15.57	25.97	18.36	13.10	1.68	0.89	34.79	19.86	4.11
2000.0	15.41	26.17	13.34	16.14	1.72	0.95	34.97	20.83	3.78

Typical Performance Data

Definitions:

Input Return Loss = -S11 (dB)

Gain(Power Gain) = S21 (dB)

Reverse Isolation = -S12 (dB)

Output Return Loss = -S22 (dB)

TEST CONDITIONS: Vd = 5.00V, Id = 95.93mA @ Temperature = -45°C

FREQ	Gain	Isolation	Input Return Loss	Output Return Loss	Stability		IP-3 Output	1dB Comp. Output	Noise Figure
					K	Measure			
(MHz)	(dB)	(dB)	(dB)	(dB)	K	Measure	(dBm)	(dBm)	(dB)
10.0	17.29	24.01	12.03	10.76	1.23	0.70	39.32	20.28	7.26
20.0	17.62	23.69	13.91	15.33	1.22	0.73	46.84	19.40	4.07
30.0	17.66	23.67	14.28	17.33	1.22	0.74	43.88	19.46	2.66
40.0	17.67	23.65	14.26	18.14	1.22	0.75	42.35	19.63	2.30
50.0	17.79	23.50	15.32	19.14	1.20	0.73	45.45	19.76	2.04
60.0	17.66	23.66	14.84	18.19	1.22	0.74	43.58	19.65	1.87
80.0	17.66	23.65	14.18	18.03	1.22	0.75	47.47	19.74	2.10
90.0	17.65	23.63	14.26	17.96	1.22	0.74	45.56	19.78	1.86
100.0	17.65	23.64	14.23	17.93	1.22	0.74	45.30	19.81	1.75
150.0	17.63	23.69	14.89	18.30	1.23	0.75	46.42	19.88	1.82
200.0	17.63	23.65	15.31	19.04	1.23	0.75	43.28	19.93	1.89
250.0	17.61	23.66	14.92	18.25	1.23	0.75	42.18	20.13	1.96
300.0	17.53	23.73	14.78	17.26	1.24	0.75	42.18	20.06	2.04
350.0	17.52	23.72	14.69	16.31	1.23	0.75	41.76	20.35	2.04
400.0	17.46	23.79	14.32	15.45	1.24	0.75	41.49	20.51	2.17
500.0	17.34	23.86	12.69	13.72	1.24	0.75	40.77	20.37	1.90
600.0	17.25	23.93	13.53	14.11	1.26	0.75	39.48	19.90	1.88
700.0	17.17	23.97	14.91	15.44	1.29	0.77	38.47	19.66	1.96
800.0	17.12	23.98	18.04	15.21	1.30	0.76	37.98	20.09	2.47
900.0	17.13	23.97	17.22	13.08	1.27	0.75	38.30	20.47	2.11
1000.0	17.08	23.99	18.60	13.40	1.29	0.75	37.69	20.63	1.97
1100.0	16.97	24.05	24.64	15.67	1.32	0.77	38.02	20.86	2.04
1200.0	16.85	24.18	33.42	14.95	1.34	0.78	36.74	20.45	2.11
1300.0	16.66	24.35	19.76	12.36	1.31	0.80	35.71	20.07	2.18
1400.0	16.47	24.53	19.79	11.53	1.34	0.80	35.39	19.97	2.35
1500.0	16.30	24.70	21.39	12.01	1.40	0.81	35.67	20.19	2.30
1600.0	16.13	24.90	21.09	12.57	1.45	0.83	35.47	19.56	2.17
1700.0	15.99	25.06	17.45	11.91	1.45	0.85	35.00	19.18	2.36
1800.0	15.91	25.17	17.18	10.92	1.45	0.84	34.92	19.17	2.41
1900.0	15.82	25.30	16.53	11.11	1.47	0.86	35.16	20.00	3.00
2000.0	15.65	25.54	14.49	13.05	1.55	0.91	35.13	21.03	2.58

Typical Performance Data

Definitions:

Input Return Loss = -S11 (dB)

Gain(Power Gain) = S21 (dB)

Reverse Isolation = -S12 (dB)

Output Return Loss = -S22 (dB)

TEST CONDITIONS: Vd = 4.75V, Id = 84.64mA @ Temperature = -45°C

FREQ	Gain	Isolation	Input Return Loss	Output Return Loss	Stability		IP-3 Output	1dB Comp. Output	Noise Figure
					K	Measure			
(MHz)	(dB)	(dB)	(dB)	(dB)	K	Measure	(dBm)	(dBm)	(dB)
10.0	17.21	24.04	11.89	10.74	1.23	0.71	39.08	19.81	6.75
20.0	17.52	23.62	13.77	15.09	1.22	0.73	43.28	19.04	3.74
30.0	17.56	23.61	13.83	16.94	1.22	0.74	44.55	19.10	2.44
40.0	17.58	23.59	14.10	17.66	1.22	0.75	43.56	19.25	2.18
50.0	17.70	23.57	14.86	18.62	1.21	0.74	45.08	19.38	1.96
60.0	17.57	23.62	14.48	17.67	1.22	0.75	46.74	19.30	1.77
80.0	17.56	23.58	14.04	17.53	1.22	0.74	43.65	19.38	2.04
90.0	17.56	23.57	14.05	17.46	1.22	0.74	43.29	19.43	1.83
100.0	17.56	23.58	13.97	17.44	1.22	0.74	44.61	19.46	1.77
150.0	17.54	23.60	14.70	17.82	1.23	0.75	43.81	19.53	1.81
200.0	17.54	23.60	15.10	18.50	1.23	0.75	42.55	19.56	1.81
250.0	17.51	23.62	14.58	17.76	1.23	0.75	41.09	19.73	1.96
300.0	17.44	23.68	14.56	16.87	1.24	0.75	41.48	19.68	2.02
350.0	17.43	23.67	14.44	15.93	1.23	0.75	40.72	19.95	1.99
400.0	17.37	23.73	14.07	15.08	1.24	0.75	40.97	20.08	2.16
500.0	17.25	23.81	12.57	13.44	1.24	0.75	39.80	19.95	1.86
600.0	17.16	23.87	13.30	13.81	1.26	0.75	38.98	19.52	1.84
700.0	17.08	23.92	14.66	15.12	1.29	0.77	38.05	19.34	1.86
800.0	17.03	23.93	17.59	14.91	1.30	0.76	37.68	19.74	2.44
900.0	17.04	23.90	16.96	12.83	1.27	0.75	38.22	20.09	2.07
1000.0	16.99	23.92	18.19	13.14	1.29	0.74	37.20	20.19	1.98
1100.0	16.89	24.00	23.95	15.36	1.32	0.77	37.29	20.42	2.05
1200.0	16.77	24.11	35.91	14.78	1.34	0.78	36.32	20.06	2.09
1300.0	16.58	24.28	19.86	12.20	1.31	0.80	35.55	19.64	2.15
1400.0	16.39	24.47	19.77	11.37	1.33	0.80	35.21	19.47	2.33
1500.0	16.22	24.63	21.41	11.82	1.39	0.81	35.49	19.68	2.27
1600.0	16.05	24.82	21.40	12.40	1.45	0.83	35.36	19.11	2.14
1700.0	15.92	24.98	17.63	11.75	1.44	0.85	34.85	18.77	2.29
1800.0	15.83	25.09	17.29	10.76	1.44	0.84	34.65	18.78	2.38
1900.0	15.75	25.22	16.59	10.93	1.46	0.85	34.89	19.62	2.97
2000.0	15.58	25.43	14.60	12.84	1.54	0.90	34.84	20.57	2.56

Typical Performance Data

Definitions:

Input Return Loss = -S11 (dB)

Gain(Power Gain) = S21 (dB)

Reverse Isolation = -S12 (dB)

Output Return Loss = -S22 (dB)

TEST CONDITIONS: Vd = 5.25V, Id = 106.97mA @ Temperature = -45°C

FREQ	Gain	Isolation	Input Return Loss	Output Return Loss	Stability		IP-3 Output	1dB Comp. Output	Noise Figure
					K	Measure			
(MHz)	(dB)	(dB)	(dB)	(dB)	K	Measure	(dBm)	(dBm)	(dB)
10.0	17.38	23.92	12.48	10.86	1.21	0.69	42.05	20.61	7.71
20.0	17.69	23.73	14.00	15.55	1.21	0.73	49.08	19.68	4.43
30.0	17.72	23.70	14.34	17.61	1.22	0.74	45.60	19.73	2.83
40.0	17.74	23.70	14.51	18.46	1.22	0.74	43.30	19.89	2.48
50.0	17.86	23.74	14.56	19.60	1.21	0.75	44.06	19.99	2.12
60.0	17.73	23.71	14.41	18.54	1.22	0.75	45.92	19.90	1.94
80.0	17.73	23.68	14.37	18.39	1.22	0.74	44.69	19.97	2.13
90.0	17.72	23.68	14.44	18.32	1.22	0.74	44.89	20.01	1.88
100.0	17.72	23.68	14.44	18.31	1.22	0.74	44.45	20.05	1.77
150.0	17.70	23.71	15.01	18.73	1.23	0.75	46.43	20.13	1.80
200.0	17.70	23.70	15.44	19.46	1.23	0.75	42.70	20.18	1.83
250.0	17.68	23.71	15.17	18.63	1.23	0.75	42.62	20.39	1.92
300.0	17.60	23.77	15.00	17.65	1.23	0.75	42.07	20.32	2.02
350.0	17.59	23.76	14.95	16.60	1.23	0.75	41.39	20.63	2.03
400.0	17.53	23.82	14.45	15.65	1.23	0.75	41.24	20.79	2.14
500.0	17.41	23.91	12.80	13.95	1.24	0.75	40.79	20.66	1.89
600.0	17.32	23.97	13.59	14.32	1.26	0.75	39.44	20.16	1.83
700.0	17.24	24.01	15.15	15.72	1.28	0.77	38.31	19.89	1.92
800.0	17.19	24.03	18.23	15.45	1.29	0.76	38.05	20.33	2.45
900.0	17.20	24.01	17.44	13.25	1.27	0.75	38.32	20.75	2.09
1000.0	17.15	24.03	18.87	13.61	1.29	0.75	38.07	20.95	2.03
1100.0	17.04	24.10	25.38	15.91	1.32	0.78	37.66	21.19	2.03
1200.0	16.92	24.22	32.18	15.18	1.34	0.79	36.68	20.72	2.09
1300.0	16.72	24.39	19.46	12.44	1.31	0.80	35.96	20.36	2.16
1400.0	16.53	24.59	19.69	11.69	1.34	0.81	35.53	20.33	2.36
1500.0	16.36	24.75	21.22	12.14	1.39	0.82	35.87	20.57	2.36
1600.0	16.20	24.94	21.13	12.79	1.45	0.84	35.60	19.90	2.20
1700.0	16.06	25.11	17.50	12.09	1.45	0.85	35.18	19.52	2.35
1800.0	15.98	25.22	17.12	11.07	1.45	0.85	34.84	19.49	2.44
1900.0	15.89	25.35	16.31	11.23	1.47	0.86	35.06	20.32	2.99
2000.0	15.71	25.59	14.33	13.21	1.55	0.91	35.25	21.37	2.61

Typical Performance Data

Definitions:

Input Return Loss = -S11 (dB)

Gain(Power Gain) = S21 (dB)

Reverse Isolation = -S12 (dB)

Output Return Loss = -S22 (dB)

TEST CONDITIONS: Vd = 5.00V, Id = 114.60mA @ Temperature = +85°C

FREQ	Gain	Isolation	Input Return Loss	Output Return Loss	Stability		IP-3 Output	1dB Comp. Output	Noise Figure
					K	Measure			
(MHz)	(dB)	(dB)	(dB)	(dB)	K	Measure	(dBm)	(dBm)	(dB)
10.0	17.33	23.94	13.12	12.08	1.24	0.72	35.46	19.42	6.49
20.0	17.59	23.80	14.80	16.54	1.23	0.75	33.61	18.53	4.60
30.0	17.63	23.77	15.28	18.59	1.23	0.75	33.82	18.59	3.85
40.0	17.65	23.76	15.50	19.72	1.23	0.76	34.34	18.78	3.78
50.0	17.77	23.62	16.27	21.46	1.22	0.74	34.34	18.89	3.68
60.0	17.65	23.74	16.53	20.79	1.24	0.75	34.01	18.73	3.55
80.0	17.64	23.73	16.07	21.59	1.24	0.76	33.77	18.80	3.79
90.0	17.63	23.73	16.03	21.68	1.24	0.76	33.62	18.83	3.59
100.0	17.63	23.76	15.95	21.60	1.24	0.76	33.81	18.86	3.54
150.0	17.58	23.82	15.67	19.58	1.25	0.76	34.07	18.98	3.62
200.0	17.55	23.82	14.85	18.57	1.25	0.76	34.01	19.04	3.64
250.0	17.51	23.85	14.70	19.18	1.25	0.77	34.02	19.21	3.76
300.0	17.46	23.88	15.00	19.65	1.26	0.78	34.12	19.16	3.81
350.0	17.39	23.95	15.42	18.38	1.27	0.78	34.43	19.46	3.85
400.0	17.31	24.02	15.38	17.13	1.28	0.78	34.49	19.61	3.97
500.0	17.16	24.14	14.66	16.19	1.30	0.79	34.41	19.42	3.73
600.0	17.01	24.27	14.54	14.51	1.32	0.78	33.56	18.88	3.70
700.0	16.88	24.36	14.84	15.64	1.35	0.80	32.94	18.54	3.84
800.0	16.79	24.43	17.42	15.55	1.38	0.80	33.20	19.01	4.34
900.0	16.73	24.47	18.72	16.50	1.39	0.81	33.70	19.39	4.01
1000.0	16.70	24.50	22.08	14.93	1.39	0.80	34.16	19.69	3.95
1100.0	16.63	24.55	26.88	15.34	1.41	0.81	34.64	19.91	3.96
1200.0	16.48	24.69	30.11	14.48	1.43	0.82	33.93	19.30	4.09
1300.0	16.27	24.91	22.18	15.42	1.48	0.85	33.57	19.00	4.17
1400.0	16.06	25.13	22.46	14.29	1.52	0.85	33.37	19.02	4.39
1500.0	15.83	25.37	18.80	13.62	1.56	0.87	33.65	19.07	4.37
1600.0	15.58	25.66	16.25	11.05	1.55	0.87	33.64	18.63	4.29
1700.0	15.34	25.92	14.96	10.60	1.60	0.88	33.14	18.38	4.48
1800.0	15.18	26.15	17.82	10.95	1.73	0.86	32.95	18.41	4.61
1900.0	15.08	26.31	20.13	13.98	1.85	0.90	33.21	19.17	5.01
2000.0	14.94	26.50	12.40	16.64	1.85	0.98	33.76	20.10	4.76

Typical Performance Data

Definitions:

Input Return Loss = -S11 (dB)

Gain(Power Gain) = S21 (dB)

Reverse Isolation = -S12 (dB)

Output Return Loss = -S22 (dB)

TEST CONDITIONS: Vd = 4.75V, Id = 103.87mA @ Temperature = +85°C

FREQ	Gain	Isolation	Input Return Loss	Output Return Loss	Stability		IP-3 Output	1dB Comp. Output	Noise Figure
					K	Measure			
(MHz)	(dB)	(dB)	(dB)	(dB)	K	Measure	(dBm)	(dBm)	(dB)
10.0	17.28	23.99	13.26	12.07	1.24	0.73	35.96	19.30	6.34
20.0	17.56	23.80	14.89	16.47	1.24	0.75	35.26	18.42	4.48
30.0	17.60	23.77	15.08	18.47	1.24	0.76	35.84	18.49	3.67
40.0	17.62	23.72	15.41	19.58	1.23	0.76	36.40	18.67	3.69
50.0	17.74	23.74	15.95	21.33	1.23	0.75	36.11	18.77	3.53
60.0	17.62	23.66	16.37	20.62	1.23	0.75	35.59	18.65	3.45
80.0	17.61	23.72	15.87	21.39	1.24	0.76	35.89	18.72	3.68
90.0	17.61	23.72	15.93	21.49	1.24	0.76	35.63	18.75	3.52
100.0	17.60	23.72	15.85	21.40	1.24	0.76	35.61	18.78	3.46
150.0	17.55	23.77	15.52	19.39	1.24	0.76	35.89	18.88	3.54
200.0	17.53	23.81	14.76	18.44	1.25	0.76	35.89	18.93	3.55
250.0	17.48	23.84	14.57	19.03	1.25	0.77	35.67	19.10	3.69
300.0	17.43	23.87	14.96	19.49	1.26	0.78	35.95	19.06	3.72
350.0	17.36	23.93	15.40	18.27	1.27	0.78	36.01	19.34	3.77
400.0	17.29	23.99	15.22	17.06	1.28	0.78	36.17	19.48	3.91
500.0	17.13	24.12	14.51	16.08	1.30	0.79	35.84	19.30	3.67
600.0	16.98	24.26	14.45	14.39	1.32	0.78	35.45	18.78	3.66
700.0	16.85	24.34	14.69	15.52	1.35	0.80	34.75	18.49	3.76
800.0	16.76	24.41	17.19	15.48	1.38	0.80	34.89	18.95	4.04
900.0	16.71	24.45	18.65	16.42	1.39	0.81	35.10	19.30	3.94
1000.0	16.67	24.47	22.02	14.76	1.39	0.80	35.28	19.55	3.88
1100.0	16.60	24.52	26.65	15.16	1.40	0.81	35.66	19.78	3.93
1200.0	16.45	24.67	30.23	14.35	1.43	0.82	35.17	19.21	3.99
1300.0	16.25	24.88	22.39	15.32	1.48	0.85	34.75	18.86	4.10
1400.0	16.03	25.09	22.59	14.15	1.52	0.85	34.57	18.83	4.35
1500.0	15.80	25.33	18.90	13.47	1.56	0.87	34.70	18.85	4.32
1600.0	15.55	25.63	16.37	10.93	1.55	0.87	34.66	18.37	4.24
1700.0	15.31	25.89	15.03	10.55	1.60	0.88	34.36	18.13	4.43
1800.0	15.15	26.10	17.88	10.92	1.72	0.86	34.19	18.17	4.53
1900.0	15.05	26.27	20.36	13.93	1.85	0.90	34.22	18.95	4.98
2000.0	14.91	26.43	12.51	16.37	1.84	0.98	34.60	19.90	4.72

Typical Performance Data

Definitions:

Input Return Loss = -S11 (dB)

Gain(Power Gain) = S21 (dB)

Reverse Isolation = -S12 (dB)

Output Return Loss = -S22 (dB)

TEST CONDITIONS: Vd = 5.25V, Id = 125.28mA @ Temperature = +85°C

FREQ	Gain	Isolation	Input Return Loss	Output Return Loss	Stability		IP-3 Output	1dB Comp. Output	Noise Figure
					K	Measure			
(MHz)	(dB)	(dB)	(dB)	(dB)	K	Measure	(dBm)	(dBm)	(dB)
10.0	17.34	24.02	14.13	12.14	1.25	0.72	31.93	19.37	6.59
20.0	17.57	23.80	14.92	16.59	1.24	0.75	31.24	18.47	4.64
30.0	17.61	23.78	15.32	18.64	1.24	0.76	31.61	18.54	3.85
40.0	17.63	23.77	15.57	19.81	1.24	0.76	31.84	18.74	3.82
50.0	17.76	23.61	17.24	21.53	1.22	0.74	31.67	18.85	3.66
60.0	17.63	23.76	15.88	20.92	1.24	0.76	31.46	18.69	3.55
80.0	17.62	23.75	16.14	21.73	1.24	0.76	31.18	18.69	3.56
90.0	17.61	23.74	16.11	21.82	1.24	0.76	31.06	18.71	3.47
100.0	17.61	23.76	16.09	21.73	1.24	0.76	31.21	18.74	3.47
150.0	17.56	23.80	15.61	19.64	1.25	0.76	31.38	18.92	3.57
200.0	17.53	23.85	14.91	18.69	1.25	0.77	31.52	18.95	3.59
250.0	17.49	23.87	14.75	19.30	1.25	0.77	31.55	19.15	3.67
300.0	17.44	23.90	15.17	19.77	1.26	0.78	31.73	19.08	3.73
350.0	17.37	23.96	15.46	18.56	1.28	0.78	32.07	19.41	3.76
400.0	17.29	24.02	15.40	17.33	1.28	0.78	32.18	19.54	3.98
500.0	17.14	24.16	14.60	16.30	1.30	0.79	31.93	19.32	3.80
600.0	16.99	24.30	14.58	14.56	1.33	0.79	31.11	18.70	3.71
700.0	16.86	24.38	14.83	15.73	1.36	0.80	30.56	18.36	3.83
800.0	16.77	24.45	17.30	15.73	1.38	0.80	30.76	18.81	4.11
900.0	16.72	24.51	18.68	16.74	1.40	0.82	31.37	19.28	4.01
1000.0	16.69	24.53	22.07	15.01	1.40	0.80	32.17	19.66	3.92
1100.0	16.61	24.57	26.31	15.48	1.41	0.81	32.59	19.89	3.99
1200.0	16.46	24.74	29.85	14.66	1.44	0.82	31.89	19.27	4.09
1300.0	16.26	24.94	21.88	15.74	1.49	0.85	31.48	19.00	4.19
1400.0	16.04	25.17	22.16	14.48	1.53	0.86	31.31	19.04	4.36
1500.0	15.81	25.42	18.69	13.79	1.57	0.88	31.59	19.17	4.40
1600.0	15.56	25.72	16.17	11.15	1.56	0.88	31.63	18.80	4.36
1700.0	15.33	25.98	14.75	10.75	1.62	0.88	31.18	18.53	4.52
1800.0	15.16	26.21	17.55	11.07	1.74	0.87	30.97	18.52	4.63
1900.0	15.06	26.38	19.85	14.12	1.87	0.91	31.27	19.27	5.11
2000.0	14.92	26.58	12.32	16.89	1.87	0.98	32.17	20.18	4.86

Typical Performance Curves

GAIN vs. FREQUENCY & TEMPERATURE
INPUT POWER = -25dBm, Vd = 5V

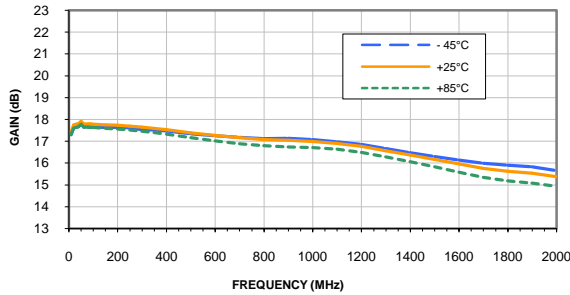

GAIN vs. FREQUENCY & DEVICE VOLTAGE
INPUT POWER = -25dBm, Temperature = +25°C

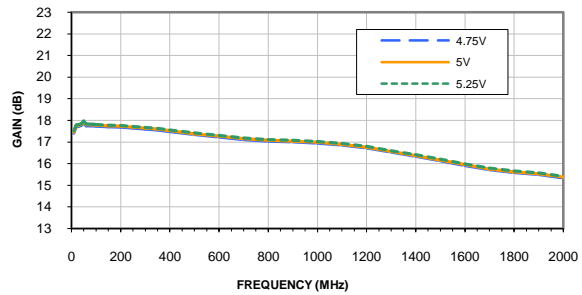

ISOLATION vs. FREQUENCY & TEMPERATURE
INPUT POWER = -25dBm, Vd = 5V

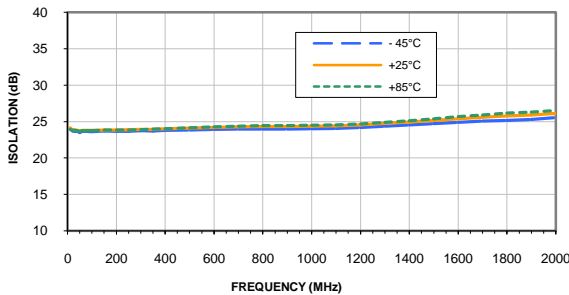

ISOLATION vs. FREQUENCY & DEVICE VOLTAGE
INPUT POWER = -25dBm, Temperature = +25°C

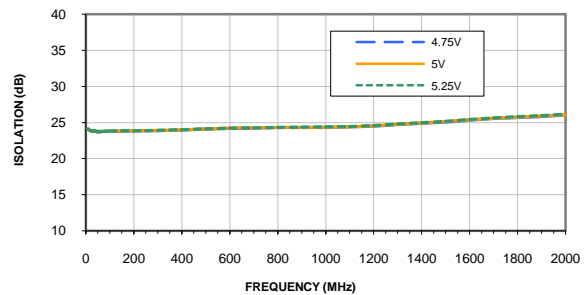

INPUT RETURN LOSS vs. FREQUENCY & TEMPERATURE
INPUT POWER = -25dBm, Vd = 5V

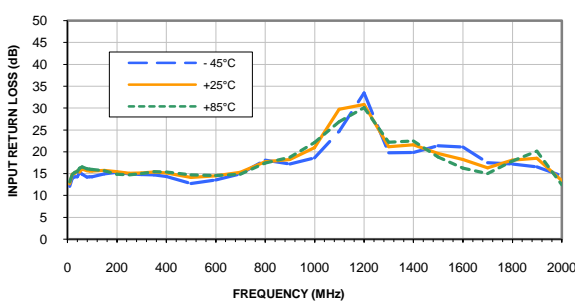

INPUT RETURN LOSS vs. FREQUENCY & DEVICE VOLTAGE
INPUT POWER = -25dBm, Temperature = +25°C

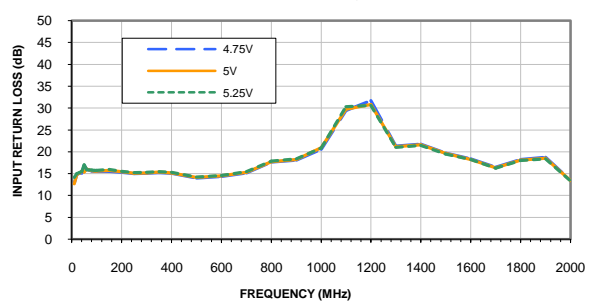

OUTPUT RETURN LOSS vs. FREQUENCY & TEMPERATURE
INPUT POWER = -25dBm, Vd = 5V

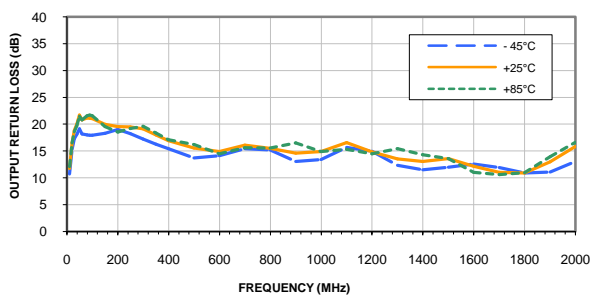

OUTPUT RETURN LOSS vs. FREQUENCY & DEVICE VOLTAGE
INPUT POWER = -25dBm, Temperature = +25°C

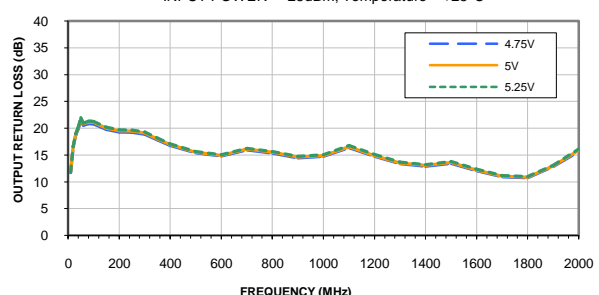

Typical Performance Curves

OUTPUT IP3 vs. FREQUENCY & TEMPERATURE
OUTPUT POWER = 5 dBm/tone, Vd = 5V

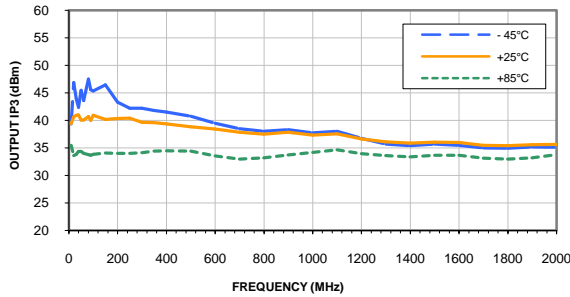

OUTPUT IP3 vs. FREQUENCY & DEVICE VOLTAGE
OUTPUT POWER = 5 dBm/tone, Temperature = +25°C

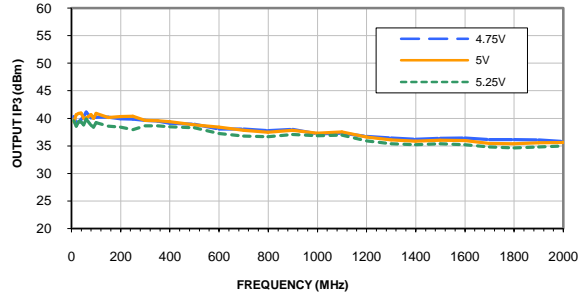

P1dB vs. FREQUENCY & TEMPERATURE
Vd = 5V

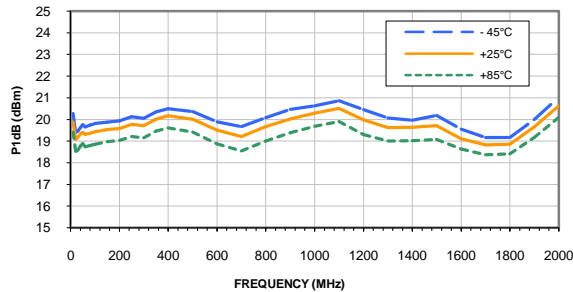

P1dB vs. FREQUENCY & DEVICE VOLTAGE
Temperature = +25°C

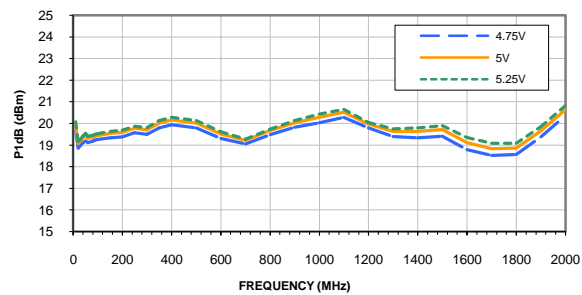

NOISE FIGURE vs. FREQUENCY & TEMPERATURE
Vd = 5V

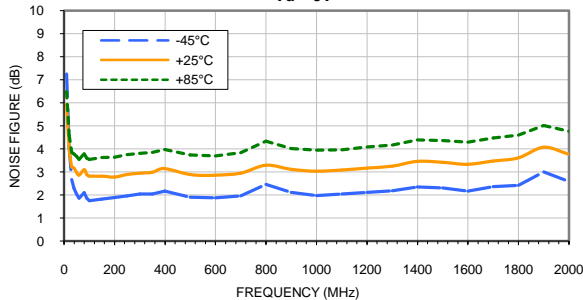

NOISE FIGURE vs. FREQUENCY & DEVICE VOLTAGE
Temperature = +25°C

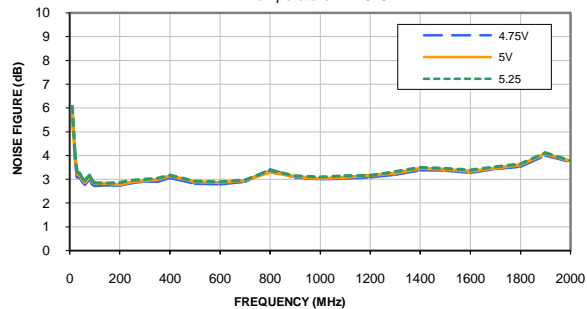

GAIN VARIATION vs. FREQUENCY & TEMPERATURE
INPUT POWER = -25dBm, Vd = 5V

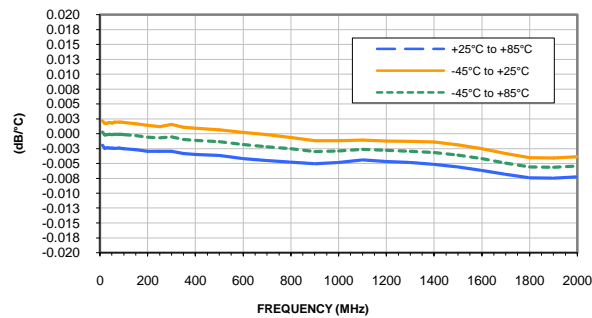

Outline Dimensions

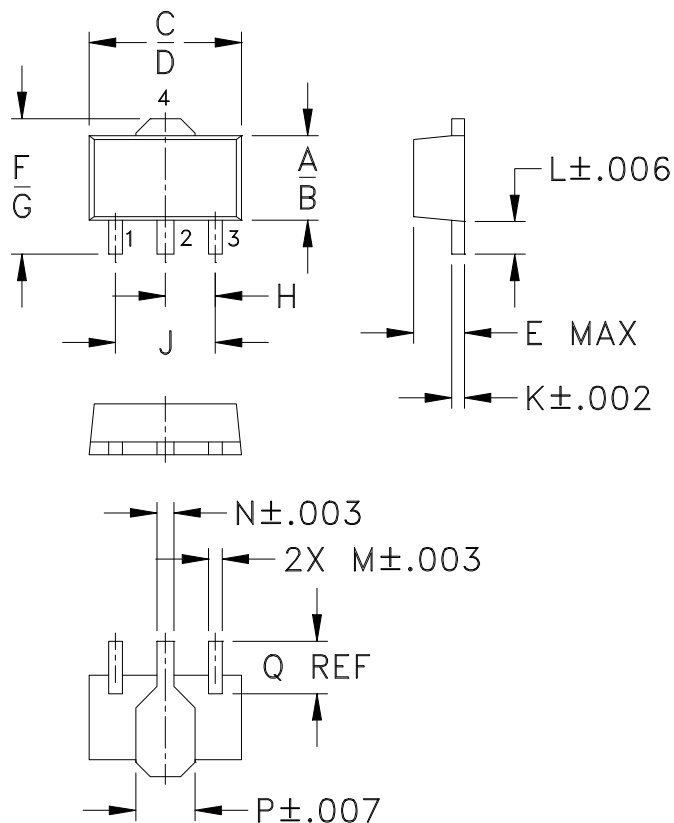

PCB Land Pattern

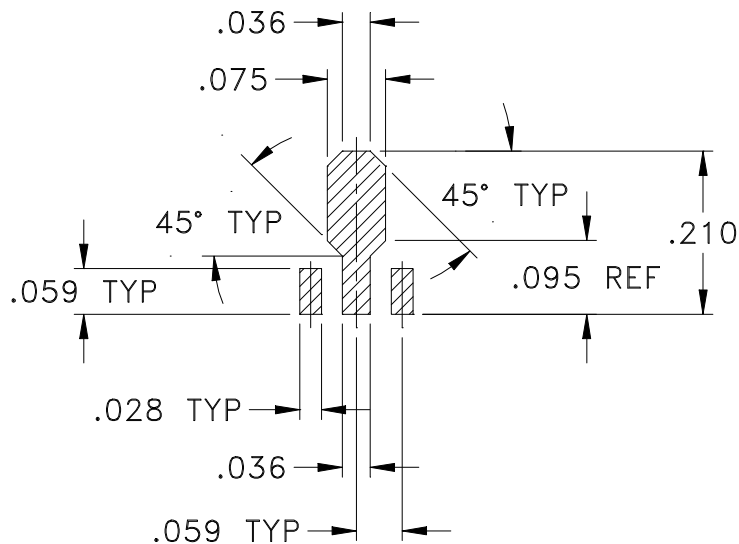

Suggested Layout,
Tolerance to be within $\pm .002$

CASE #	A	B	C	D	E	F	G	H	J	K	L	M
DF782	.102 (2.59)	.090 (2.29)	.181 (4.60)	.173 (4.39)	.063 (1.60)	.167 (4.24)	.155 (3.94)	.059 (1.50)	.118 (3.00)	.015 (0.38)	.041 (1.04)	.016 (0.41)

CASE #	N	P	Q	WT. GRAM
DF782	.019 (0.48)	.065 (1.65)	.062 (1.57)	.2

Dimensions are in inches (mm). Tolerances: 2 Pl. $\pm .01$; 3Pl. $\pm .005$

Notes:

- Case material: Plastic.
- Termination finish:
For RoHS Case Styles: Tin-Silver alloy plate over Nickel barrier or Matte-Tin.
All models, (+) suffix. See model Data sheet.
For RoHS-5 Case Styles: Tin-Lead plate. All models, no (+) suffix.



INTERNET <http://www.minicircuits.com>

P.O. Box 350166, Brooklyn, New York 11235-0003 (718) 934-4500 Fax (718) 332-4661

Distribution Centers NORTH AMERICA 800-654-7949 • 417-335-5935 • Fax 417-335-5945 • EUROPE 44-1252-832600 • Fax 44-1252-837010

Mini-Circuits ISO 9001 & ISO 14001 Certified

Tape & Reel Packaging TR-F55

DEVICE ORIENTATION IN T&R

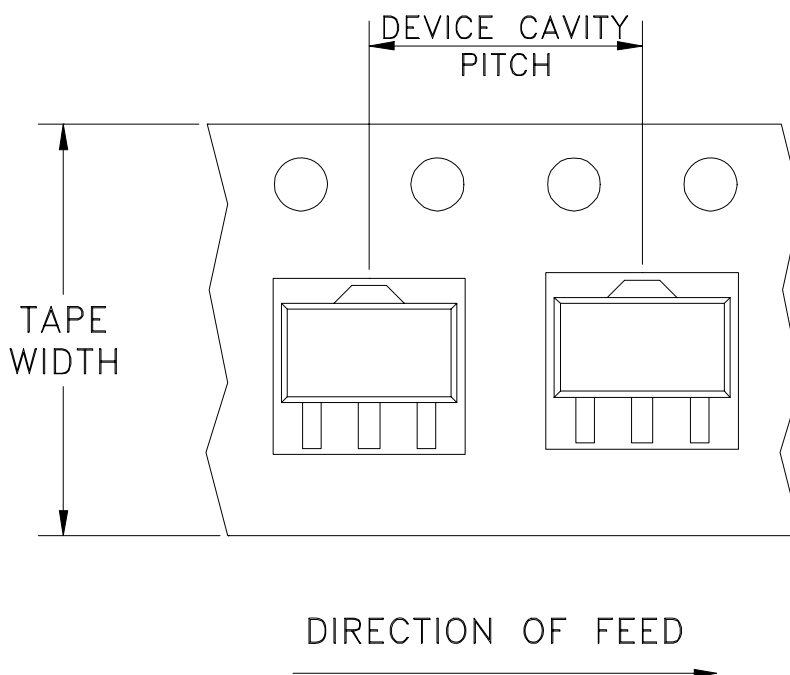

Tape Width, mm	Device Cavity Pitch, mm	Reel Size, inches	Devices per Reel	
12	8	7	Small quantity standard (see note)	20
				50
				100
				200
				500
			Standard	1000

Note: Please consult individual model data sheet to determine device per reel availability.

Mini-Circuits carrier tape materials provide protection from ESD (Electro-Static Discharge) during handling and transportation. Tapes are static dissipative and comply with industry standards EIA-481/EIA-541.

Go to: www.minicircuits.com/pages/pdfs/tape.pdf



INTERNET <http://www.minicircuits.com>

P.O. Box 350166, Brooklyn, New York 11235-0003 (718) 934-4500 Fax (718) 332-4661

Distribution Centers NORTH AMERICA 800-654-7949 • 417-335-5935 • Fax 417-335-5945 • EUROPE 44-1252-832600 • Fax 44-1252-837010

Mini-Circuits ISO 9001 & ISO 14001 Certified

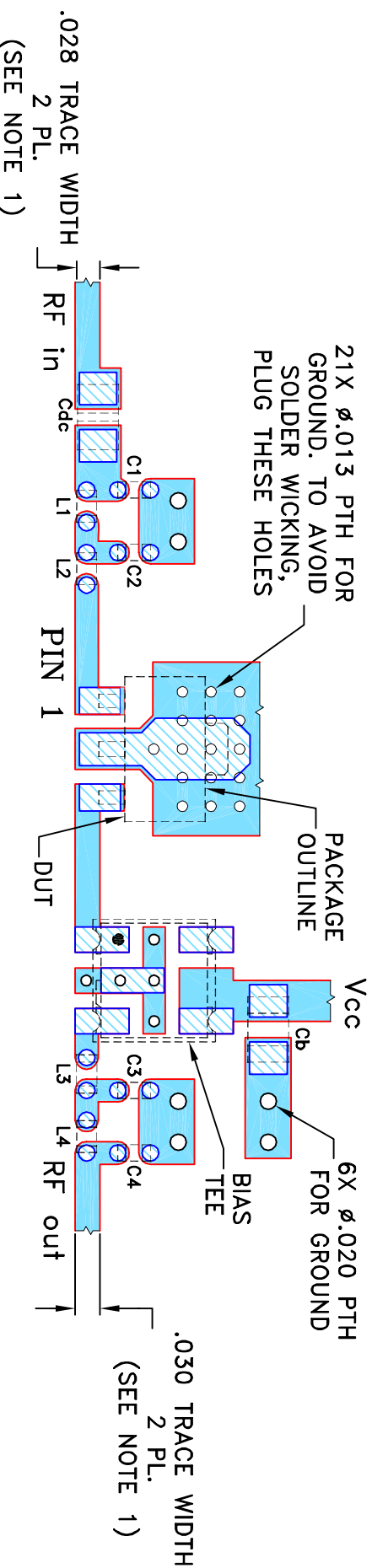

REVISIONS					
REV	ECN No.	DESCRIPTION	DATE	DR	AUTH
OR	M138185	NRE RELEASE	08/08/12	AV	DJ

**SUGGESTED MOUNTING CONFIGURATION
FOR DF782 CASE STYLE, "04AM03" PIN CODE**



COMPONENT	SIZE
C1-C4, L1-L4	0402
CDC, CB	0805

- NOTES:**
- TRACE WIDTH IS SHOWN FOR ROGERS RO4350B WITH DIELECTRIC THICKNESS .030" ± .0015"; COPPER: 1/2 OZ. EACH SIDE. FOR OTHER MATERIALS TRACE WIDTH MAY NEED TO BE MODIFIED.
 - BOTTOM SIDE OF THE PCB IS CONTINUOUS GROUND PLANE.
 - CHIP COMPONENT FOOT PRINTS SHOWN FOR REFERENCE. FOR COMPONENT VALUES REFER TO TB-670+.

 DENOTES PCB COPPER LAYOUT WITH SMOBC
 (SOLDER MASK OVER BARE COPPER)
 DENOTES COPPER LAND PATTERN FREE OF SOLDER MASK

UNLESS OTHERWISE SPECIFIED	INITIALS	DATE
DRAWN	AV	08/02/12
CHECKED	IL	08/08/12
APPROVED	DJ	08/08/12

 13 Neptune Avenue
 Brooklyn NY 11235

PL, 04AM03, 75, DF782, TB-670+

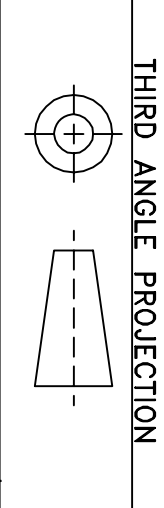

THIS DOCUMENT AND ITS CONTENTS ARE THE PROPERTY OF MINI-CIRCUITS. EXCEPT FOR USE EXPRESSLY GRANTED, IN WRITING, TO ITS VENDORS, VENDORS AND THE UNITED STATES GOVERNMENT, MINI-CIRCUITS RESERVES ALL PROPRIETARY DESIGN, USE, MANUFACTURING AND REPRODUCTION RIGHTS THERETO. THESE CONTENTS SHALL NOT BE USED, DUPLICATED OR DISCLOSED TO ANY OUTSIDE PARTY, IN WHOLE OR IN PART, WITHOUT WRITTEN PERMISSION OF MINI-CIRCUITS.

 Mini-Circuits®
 ASHETL1.DWG REV:A DATE:01/12/95

SIZE	CODE IDENT	DRAWING NO:	REV:
A	15542	98-PL-379	OR

FILE: 98PL379 SCALE: 5:1 SHEET: 1 OF 1

Evaluation Board and Circuit

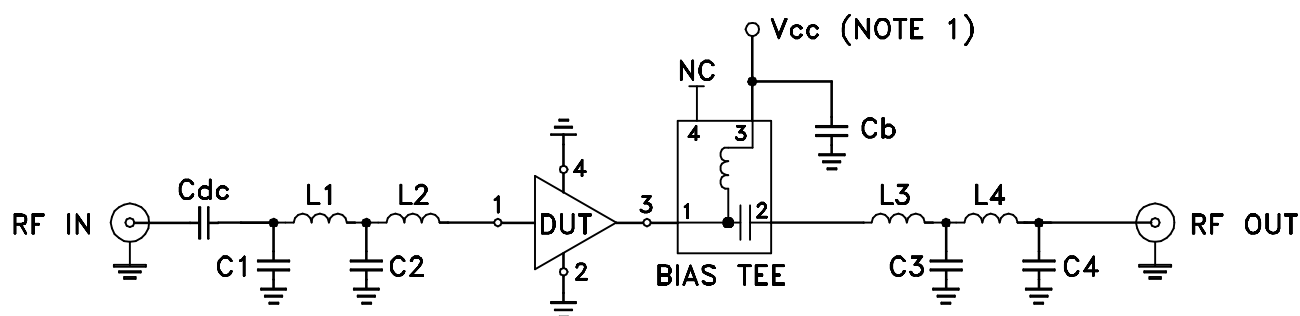
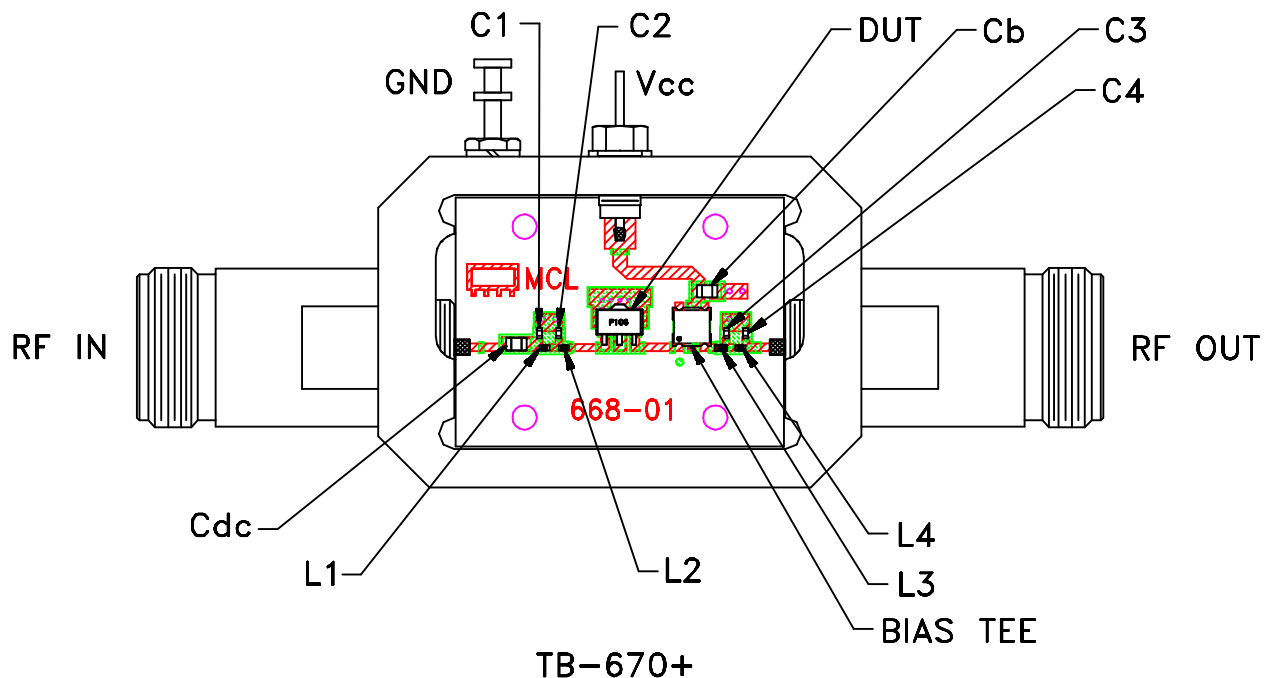

COMPONENT	VALUE	SIZE
DUT	PGA-106-75+	-
BIAS TEE	Mini-Circuits TCBT-14+	-
Cdc	2400 pF	0805
Cb	0.1 uF	0805
C1	0.5 pF	0402
C2	1.3 pF	0402
C3	1.2 pF	0402
C4	0.7 pF	0402
L1,L2,L4	7.5 nH	0402
L3	4.7nH	0402

Schematic Diagram

NOTES:

1. Vcc voltage: +5±0.2V.
2. N-type 75 Ohm connectors.
3. PCB material: Rogers R04350 or equivalent, dielectric constant=3.5, dielectric thickness=.030 inch.

Mini-Circuits®

All Mini-Circuits products are manufactured under exacting quality assurance and control standards, and are capable of meeting published specifications after being subjected to any or all of the following physical and environmental test.

Specification	Test/Inspection Condition	Reference/Spec
Operating Temperature	-40° to 85°C or -45° to 85°C Ambient Environment	Individual Model Data Sheet
Storage Temperature	-55° to 100° C or -65° to 150° Ambient Environment	Individual Model Data Sheet
Thermal Shock	-55° to 100°C, 100 cycles	MIL-STD-202, Method 107, Condition A-3, except +100°C
Mechanical Shock	1.5Kg, 0.5 ms, 5 shock pulses, Y1 direction only	MIL-STD-883, Method 2002, Condition B, except Y1 direction only
Vibration (Variable Frequency)	50g peak	MIL-STD-883, Method 2007, Condition B
Autoclave	15 psig, 100% RH, 121°C, 96 hours	JESD22-A102, Condition C
HAST	130°C, 85% RH, 96 hours	JESD22-A110
Solderability	10X Magnification	J-STD-002, Para 4.2.5, Test S, 95% Coverage
Solder Reflow Heat	Sn-Pb Eutetic Process: 240°C peak Pb-Free Process: 260°C peak	J-STD-020, Table 4-1, 4-2 and 5-2; Figure 5-1
Moisture Sensitivity: Level 1	Bake at 125°C for 24 hours Soak at 85°C/85% RH for 168 hours, Reflow 3 cycles at 260°C peak	J-STD-020
Marking Resistance to Solvents	Isopropyl alcohol + mineral spirits at 25°C; terpene defluxer at 25°C; distilled water + proylene glycol monomethyl ether +	MIL-STD-202, Method 215



All Mini-Circuits products are manufactured under exacting quality assurance and control standards, and are capable of meeting published specifications after being subjected to any or all of the following physical and environmental test.

Specification	Test/Inspection Condition	Reference/Spec
	monoethanolamine at 63°C to 70°C	