



COAXIAL

Adapter, N-F to N-F

NF-NF50+

50Ω DC to 6 GHz

THE BIG DEAL

- Excellent VSWR, 1.05:1 typ.
- Low insertion loss, 0.03 dB typ.
- Tri metal finish



Generic photo used for illustration purposes only

APPLICATIONS

- Interconnection of RF cables and equipment

Model No.	NF-NF50+
Case Style	DJ1092
Connectors	N-Female to N-Female

+RoHS Compliant

The +Suffix identifies RoHS Compliance. See our web site for RoHS Compliance methodologies and qualifications

ELECTRICAL SPECIFICATIONS AT=25°C

Parameter	Frequency (GHz)	Electrical Specification			Units
		Min.	Typ.	Max.	
Frequency Range		DC		6	GHz
Insertion Loss	DC - 6	—	0.05	0.10	dB
VSWR	DC - 2	—	—	1.10	:1
	DC - 4	—	—	1.20	
	DC - 6	—	—	1.20	

MAXIMUM RATINGS

Parameter	Ratings
Operating temperature	-55°C to 100°C
Storage temperature	-55°C to 100°C

Permanent damage may occur if any of these limits are exceeded.

REV. C
ECO-012138
NF-NF50+
MCL NY
220215





COAXIAL

Adapter, N-F to N-F

NF-NF50+

OUTLINE DRAWING

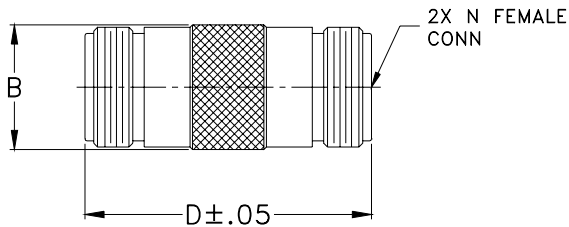

OUTLINE DIMENSIONS (Inches/mm)

A	B	C	D	E	wt
--	.65	--	1.50	--	grams
--	16.5	--	38.00	--	37.2

TYPICAL PERFORMANCE DATA

Frequency (MHz)	Insertion Loss (dB)	VSWR (:1)	
		N-FEMALE	N-FEMALE
0.50	0.00	1.00	1.00
10.00	0.00	1.00	1.00
100.00	0.00	1.00	1.00
500.00	0.01	1.02	1.02
1000.00	0.01	1.03	1.03
1500.00	0.01	1.02	1.03
2000.00	0.01	1.02	1.02
2500.00	0.02	1.01	1.01
3000.00	0.02	1.02	1.01
3500.00	0.02	1.04	1.05
4000.00	0.04	1.08	1.08
4500.00	0.05	1.11	1.12
5000.00	0.03	1.13	1.15
5500.00	0.04	1.12	1.11
6000.00	0.05	1.08	1.12

NF-NF50+
INSERTION LOSS

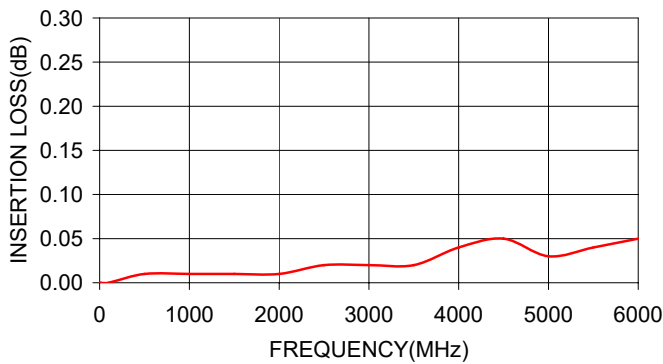

NF-NF50+
VSWR

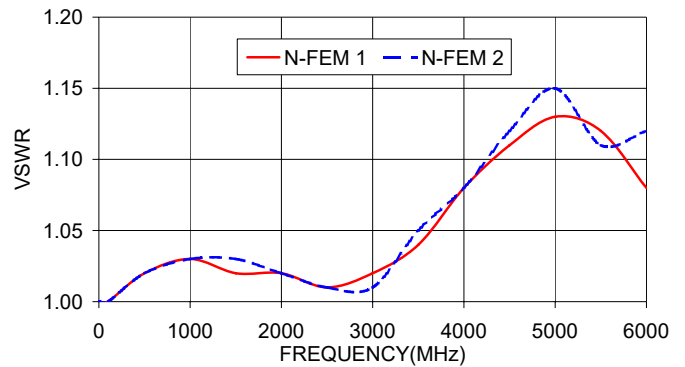

NOTES

- Performance and quality attributes and conditions not expressly stated in this specification document are intended to be excluded and do not form a part of this specification document.
- Electrical specifications and performance data contained in this specification document are based on Mini-Circuit's applicable established test performance criteria and measurement instructions.
- The parts covered by this specification document are subject to Mini-Circuits standard limited warranty and terms and conditions (collectively, "Standard Terms"); Purchasers of this part are entitled to the rights and benefits contained therein. For a full statement of the standard. Terms and the exclusive rights and remedies thereunder, please visit Mini-Circuits' website at www.minicircuits.com/MCLStore/terms.jsp



Adapter, N-Female to N-Female

NF-NF50+

Typical Performance Data

FREQUENCY (MHz)	INSERTION LOSS (dB)	N-FEMALE 1 RETURN LOSS (dB)	N-FEMALE 2 RETURN LOSS (dB)
0.5	0.01	46.06	46.06
10	0.01	46.06	46.06
100	0.01	46.06	46.06
500	0.01	40.09	40.09
1000	0.01	36.61	36.61
1500	0.01	40.09	36.61
2000	0.01	40.09	40.09
2500	0.02	46.06	46.06
3000	0.02	40.09	46.06
3500	0.02	34.15	32.26
4000	0.04	28.30	28.30
4500	0.05	25.66	24.94
5000	0.03	24.29	23.13
5500	0.04	24.94	25.66
6000	0.05	28.30	24.94

REV. X1
NF-NF50+
061114
Page 1 of 1



IF/RF MICROWAVE COMPONENTS • ISO 9001 ISO 14001 AS 9100 CERTIFIED RoHS compliant
P.O. Box 350166, Brooklyn, New York 11235-0003 (718) 934-4500 Fax (718) 332-4661



The Design Engineers Search Engine finds the model you need, Instantly • For detailed performance specs & shopping online see



Typical Performance Curves

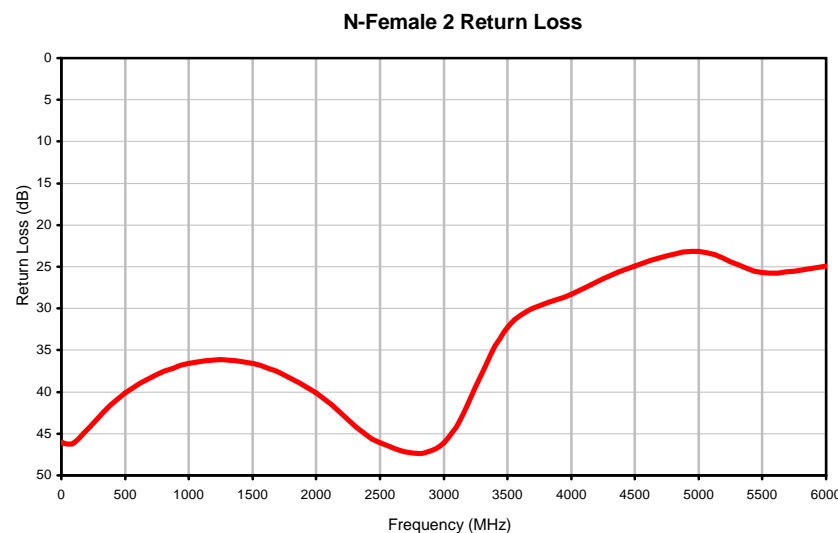
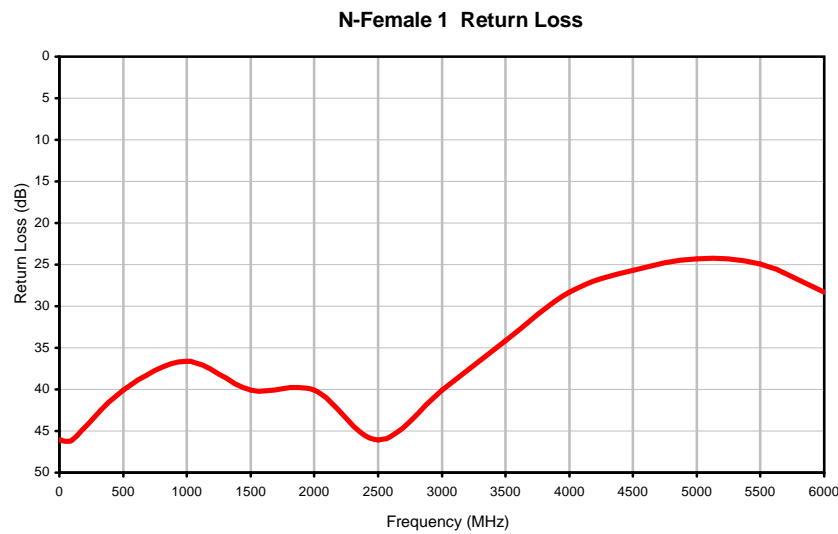
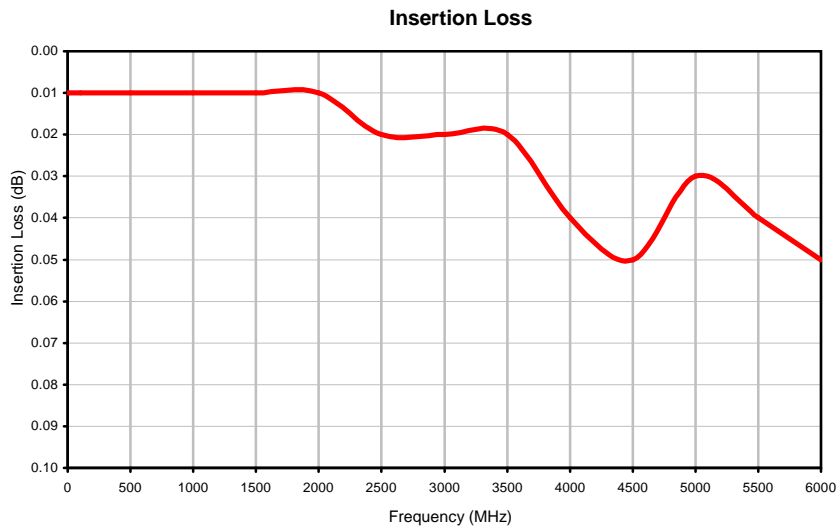

REV. X1
NF-NF50+
061114
Page 1 of 1



RF/MICROWAVE COMPONENTS • ISO 9001 ISO 14001 AS 9100 CERTIFIED RoHS compliant
P.O. Box 350166, Brooklyn, New York 11235-0003 (718) 934-4500 Fax (718) 332-4661



The Design Engineers Search Engine finds the model you need, Instantly • For detailed performance specs & shopping online see



Outline Dimensions

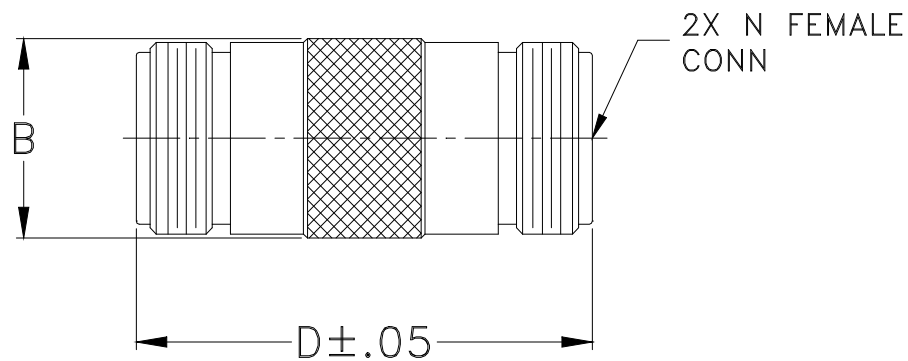

CASE#	A	B	C	D	E	WT. GRAM
DJ1092	--	.65 (16.5)	--	1.50 (38.10)	--	37.2

Dimensions are in inches (mm). Tolerances: 2 Pl. $\pm .03$; 3 Pl. $\pm .015$

Notes:

1. Case material: Brass
2. Finish: Tri-metal (Cu-Sn-Zn) plate.



All Mini-Circuits products are manufactured under exacting quality assurance and control standards, and are capable of meeting published specifications after being subjected to any or all of the following physical and environmental test.

Specification	Test/Inspection Condition	Reference/Spec
Operating Temperature	-55° to 100°C Ambient Environment	Individual Model Data Sheet
Storage Temperature	-55° to 100° C Ambient Environment	Individual Model Data Sheet
Barometric Pressure	100,000 Feet	MIL-STD-202, Method 105, Condition D
Humidity	90% RH, 65°C Units may require bake-out after humidity to restore full performance.	MIL-STD-202, Method 103
Thermal Shock	-65° to 125°C, 5 cycles	MIL-STD-202, Method 107, Condition B
Vibration (High Frequency)	20g peak, 10-2000 Hz, 12 times in each of three perpendicular directions (total 36)	MIL-STD-202, Method 204, Condition D
Mechanical Shock	100g, 6ms sawtooth, 3 shocks each direction 3 axes (total 18)	MIL-STD-202, Method 213, Condition I