

Attenuator Fixed

NAT-20DC+

50Ω 500 to 2300 MHz

Maximum Ratings

Operating Temperature	-55°C to 100°C
Storage Temperature	-55°C to 100°C
Permanent damage may occur if any of these limits are exceeded.	

Features

- high DC current handling
- high DC breakdown voltage
- DC resistance (in/out) 0.1Ω, typ.



CASE STYLE: FF57
Connectors Model
N-Type NAT-20DC+

Applications

- power passing
- instrumentation
- test equipment
- lab use

+RoHS Compliant

The +Suffix identifies RoHS Compliance. See our web site for RoHS Compliance methodologies and qualifications

Outline Drawing

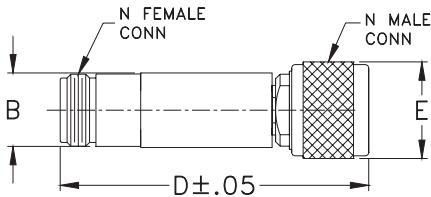

Outline Dimensions (inch/mm)

B	D	E	wt
.67	2.90	.82	grams
17.02	73.66	20.83	90.0

Electrical Specifications (T_{AMB} = 25°C)

FREQUENCY (MHz)	ATTENUATION (dB)		VSWR (:1)	POWER (mW)	DC CURRENT (Amps)	DC BREAKDOWN (Volts)
	Nom.	Flatness, Max.	Max.	Max.	Max.	Max.
500 - 2300	20 ± 0.5	± 1.2	1.80	400	4	125

Typical Performance Data at 25°C

Frequency (MHz)	Attenuation (dB)	VSWR (:1)
500.00	19.49	1.13
600.00	19.77	1.13
700.00	19.96	1.13
800.00	20.10	1.14
900.00	20.14	1.14
1000.00	20.18	1.15
1100.00	20.21	1.16
1200.00	20.14	1.18
1300.00	20.14	1.19
1400.00	20.08	1.21
1450.00	20.07	1.22
1500.00	20.05	1.23
1600.00	20.02	1.26
1700.00	19.95	1.29
1800.00	19.89	1.32
1900.00	19.89	1.36
2000.00	19.86	1.41
2100.00	19.87	1.46
2200.00	19.91	1.53
2300.00	19.98	1.61

Electrical Schematic

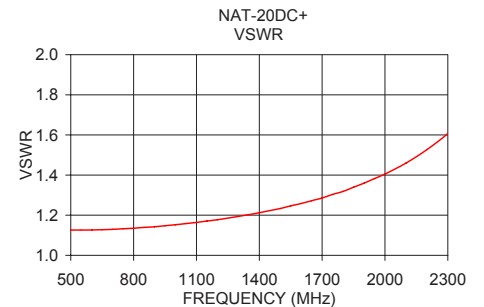
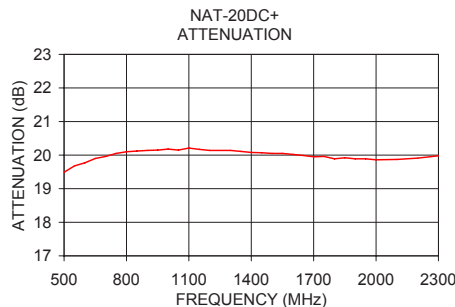
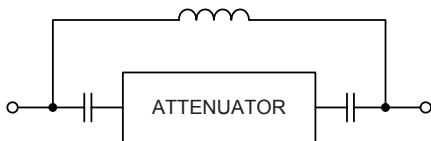

Notes

- Performance and quality attributes and conditions not expressly stated in this specification document are intended to be excluded and do not form a part of this specification document.
- Electrical specifications and performance data contained in this specification document are based on Mini-Circuit's applicable established test performance criteria and measurement instructions.
- The parts covered by this specification document are subject to Mini-Circuits standard limited warranty and terms and conditions (collectively, "Standard Terms"); Purchasers of this part are entitled to the rights and benefits contained therein. For a full statement of the Standard Terms and the exclusive rights and remedies thereunder, please visit Mini-Circuits' website at www.minicircuits.com/MCLStore/terms.jsp



Fixed Attenuator, DC Passing

NAT-20DC+

Typical Performance Data

FREQUENCY (MHz)	ATTENUATION (dB)	FEMALE RETURN LOSS (dB)	MALE RETURN LOSS (dB)
200	16.32	21.05	21.40
300	18.25	22.88	23.31
400	19.03	23.87	24.19
450	19.28	24.21	24.43
500	19.49	24.52	24.54
550	19.68	24.74	24.55
600	19.77	24.97	24.52
650	19.90	25.11	24.43
700	19.96	25.30	24.33
750	20.05	25.39	24.12
800	20.10	25.54	23.98
850	20.12	25.62	23.73
900	20.14	25.70	23.55
950	20.15	25.81	23.25
1000	20.18	25.87	22.99
1050	20.15	25.97	22.69
1100	20.21	26.01	22.41
1150	20.17	26.11	22.08
1200	20.14	26.11	21.77
1250	20.14	26.14	21.43
1300	20.14	26.13	21.07
1350	20.11	26.09	20.72
1400	20.08	26.05	20.36
1450	20.07	25.95	19.98
1500	20.05	25.94	19.62
1550	20.05	25.77	19.20
1600	20.02	25.73	18.83
1650	19.99	25.49	18.43
1700	19.95	25.40	18.06
1750	19.96	25.14	17.60
1800	19.89	24.95	17.24
1850	19.92	24.61	16.77
1900	19.89	24.35	16.34
1950	19.89	24.00	15.89
2000	19.86	23.61	15.47
2100	19.87	22.78	14.57
2200	19.91	21.78	13.62
2300	19.98	20.68	12.66
2400	20.13	19.45	11.63
2500	20.44	18.06	10.67

REV. X1
NAT-20DC+
061109
Page 1 of 1



IF/RF MICROWAVE COMPONENTS • ISO 9001 ISO 14001 AS 9100 CERTIFIED RoHS compliant
P.O. Box 350166, Brooklyn, New York 11235-0003 (718) 934-4500 Fax (718) 332-4661



The Design Engineers Search Engine finds the model you need, Instantly • For detailed performance specs & shopping online see



Typical Performance Curves

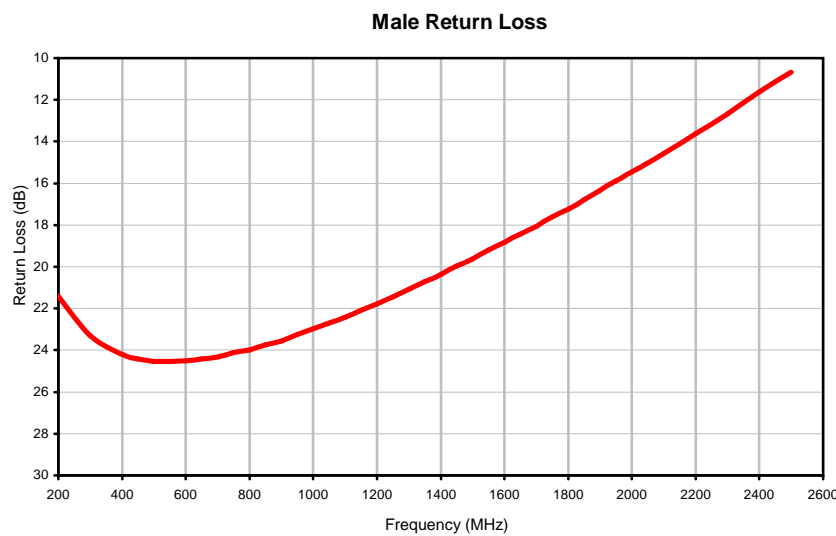
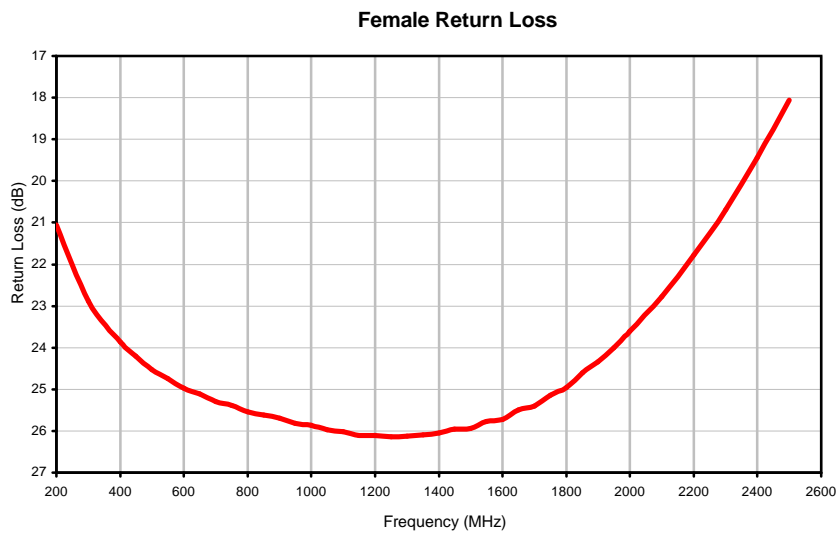
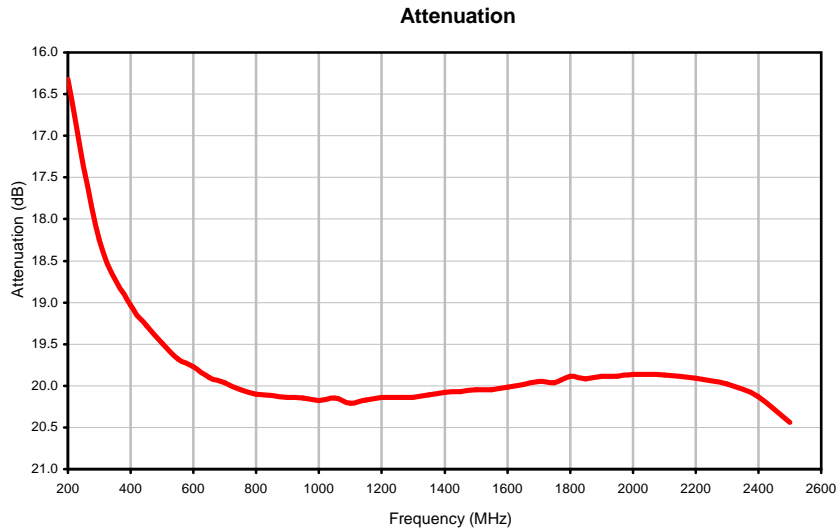

Outline Dimensions

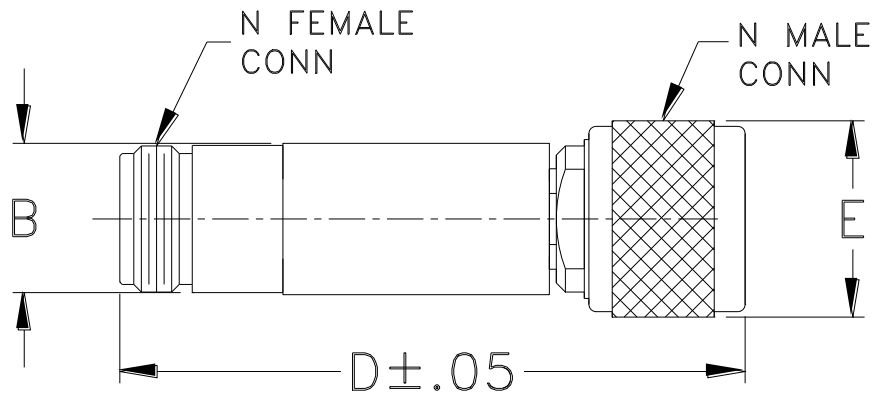

CASE #.	A	B	C	D	E	WT GRAMS
FF57	--	.70 (17.78)	--	2.90 (73.66)	.82 (20.83)	90.0

Dimensions are in inches (mm). Tolerances: 2Pl. ± .03; 3Pl. ± .015

Note:

1. Case material: Stainless steel.



All Mini-Circuits products are manufactured under exacting quality assurance and control standards, and are capable of meeting published specifications after being subjected to any or all of the following physical and environmental test.

Specification	Test/Inspection Condition	Reference/Spec
Operating Temperature	-55° to 100°C Ambient Environment	Individual Model Data Sheet
Storage Temperature	-55° to 100° C Ambient Environment	Individual Model Data Sheet
Barometric Pressure	100,000 Feet	MIL-STD-202, Method 105, Condition D
Humidity	90% RH, 65°C Units may require bake-out after humidity to restore full performance.	MIL-STD-202, Method 103
Thermal Shock	-65° to 125°C, 5 cycles	MIL-STD-202, Method 107, Condition B
Vibration (High Frequency)	20g peak, 10-2000 Hz, 12 times in each of three perpendicular directions (total 36)	MIL-STD-202, Method 204, Condition D
Mechanical Shock	100g, 6ms sawtooth, 3 shocks each direction 3 axes (total 18)	MIL-STD-202, Method 213, Condition I