

# DC Passing Attenuator Fixed

## NAT-15DC-1.5A+

50Ω 950 to 4000 MHz

### Maximum Ratings

Operating Temperature	-55°C to 100°C
Storage Temperature	-55°C to 100°C

Permanent damage may occur if any of these limits are exceeded.

### Features

- high DC current handling
- high DC breakdown voltage
- DC resistance (in/out) 0.1Ω, typ.



Generic photo used for illustration purposes only

CASE STYLE: FF57

Connectors	Model
N-Type	NAT-15DC-1.5A+

### Applications

- power passing
- instrumentation
- test equipment
- lab use

**+RoHS Compliant**

The +Suffix identifies RoHS Compliance. See our web site for RoHS Compliance methodologies and qualifications

### Outline Drawing

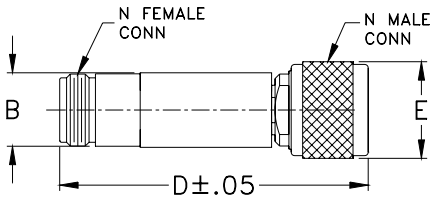

### Outline Dimensions (inch/mm)

B	D	E	wt
.67	2.90	.82	grams
17.02	73.66	20.83	90.0

### Electrical Specifications (T<sub>AMB</sub> = 25°C)

FREQUENCY (MHz)	ATTENUATION (dB)		VSWR (:1)	POWER (mW)	DC CURRENT (Amps)	DC BREAK-DOWN (Volts)
	Nom.	Flatness, Max.	Max.	Max.	Max.	Max.
950-4000	15±0.7	±0.6	1.6	1000	1.5	50

### Typical Performance Data at 25°C

Frequency (MHz)	Attenuation (dB)	VSWR (:1)
950.00	15.48	1.42
1000.00	15.40	1.34
1200.00	15.25	1.17
1400.00	15.20	1.12
1600.00	15.18	1.12
1800.00	15.19	1.15
2000.00	15.21	1.18
2200.00	15.18	1.21
2400.00	15.12	1.23
2600.00	15.13	1.25
2800.00	15.10	1.26
3000.00	15.08	1.26
3200.00	15.01	1.26
3400.00	14.93	1.25
3500.00	14.93	1.24
3600.00	14.90	1.23
3700.00	14.87	1.21
3800.00	14.88	1.19
3900.00	14.94	1.16
4000.00	15.10	1.12

### Electrical Schematic

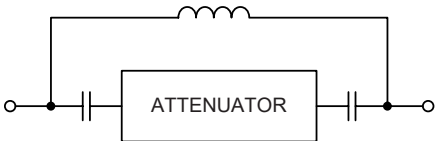

NAT-15DC-1.5A+ ATTENUATION

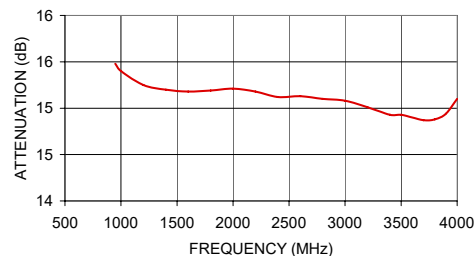

NAT-15DC-1.5A+ VSWR

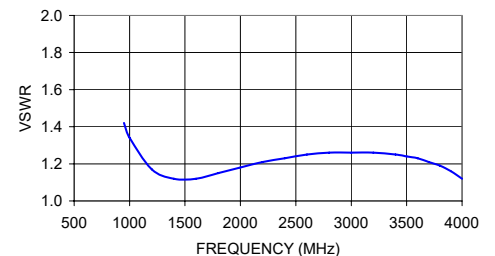

### Notes

- Performance and quality attributes and conditions not expressly stated in this specification document are intended to be excluded and do not form a part of this specification document.
- Electrical specifications and performance data contained in this specification document are based on Mini-Circuit's applicable established test performance criteria and measurement instructions.
- The parts covered by this specification document are subject to Mini-Circuits standard limited warranty and terms and conditions (collectively, "Standard Terms"); Purchasers of this part are entitled to the rights and benefits contained therein. For a full statement of the Standard Terms and the exclusive rights and remedies thereunder, please visit Mini-Circuits' website at [www.minicircuits.com/MCLStore/terms.jsp](http://www.minicircuits.com/MCLStore/terms.jsp)



# Fixed Attenuator, DC Passing

# NAT-15DC-1.5A+

## Typical Performance Data

FREQUENCY (MHz)	ATTENUATION (dB)	FEMALE RETURN LOSS (dB)	MALE RETURN LOSS (dB)
950	15.48	14.12	15.21
1000	15.40	15.38	16.75
1200	15.25	19.08	22.12
1400	15.20	20.08	24.94
1600	15.18	19.40	24.94
1800	15.19	18.22	23.13
2000	15.21	17.21	21.66
2200	15.18	16.54	20.44
2400	15.12	16.13	19.73
2600	15.13	15.94	19.08
2800	15.10	15.94	18.78
3000	15.08	16.13	18.78
3200	15.01	16.54	18.78
3400	14.93	17.21	19.08
3500	14.93	17.69	19.40
3600	14.90	18.22	19.73
3700	14.87	18.78	20.44
3800	14.88	19.40	21.23
3900	14.94	20.44	22.61
4000	15.10	22.12	24.94

REV. X1  
NAT-15DC-1.5A+  
070329  
Page 1 of 1



IF/RF MICROWAVE COMPONENTS • ISO 9001 ISO 14001 AS 9100 CERTIFIED RoHS compliant  
P.O. Box 350166, Brooklyn, New York 11235-0003 (718) 934-4500 Fax (718) 332-4661



The Design Engineers Search Engine finds the model you need, Instantly • For detailed performance specs & shopping online see



## Typical Performance Curves

Attenuation

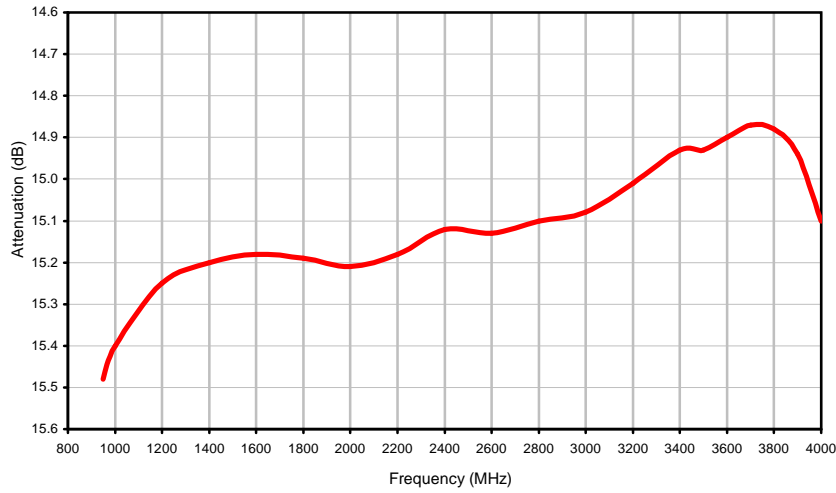

Female Return Loss

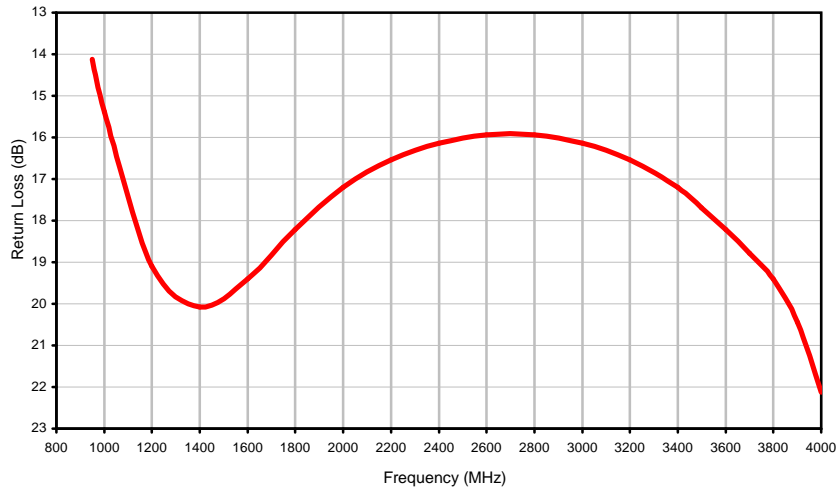

Male Return Loss

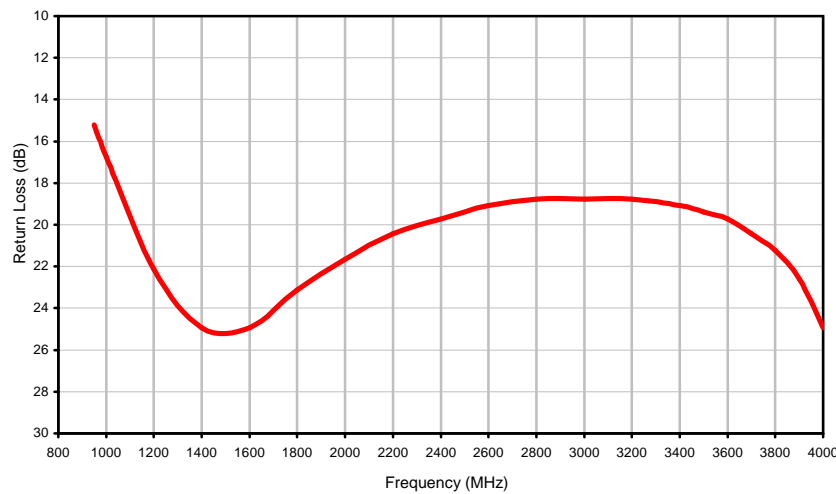

### Outline Dimensions

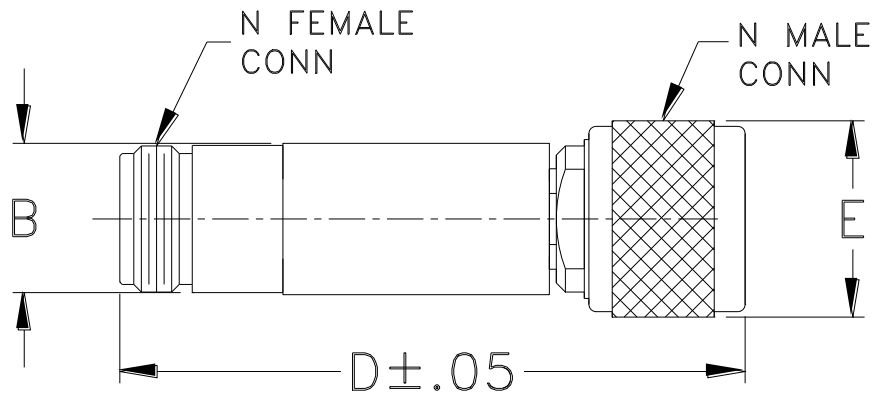

CASE #.	A	B	C	D	E	WT GRAMS
FF57	--	.70 (17.78)	--	2.90 (73.66)	.82 (20.83)	90.0

Dimensions are in inches (mm). Tolerances: 2Pl. ± .03; 3Pl. ± .015

#### Note:

1. Case material: Stainless steel.



All Mini-Circuits products are manufactured under exacting quality assurance and control standards, and are capable of meeting published specifications after being subjected to any or all of the following physical and environmental test.

<b>Specification</b>	<b>Test/Inspection Condition</b>	<b>Reference/Spec</b>
Operating Temperature	-55° to 100°C Ambient Environment	Individual Model Data Sheet
Storage Temperature	-55° to 100° C Ambient Environment	Individual Model Data Sheet
Barometric Pressure	100,000 Feet	MIL-STD-202, Method 105, Condition D
Humidity	90% RH, 65°C Units may require bake-out after humidity to restore full performance.	MIL-STD-202, Method 103
Thermal Shock	-65° to 125°C, 5 cycles	MIL-STD-202, Method 107, Condition B
Vibration (High Frequency)	20g peak, 10-2000 Hz, 12 times in each of three perpendicular directions (total 36)	MIL-STD-202, Method 204, Condition D
Mechanical Shock	100g, 6ms sawtooth, 3 shocks each direction 3 axes (total 18)	MIL-STD-202, Method 213, Condition I