

# Surface Mount Switch

50Ω SPDT, Absorptive DC<sup>3</sup> to 2.0 GHz

# MSWA-2-20+



Generic photo used for illustration purposes only

CASE STYLE: XX211

**+RoHS Compliant**

The +Suffix identifies RoHS Compliance. See our web site for RoHS Compliance methodologies and qualifications



Available Tape and Reel at no extra cost

Reel Size	Devices/Reel
7"	20, 50, 100, 200, 500, 1000
13"	2000

## Maximum Ratings

Operating Temperature	-40°C to 85°C
Storage Temperature	-55°C to 100°C
Input Power	see Note 1
Control Current	see Note 2
Permanent damage may occur if any of these limits are exceeded.	

## Pin Connections

RF IN	2
RF OUT 1	8
RF OUT 2	5
CONTROL 1	3
CONTROL 2	1
GROUND	4,6,7

## Outline Drawing

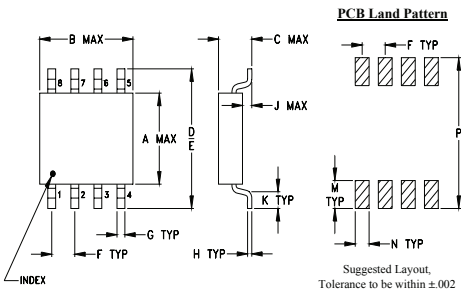

## Outline Dimensions (inch/mm)

A	B	C	D	E	F	G
.163	.210	.077	.250	.220	.050	.017
4.14	5.33	1.96	6.35	5.59	1.27	0.43
H	J	K	M	N	P	wt
.009	.025	.030	.050	.030	.270	grams
0.23	0.64	0.76	1.27	0.76	6.86	0.10

## Demo Board MCL P/N: TB-205 Suggested PCB Layout (PL-219)

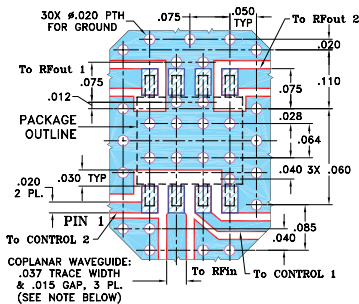

- NOTE:
- COPLANAR WAVEGUIDE PARAMETERS ARE SHOWN FOR ROGERS R04350B WITH DIELECTRIC THICKNESS .020" ± .0015"; COPPER: 1/2 OZ. EACH SIDE. FOR OTHER MATERIALS TRACE WIDTH & GAP MAY NEED TO BE MODIFIED.
  - BOTTOM SIDE OF THE PCB IS CONTINUOUS GROUND PLANE.
  - DENOTES PCB COPPER LAYOUT WITH SMOBC (SOLDER MASK OVER BARE COPPER)
  - DENOTES COPPER LAND PATTERN FREE OF SOLDER MASK

## Notes

- Performance and quality attributes and conditions not expressly stated in this specification document are intended to be excluded and do not form a part of this specification document.
- Electrical specifications and performance data contained in this specification document are based on Mini-Circuit's applicable established test performance criteria and measurement instructions.
- The parts covered by this specification document are subject to Mini-Circuits standard limited warranty and terms and conditions (collectively, "Standard Terms"); Purchasers of this part are entitled to the rights and benefits contained therein. For a full statement of the Standard Terms and the exclusive rights and remedies thereunder, please visit Mini-Circuits' website at [www.minicircuits.com/MCLStore/terms.jsp](http://www.minicircuits.com/MCLStore/terms.jsp)

## Features

- wideband, DC to 2.0 GHz
- low video leakage, 8 mVp-p typ.
- very fast switching, 5ns typ.

## Applications

- cellular
- PCN
- 2-way radio
- receiver antenna switching

## Electrical Specifications

FREQ. <sup>3</sup> (GHz)	INSERTION LOSS (dB)				1dB COMPR. (dBm)				IN-OUT ISOLATION (dB)											
	DC-100 MHz	100-500 MHz	500-1000 MHz	1000-2000 MHz	DC-100 MHz	100-500 MHz	500-1000 MHz	1000-2000 MHz	DC-100 MHz	100-500 MHz	500-1000 MHz	1000-2000 MHz								
f <sub>L</sub>	Typ.	Max.	Typ.	Max.	Typ.	Typ.	Typ.	Typ.	Typ.	Min.	Typ.	Min.	Typ.	Min.						
DC 2.0	0.65	0.9	0.9	1.2	0.95	1.3	1.20	1.5	20	24	27	29	60	50	45	37	40	32	30	25

## Additional Specifications

Control Voltage	-8/0 for compression spec, -8 to -5/0 for all other specs	
Control Current, mA	0.2 max to -8V, 0.02 max at 0 to -0.2V	
VSWR:(:1)	DC-1GHz 1.2 typ.	1-2GHz 1.4 typ.
Rise/Fall time (10%-90%), ns	3 typ.	
Switching time, 50% of Control to 90% RF(Turn-on), ns	9 typ	
10% RF(Turn-off), ns	3 typ	
**Video Leakage, mVp-p 0/-5V Control	19 typ.	

## CONTROL LOGIC

Control Ports		RF outputs	
1	2	1	2
0	-V	Off	On
-V	0	On	Off

\*\* Video leakage or break through is defined as leakage of switching signal to RF output ports.

- RF Power Input (dBm), Max. DC-100MHz 100-500 MHz 500-2000MHz
  - Steady State Control 0/-8V 24 27 33
  - As a Modulator 12 17 23
- Control Current, 500µA (occurs at -9V to -12V typ.)
- All RF connections must be DC blocked or held at 0V DC.

## Electrical Schematic

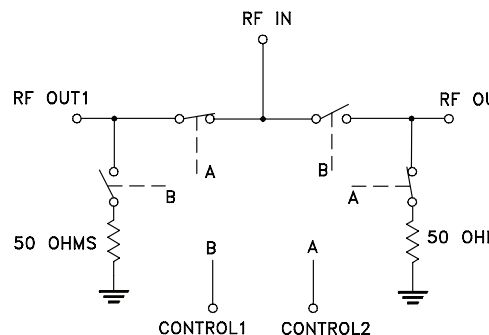

## Typical Performance Data

FREQ. (MHz)	ON INSERTION LOSS (dB) Control @ 0V/-5V)		OFF ISOLATION (dB) Control @ 0V/-5V)		VSWR	
	RF IN-RF OUT		RF IN - RF OUT	RF OUT 1-RF OUT 2	RF IN	RF OUT
	0.3	0.55	86.64	87.15	1.11	1.11
10.0	0.57	78.95	81.46	1.09	1.10	
100.0	0.59	61.84	67.44	1.07	1.08	
200.0	0.60	56.95	57.49	1.08	1.09	
300.0	0.60	54.13	54.74	1.09	1.10	
400.0	0.60	52.77	50.08	1.09	1.10	
500.0	0.61	50.05	47.79	1.09	1.10	
600.0	0.61	47.67	45.68	1.09	1.10	
700.0	0.61	45.86	43.87	1.10	1.11	
800.0	0.61	44.23	41.94	1.09	1.11	
900.0	0.62	42.57	40.21	1.09	1.12	
1000.0	0.62	41.06	38.64	1.09	1.13	
1100.0	0.62	39.61	37.10	1.08	1.14	
1200.0	0.63	38.25	35.67	1.07	1.15	
1300.0	0.63	36.95	34.30	1.06	1.16	
1400.0	0.63	35.70	33.02	1.05	1.16	
1500.0	0.64	34.52	31.82	1.04	1.16	
1600.0	0.65	33.41	30.67	1.04	1.15	
1700.0	0.67	32.34	29.57	1.04	1.15	
1800.0	0.68	31.24	28.52	1.05	1.15	
1900.0	0.69	30.21	27.51	1.06	1.15	
2000.0	0.71	29.26	26.54	1.08	1.16	

MSWA-2-20+  
INSERTION LOSS

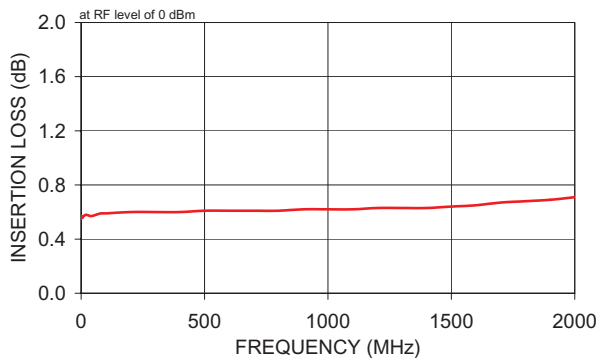

MSWA-2-20+  
ISOLATION

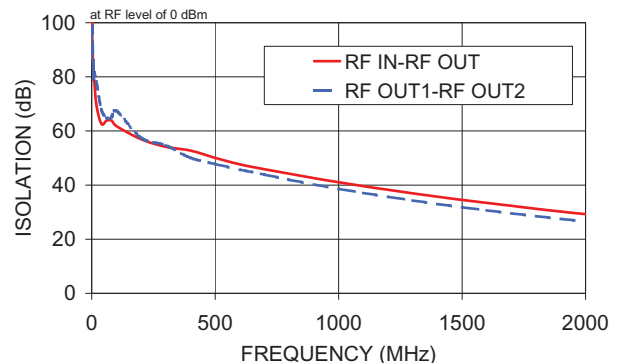

MSWA-2-20+  
VSWR

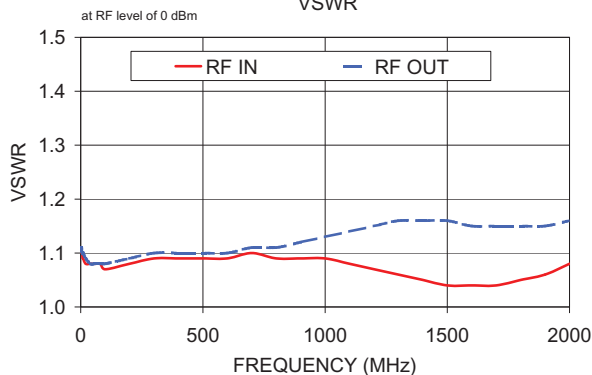

**Notes**

- A. Performance and quality attributes and conditions not expressly stated in this specification document are intended to be excluded and do not form a part of this specification document.
- B. Electrical specifications and performance data contained in this specification document are based on Mini-Circuit's applicable established test performance criteria and measurement instructions.
- C. The parts covered by this specification document are subject to Mini-Circuits standard limited warranty and terms and conditions (collectively, "Standard Terms"); Purchasers of this part are entitled to the rights and benefits contained therein. For a full statement of the Standard Terms and the exclusive rights and remedies thereunder, please visit Mini-Circuits' website at [www.minicircuits.com/MCLStore/terms.jsp](http://www.minicircuits.com/MCLStore/terms.jsp)



## Typical Performance Data

Control Voltage: 0V/-5V

RF FREQ (MHz)	INSERTION LOSS*		ISOLATION*				VSWR*					
	(dB)		(dB)				(:1)					
	RF IN-RF OUT1	RF IN-RF OUT2	RF IN-RF OUT1	RF IN-RF OUT2	RF OUT1-RF OUT2	RF OUT1-RF OUT2	RF IN	RF IN	RF OUT1	RF OUT2	RF OUT1	RF OUT2
	RF OUT1 ON	RF OUT2 ON	RF OUT2 ON	RF OUT1 ON	RF OUT1 ON	RF OUT2 ON	RF OUT1 ON	RF OUT2 ON	RF OUT1 ON	RF OUT2 ON	RF OUT1 OFF	RF OUT2 OFF
0.3	0.55	0.55	92.25	86.64	87.82	87.15	1.11	1.11	1.11	1.11	1.10	1.09
0.5	0.57	0.58	92.12	100.12	92.20	106.63	1.11	1.11	1.11	1.11	1.10	1.10
1.0	0.57	0.57	100.66	98.10	99.54	103.56	1.11	1.11	1.11	1.11	1.10	1.09
2.0	0.56	0.57	90.84	96.01	87.99	99.03	1.11	1.11	1.11	1.11	1.10	1.09
4.0	0.56	0.57	84.82	88.31	92.97	92.13	1.10	1.10	1.11	1.11	1.10	1.09
6.0	0.56	0.57	83.02	84.73	87.03	83.98	1.10	1.10	1.10	1.10	1.10	1.09
8.0	0.57	0.57	74.94	78.63	82.79	79.25	1.09	1.09	1.10	1.10	1.10	1.09
10.0	0.57	0.57	75.93	78.95	80.95	81.46	1.09	1.09	1.10	1.10	1.10	1.09
20.0	0.58	0.59	65.75	69.11	75.58	77.62	1.08	1.09	1.09	1.09	1.10	1.09
40.0	0.57	0.58	59.03	62.56	66.74	67.57	1.08	1.08	1.08	1.08	1.09	1.09
60.0	0.58	0.59	60.72	63.80	67.27	64.85	1.08	1.08	1.08	1.08	1.09	1.09
80.0	0.59	0.60	60.11	63.88	69.56	65.05	1.08	1.08	1.08	1.08	1.09	1.08
100.0	0.59	0.60	57.17	61.84	78.44	67.44	1.07	1.08	1.08	1.08	1.09	1.08
200.0	0.60	0.61	53.07	56.95	71.36	57.49	1.08	1.08	1.09	1.09	1.09	1.09
300.0	0.60	0.60	49.00	54.13	64.72	54.74	1.09	1.09	1.10	1.10	1.10	1.09
400.0	0.60	0.60	47.54	52.77	57.10	50.08	1.09	1.09	1.10	1.11	1.10	1.10
500.0	0.61	0.61	45.23	50.05	53.79	47.79	1.09	1.10	1.10	1.11	1.10	1.11
600.0	0.61	0.61	43.28	47.67	50.65	45.68	1.09	1.10	1.10	1.12	1.11	1.11
700.0	0.61	0.61	41.71	45.86	48.26	43.87	1.10	1.10	1.11	1.12	1.11	1.12
800.0	0.61	0.61	40.35	44.23	45.71	41.94	1.09	1.10	1.11	1.13	1.11	1.13
900.0	0.62	0.61	39.01	42.57	43.53	40.21	1.09	1.10	1.12	1.14	1.12	1.13
1000.0	0.62	0.62	37.78	41.06	41.60	38.64	1.09	1.10	1.13	1.15	1.12	1.14
1100.0	0.62	0.62	36.62	39.61	39.81	37.10	1.08	1.10	1.14	1.16	1.13	1.15
1200.0	0.63	0.63	35.50	38.25	38.17	35.67	1.07	1.10	1.15	1.17	1.13	1.15
1300.0	0.63	0.64	34.41	36.95	36.64	34.30	1.06	1.09	1.16	1.18	1.14	1.16
1400.0	0.63	0.65	33.37	35.70	35.25	33.02	1.05	1.08	1.16	1.18	1.14	1.17
1500.0	0.64	0.65	32.35	34.52	33.92	31.82	1.04	1.08	1.16	1.19	1.15	1.17
1600.0	0.65	0.66	31.38	33.41	32.68	30.67	1.04	1.08	1.15	1.18	1.15	1.18
1700.0	0.67	0.67	30.44	32.34	31.50	29.57	1.04	1.07	1.15	1.18	1.16	1.19
1800.0	0.68	0.68	29.50	31.24	30.32	28.52	1.05	1.07	1.15	1.17	1.17	1.20
1900.0	0.69	0.69	28.56	30.21	29.24	27.51	1.06	1.08	1.15	1.17	1.18	1.21
2000.0	0.71	0.71	27.66	29.26	28.20	26.54	1.08	1.08	1.16	1.17	1.19	1.21

\*Note:

CONTROL LOGIC			
Control Ports		RF Outputs	
1	2	1	2
0	-5V	Off	On
-5V	0	On	Off



P.O. Box 350166, Brooklyn, New York 11235-0003 (718) 934-4500 • Fax (718) 332-4661 For detailed performance specs & shopping online see Mini-Circuits web site



The Design Engineers Search Engine Provides ACTUAL Data Instantly From MINI-CIRCUITS At: [www.minicircuits.com](http://www.minicircuits.com)

IF/RF MICROWAVE COMPONENTS

## Typical Performance Data

Control Voltage: 0V/-8V

RF FREQ (MHz)	INSERTION LOSS*		ISOLATION*				VSWR*					
	(dB)		(dB)				(:1)					
	RF IN-RF OUT1	RF IN-RF OUT2	RF IN-RF OUT1	RF IN-RF OUT2	RF OUT1-RF OUT2	RF OUT1-RF OUT2	RF IN	RF IN	RF OUT1	RF OUT2	RF OUT1	RF OUT2
	RF OUT1 ON	RF OUT2 ON	RF OUT2 ON	RF OUT1 ON	RF OUT1 ON	RF OUT2 ON	RF OUT1 ON	RF OUT2 ON	RF OUT1 ON	RF OUT2 ON	RF OUT1 OFF	RF OUT2 OFF
0.3	0.55	0.55	99.20	93.50	94.78	86.98	1.11	1.11	1.11	1.11	1.10	1.10
0.5	0.56	0.56	91.94	103.85	103.06	98.99	1.11	1.11	1.11	1.11	1.10	1.10
1.0	0.55	0.56	94.83	106.44	103.57	95.93	1.10	1.10	1.10	1.10	1.10	1.10
2.0	0.55	0.56	91.37	87.77	113.77	93.16	1.10	1.10	1.10	1.10	1.10	1.09
4.0	0.55	0.55	84.15	88.56	92.70	94.02	1.10	1.10	1.10	1.10	1.10	1.10
6.0	0.55	0.56	81.74	85.34	86.87	85.11	1.09	1.09	1.10	1.10	1.10	1.09
8.0	0.55	0.56	74.79	73.85	77.78	83.85	1.09	1.09	1.09	1.09	1.10	1.09
10.0	0.56	0.56	75.21	77.36	86.48	83.89	1.09	1.09	1.10	1.09	1.10	1.09
20.0	0.56	0.57	65.81	69.36	75.90	78.23	1.08	1.08	1.09	1.08	1.10	1.09
40.0	0.56	0.57	59.06	63.00	67.57	66.86	1.08	1.08	1.08	1.08	1.09	1.09
60.0	0.57	0.58	60.38	63.91	67.37	64.74	1.08	1.08	1.08	1.08	1.09	1.09
80.0	0.58	0.59	60.11	63.94	69.64	65.03	1.08	1.08	1.08	1.08	1.09	1.09
100.0	0.59	0.59	56.52	61.39	88.45	70.25	1.07	1.08	1.08	1.08	1.09	1.09
200.0	0.59	0.60	52.84	56.51	71.78	57.84	1.08	1.08	1.09	1.09	1.09	1.09
300.0	0.60	0.60	49.26	54.58	63.48	54.24	1.09	1.09	1.10	1.10	1.10	1.10
400.0	0.60	0.60	47.55	52.83	57.42	50.12	1.09	1.09	1.10	1.11	1.10	1.10
500.0	0.60	0.60	45.23	50.16	54.11	47.92	1.10	1.10	1.11	1.12	1.10	1.11
600.0	0.60	0.60	43.35	47.82	50.92	45.77	1.10	1.11	1.11	1.12	1.11	1.12
700.0	0.60	0.60	41.82	46.07	48.44	43.87	1.10	1.11	1.12	1.13	1.11	1.12
800.0	0.61	0.61	40.43	44.41	46.00	42.07	1.10	1.12	1.12	1.14	1.12	1.13
900.0	0.61	0.61	39.14	42.81	43.85	40.36	1.10	1.12	1.13	1.15	1.12	1.14
1000.0	0.62	0.62	37.92	41.31	41.89	38.80	1.10	1.12	1.14	1.17	1.13	1.15
1100.0	0.62	0.62	36.78	39.88	40.12	37.30	1.10	1.12	1.15	1.18	1.13	1.15
1200.0	0.62	0.63	35.67	38.54	38.49	35.88	1.09	1.12	1.17	1.19	1.14	1.16
1300.0	0.63	0.64	34.63	37.28	36.97	34.52	1.09	1.12	1.17	1.20	1.15	1.17
1400.0	0.63	0.64	33.60	36.05	35.56	33.25	1.08	1.11	1.18	1.21	1.15	1.18
1500.0	0.64	0.65	32.61	34.87	34.25	32.06	1.07	1.11	1.18	1.21	1.16	1.18
1600.0	0.65	0.66	31.67	33.78	33.02	30.92	1.07	1.11	1.17	1.21	1.16	1.19
1700.0	0.66	0.67	30.74	32.72	31.85	29.84	1.07	1.11	1.17	1.20	1.17	1.20
1800.0	0.67	0.68	29.81	31.68	30.70	28.80	1.07	1.10	1.17	1.20	1.18	1.21
1900.0	0.69	0.69	28.90	30.64	29.59	27.80	1.08	1.10	1.17	1.20	1.19	1.22
2000.0	0.70	0.70	28.01	29.67	28.55	26.84	1.09	1.10	1.17	1.20	1.20	1.23

\*Note:

CONTROL LOGIC			
Control Ports		RF Outputs	
1	2	1	2
0	-8V	Off	On
-8V	0	On	Off



P.O. Box 350166, Brooklyn, New York 11235-0003 (718) 934-4500 • Fax (718) 332-4661 For detailed performance specs & shopping online see Mini-Circuits web site



The Design Engineers Search Engine Provides ACTUAL Data Instantly From MINI-CIRCUITS At: [www.minicircuits.com](http://www.minicircuits.com)

IF/RF MICROWAVE COMPONENTS

# RF Absorptive Switch SPDT

## Typical Performance Curves

**MSWA-2-20+**

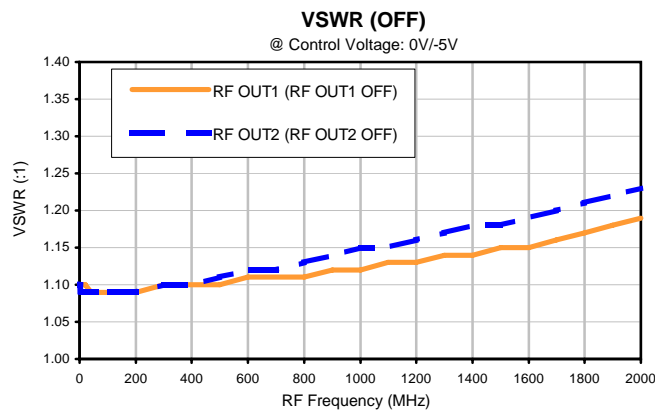
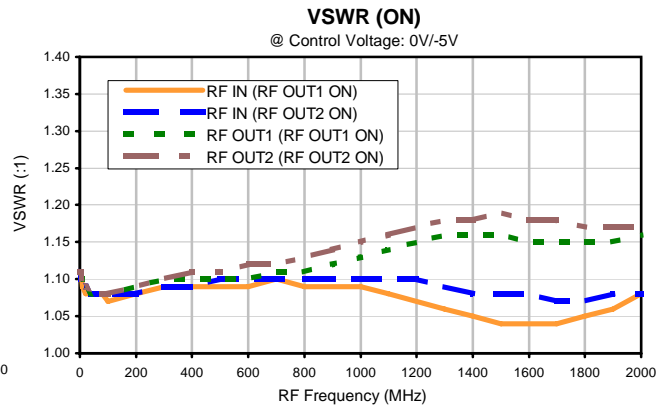
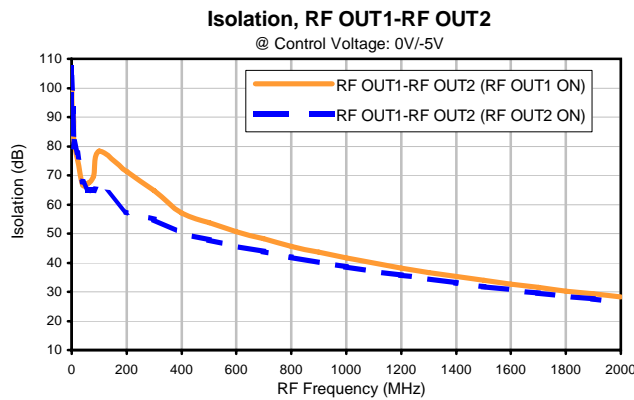
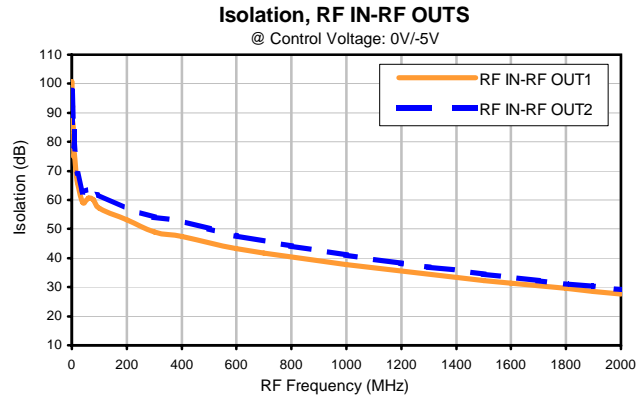
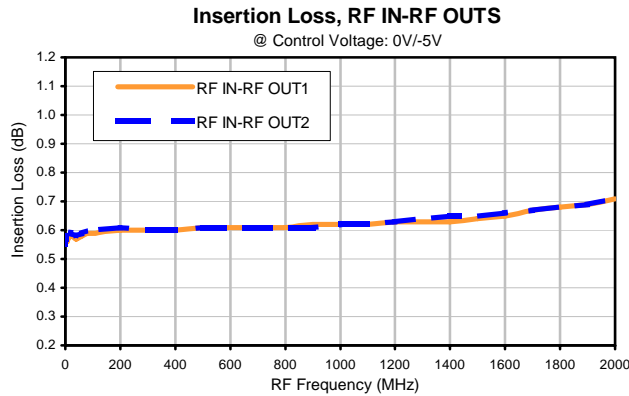

## Typical Performance Curves

**Insertion Loss, RF IN-RF OUTS**

@ Control Voltage: 0V/-8V

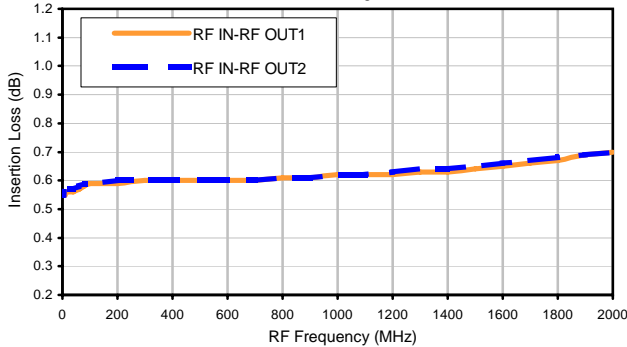

**Isolation, RF IN-RF OUTS**

@ Control Voltage: 0V/-8V

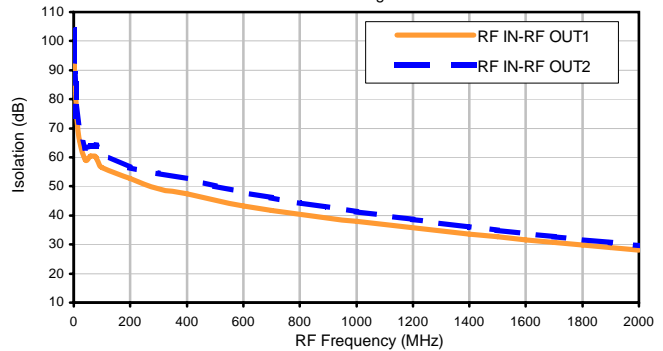

**Isolation, RF OUT1-RF OUT2**

@ Control Voltage: 0V/-8V

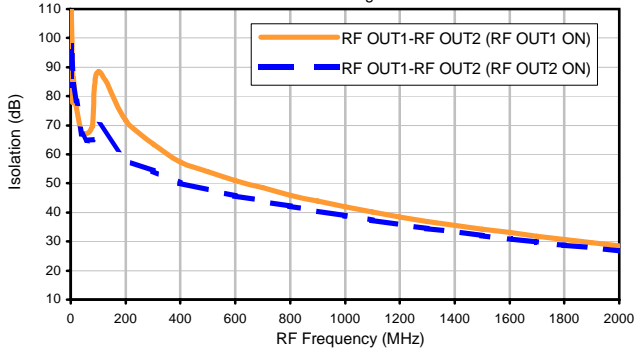

**VSWR (ON)**

@ Control Voltage: 0V/-8V

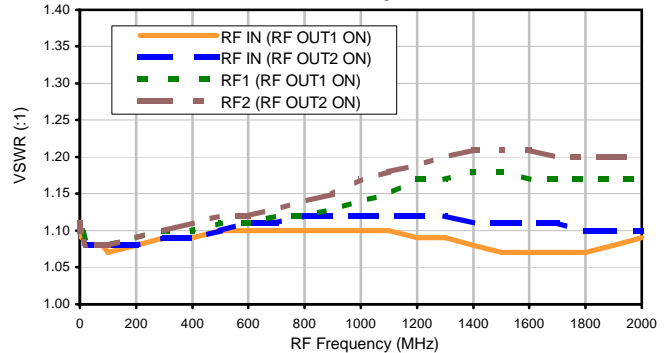

**VSWR (OFF)**

@ Control Voltage: 0V/-8V

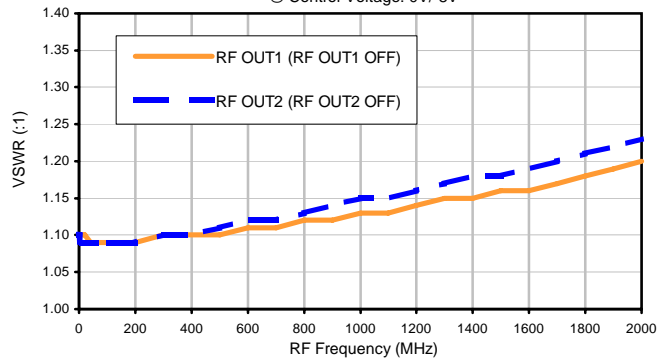

### Outline Dimensions

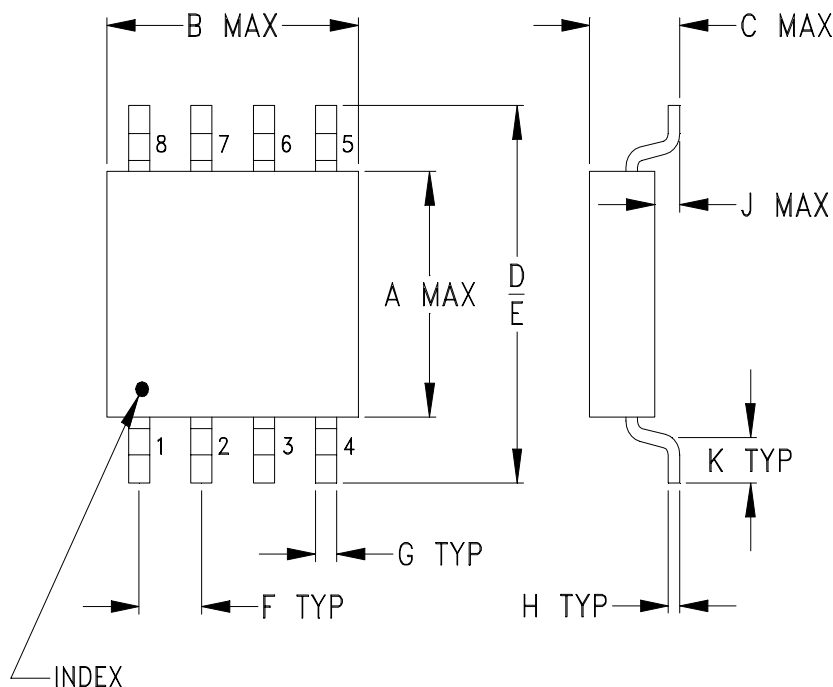

### PCB Land Pattern

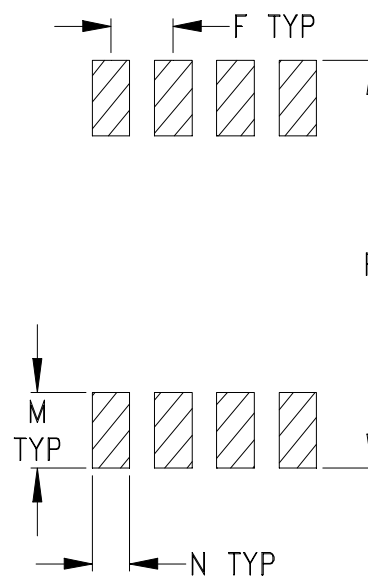

Suggested Layout,  
Tolerance to be within  $\pm .002$

CASE #	A	B	C	D	E	F	G	H	J	K	L	M	N	P
XX211	.163 (4.14)	.210 (5.33)	.077 (1.96)	.250 (6.35)	.220 (5.59)	.050 (1.27)	.017 (0.43)	.009 (0.23)	.025 (0.64)	.030 (0.76)	--	.050 (1.27)	.030 (0.76)	.270 (6.86)

CASE #	Q	R	S	WT. GRAM
XX211	--	--	--	.10

Dimensions are in inches (mm). Tolerances: 2 Pl.  $\pm .03$ ; 3 Pl.  $\pm .015$

#### Notes:

- Case material: Plastic.
  - Termination finish:  
For RoHS Case Styles: Tin-Silver alloy plate over Nickel barrier. All models, (+) suffix.  $\otimes$   
For RoHS-5 Case Styles: Tin-Lead plate. All models, No (+) suffix.
  - Special Tolerances: Termination width  $\pm .005$  inch, termination thickness  $\pm .003$  inch.
- $\otimes$  Model BP4C+ will be supplied with either Tin finish or Tin-Silver-Nickel finish until Tin finish inventory is depleted.



INTERNET <http://www.minicircuits.com>

P.O. Box 350166, Brooklyn, New York 11235-0003 (718) 934-4500 Fax (718) 332-4661

Distribution Centers NORTH AMERICA 800-654-7949 • 417-335-5935 • Fax 417-335-5945 • EUROPE 44-1252-832600 • Fax 44-1252-837010

Mini-Circuits ISO 9001 & ISO 14001 Certified

# Tape & Reel Packaging TR-F16

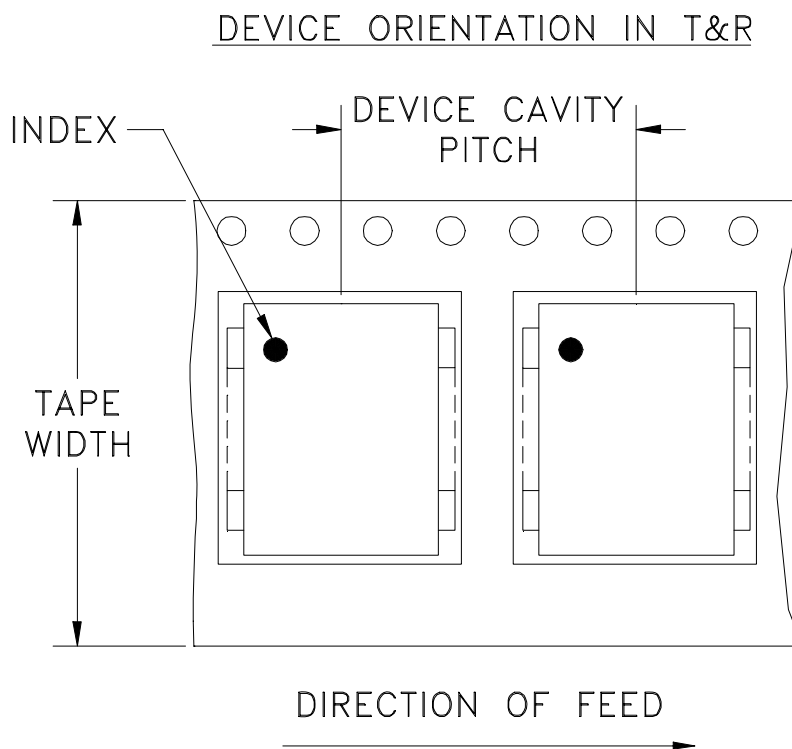

Tape Width, mm	Device Cavity Pitch, mm	Reel Size, inches	Devices per Reel	
12	8	7	Small quantity standards (see note)	20
				50
				100
				200
				500
		Standard	1000*	
		13	Standard	2000**

Note : Please Consult individual model data sheet to determine device per reel availability

\* BP models only

\*\* MSW and MSWA models

Mini-Circuits carrier tape materials provide protection from ESD (Electro-Static Discharge) during handling and transportation. Tapes are static dissipative and comply with industry standards EIA-481/EIA-541.

Go to: [www.minicircuits.com/pages/pdfs/tape.pdf](http://www.minicircuits.com/pages/pdfs/tape.pdf)



INTERNET <http://www.minicircuits.com>

P.O. Box 350166, Brooklyn, New York 11235-0003 (718) 934-4500 Fax (718) 332-4661

Distribution Centers NORTH AMERICA 800-654-7949 • 417-335-5935 • Fax 417-335-5945 • EUROPE 44-1252-832600 • Fax 44-1252-837010

Mini-Circuits ISO 9001 & ISO 14001 Certified



THIRD ANGLE PROJECTION

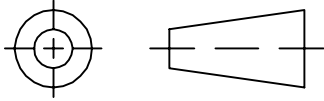

REVISIONS

REV	ECN No.	DESCRIPTION	DATE	DR	AUTH
OR	M100870	NEW RELEASE	10/12/05	MMG	IG
A	M102713	ADDED "...WITH SMOBC"	01/12/06	GT	IL

**SUGGESTED MOUNTING CONFIGURATION  
FOR XX211 CASE STYLE, "es" PIN CONNECTION.**

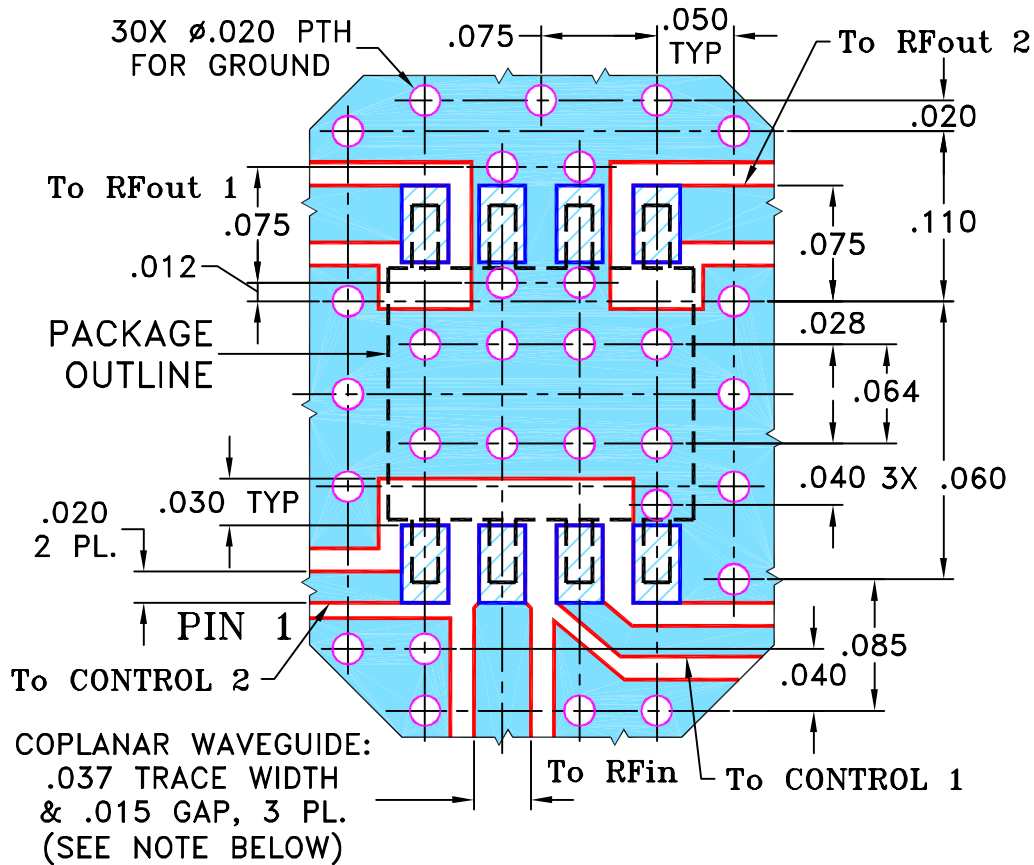

NOTE:

1. COPLANAR WAVEGUIDE PARAMETERS ARE SHOWN FOR ROGERS RO4350B WITH DIELECTRIC THICKNESS .020" ± .0015"; COPPER: 1/2 OZ. EACH SIDE. FOR OTHER MATERIALS TRACE WIDTH & GAP MAY NEED TO BE MODIFIED.
2. BOTTOM SIDE OF THE PCB IS CONTINUOUS GROUND PLANE.

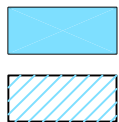

SOLID BLUE DENOTES PCB COPPER LAYOUT WITH SMOBC (SOLDER MASK OVER BARE COPPER)  
 HATCHED BLUE DENOTES COPPER LAND PATTERN FREE OF SOLDER MASK

UNLESS OTHERWISE SPECIFIED	INITIALS	DATE
DIMENSIONS ARE IN INCHES	MMG	09/27/05
TOLERANCES ON:	IL	10/12/05
2 PL DECIMALS ±	IG	10/12/05
3 PL DECIMALS ± .005		
ANGLES ±		
FRACTIONS ±		

**Mini-Circuits®** 13 Neptune Avenue  
Brooklyn NY 11235

PL, es, XX211, MSA-2-20, TB-205

Mini-Circuits®  
 THIS DOCUMENT AND ITS CONTENTS ARE THE PROPERTY OF MINI-CIRCUITS. EXCEPT FOR USE EXPRESSLY GRANTED, IN WRITING, TO ITS VENDORS, VENDEE AND THE UNITED STATES GOVERNMENT, MINI-CIRCUITS RESERVES ALL PROPRIETARY DESIGN, USE, MANUFACTURING AND REPRODUCTION RIGHTS THERETO. THESE CONTENTS SHALL NOT BE USED, DUPLICATED OR DISCLOSED TO ANY OUTSIDE PARTY, IN WHOLE OR IN PART, WITHOUT WRITTEN PERMISSION OF MINI-CIRCUITS.  
 ASHEETA1.DWG REV:A DATE:01/12/95

SIZE	CODE IDENT	DRAWING NO:	REV:
A	15542	98-PL-219	A
FILE:	98PL219	SCALE:	8:1
SHEET:	1	OF	1

# Evaluation Board and Circuit

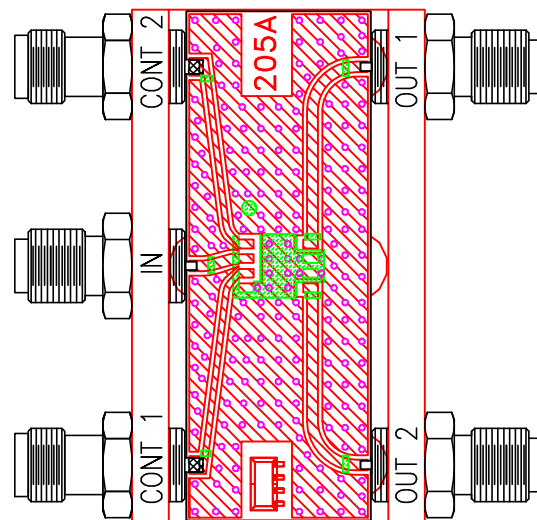

TB-205

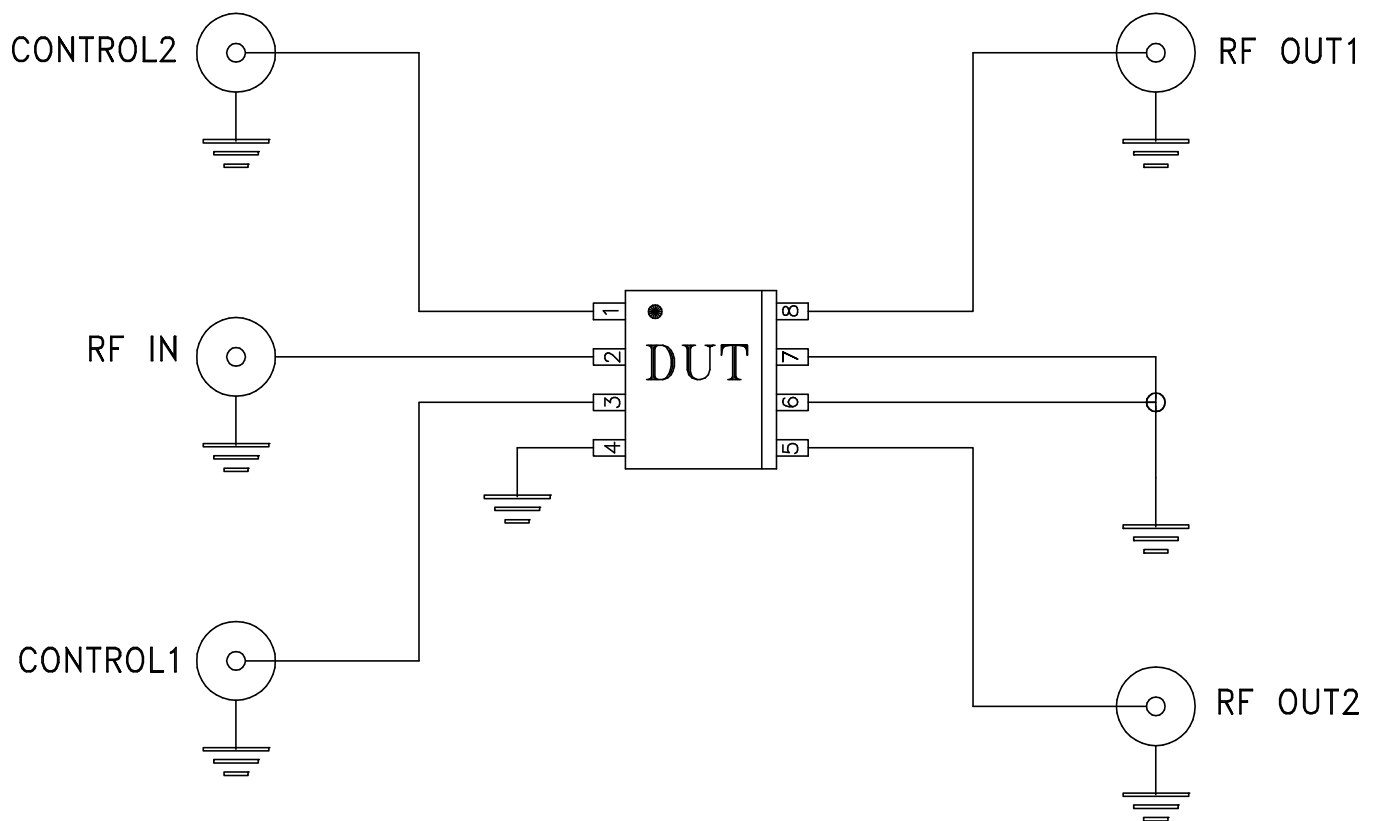

Schematic Diagram

## Notes:

1. SMA Female connectors.
2. PCB Material: Rogers RO4350 or equivalent,  
Dielectric Constant=3.5, Thickness=.020 inch.

 **Mini-Circuits®**

All Mini-Circuits products are manufactured under exacting quality assurance and control standards, and are capable of meeting published specifications after being subjected to any or all of the following physical and environmental test.

Specification	Test/Inspection Condition	Reference/Spec
Operating Temperature	-40° to 85° C Ambient Environment	Individual Model Data Sheet
Storage Temperature	-55° to 100° C Ambient Environment	Individual Model Data Sheet
Temperature Cycling	-55° to 100°C, 100 cycles	MIL-STD-883, Method 1010, Condition B, except 100°C
Autoclave	15 psig, 100% RH, 121°C, 96 hours	JESD22-A102-C, Condition C
HAST	130°C, 85% RH, 96 hours	JESD22-A110
Solder Reflow Heat	Sn-Pb Eutetic Process: 240°C peak Pb-Free Process: 260°C peak	J-STD-020, Table 4-1, 4-2 and 5-2; Figure 5-1
Vibration (High Frequency)	20g peak, 20-2000 Hz, 2 times in each of three perpendicular directions (total 6)	MIL-STD-883, Method 2007. 3, Condition A, Except 2X number of cycles
Mechanical Shock	50g, 11 ms, 1/2-sine, 18 shocks: 3 each direction, each of 3 axes	MIL-STD-202, Method 213, Condition A
Marking Resistance to Solvents	Isopropyl alcohol + mineral spirits at 25°C; terpene defluxer at 25°C; distilled water + proylene glycol monomethyl ether + monoethanolamine at 63°C to 70°C	MIL-STD-202, Method 215