

Surface Mount

# Dual Matched MMIC Amplifier **MPGA-105+**

50Ω      0.04 to 3 GHz



CASE STYLE: DL1020

## The Big Deal

- Excellent gain flatness,  $\pm 0.5$  dB
- Dual matched amplifier for push-pull & balanced amplifiers
- High dynamic range, High OIP3 & Low NF

## Product Overview

MPGA-105+ is a dual matched wideband amplifier fabricated using advanced E-PHEMT technology, offering high dynamic range (High IP3 and Low NF) for use in 50 and 75 ohm applications. This model has demonstrated exceptionally high IP2 in wideband 50 and 75 ohm amplifier evaluation boards. Combining this performance with low noise figure makes it suitable for use in very high dynamic range amplifiers.

## Key Features

Feature	Advantages
Broadband	Covers many communication bands including cellular, cable TV, PCS, SATCOM, WiMAX, and more.
Excellent Gain Flatness: $\pm 0.5$ dB over 0.1-2 GHz	Requires no gain compensation in most wideband applications.
Matched pair for use in high IP3 and IP2 amplifiers	Typical gain match of 0.2 dB and phase match of $0.7^\circ$ , enables it to be used in push-pull amplifiers. Outstanding IP2.
High IP3, up to 40 dBm	Ideal for suppressing unwanted intermods in the presence of multiple carriers, now common in many communication systems.
High P1dB, Up to 21 dBm	High P1dB enables the amplifier to operate in linear region in the presence of strong interfering signals.
Low Noise Figure: 1.7-1.9 dB typical	Together with High OIP3/P1dB, results in high dynamic range



### Product Features

- Two matched amplifiers in one package
- High IP3, +37.5 dBm at 0.9 GHz
- High IP2, +59 dBm at 0.9 GHz in push-pull configuration
- Gain, 14.4 dB typ. at 0.9 GHz
- Excellent Gain Flatness, ±0.5 dB (0.1-2 GHz)
- P1dB, +21 dBm typ. at 0.9 GHz
- Low noise figure, 1.9 dB typ. at 0.9 GHz

### Typical Applications

- SATCOM
- CATV
- FTTH
- Optical networks
- Base station infrastructure
- Balanced amplifiers
- 75 Ohm push-pull and balanced amplifiers

### General Description

MPGA-105+ (RoHS compliant) is an advanced ultra-flat gain amplifier fabricated using E-PHEMT technology and offers extremely high dynamic range over a broad frequency range and with low noise figure. In addition, the MPGA-105+ has good input and output return loss over a broad frequency range without the need for external matching components. It is enclosed in a 4.9 x 6 mm MCLP package for good thermal performance.

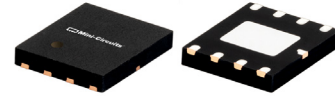

Generic photo used for illustration purposes only

## MPGA-105+

CASE STYLE: DL1020

### +RoHS Compliant

The +Suffix identifies RoHS Compliance. See our web site for RoHS Compliance methodologies and qualifications

### simplified schematic (each of A1, A2) and pad description

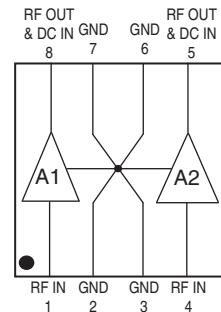
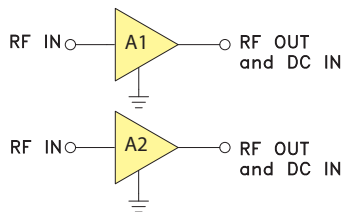

Function	Pad Number	Description
RF IN, A1	1	RF input pin. This pin requires the use of an external DC blocking capacitor chosen for the frequency of operation. (see Application circuit, Fig 2.)
RF-OUT and DC-IN, A1	8	RF output and bias pin. DC voltage is present on this pin; therefore a DC blocking capacitor is necessary for proper operation. An RF choke is needed to feed DC bias without loss of RF signal due to the bias connection, as shown in "Recommended Application Circuit", Fig 2
RF IN, A2	4	RF input pin. This pin requires the use of an external DC blocking capacitor chosen for the frequency of operation. (see Application circuit, Fig 2.)
RF-OUT and DC-IN, A2	5	RF output and bias pin. DC voltage is present on this pin; therefore a DC blocking capacitor is necessary for proper operation. An RF choke is needed to feed DC bias without loss of RF signal due to the bias connection, as shown in "Recommended Application Circuit", Fig 2
GND	2,3,6,7 & paddle	Connections to ground. Use via holes as shown in "Suggested Layout for PCB Design" to reduce ground path inductance for best performance.

\* Enhancement mode pseudomorphic High Electron Mobility Transistor.

## Electrical Specifications<sup>1</sup> at 25°C, Zo=50Ω and Device Voltage 5V, unless noted

(Specifications other than Matching or where defined as push-pull are for each of the two matched amplifiers in the package)

Parameter	Condition (GHz)	Min.	Typ.	Max.	Units
Frequency Range	0.04	0.04	16.0	3.0	GHz
Gain	0.5	13.0	14.6	15.9	dB
	0.9		14.4		
	2.0		14.1		
	2.6		14.3		
	3.0		14.0		
Gain Flatness	0.1-2.0		±0.5		dB
Input Return Loss	0.04	15.0	11.3		dB
	0.5		24.3		
	0.9		20.6		
	2.0		19.0		
	2.6		11.6		
Output Return Loss	0.04		12.6		dB
	0.5		20.5		
	0.9		15.1		
	2.0		8.2		
	2.6		7.4		
Output Power @ 1 dB compression <sup>(2,6)</sup>	0.04		21.0		dBm
	0.5		20.5		
	0.9		21.0		
	2.0		19.8		
	2.6		19.8		
Output IP3 <sup>(6)</sup>	0.04	35.5	35.9		dBm
	0.5		37.6		
	0.9		37.8		
	2.0		34.1		
	2.6		32.5		
Noise Figure	0.04		1.7		dB
	0.5		1.9		
	0.9		1.9		
	2.0		1.8		
	2.6		1.7		
Matching between A1, A2	Amplitude Unbalance	0.04		0.0	dB
		0.5		0.1	
		0.9		0.1	
		2.0		0.2	
		2.6		0.3	
	Phase Unbalance	0.04		0.7	deg.
		0.5		0.4	
		0.9		0.8	
		2.0		1.6	
		2.6		1.4	
3.0		0.8			
Device Operating Voltage		4.8	5.0	5.2	V
Device Operating Current (each amplifier)			63	77	mA
Device Current Variation vs. Temperature			80		μA/°C
Device Current Variation vs Voltage			0.014		mA/mV
Thermal Resistance, junction-to-ground lead <sup>(7)</sup>			47		°C/W

### Absolute Maximum Ratings<sup>(4)</sup>

Parameter	Ratings
Operating Temperature	-40°C to 85°C
Storage Temperature	-65°C to 150°C
Operating Current at 5V <sup>(6)</sup>	94 mA
Power Dissipation <sup>(6)</sup>	0.47 W
Input Power (CW) <sup>(6)</sup>	23 dBm (5 minutes max, 17 dBm (continuous))
DC Voltage (pads 5, 8)	5.5V

<sup>(1)</sup> Measured on Mini-Circuits Test Board TB-561-105+, see characterization circuit, Fig 1.

<sup>(2)</sup> Current increases at P1dB

<sup>(3)</sup> Measured on evaluation boards (push-pull amplifiers) TB-666-50-105+.

See characterization Test Circuit (Fig 1b)

<sup>(4)</sup> Permanent damage may occur if any of these limits are exceeded.

<sup>(5)</sup> Defined with reference to ground pad temperature.

<sup>(6)</sup> Per single ended amplifier.

<sup>(7)</sup> θjc= (Junction Temperature - 85°C) / (Voltage X sum of current in A1 & A2)

### Push-Pull Amplifier Typical Performance<sup>(3)</sup>

Frequency (GHz)	Gain (dB)	Output IP3 (dBm)	Output IP2 (dBm)
0.04	12.2	34.4	66.6
0.5	12.3	35.8	58.7
0.9	11.4	43.3	59.4
2.0	10.4	35.1	55.3
2.6	8.7	35.0	66.9
3.0	8.1	34.9	67.8



Characterization Test Circuit

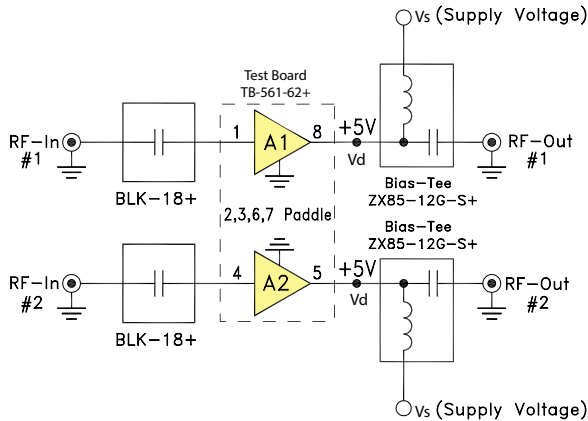

**Fig 1a.** Block Diagram of Test Circuit used for characterization. (DUT tested in Mini-Circuits Test board TB-561-105+, except for IP2). Gain, Return loss, Output power at 1dB compression (P1 dB), output IP3 (OIP3) and noise figure measured using Agilent’s N5242A PNA-X microwave network analyzer.

**Conditions:**

1. Gain and Return loss: Pin= -25dBm
2. Output IP3 (OIP3): Two tones, spaced 1MHz apart, 0 dBm/tone at output.

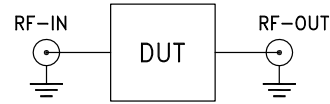

Mini-Circuits Evaluation Boards, 50Ω Push-Pull Amplifiers TB-666-50-105+ (MPGA-105+ inside)

**Fig 1b.** Block Diagram of Test Set up used for characterization of Gain, IP2, IP3 of push-pull amplifier. Measured using Agilent’s signal generators E8527D and Spectrum analyzer N9020A.

**Conditions:**

1. Gain and Return loss: Pin= -25dBm
2. Output IP3 & IP2: Two tones, spaced 1MHz apart, 8 dBm/tone at output. IP2 is measured at the sum frequency of the tones.

Recommended Application Circuit

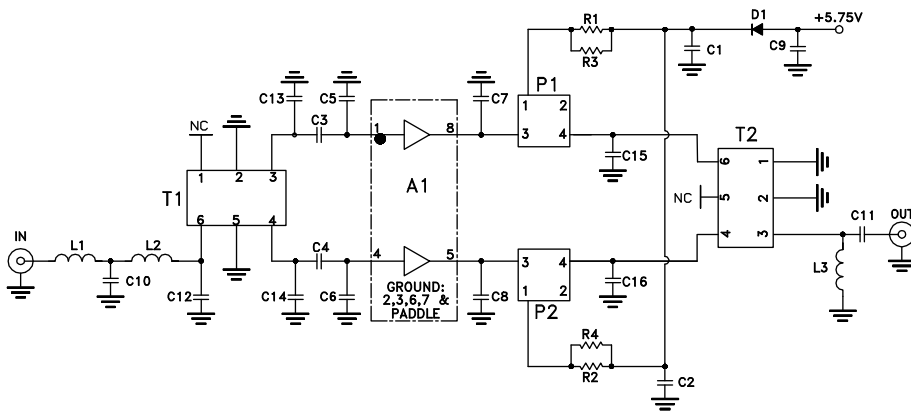

COMPONENT	VALUE	SIZE
A1	Mini-Circuits MPGA-105+	PER DATA SHEET
C1,C2	.039 uF	0805
C3,C4	.001 uF	0402
C5,C6	.2 pF	0402
C7,C8	1.1 pF	0402
C9	1.0 uF	1311
C10	.4 pF	0603
C11	270 pF	0805
C12	.4 pF	0402
C13	.7 pF	0402
C14	.3 pF	0402
C15	.6 pF	0402
C16	1.0 pF	0402
D1	Diode, Schottky Rectifier Vf=.385V @ .5A, Vr=10V MAX	-
L1,L2	1.1 nH	.073"X.054"
L3	1.5 uH	1008
R1,R2	5.11 Ohm	1206
R3,R4	7.50 Ohm	1206
T1	Mini-Circuits TCM2-33WX+	PER DATA SHEET
T2	Mini-Circuits TCM2-43X+	PER DATA SHEET
P1,P2	Mini-Circuits TCBT-6G+	PER DATA SHEET

**Fig 2.** Recommended Application Circuit. Mini-Circuits Evaluation Board 50Ω: TB-666-50-105+

Product Marking

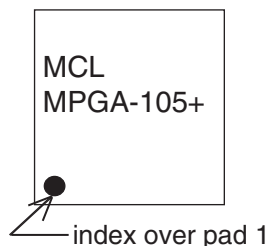

<b>Additional Detailed Technical Information</b>	
<i>additional information is available on our dash board. To access this information <a href="#">click here</a></i>	
<b>Performance Data</b>	Data Table
	Swept Graphs
	S-Parameter (S4P Files) Data Set (.zip file)
<b>Case Style</b>	DL1020 <i>Plastic package, exposed paddle lead finish: Matte-Tin</i>
<b>Tape &amp; Reel</b> Standard quantities available on reel	F68 <i>7" reels with 20, 50, 100, 200, 500 or 1K devices</i>
<b>Suggested Layout for PCB Design</b>	PL-322
<b>Evaluation Board</b>	TB-666-50-105+
<b>Environmental Ratings</b>	ENV08T2

## ESD Rating

Human Body Model (HBM): Class 1A (250 to <500V) in accordance with ANSI/ESD STM 5.1 - 2001  
Machine Model (MM): Class M1 (pass 25V) in accordance with ANSI/ESD STM5.2-1999

## MSL Rating

Moisture Sensitivity: MSL1 in accordance with IPC/JEDEC J-STD-020D

### MSL Test Flow Chart

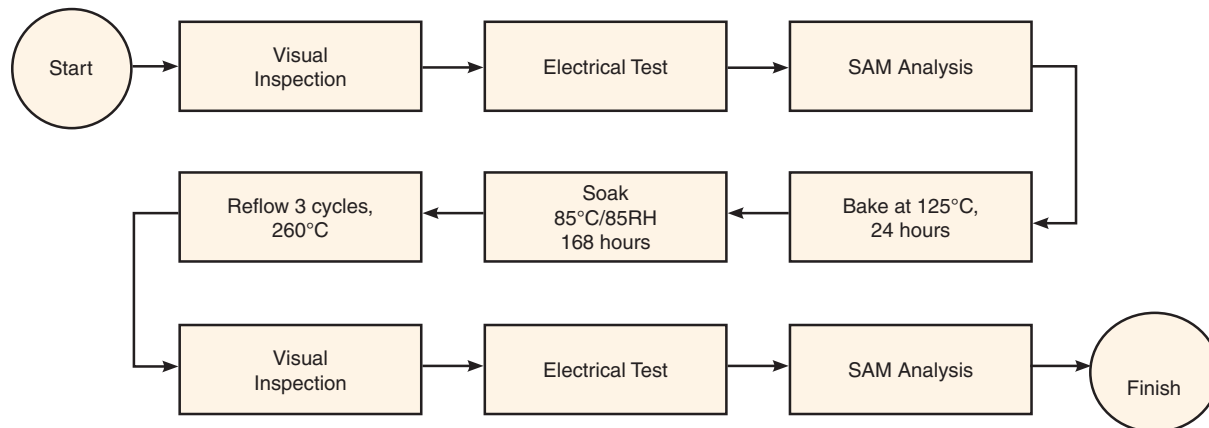

### Additional Notes

- Performance and quality attributes and conditions not expressly stated in this specification document are intended to be excluded and do not form a part of this specification document.
- Electrical specifications and performance data contained in this specification document are based on Mini-Circuit's applicable established test performance criteria and measurement instructions.
- The parts covered by this specification document are subject to Mini-Circuits standard limited warranty and terms and conditions (collectively, "Standard Terms"); Purchasers of this part are entitled to the rights and benefits contained therein. For a full statement of the Standard Terms and the exclusive rights and remedies thereunder, please visit Mini-Circuits' website at [www.minicircuits.com/MCLStore/terms.jsp](http://www.minicircuits.com/MCLStore/terms.jsp)

## Typical Performance Data

NOTE: Use PDF Bookmarks to view DATA at required conditions

## Definitions:

Input Return Loss = -S11 (dB)

Gain(Power Gain) = S21 (dB)

Reverse Isolation = -S12 (dB)

Output Return Loss = -S22 (dB)

TEST CONDITIONS: Vd = 5.00V, Id1 (A1) = 63.62 mA and Id2 (A2) = 64.19 mA @ Temperature = +25degC

FREQ	A1	A2	A1 & A2		A1							
	Gain		Amp Unbal	Phase Unbal	Isolation	Input Return Loss	Output Return Loss	Stability		IP-3 Output	1dB Comp. Output	Noise Figure
(MHz)	(dB)	(dB)	(dB)	(Deg)	(dB)	(dB)	(dB)	K	Measure	(dBm)	(dBm)	(dB)
10	20.03	20.04	0.01	0.01	23.33	3.00	4.37	0.42	0.69	--	20.37	--
20	17.93	17.95	0.02	0.05	20.15	6.43	7.71	0.68	0.61	36.92	21.06	1.43
30	16.69	16.70	0.01	0.01	19.46	9.21	10.57	0.84	0.61	37.51	21.45	1.64
40	16.02	16.03	0.01	0.02	19.16	11.40	12.84	0.93	0.61	36.25	21.08	1.64
50	15.63	15.64	0.01	0.02	19.10	13.16	14.75	0.98	0.61	36.11	20.91	1.68
60	15.38	15.39	0.01	0.01	18.83	14.59	16.12	1.01	0.60	38.34	21.19	1.66
70	15.22	15.23	0.01	0.02	18.91	15.82	17.63	1.04	0.61	38.53	21.22	1.65
80	15.11	15.12	0.01	0.02	18.88	16.84	18.80	1.05	0.61	37.61	21.09	1.72
90	15.04	15.05	0.01	0.02	18.86	17.72	19.81	1.06	0.61	38.44	21.05	1.75
100	14.98	14.99	0.01	0.04	18.85	18.51	20.83	1.07	0.61	38.18	21.09	1.78
200	14.78	14.79	0.01	0.10	18.85	22.94	26.33	1.10	0.61	39.82	20.81	1.82
300	14.72	14.73	0.01	0.15	18.85	24.66	25.85	1.11	0.62	39.68	20.96	1.94
400	14.67	14.69	0.02	0.20	18.95	25.46	23.27	1.12	0.62	42.60	21.04	1.97
500	14.64	14.67	0.03	0.25	18.98	25.36	21.31	1.12	0.62	39.85	21.14	2.00
600	14.61	14.64	0.03	0.27	19.06	24.82	19.50	1.13	0.63	40.35	20.92	1.97
700	14.57	14.62	0.05	0.31	19.17	24.07	17.94	1.13	0.63	38.84	21.03	1.88
800	14.54	14.59	0.05	0.34	19.29	23.22	16.60	1.14	0.64	39.11	21.07	1.89
1000	14.45	14.51	0.06	0.37	19.56	21.53	14.42	1.16	0.64	36.77	20.82	1.96
1100	14.40	14.48	0.08	0.35	19.71	20.88	13.51	1.16	0.65	37.88	20.80	1.88
1200	14.34	14.44	0.10	0.32	19.88	20.38	12.66	1.17	0.65	37.64	20.81	1.85
1300	14.29	14.40	0.11	0.26	20.06	20.00	11.92	1.18	0.66	36.72	20.60	1.89
1400	14.24	14.35	0.11	0.25	20.25	19.65	11.21	1.19	0.66	37.30	20.48	1.91
1500	14.18	14.31	0.13	0.20	20.43	19.49	10.57	1.19	0.66	36.96	20.46	1.89
1600	14.15	14.28	0.13	0.07	20.67	19.56	10.05	1.20	0.67	36.59	20.50	1.81
1700	14.11	14.26	0.15	0.01	20.85	19.59	9.53	1.20	0.67	35.80	20.08	1.81
1800	14.10	14.25	0.15	0.10	21.08	19.70	9.08	1.20	0.68	35.60	20.00	1.82
1900	14.10	14.25	0.15	0.27	21.33	19.76	8.68	1.20	0.69	35.35	19.92	1.77
2000	14.11	14.27	0.16	0.35	21.63	19.51	8.30	1.20	0.70	35.07	20.06	1.72
2100	14.15	14.30	0.15	0.61	22.00	18.86	8.00	1.20	0.71	34.14	20.12	1.71
2200	14.22	14.34	0.12	0.77	22.48	17.87	7.75	1.21	0.73	34.02	20.23	1.71
2300	14.29	14.39	0.10	0.80	23.14	16.59	7.54	1.24	0.75	33.57	19.93	1.70
2400	14.37	14.44	0.07	0.88	23.91	15.21	7.38	1.28	0.78	33.50	19.86	1.61
2500	14.47	14.51	0.04	0.95	25.09	13.83	7.32	1.39	0.81	34.01	20.12	1.65
2600	14.54	14.55	0.01	1.15	26.74	12.79	7.32	1.60	0.85	33.08	19.95	1.65
2700	14.60	14.57	0.03	0.81	29.50	11.90	7.54	2.13	0.88	32.81	19.99	1.67
2800	14.61	14.55	0.06	0.66	33.68	11.42	7.81	3.43	0.91	32.72	20.12	1.71
2900	14.54	14.49	0.05	0.42	40.34	11.37	8.26	7.62	0.92	32.92	20.24	1.70
3000	14.43	14.37	0.06	0.19	35.56	11.78	8.74	4.66	0.91	33.18	20.59	1.61

## Typical Performance Data

### Definitions:

Input Return Loss = -S11 (dB)

Gain(Power Gain) = S21 (dB)

Reverse Isolation = -S12 (dB)

Output Return Loss = -S22 (dB)

TEST CONDITIONS: Vd = 4.75V, Id1 (A1) = 60 mA and Id2 (A2) = 60.51 mA @ Temperature = +25degC

FREQ	A1		A2		A1 & A2		A1					
	Gain		Amp Unbal	Phase Unbal	Isolation	Input Return Loss	Output Return Loss	Stability		IP-3 Output	1dB Comp. Output	Noise Figure
(MHz)	(dB)	(dB)	(dB)	(Deg)	(dB)	(dB)	(dB)	K	Measure	(dBm)	(dBm)	(dB)
10	20.03	20.01	0.02	0.09	22.71	3.18	4.57	0.44	0.65	--	19.99	--
20	17.90	17.91	0.01	0.02	20.05	6.41	7.68	0.68	0.60	36.30	20.62	1.41
30	16.66	16.67	0.01	0.05	19.39	9.17	10.53	0.83	0.61	36.48	21.05	1.62
40	15.98	15.99	0.01	0.07	19.15	11.38	12.84	0.93	0.61	35.74	20.68	1.67
50	15.59	15.60	0.01	0.07	18.96	13.17	14.74	0.98	0.60	35.12	20.57	1.64
60	15.34	15.36	0.02	0.08	18.90	14.46	16.10	1.01	0.61	38.09	20.78	1.66
70	15.18	15.20	0.02	0.07	18.91	15.76	17.56	1.04	0.61	37.87	20.79	1.63
80	15.07	15.09	0.02	0.08	18.85	16.79	18.74	1.05	0.61	38.82	20.67	1.74
90	15.00	15.02	0.02	0.08	18.81	17.67	19.75	1.06	0.61	38.89	20.61	1.78
100	14.94	14.96	0.02	0.09	18.80	18.48	20.77	1.07	0.61	37.31	20.68	1.78
200	14.74	14.76	0.02	0.11	18.80	22.92	26.25	1.10	0.61	38.89	20.40	1.76
300	14.67	14.70	0.03	0.16	18.85	24.63	25.80	1.11	0.62	38.47	20.54	1.92
400	14.62	14.66	0.04	0.20	18.91	25.36	23.40	1.12	0.62	40.35	20.61	1.95
500	14.60	14.64	0.04	0.22	18.94	25.33	21.40	1.12	0.62	39.30	20.72	1.98
600	14.57	14.61	0.04	0.26	19.04	24.77	19.63	1.13	0.63	39.29	20.50	1.98
700	14.53	14.58	0.05	0.29	19.14	24.10	18.07	1.13	0.63	38.59	20.60	1.88
800	14.50	14.55	0.05	0.31	19.25	23.18	16.70	1.14	0.64	37.94	20.65	1.88
1000	14.41	14.48	0.07	0.32	19.51	21.56	14.54	1.16	0.65	35.61	20.35	1.97
1100	14.36	14.45	0.09	0.30	19.68	20.94	13.61	1.16	0.65	37.33	20.38	1.87
1200	14.31	14.41	0.10	0.27	19.84	20.44	12.76	1.17	0.65	36.76	20.38	1.88
1300	14.25	14.37	0.12	0.23	20.01	20.03	12.03	1.18	0.66	37.06	20.15	1.87
1400	14.20	14.32	0.12	0.20	20.23	19.70	11.32	1.19	0.66	36.79	20.03	1.89
1500	14.15	14.27	0.12	0.14	20.39	19.57	10.69	1.19	0.67	36.06	20.04	1.88
1600	14.11	14.25	0.14	0.02	20.60	19.65	10.16	1.20	0.67	35.98	20.07	1.81
1700	14.08	14.22	0.14	0.07	20.81	19.70	9.64	1.20	0.68	35.46	19.62	1.85
1800	14.07	14.21	0.14	0.16	21.04	19.86	9.18	1.20	0.68	35.22	19.55	1.84
1900	14.07	14.21	0.14	0.30	21.31	19.94	8.80	1.20	0.69	34.75	19.45	1.79
2000	14.08	14.23	0.15	0.38	21.61	19.73	8.42	1.20	0.70	34.65	19.61	1.70
2100	14.12	14.26	0.14	0.64	21.99	19.06	8.13	1.21	0.72	34.08	19.67	1.68
2200	14.19	14.30	0.11	0.80	22.48	18.07	7.87	1.22	0.73	33.72	19.79	1.70
2300	14.26	14.35	0.09	0.81	23.10	16.75	7.69	1.25	0.76	33.33	19.47	1.71
2400	14.34	14.40	0.06	0.88	23.94	15.39	7.53	1.30	0.78	33.20	19.40	1.61
2500	14.44	14.47	0.03	0.97	25.19	13.99	7.48	1.42	0.82	33.56	19.65	1.64
2600	14.51	14.51	0.00	1.14	26.87	12.92	7.50	1.65	0.85	32.66	19.49	1.61
2700	14.57	14.52	0.05	0.79	29.72	12.05	7.75	2.22	0.89	32.53	19.53	1.67
2800	14.57	14.51	0.06	0.64	34.19	11.53	8.05	3.70	0.91	32.23	19.69	1.64
2900	14.51	14.44	0.07	0.41	42.36	11.49	8.52	9.79	0.93	32.56	19.81	1.63
3000	14.40	14.32	0.08	0.14	35.74	11.92	9.03	4.84	0.92	32.92	20.14	1.53

## Typical Performance Data

## Definitions:

Input Return Loss = -S11 (dB)

Gain(Power Gain) = S21 (dB)

Reverse Isolation = -S12 (dB)

Output Return Loss = -S22 (dB)

TEST CONDITIONS: Vd = 5.25V, Id1 (A1) = 67.2mA and Id2 (A2) = 67.84 mA @ Temperature = +25degC

FREQ	A1	A2	A1 & A2		A1							
	Gain		Amp Unbal	Phase Unbal	Isolation	Input Return Loss	Output Return Loss	Stability		IP-3 Output	1dB Comp. Output	Noise Figure
(MHz)	(dB)	(dB)	(dB)	(Deg)	(dB)	(dB)	(dB)	K	Measure	(dBm)	(dBm)	(dB)
10	20.09	20.10	0.01	0.06	22.98	3.14	4.48	0.44	0.66	--	20.72	--
20	17.96	17.97	0.01	0.02	20.23	6.45	7.70	0.68	0.62	36.94	21.46	1.44
30	16.72	16.73	0.01	0.09	19.44	9.23	10.53	0.83	0.60	36.32	21.83	1.65
40	16.04	16.06	0.02	0.11	19.17	11.42	12.84	0.92	0.60	36.68	21.45	1.71
50	15.65	15.67	0.02	0.11	19.03	13.21	14.74	0.98	0.60	37.08	21.27	1.67
60	15.40	15.42	0.02	0.12	18.83	14.49	16.13	1.01	0.60	38.76	21.58	1.70
70	15.24	15.26	0.02	0.11	18.90	15.85	17.60	1.04	0.61	39.59	21.61	1.66
80	15.13	15.16	0.03	0.11	18.87	16.87	18.76	1.05	0.61	38.47	21.48	1.73
90	15.06	15.09	0.03	0.12	18.87	17.74	19.79	1.06	0.61	39.95	21.44	1.79
100	15.00	15.03	0.03	0.11	18.85	18.57	20.80	1.07	0.61	39.19	21.48	1.77
200	14.80	14.83	0.03	0.15	18.83	23.09	26.17	1.10	0.61	41.18	21.16	1.78
300	14.74	14.77	0.03	0.17	18.88	24.78	25.46	1.11	0.62	42.98	21.37	1.87
400	14.69	14.73	0.04	0.21	18.94	25.56	23.01	1.12	0.62	41.94	21.43	1.95
500	14.66	14.71	0.05	0.26	19.01	25.47	21.05	1.12	0.62	42.89	21.52	2.01
600	14.63	14.68	0.05	0.28	19.07	24.96	19.26	1.13	0.63	40.62	21.28	1.96
700	14.59	14.65	0.06	0.29	19.18	24.16	17.71	1.13	0.63	40.48	21.39	1.93
800	14.56	14.62	0.06	0.29	19.30	23.18	16.37	1.14	0.63	39.60	21.45	1.87
1000	14.47	14.55	0.08	0.32	19.56	21.48	14.20	1.15	0.64	37.23	21.17	1.95
1100	14.43	14.52	0.09	0.29	19.72	20.81	13.29	1.16	0.64	38.40	21.16	1.88
1200	14.37	14.47	0.10	0.26	19.89	20.28	12.46	1.17	0.65	37.81	21.18	1.86
1300	14.32	14.43	0.11	0.21	20.06	19.89	11.72	1.17	0.65	37.16	20.96	1.88
1400	14.26	14.38	0.12	0.16	20.29	19.52	11.01	1.18	0.66	37.95	20.85	1.93
1500	14.21	14.34	0.13	0.12	20.45	19.36	10.39	1.19	0.66	37.11	20.86	1.93
1600	14.18	14.32	0.14	0.00	20.65	19.40	9.85	1.19	0.66	37.10	20.89	1.86
1700	14.14	14.29	0.15	0.08	20.86	19.37	9.34	1.19	0.67	36.06	20.48	1.84
1800	14.13	14.28	0.15	0.18	21.09	19.48	8.87	1.19	0.67	36.11	20.38	1.88
1900	14.14	14.28	0.14	0.33	21.36	19.46	8.48	1.19	0.68	35.75	20.31	1.81
2000	14.15	14.30	0.15	0.41	21.58	19.19	8.09	1.18	0.69	35.94	20.46	1.76
2100	14.19	14.33	0.14	0.67	21.98	18.51	7.79	1.18	0.70	34.91	20.52	1.74
2200	14.26	14.36	0.10	0.83	22.46	17.51	7.52	1.19	0.72	34.62	20.63	1.72
2300	14.33	14.41	0.08	0.87	23.00	16.30	7.31	1.20	0.74	34.16	20.33	1.73
2400	14.41	14.46	0.05	0.89	23.83	14.98	7.13	1.25	0.77	33.99	20.21	1.65
2500	14.52	14.53	0.01	0.99	24.96	13.64	7.05	1.34	0.80	34.19	20.50	1.67
2600	14.59	14.58	0.01	1.14	26.57	12.60	7.03	1.53	0.83	33.48	20.33	1.66
2700	14.65	14.59	0.06	0.82	29.10	11.74	7.23	1.98	0.87	33.14	20.38	1.70
2800	14.66	14.58	0.08	0.65	32.99	11.24	7.47	3.08	0.90	33.20	20.54	1.71
2900	14.59	14.52	0.07	0.39	38.24	11.18	7.88	5.82	0.91	33.67	20.64	1.71
3000	14.49	14.40	0.09	0.12	35.16	11.57	8.32	4.33	0.90	33.66	20.98	1.60



## Typical Performance Data

## Definitions:

Input Return Loss = -S11 (dB)

Gain(Power Gain) = S21 (dB)

Reverse Isolation = -S12 (dB)

Output Return Loss = -S22 (dB)

TEST CONDITIONS: Vd = 5.00V, Id1 (A1) = 57.8 mA and Id2 (A2) = 56.62 mA @ Temperature = -45degC

FREQ	A1	A2	A1 & A2		A1							
	Gain		Amp Unbal	Phase Unbal	Isolation	Input Return Loss	Output Return Loss	Stability		IP-3 Output	1dB Comp. Output	Noise Figure
(MHz)	(dB)	(dB)	(dB)	(Deg)	(dB)	(dB)	(dB)	K	Measure	(dBm)	(dBm)	(dB)
10	20.14	20.15	0.01	0.28	22.75	2.90	4.15	0.38	0.67	--	20.23	--
20	17.93	17.93	0.00	0.16	19.73	6.01	7.06	0.61	0.61	35.99	20.91	1.13
30	16.50	16.48	0.02	0.13	18.92	8.68	9.64	0.78	0.61	37.41	21.23	1.28
40	15.67	15.65	0.02	0.11	18.63	10.83	11.68	0.88	0.61	35.90	20.58	1.34
50	15.16	15.14	0.02	0.11	18.42	12.58	13.34	0.95	0.60	35.77	20.61	1.38
60	14.84	14.82	0.02	0.06	18.24	13.93	14.48	0.99	0.60	37.29	20.99	1.38
70	14.63	14.60	0.03	0.03	18.29	15.20	15.67	1.02	0.61	37.35	21.03	1.34
80	14.49	14.46	0.03	0.01	18.26	16.26	16.61	1.04	0.61	37.73	20.83	1.46
90	14.39	14.36	0.03	0.01	18.22	17.20	17.40	1.05	0.61	38.60	20.84	1.51
100	14.32	14.28	0.04	0.03	18.22	18.04	18.17	1.07	0.61	40.31	20.87	1.50
200	14.06	14.02	0.04	0.12	18.18	23.14	20.71	1.11	0.61	42.56	20.46	1.54
300	13.99	13.96	0.03	0.22	18.23	23.77	19.34	1.11	0.61	41.98	20.72	1.62
400	13.95	13.93	0.02	0.30	18.29	23.36	18.22	1.12	0.61	40.28	20.99	1.67
500	13.95	13.93	0.02	0.34	18.34	23.05	17.17	1.12	0.61	42.16	21.08	1.73
600	13.95	13.94	0.01	0.40	18.43	22.45	16.09	1.12	0.61	39.34	20.71	1.71
700	13.95	13.95	0.00	0.44	18.55	21.66	15.02	1.12	0.61	38.37	20.97	1.62
800	13.96	13.97	0.01	0.47	18.66	20.89	14.04	1.13	0.61	36.74	20.97	1.56
1000	13.96	13.99	0.03	0.49	18.95	19.41	12.17	1.13	0.61	36.80	20.56	1.67
1100	13.97	14.02	0.05	0.50	19.12	18.71	11.36	1.13	0.61	36.73	20.71	1.58
1200	13.97	14.04	0.07	0.51	19.27	18.13	10.61	1.12	0.61	35.95	20.72	1.55
1300	13.99	14.08	0.09	0.45	19.46	17.70	9.90	1.12	0.60	35.39	20.43	1.60
1400	14.01	14.11	0.10	0.38	19.64	17.42	9.28	1.11	0.60	36.17	20.26	1.60
1500	14.04	14.15	0.11	0.34	19.83	17.21	8.73	1.10	0.60	35.25	20.29	1.56
1600	14.09	14.22	0.13	0.18	20.01	17.08	8.23	1.09	0.60	34.69	20.30	1.49
1700	14.15	14.29	0.14	0.10	20.20	17.01	7.74	1.07	0.60	34.50	19.70	1.48
1800	14.23	14.37	0.14	0.04	20.43	16.86	7.28	1.05	0.60	34.27	19.56	1.48
1900	14.32	14.46	0.14	0.20	20.71	16.73	6.88	1.03	0.60	34.20	19.49	1.43
2000	14.43	14.59	0.16	0.29	20.98	16.54	6.49	1.00	0.61	34.15	19.66	1.35
2100	14.56	14.71	0.15	0.60	21.29	15.91	6.19	0.98	0.62	33.56	19.74	1.33
2200	14.72	14.84	0.12	0.82	21.77	15.11	5.94	0.96	0.64	33.58	19.90	1.31
2300	14.87	14.97	0.10	0.89	22.32	14.09	5.75	0.95	0.67	33.66	19.62	1.38
2400	15.00	15.08	0.08	0.97	23.07	12.92	5.59	0.95	0.70	33.54	19.54	1.24
2500	15.15	15.19	0.04	1.10	24.12	11.75	5.52	0.98	0.74	34.20	19.91	1.27
2600	15.25	15.27	0.02	1.37	25.53	10.96	5.48	1.08	0.77	33.42	19.80	1.25
2700	15.34	15.30	0.04	1.03	27.72	10.30	5.63	1.33	0.81	33.71	19.89	1.27
2800	15.37	15.31	0.06	0.95	30.57	10.02	5.79	1.83	0.84	33.98	20.11	1.29
2900	15.33	15.25	0.08	0.72	34.62	10.01	6.15	3.05	0.85	34.01	20.26	1.28
3000	15.25	15.16	0.09	0.43	35.19	10.32	6.58	3.51	0.85	34.66	20.66	1.17

## Typical Performance Data

**Definitions:**

Input Return Loss = -S11 (dB)

Gain(Power Gain) = S21 (dB)

Reverse Isolation = -S12 (dB)

Output Return Loss = -S22 (dB)

TEST CONDITIONS: Vd = 4.75V, Id1 (A1) = 54.69 mA and Id2 (A2) = 53.72 mA @ Temperature = -45degC

FREQ	A1		A2		A1 & A2		A1					
	Gain		Amp Unbal	Phase Unbal	Isolation	Input Return Loss	Output Return Loss	Stability		IP-3 Output	1dB Comp. Output	Noise Figure
	(MHz)	(dB)	(dB)	(dB)	(Deg)	(dB)	(dB)	(dB)	K	Measure	(dBm)	(dBm)
10	20.10	20.10	0.00	0.06	21.98	2.82	4.14	0.43	0.53	--	19.76	--
20	17.90	17.90	0.00	0.21	19.72	5.98	7.04	0.61	0.61	34.83	20.42	1.10
30	16.47	16.45	0.02	0.18	18.87	8.68	9.66	0.78	0.60	36.15	20.78	1.28
40	15.64	15.62	0.02	0.14	18.58	10.81	11.71	0.88	0.61	35.62	20.13	1.35
50	15.14	15.11	0.03	0.13	18.33	12.58	13.38	0.95	0.60	35.56	20.12	1.36
60	14.82	14.79	0.03	0.09	18.38	13.80	14.50	0.99	0.61	37.19	20.48	1.38
70	14.61	14.58	0.03	0.07	18.30	15.20	15.74	1.02	0.61	37.87	20.55	1.32
80	14.47	14.43	0.04	0.05	18.26	16.27	16.66	1.04	0.61	36.33	20.32	1.44
90	14.37	14.33	0.04	0.03	18.24	17.20	17.48	1.06	0.61	39.03	20.32	1.51
100	14.30	14.25	0.05	0.01	18.20	18.05	18.25	1.07	0.61	37.99	20.35	1.52
200	14.04	14.00	0.04	0.12	18.17	23.34	20.95	1.11	0.61	40.88	20.00	1.49
300	13.97	13.93	0.04	0.21	18.22	23.98	19.58	1.12	0.61	43.53	20.26	1.65
400	13.94	13.90	0.04	0.31	18.28	23.60	18.40	1.12	0.61	41.55	20.46	1.69
500	13.93	13.91	0.02	0.37	18.33	23.22	17.35	1.12	0.61	44.76	20.56	1.75
600	13.93	13.91	0.02	0.43	18.41	22.61	16.23	1.12	0.61	39.71	20.23	1.68
700	13.93	13.92	0.01	0.50	18.56	21.86	15.16	1.13	0.62	38.40	20.47	1.61
800	13.94	13.94	0.00	0.53	18.64	21.07	14.17	1.13	0.61	37.16	20.48	1.59
1000	13.94	13.96	0.02	0.58	18.94	19.60	12.27	1.13	0.61	35.98	20.04	1.69
1100	13.95	13.99	0.04	0.61	19.10	18.87	11.44	1.13	0.61	36.95	20.24	1.61
1200	13.95	14.02	0.07	0.61	19.25	18.31	10.69	1.12	0.61	35.74	20.23	1.56
1300	13.96	14.05	0.09	0.53	19.44	17.86	9.99	1.12	0.61	35.56	19.93	1.56
1400	13.99	14.08	0.09	0.46	19.62	17.59	9.36	1.11	0.60	35.91	19.80	1.59
1500	14.02	14.12	0.10	0.45	19.80	17.37	8.80	1.11	0.60	35.20	19.79	1.54
1600	14.07	14.19	0.12	0.31	20.04	17.26	8.31	1.10	0.60	34.60	19.81	1.49
1700	14.12	14.26	0.14	0.21	20.18	17.18	7.82	1.08	0.60	34.68	19.24	1.46
1800	14.19	14.34	0.15	0.11	20.42	17.05	7.36	1.06	0.60	34.39	19.07	1.51
1900	14.29	14.44	0.15	0.08	20.68	16.95	6.96	1.04	0.60	34.15	19.01	1.44
2000	14.39	14.56	0.17	0.13	20.95	16.75	6.57	1.01	0.61	34.06	19.22	1.33
2100	14.52	14.68	0.16	0.45	21.33	16.13	6.27	0.99	0.62	33.42	19.29	1.31
2200	14.68	14.81	0.13	0.66	21.76	15.30	6.02	0.97	0.64	33.51	19.45	1.31
2300	14.83	14.94	0.11	0.76	22.36	14.24	5.83	0.96	0.67	33.31	19.14	1.40
2400	14.96	15.04	0.08	0.83	23.12	13.06	5.68	0.97	0.70	33.31	19.09	1.26
2500	15.11	15.16	0.05	0.97	24.13	11.86	5.61	1.00	0.74	33.75	19.46	1.27
2600	15.21	15.24	0.03	1.21	25.53	11.08	5.57	1.10	0.78	33.07	19.35	1.24
2700	15.29	15.27	0.02	0.88	27.79	10.40	5.72	1.37	0.82	33.11	19.44	1.29
2800	15.32	15.27	0.05	0.80	30.82	10.11	5.89	1.92	0.84	33.29	19.69	1.30
2900	15.28	15.22	0.06	0.56	35.03	10.11	6.25	3.25	0.86	33.47	19.83	1.26
3000	15.20	15.12	0.08	0.28	35.49	10.41	6.70	3.69	0.86	33.81	20.22	1.16

## Typical Performance Data

### Definitions:

Input Return Loss = -S11 (dB)

Gain(Power Gain) = S21 (dB)

Reverse Isolation = -S12 (dB)

Output Return Loss = -S22 (dB)

TEST CONDITIONS: Vd =5.25V, Id1 (A1) = 61.47 mA and Id2 (A2) =60.5 mA @ Temperature = -45degC

FREQ	A1		A2		A1 & A2		A1					
	Gain		Amp Unbal	Phase Unbal	Isolation	Input Return Loss	Output Return Loss	Stability		IP-3 Output	1dB Comp. Output	Noise Figure
	(MHz)	(dB)	(dB)	(Deg)	(dB)	(dB)	(dB)	K	Measure	(dBm)	(dBm)	(dB)
10	20.18	20.16	0.02	0.11	22.86	2.92	4.17	0.37	0.68	--	20.77	--
20	17.97	17.97	0.00	0.20	19.68	6.01	7.06	0.62	0.59	35.05	21.39	1.16
30	16.54	16.53	0.01	0.14	18.93	8.73	9.68	0.78	0.60	38.72	21.74	1.31
40	15.71	15.69	0.02	0.11	18.66	10.86	11.73	0.88	0.61	36.46	21.17	1.36
50	15.21	15.19	0.02	0.09	18.49	12.62	13.37	0.95	0.60	36.88	21.01	1.35
60	14.89	14.87	0.02	0.08	18.28	13.95	14.49	0.99	0.60	37.63	21.47	1.39
70	14.68	14.66	0.02	0.07	18.32	15.24	15.69	1.02	0.60	40.23	21.52	1.35
80	14.54	14.51	0.03	0.06	18.30	16.28	16.60	1.04	0.61	37.18	21.34	1.46
90	14.44	14.42	0.02	0.03	18.26	17.22	17.39	1.05	0.60	39.83	21.31	1.54
100	14.37	14.34	0.03	0.01	18.25	18.08	18.15	1.07	0.61	40.86	21.39	1.52
200	14.11	14.08	0.03	0.09	18.21	23.15	20.67	1.10	0.61	42.50	21.00	1.53
300	14.04	14.01	0.03	0.17	18.26	23.67	19.30	1.11	0.61	41.97	21.36	1.66
400	14.01	13.99	0.02	0.24	18.37	23.26	18.14	1.12	0.61	39.23	21.48	1.71
500	14.00	13.99	0.01	0.30	18.42	22.90	17.13	1.12	0.61	40.26	21.58	1.72
600	14.00	14.00	0.00	0.35	18.50	22.30	16.05	1.12	0.61	38.18	21.27	1.68
700	14.00	14.01	0.01	0.40	18.57	21.55	14.99	1.12	0.61	37.67	21.47	1.63
800	14.01	14.03	0.02	0.42	18.71	20.77	14.02	1.13	0.61	36.82	21.52	1.64
1000	14.01	14.04	0.03	0.46	19.01	19.33	12.12	1.13	0.61	36.98	21.19	1.64
1100	14.02	14.07	0.05	0.47	19.16	18.64	11.33	1.13	0.61	36.66	21.23	1.59
1200	14.02	14.09	0.07	0.44	19.31	18.04	10.57	1.12	0.61	35.62	21.28	1.60
1300	14.03	14.13	0.10	0.38	19.50	17.59	9.87	1.12	0.60	35.76	21.00	1.55
1400	14.06	14.16	0.10	0.32	19.67	17.33	9.25	1.11	0.60	35.89	20.80	1.60
1500	14.09	14.20	0.11	0.27	19.87	17.09	8.70	1.10	0.60	35.37	20.82	1.57
1600	14.14	14.26	0.12	0.15	20.04	16.96	8.20	1.09	0.60	34.49	20.84	1.49
1700	14.19	14.33	0.14	0.05	20.25	16.86	7.71	1.07	0.60	34.74	20.27	1.49
1800	14.26	14.41	0.15	0.07	20.47	16.71	7.26	1.05	0.60	34.32	20.12	1.52
1900	14.36	14.50	0.14	0.28	20.71	16.57	6.85	1.03	0.60	34.47	20.05	1.46
2000	14.46	14.62	0.16	0.34	20.95	16.41	6.46	1.00	0.60	34.23	20.19	1.32
2100	14.59	14.75	0.16	0.64	21.33	15.76	6.16	0.98	0.62	33.69	20.27	1.33
2200	14.75	14.88	0.13	0.85	21.76	14.97	5.91	0.95	0.64	33.40	20.42	1.29
2300	14.90	15.00	0.10	0.94	22.30	13.99	5.71	0.94	0.66	33.61	20.10	1.38
2400	15.03	15.11	0.08	1.02	23.05	12.81	5.56	0.94	0.70	33.87	19.98	1.24
2500	15.18	15.22	0.04	1.14	24.11	11.66	5.48	0.97	0.74	34.02	20.40	1.28
2600	15.28	15.30	0.02	1.40	25.47	10.89	5.44	1.06	0.77	33.86	20.27	1.27
2700	15.37	15.34	0.03	1.07	27.64	10.22	5.58	1.31	0.81	33.94	20.35	1.27
2800	15.40	15.33	0.07	0.97	30.50	9.94	5.74	1.80	0.83	34.27	20.57	1.28
2900	15.36	15.29	0.07	0.74	34.40	9.92	6.10	2.94	0.85	34.44	20.75	1.28
3000	15.27	15.19	0.08	0.48	35.05	10.22	6.52	3.42	0.85	35.24	21.16	1.13

## Typical Performance Data

### Definitions:

Input Return Loss = -S11 (dB)

Gain(Power Gain) = S21 (dB)

Reverse Isolation = -S12 (dB)

Output Return Loss = -S22 (dB)

TEST CONDITIONS: Vd = 5.00V, Id1(A1) = 67.87 mA and Id2 (A2) = 68.1 mA @ Temperature = +85degC

FREQ	A1	A2	A1 & A2		A1							
	Gain		Amp Unbal	Phase Unbal	Isolation	Input Return Loss	Output Return Loss	Stability		IP-3 Output	1dB Comp. Output	Noise Figure
(MHz)	(dB)	(dB)	(dB)	(Deg)	(dB)	(dB)	(dB)	K	Measure	(dBm)	(dBm)	(dB)
10	19.89	19.92	0.03	0.07	22.42	3.28	4.62	0.50	0.56	--	20.15	--
20	17.89	17.89	0.00	0.11	20.40	6.63	8.04	0.72	0.61	37.06	20.73	1.67
30	16.78	16.78	0.00	0.04	19.69	9.37	10.99	0.87	0.60	37.05	21.06	1.87
40	16.20	16.21	0.01	0.01	19.51	11.47	13.42	0.95	0.61	36.52	20.70	1.91
50	15.88	15.88	0.00	0.01	19.28	13.13	15.39	0.99	0.60	37.53	20.58	1.90
60	15.67	15.68	0.01	0.03	19.42	14.27	16.96	1.03	0.62	38.76	20.81	1.90
70	15.54	15.55	0.01	0.03	19.28	15.44	18.64	1.05	0.61	38.41	20.86	1.85
80	15.46	15.46	0.00	0.03	19.24	16.27	19.98	1.06	0.61	37.54	20.71	1.93
90	15.40	15.40	0.00	0.04	19.24	16.99	21.24	1.07	0.61	39.29	20.67	2.00
100	15.35	15.35	0.00	0.04	19.21	17.63	22.49	1.07	0.61	38.02	20.72	1.99
200	15.17	15.17	0.00	0.09	19.24	20.44	33.01	1.10	0.62	39.00	20.46	1.99
300	15.10	15.11	0.01	0.13	19.31	20.73	36.05	1.11	0.63	39.60	20.54	2.10
400	15.04	15.06	0.02	0.13	19.28	21.10	29.04	1.12	0.63	40.08	20.61	2.15
500	15.00	15.03	0.03	0.13	19.38	21.40	25.29	1.12	0.64	39.05	20.68	2.24
600	14.96	14.98	0.02	0.16	19.42	21.43	22.67	1.13	0.64	38.91	20.46	2.17
700	14.90	14.93	0.03	0.15	19.51	21.43	20.68	1.14	0.65	38.23	20.58	2.14
800	14.84	14.88	0.04	0.15	19.61	21.49	19.00	1.15	0.65	38.88	20.60	2.13
1000	14.69	14.75	0.06	0.11	19.88	21.07	16.41	1.17	0.67	36.57	20.29	2.24
1100	14.61	14.68	0.07	0.07	20.03	20.78	15.28	1.18	0.67	37.70	20.27	2.11
1200	14.51	14.60	0.09	0.01	20.20	20.51	14.25	1.20	0.68	38.82	20.35	2.12
1300	14.42	14.51	0.09	0.03	20.38	20.26	13.39	1.21	0.69	37.72	20.19	2.15
1400	14.31	14.42	0.11	0.10	20.57	19.97	12.56	1.23	0.70	37.76	20.10	2.19
1500	14.21	14.32	0.11	0.18	20.76	19.91	11.84	1.24	0.70	37.18	20.09	2.14
1600	14.12	14.25	0.13	0.33	20.98	20.08	11.21	1.26	0.71	37.31	20.16	2.12
1700	14.03	14.17	0.14	0.42	21.17	20.25	10.63	1.27	0.71	36.49	19.78	2.14
1800	13.96	14.10	0.14	0.53	21.39	20.75	10.15	1.28	0.72	36.31	19.71	2.11
1900	13.91	14.05	0.14	0.72	21.67	21.46	9.75	1.30	0.73	36.18	19.65	2.09
2000	13.87	14.02	0.15	0.83	21.94	21.84	9.37	1.31	0.74	35.97	19.75	2.00
2100	13.86	14.00	0.14	1.11	22.30	21.56	9.08	1.33	0.75	35.01	19.79	1.99
2200	13.88	13.98	0.10	1.29	22.73	20.45	8.85	1.35	0.77	34.80	19.88	2.02
2300	13.90	13.99	0.09	1.34	23.37	18.66	8.65	1.40	0.79	34.25	19.57	2.04
2400	13.93	14.00	0.07	1.44	24.21	16.77	8.50	1.47	0.82	33.74	19.49	1.98
2500	14.00	14.04	0.04	1.54	25.40	14.97	8.45	1.61	0.85	33.88	19.66	2.03
2600	14.04	14.06	0.02	1.72	27.13	13.65	8.44	1.88	0.88	33.19	19.50	2.01
2700	14.09	14.06	0.03	1.46	30.05	12.56	8.66	2.56	0.91	32.58	19.61	2.06
2800	14.09	14.04	0.05	1.36	34.50	12.02	8.90	4.24	0.93	32.48	19.72	2.12
2900	14.02	13.97	0.05	1.15	41.26	11.96	9.31	9.48	0.94	32.63	19.85	2.06
3000	13.92	13.85	0.07	0.97	34.65	12.51	9.71	4.65	0.93	32.57	20.20	2.00

## Typical Performance Data

**Definitions:**

Input Return Loss = -S11 (dB)

Gain(Power Gain) = S21 (dB)

Reverse Isolation = -S12 (dB)

Output Return Loss = -S22 (dB)

TEST CONDITIONS: Vd = 4.75V, Id1(A1) = 64.12 mA and Id2 (A2) = 64.28 mA @ Temperature = +85degC

FREQ	A1	A2	A1 & A2		A1							
	Gain		Amp Unbal	Phase Unbal	Isolation	Input Return Loss	Output Return Loss	Stability		IP-3 Output	1dB Comp. Output	Noise Figure
(MHz)	(dB)	(dB)	(dB)	(Deg)	(dB)	(dB)	(dB)	K	Measure	(dBm)	(dBm)	(dB)
10	19.87	19.87	0.00	0.12	22.32	3.06	4.61	0.51	0.54	--	19.76	--
20	17.86	17.86	0.00	0.08	20.43	6.61	8.04	0.72	0.62	34.43	20.39	1.65
30	16.75	16.75	0.00	0.02	19.77	9.34	10.98	0.87	0.61	36.06	20.75	1.81
40	16.17	16.17	0.00	0.03	19.45	11.42	13.40	0.95	0.61	37.86	20.41	1.89
50	15.84	15.85	0.01	0.04	19.27	13.02	15.37	1.00	0.60	36.01	20.24	1.85
60	15.64	15.64	0.00	0.03	19.42	14.34	16.92	1.03	0.63	38.09	20.49	1.90
70	15.50	15.51	0.01	0.04	19.27	15.38	18.57	1.05	0.61	37.79	20.53	1.84
80	15.42	15.42	0.00	0.03	19.24	16.21	19.93	1.06	0.61	37.84	20.41	1.95
90	15.35	15.36	0.01	0.04	19.22	16.92	21.17	1.07	0.61	38.06	20.35	1.97
100	15.31	15.31	0.00	0.04	19.19	17.53	22.38	1.08	0.61	37.30	20.39	1.97
200	15.13	15.14	0.01	0.04	19.20	20.26	32.42	1.10	0.62	37.67	20.14	1.98
300	15.06	15.08	0.02	0.07	19.23	20.58	35.94	1.11	0.63	37.68	20.25	2.16
400	15.00	15.02	0.02	0.06	19.28	20.98	29.51	1.12	0.63	39.58	20.31	2.18
500	14.96	14.99	0.03	0.06	19.34	21.21	25.62	1.12	0.64	38.53	20.36	2.24
600	14.91	14.95	0.04	0.04	19.43	21.28	23.02	1.13	0.64	37.72	20.17	2.17
700	14.86	14.90	0.04	0.03	19.48	21.28	20.97	1.14	0.65	37.68	20.26	2.10
800	14.80	14.85	0.05	0.00	19.58	21.36	19.27	1.15	0.65	38.62	20.28	2.12
1000	14.65	14.72	0.07	0.05	19.85	20.98	16.66	1.17	0.67	36.21	19.99	2.21
1100	14.57	14.64	0.07	0.10	19.98	20.73	15.49	1.18	0.68	37.28	19.97	2.08
1200	14.47	14.56	0.09	0.16	20.18	20.50	14.45	1.20	0.69	37.47	20.03	2.12
1300	14.38	14.48	0.10	0.25	20.34	20.23	13.61	1.21	0.69	36.90	19.88	2.11
1400	14.28	14.38	0.10	0.32	20.52	19.97	12.76	1.23	0.70	36.96	19.77	2.18
1500	14.17	14.28	0.11	0.39	20.71	19.90	12.02	1.24	0.70	36.64	19.79	2.16
1600	14.09	14.21	0.12	0.57	20.93	20.10	11.40	1.26	0.71	36.67	19.81	2.09
1700	13.99	14.13	0.14	0.66	21.13	20.33	10.83	1.27	0.72	35.81	19.46	2.10
1800	13.93	14.07	0.14	0.78	21.35	20.87	10.34	1.29	0.72	35.54	19.39	2.10
1900	13.88	14.01	0.13	0.96	21.62	21.62	9.94	1.30	0.73	35.25	19.32	2.07
2000	13.84	13.98	0.14	1.09	21.88	22.15	9.57	1.31	0.74	35.08	19.44	1.98
2100	13.83	13.96	0.13	1.37	22.30	21.95	9.30	1.34	0.76	34.51	19.48	2.01
2200	13.85	13.95	0.10	1.57	22.78	20.84	9.07	1.37	0.77	33.70	19.53	2.00
2300	13.87	13.96	0.09	1.65	23.40	18.96	8.90	1.42	0.80	33.71	19.25	2.02
2400	13.91	13.97	0.06	1.72	24.29	17.01	8.76	1.50	0.82	33.03	19.16	1.92
2500	13.98	14.01	0.03	1.80	25.54	15.17	8.73	1.66	0.86	33.14	19.33	2.01
2600	14.02	14.03	0.01	1.99	27.30	13.83	8.77	1.96	0.89	32.24	19.16	1.97
2700	14.06	14.03	0.03	1.73	30.31	12.72	9.01	2.69	0.92	32.13	19.26	2.03
2800	14.06	14.00	0.06	1.62	35.53	12.17	9.30	4.88	0.94	31.78	19.39	2.06
2900	13.99	13.94	0.05	1.44	45.15	12.14	9.75	15.16	0.95	31.91	19.53	2.03
3000	13.88	13.82	0.06	1.27	34.54	12.72	10.20	4.69	0.94	31.93	19.82	1.89

## Typical Performance Data

**Definitions:**

Input Return Loss = -S11 (dB)

Gain(Power Gain) = S21 (dB)

Reverse Isolation = -S12 (dB)

Output Return Loss = -S22 (dB)

TEST CONDITIONS: Vd = 5.25V, Id1(A1) = 71.57 mA and Id2 (A2) = 71.94 mA @ Temperature = +85degC

FREQ	A1		A2		A1 & A2		A1					
	Gain		Amp Unbal	Phase Unbal	Isolation	Input Return Loss	Output Return Loss	Stability		IP-3 Output	1dB Comp. Output	Noise Figure
	(MHz)	(dB)	(dB)	(Deg)	(dB)	(dB)	(dB)	K	Measure	(dBm)	(dBm)	(dB)
10	19.92	19.94	0.02	0.32	22.48	3.20	4.50	0.52	0.52	--	20.51	--
20	17.91	17.92	0.01	0.07	20.48	6.65	8.04	0.72	0.61	36.17	21.06	1.70
30	16.81	16.81	0.00	0.02	19.70	9.39	11.00	0.87	0.60	36.71	21.33	1.84
40	16.23	16.24	0.01	0.02	19.46	11.51	13.40	0.95	0.60	36.31	20.93	1.91
50	15.91	15.91	0.00	0.04	19.34	13.15	15.40	1.00	0.60	38.59	20.85	1.92
60	15.70	15.71	0.01	0.06	19.43	14.29	16.97	1.03	0.62	38.45	21.08	1.91
70	15.58	15.58	0.00	0.06	19.31	15.47	18.70	1.05	0.61	38.19	21.12	1.88
80	15.49	15.49	0.00	0.05	19.29	16.34	20.06	1.06	0.61	37.91	20.94	1.94
90	15.43	15.43	0.00	0.07	19.26	17.05	21.30	1.07	0.61	38.89	20.93	1.97
100	15.38	15.38	0.00	0.07	19.25	17.69	22.58	1.08	0.61	38.58	20.98	1.99
200	15.20	15.21	0.01	0.12	19.25	20.55	33.56	1.10	0.62	39.28	20.71	2.00
300	15.14	15.15	0.01	0.14	19.26	20.90	35.63	1.11	0.62	40.37	20.80	2.16
400	15.08	15.10	0.02	0.16	19.32	21.27	28.61	1.12	0.63	40.11	20.87	2.16
500	15.04	15.06	0.02	0.18	19.41	21.55	24.95	1.12	0.63	40.22	20.94	2.24
600	14.99	15.02	0.03	0.20	19.42	21.59	22.38	1.13	0.64	41.74	20.71	2.21
700	14.93	14.97	0.04	0.20	19.54	21.54	20.42	1.14	0.64	39.80	20.84	2.11
800	14.87	14.92	0.05	0.20	19.65	21.62	18.76	1.15	0.65	40.14	20.87	2.10
1000	14.72	14.78	0.06	0.18	19.91	21.13	16.19	1.17	0.67	37.55	20.54	2.19
1100	14.64	14.71	0.07	0.12	20.07	20.81	15.07	1.18	0.67	39.24	20.51	2.12
1200	14.54	14.63	0.09	0.07	20.22	20.53	14.06	1.19	0.68	38.32	20.60	2.16
1300	14.44	14.54	0.10	0.02	20.41	20.22	13.22	1.21	0.69	38.39	20.45	2.19
1400	14.34	14.45	0.11	0.03	20.57	19.95	12.39	1.22	0.69	38.03	20.34	2.20
1500	14.24	14.35	0.11	0.09	20.79	19.87	11.67	1.24	0.70	38.19	20.36	2.18
1600	14.15	14.27	0.12	0.23	20.98	20.00	11.06	1.25	0.70	37.97	20.43	2.16
1700	14.05	14.19	0.14	0.33	21.16	20.20	10.47	1.26	0.71	37.02	20.05	2.12
1800	13.99	14.12	0.13	0.44	21.43	20.64	9.98	1.28	0.72	37.09	20.00	2.13
1900	13.93	14.07	0.14	0.62	21.67	21.24	9.58	1.29	0.72	36.45	19.90	2.14
2000	13.90	14.04	0.14	0.71	21.95	21.64	9.21	1.30	0.73	36.19	20.01	2.03
2100	13.88	14.01	0.13	1.00	22.30	21.29	8.90	1.31	0.74	35.57	20.07	2.03
2200	13.90	14.00	0.10	1.17	22.76	20.22	8.66	1.34	0.76	35.00	20.16	2.06
2300	13.92	14.01	0.09	1.24	23.37	18.44	8.46	1.38	0.78	34.74	19.85	2.04
2400	13.96	14.02	0.06	1.30	24.18	16.62	8.29	1.45	0.81	34.43	19.77	1.99
2500	14.03	14.06	0.03	1.39	25.35	14.85	8.22	1.58	0.84	34.52	19.94	2.02
2600	14.07	14.08	0.01	1.54	27.05	13.54	8.19	1.84	0.87	33.65	19.78	2.02
2700	14.11	14.08	0.03	1.30	29.72	12.48	8.38	2.43	0.91	33.59	19.87	2.09
2800	14.12	14.05	0.07	1.18	33.98	11.92	8.60	3.93	0.93	33.31	19.97	2.13
2900	14.05	13.99	0.06	0.96	39.30	11.87	8.97	7.43	0.93	33.29	20.12	2.14
3000	13.95	13.87	0.08	0.77	34.35	12.41	9.34	4.42	0.92	33.40	20.49	2.04

## Typical Performance Curves

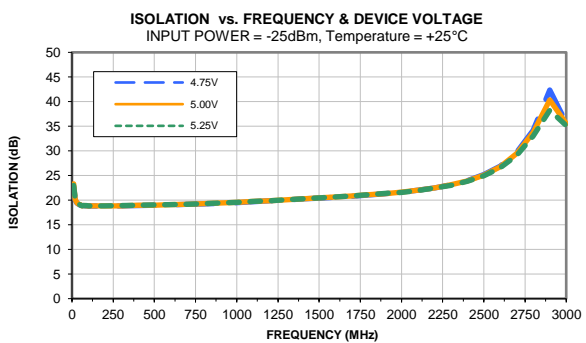
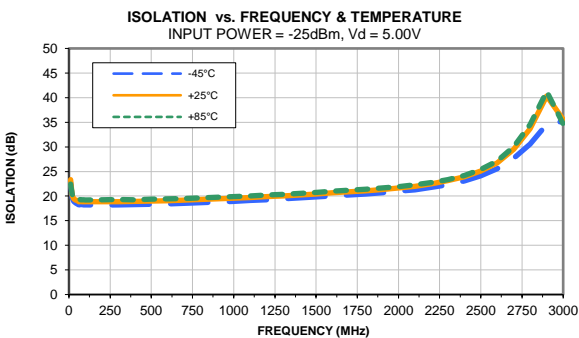
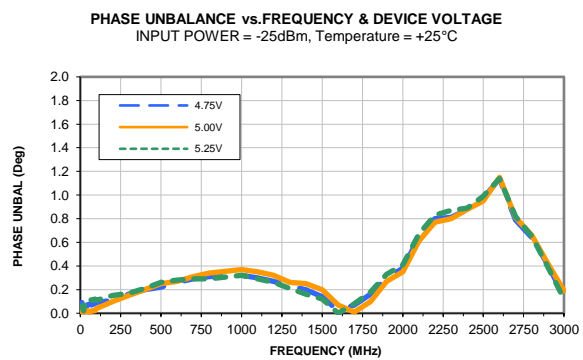
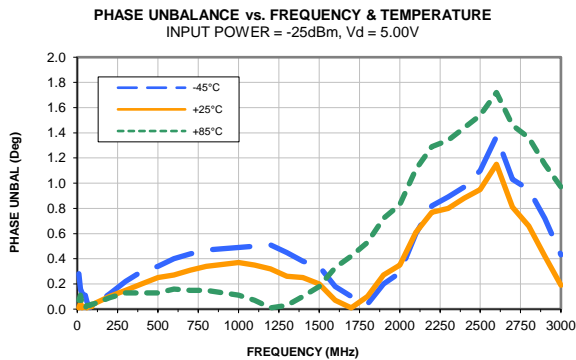
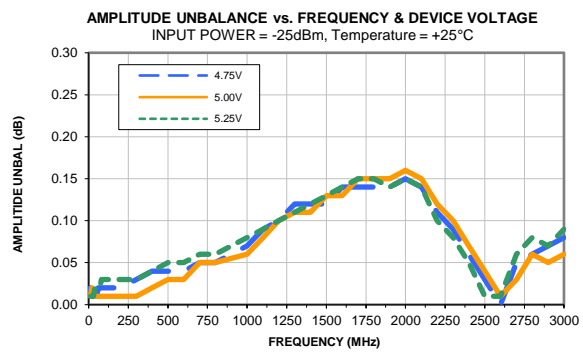
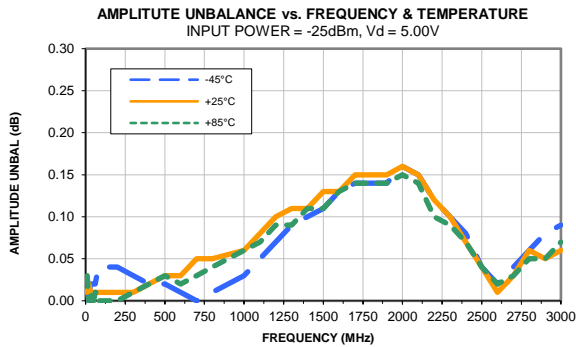
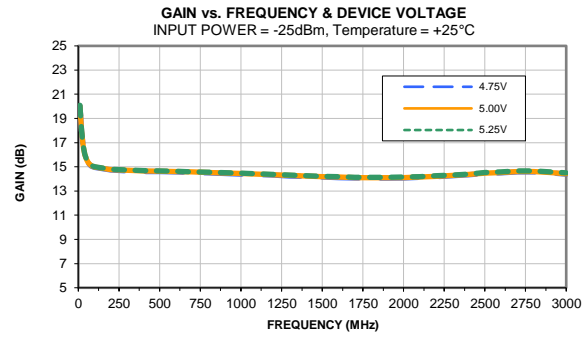
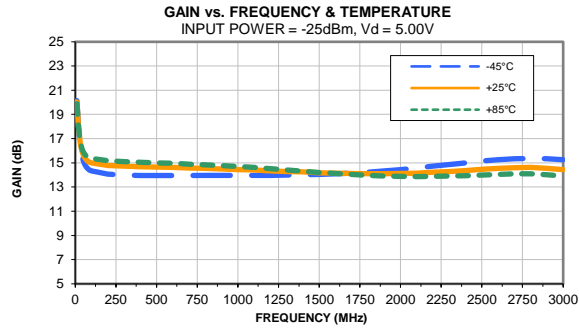

## Typical Performance Curves

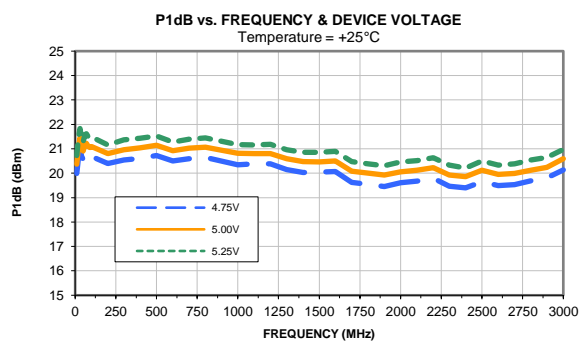
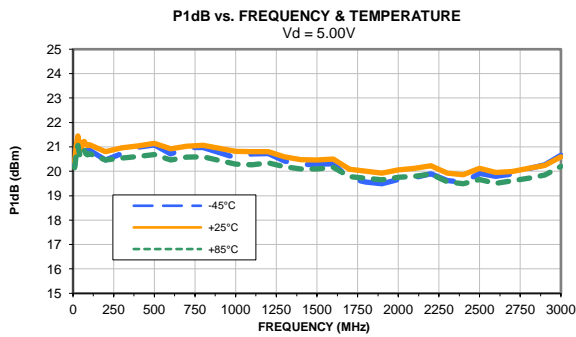
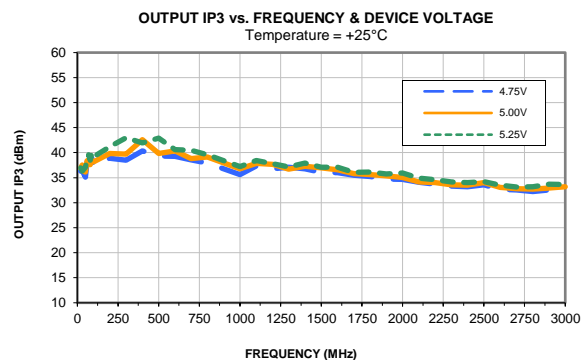
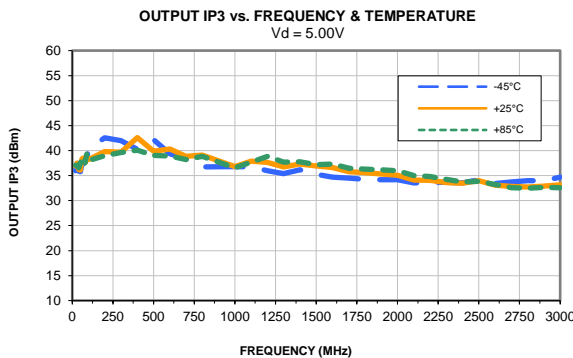
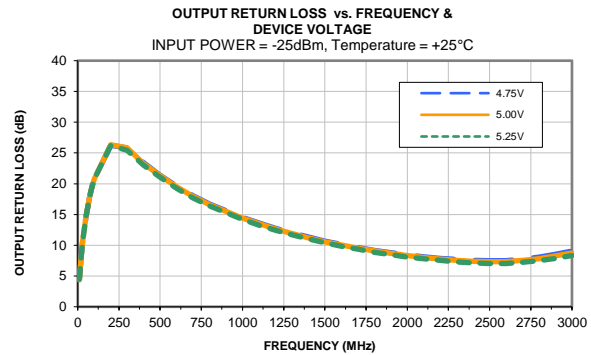
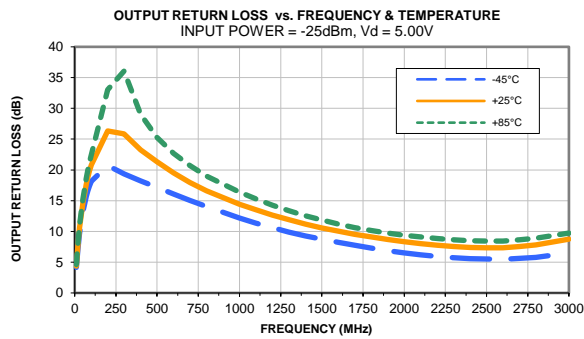
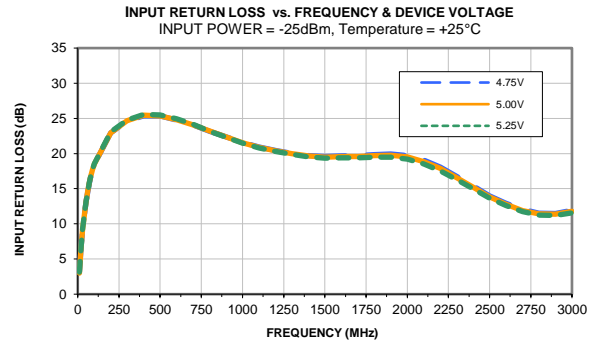
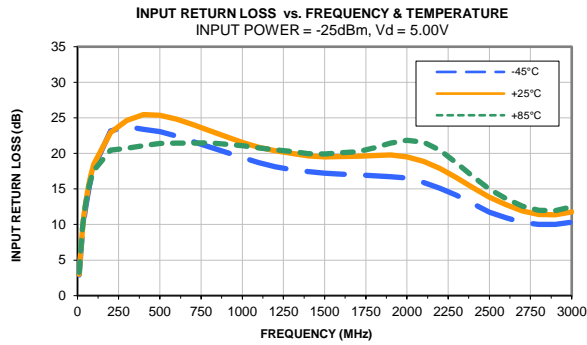



## Typical Performance Curves

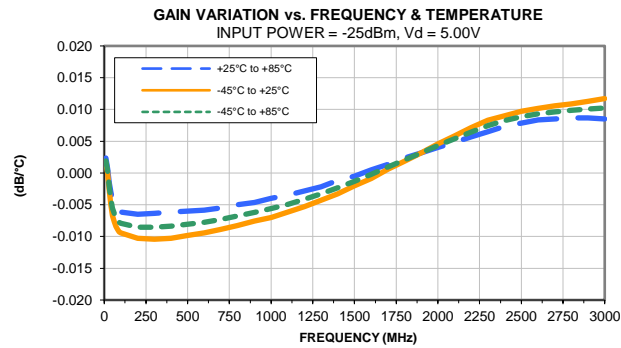
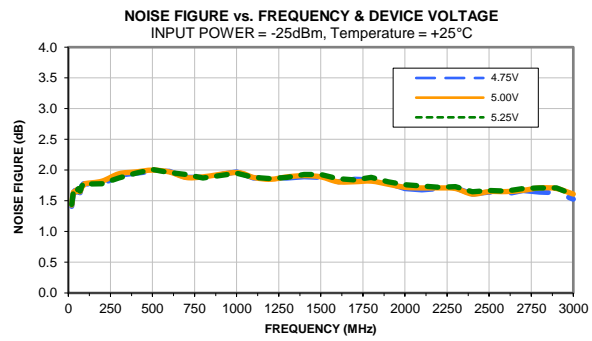
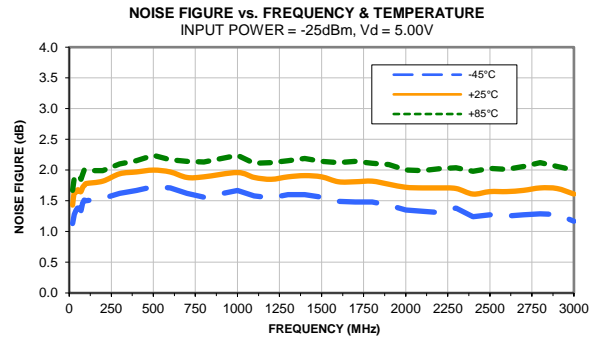

### Outline Dimensions

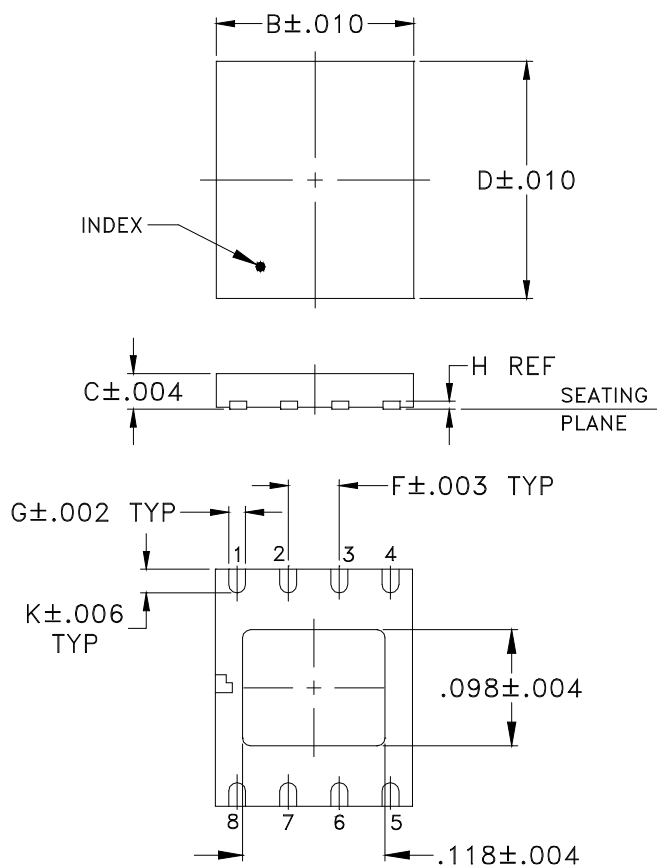

### PCB Land Pattern

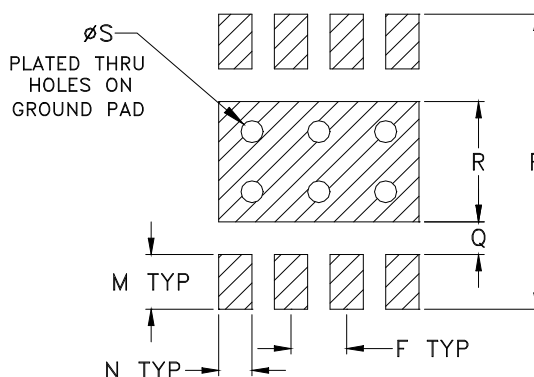

Suggested Layout,  
Tolerance to be within  $\pm .002$

CASE #	A	B	C	D	E	F	G	H	J	K	L	M	N
DL1020	--	.193 (4.90)	.035 (0.90)	.236 (6.00)	--	.050 (1.27)	.017 (0.42)	.008 (0.20)	--	.024 (0.60)	--	.050 (1.27)	.030 (0.76)

CASE #	P	Q	R	S	T	WT. GRAM
DL1020	.270 (6.86)	.030 (0.76)	.110 (2.79)	.020 (0.51)	--	.08

Dimensions are in inches (mm). Tolerances: 2 Pl.  $\pm .01$ ; 3Pl.  $\pm .004$

#### Notes:

- Case material: Plastic.
- Termination finish:  
For RoHS Case Styles: Tin-Silver alloy plate over Nickel barrier. All models, (+) suffix.  
For RoHS-5 Case Styles: Tin-Lead plate. All models, no (+) suffix.



P.O. Box 350166, Brooklyn, New York 11235-0003 (718) 934-4500 Fax (718) 332-4661 For detailed performance specs & shopping online see Mini-Circuits web site



The Design Engineers Search Engine Provides ACTUAL Data Instantly From MINI-CIRCUITS At: [www.minicircuits.com](http://www.minicircuits.com)

RF/IF MICROWAVE COMPONENTS

# Tape & Reel Packaging TR-F68

## DEVICE ORIENTATION IN T&R

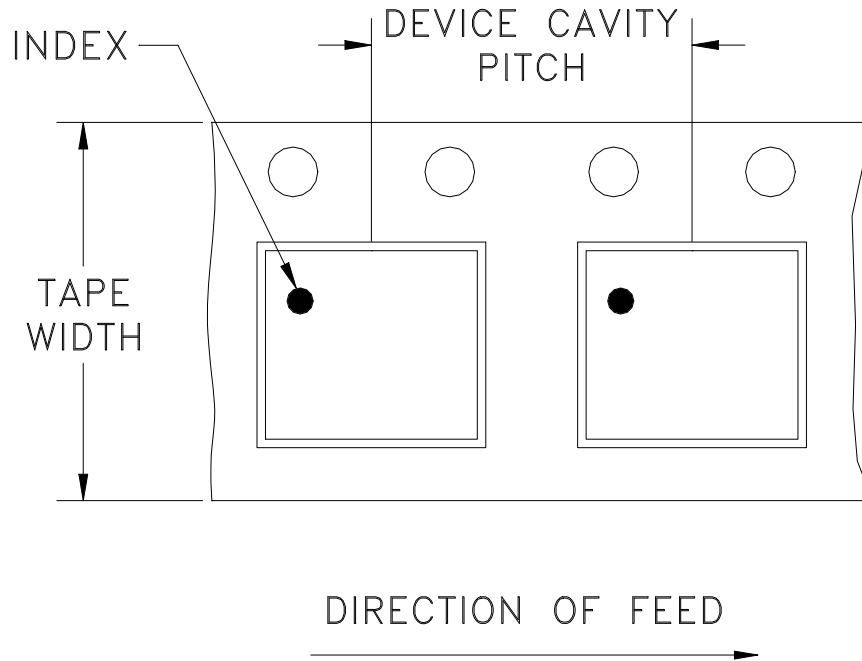

Tape Width, mm	Device Cavity Pitch, mm	Reel Size, inches	Devices per Reel see note	
12	8	7	Small quantity standard	20
				50
				100
				200
				500
		7	Standard	1000
		13	Standard	2000
				3000
4000				

Mini-Circuits carrier tape materials provide protection from ESD (Electro-Static Discharge) during handling and transportation. Tapes are static dissipative and comply with industry standards EIA-481/EIA-541.

Go to: [www.minicircuits.com/pages/pdfs/tape.pdf](http://www.minicircuits.com/pages/pdfs/tape.pdf)



INTERNET <http://www.minicircuits.com>

P.O. Box 350166, Brooklyn, New York 11235-0003 (718) 934-4500 Fax (718) 332-4661

Distribution Centers NORTH AMERICA 800-654-7949 • 417-335-5935 • Fax 417-335-5945 • EUROPE 44-1252-832600 • Fax 44-1252-837010

Mini-Circuits ISO 9001 & ISO 14001 Certified

THIRD ANGLE PROJECTION

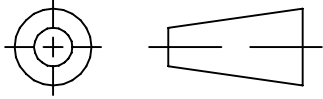

REVISIONS

REV	ECN No.	DESCRIPTION	DATE	DR	AUTH
OR	M125629	NEW RELEASE	04/20/10	MMG	RD

SUGGESTED MOUNTING CONFIGURATION FOR DL1020 CASE STYLE, "08AM04" PIN CODE

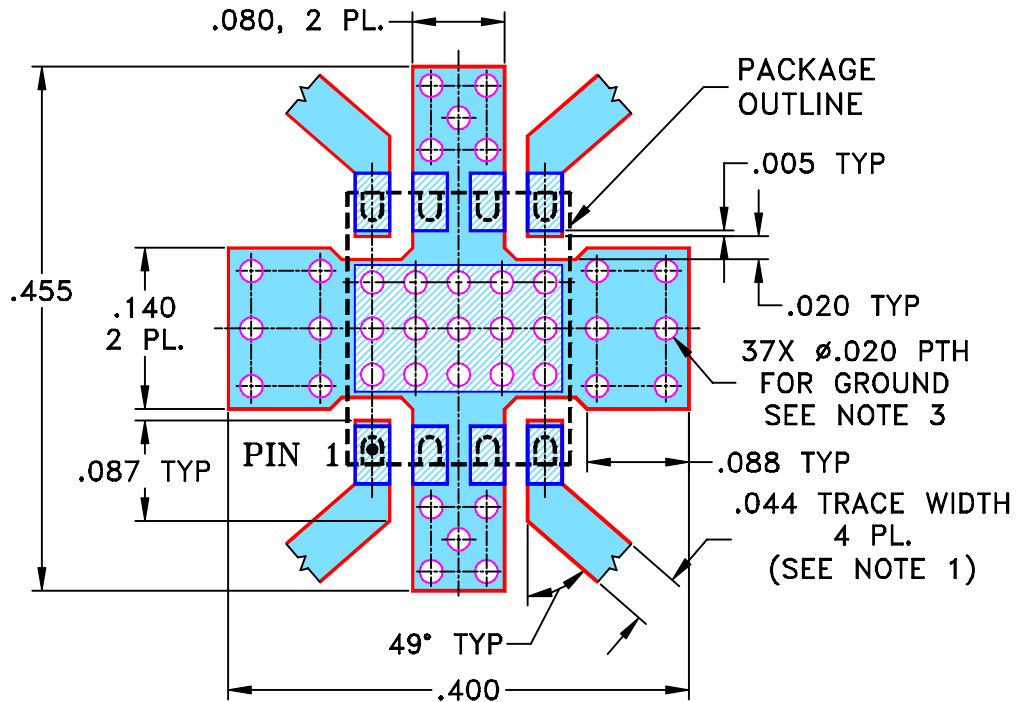

NOTES:

1. TRACE WIDTH IS SHOWN FOR ROGERS R04350B WITH DIELECTRIC THICKNESS .020" ± .0015". COPPER: 1/2 OZ. EACH SIDE. FOR OTHER MATERIALS TRACE WIDTH MAY NEED TO BE MODIFIED.
2. BOTTOM SIDE OF THE PCB IS CONTINUOUS GROUND PLANE.
3. RECOMMEND TO PLUG 15 PTH UNDER THE UNIT TO AVOID SOLDER WICKING.

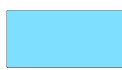

DENOTES PCB COPPER LAYOUT WITH SMOBC (SOLDER MASK OVER BARE COPPER)



DENOTES COPPER LAND PATTERN FREE OF SOLDER MASK

UNLESS OTHERWISE SPECIFIED	INITIALS	DATE
DIMENSIONS ARE IN INCHES TOLERANCES ON: 2 PL DECIMALS ± 3 PL DECIMALS ± .005 ANGLES ± FRACTIONS ±	DRAWN	MMG 01/26/10
	CHECKED	IL 04/20/10
	APPROVED	RD 04/20/10



**Mini-Circuits®** 13 Neptune Avenue  
Brooklyn NY 11235

PL, 08AM04, DL1020

Mini-Circuits®  
THIS DOCUMENT AND ITS CONTENTS ARE THE PROPERTY OF MINI-CIRCUITS. EXCEPT FOR USE EXPRESSLY GRANTED, IN WRITING, TO ITS VENDORS, VENDEE AND THE UNITED STATES GOVERNMENT, MINI-CIRCUITS RESERVES ALL PROPRIETARY DESIGN, USE, MANUFACTURING AND REPRODUCTION RIGHTS THERETO. THESE CONTENTS SHALL NOT BE USED, DUPLICATED OR DISCLOSED TO ANY OUTSIDE PARTY, IN WHOLE OR IN PART, WITHOUT WRITTEN PERMISSION OF MINI-CIRCUITS.

SIZE A	CODE IDENT 15542	DRAWING NO: 98-PL-322	REV: OR
FILE: 98PL322	SCALE: 6:1	SHEET: 1 OF 1	

# Evaluation Board and Circuit

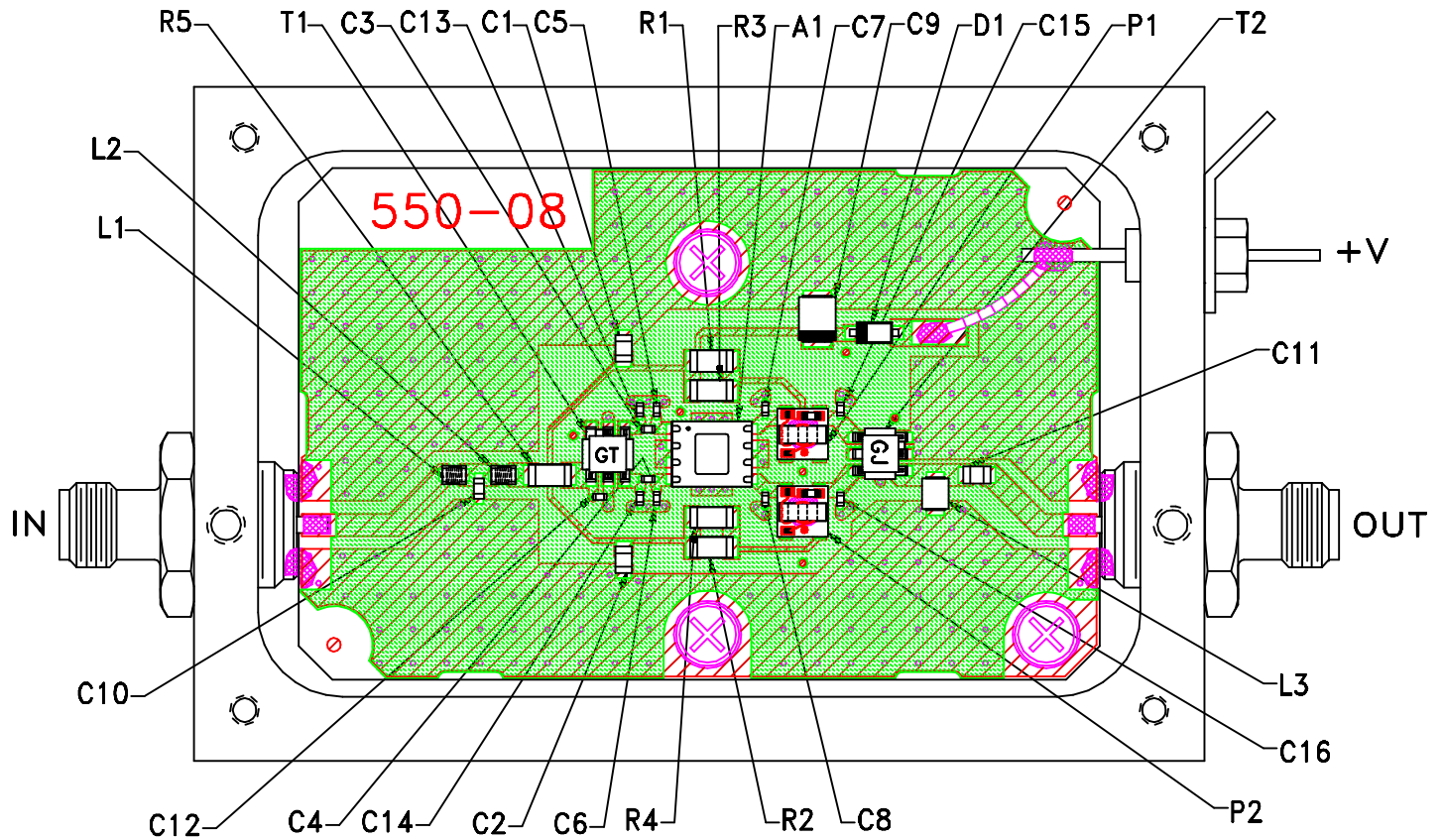

TB-666-50-105+

## NOTES:

1. SMA Female connectors.
2. PCB material: Rogers R04350 or equivalent,  
dielectric constant=3.5,  
dielectric thickness=.030 inch.

 **Mini-Circuits®**

# Evaluation Board and Circuit

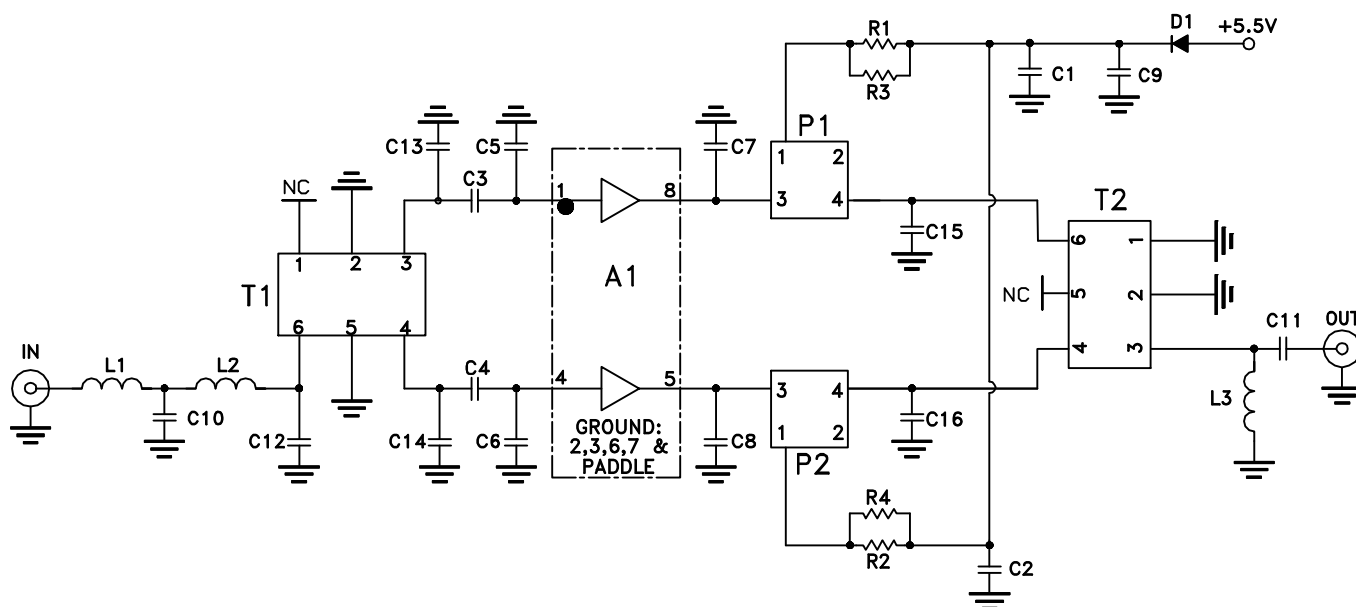

## Note:

Numbers inside the boxes indicate Pin Numbers.

COMPONENT	VALUE	SIZE
A1	Mini-Circuits MPGA-105+	PER DATA SHEET
C1,C2	.039 uF	0805
C3,C4	.001 uF	0402
C5,C6	.2 pF	0402
C7,C8	1.1 pF	0402
C9	1.0 uF	1311
C10	.4 pF	0603
C11	270 pF	0805
C12	.4 pF	0402
C13	.7 pF	0402
C14	.3 pF	0402
C15	.6 pF	0402
C16	1.0 pF	0402
D1	Diode, Schottky Rectifier Vf=.385V @ .5A, Vr=10V MAX	-
L1,L2	1.1 nH	.073"X.054"
L3	1.5 uH	1008
R1,R2	5.11 Ohm	1206
R3,R4	7.50 Ohm	1206
T1	Mini-Circuits TCM2-33WX+	PER DATA SHEET
T2	Mini-Circuits TCM2-43X+	PER DATA SHEET
P1,P2	Mini-Circuits TCBT-6G+	PER DATA SHEET

## Schematic Diagram

 Mini-Circuits®

All Mini-Circuits products are manufactured under exacting quality assurance and control standards, and are capable of meeting published specifications after being subjected to any or all of the following physical and environmental test.

Specification	Test/Inspection Condition	Reference/Spec
Operating Temperature	-45° to 85°C or -40° to 85°C Ambient Environment	Individual Model Data Sheet
Storage Temperature	-65° to 150° C Ambient Environment	Individual Model Data Sheet
Thermal Shock	-55° to 100°C, 100 cycles	MIL-STD-202, Method 107, Condition A-3, except +100°C
Mechanical Shock	1.5Kg, 0.5 ms, 5 shock pulses, Y1 direction only	MIL-STD-883, Method 2002, Condition B, except Y1 direction only
Vibration (Variable Frequency)	50g peak	MIL-STD-883, Method 2007, Condition B
Autoclave	15 psig, 100% RH, 121°C, 96 hours	JESD22-A102, Condition C
HAST	130°C, 85% RH, 96 hours	JESD22-A110
Solderability	10X Magnification	J-STD-002, Para 4.2.5, Test S, 95% Coverage
Solder Reflow Heat	Sn-Pb Eutetic Process: 240°C peak Pb-Free Process: 260°C peak	J-STD-020, Table 4-1, 4-2 and 5-2; Figure 5-1
Moisture Sensitivity: Level 1	Bake at 125°C for 24 hours Soak at 85°C/85% RH for 168 hours, Reflow 3 cycles at 260°C peak	J-STD-020
Marking Resistance to Solvents	Isopropyl alcohol + mineral spirits at 25°C; terpene defluxer at 25°C; distilled water + proylene glycol monomethyl ether +	MIL-STD-202, Method 215



All Mini-Circuits products are manufactured under exacting quality assurance and control standards, and are capable of meeting published specifications after being subjected to any or all of the following physical and environmental test.

Specification	Test/Inspection Condition	Reference/Spec
	monoethanolamine at 63°C to 70°C	