



HIGH DIRECTIVITY

Monolithic Amplifier Die

MNA-7A-D+

50Ω 1.5 to 6 GHz

THE BIG DEAL

- Choice of supply voltage, +2.8V to +5V
- Internal DC blocking at RF input and output
- High directivity, 18-38 dB typ.
- Output power, up to +17.4 dBm typ.

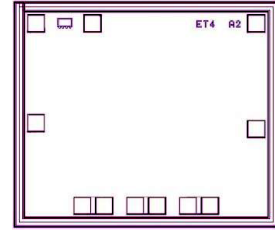

+RoHS Compliant

The +Suffix identifies RoHS Compliance. See our website for methodologies and qualifications

APPLICATIONS

- Buffer amplifier
- Cellular infrastructure
- Communications satellite
- Defense

SEE ORDERING INFORMATION ON THE LAST PAGE

PRODUCT OVERVIEW

MNA-7A-D+ is a wideband PHEMT based MMIC amplifier die with high active Directivity. MNA integrates the entire matching network and majority of the bias circuit inside the die, reducing the need for complicated external circuits. This approach makes the MNA amplifier die extremely straightforward to use. This design operates on a single 2.8 to 5V supply, is well matched for 50Ω. [MNA series models are available in Die and packaged form.](#)

KEY FEATURES

Features	Advantages
Excellent Active Directivity (Isolation- Gain) 18-38 dB	Ideal for use as a buffer amplifier minimizing interaction of adjacent circuits
Integrates DC blocks and RF choke	Minimizes external components, component count and circuit area.
Single +2.8 to +5V operation	Amplifier can be used at low voltage such as +3V or standard +5V. +5V operation results in higher P1dB and OIP3.
Unpackaged die	Enables the user to integrate the amplifier directly into hybrids.

REV. B
ECO-015286
MNA-7A-D+
MCL NY
221007





HIGH DIRECTIVITY

Monolithic Amplifier Die

MNA-7A-D+

50Ω 1.5 to 6 GHz

ELECTRICAL SPECIFICATIONS¹ AT 25°C

Parameter	Condition (GHz)	Vs=5V			Vs=2.8V	Units
		Min.	Typ.	Max.	Typ.	
Frequency Range		1.5		6.0	1.5-6.0	GHz
Gain	1.5		17.5		15.0	dB
	2.0		17.7		15.6	
	3.5		17.7		15.7	
	5.0		18.0		16.7	
	5.9		12.6		9.2	
	6.0		11.7		8.1	
Input Return Loss	1.5		7.5		7.5	dB
	2.0		11.0		10.5	
	3.5		17.4		15.9	
	5.0		15.5		15.5	
	5.9		11.2		10.1	
	6.0		11.1		10.2	
Output Return Loss	1.5		18.7		18.7	dB
	2.0		21.6		16.6	
	3.5		21.3		13.7	
	5.0		15.8		12.2	
	5.9		14.3		9.9	
	6.0		13.5		9.5	
Output Power at P1dB	1.5		17.4		12.4	dBm
	2.0		17.1		13.0	
	3.5		14.8		11.9	
	5.0		16.1		13.4	
	5.9		15.6		10.9	
	6.0		14.4		9.7	
Output IP3	1.5		28.8		23.7	dBm
	2.0		28.5		24.3	
	3.5		25.8		22.6	
	5.0		27.4		24.5	
	5.9		27.0		21.7	
	6.0		25.6		20.3	
Noise Figure (dB)	1.5		6.9		7.3	dB
	2.0		5.7		6.2	
	3.5		4.3		4.8	
	5.0		3.7		4.0	
	5.9		4.5		5.2	
	6.0		4.7		5.4	
Directivity (Isolation-Gain)	1.5		32.4		35.1	dB
	2.0		27.2		29.2	
	3.5		20.6		22.6	
	5.0		19.4		18.9	
	5.9		23.5		25.9	
	6.0		24.5		27.1	
DC Current			82	103	77	mA
Device Current Variation vs. Temperature ²			31		21	μA/°C
Device Current Variation vs Voltage			0.0009 ³		0.003 ⁴	mA/mV
Thermal resistance at 85°C (Junction to Lead)			60		60	°C/W

1. Measured on Mini-Circuits characterization test board. Die packaged in 3x3 mm MCLP package and soldered on test board TB-186-7A+

2. (Current at 85°C - Current at -45°C)/130

3. (Current at 5.25V - Current at 3.9V)/1.35

4. (Current at 3.9V - Current at 2.66V)/1.24





HIGH DIRECTIVITY

Monolithic Amplifier Die

MNA-7A-D+

50Ω 1.5 to 6 GHz

MAXIMUM RATINGS^{1,5}

Parameter	Ratings
Operating Temperature	-40°C to 85°C
DC Voltage	7V at DC1 (DC2 connected to DC1 via 6.81Ω) 1V at RF IN & RF OUT
Power Dissipation	750 mW
Input Power	+10 dBm (continuous operation) +26 dBm over 1.5 to 3.7 GHz (5 minutes max) +20 dBm over 3.7 to 6 GHz (5 minutes max)

5. Permanent damage may occur if any of these limits are exceeded. These ratings are not intended for continuous normal operation.

SIMPLIFIED SCHEMATIC AND PAD DESCRIPTION

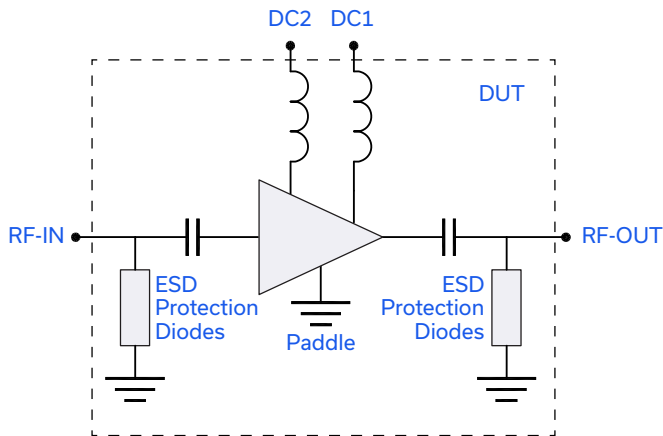

Function	Description
RF IN	RF input pad.
RF-OUT	RF output pad
DC1 & DC2	DC Supply pad. Connect DC2 to DC1 via 6.81Ω resistor

1. Bond Pad material - Gold
2. Bottom of Die - Gold plated



HIGH DIRECTIVITY

Monolithic Amplifier Die

MNA-7A-D+

50Ω 1.5 to 6 GHz

CHARACTERIZATION CIRCUIT

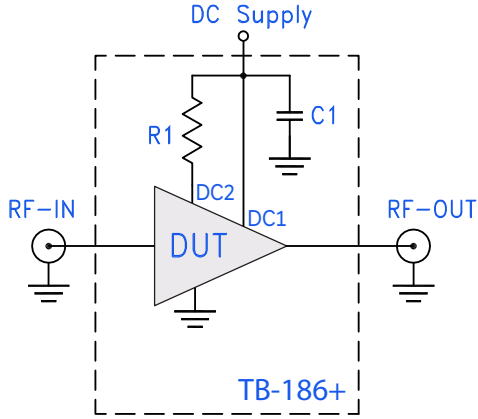

Fig 1. Block Diagram of Test Circuit used for characterization. (Die packaged in 3x3 mm MCLP package and soldered on Mini-Circuits Characterization test board TB-186+) Gain, Return loss, Output power at 1dB compression (P1 dB) , output IP3 (OIP3) and noise figure measured using Agilent's N5242A PNA-X microwave network analyzer.

Conditions:

1. Gain and Return loss: Pin= -25dBm
2. Output IP3 (OIP3): Two tones, spaced 1 MHz apart, 0 dBm/tone at output.

Component	Value	Units
R1	6.81	Ω
C1	1000	pF

RECOMMENDED APPLICATION CIRCUIT

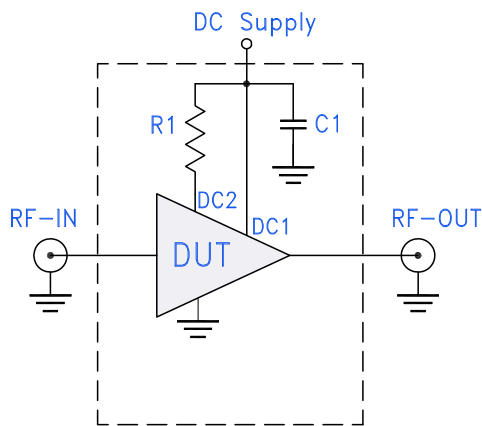

Fig 2. Test Board includes case, connectors, and components soldered to PCB

Component	Value	Units
R1	6.81	Ω
C1	1000	pF



HIGH DIRECTIVITY

Monolithic Amplifier Die

MNA-7A-D+

50Ω 1.5 to 6 GHz

DIE LAYOUT

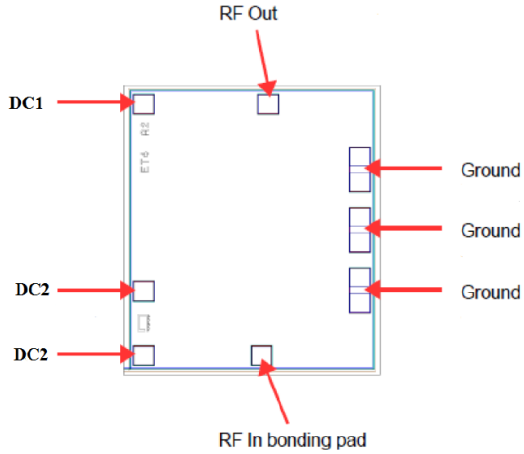

Fig 3. Die Layout

BONDING PAD POSITION

(Dimensions in μm , Typical)

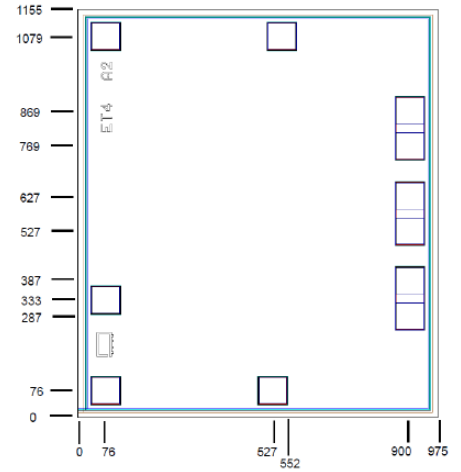

Fig 4. Bonding Pad Positions

CRITICAL DIMENSIONS

Parameter	Values
Die Thickness, μm	100
Die Width, μm	975
Die Length, μm	1155
Bond Pad Size (RF In, RF Out, DC), μm	80 x 80
Bond Pad Size (Ground pad), μm	80 x 180



HIGH DIRECTIVITY

Monolithic Amplifier Die

MNA-7A-D+

50Ω 1.5 to 6 GHz

ASSEMBLY DIAGRAM

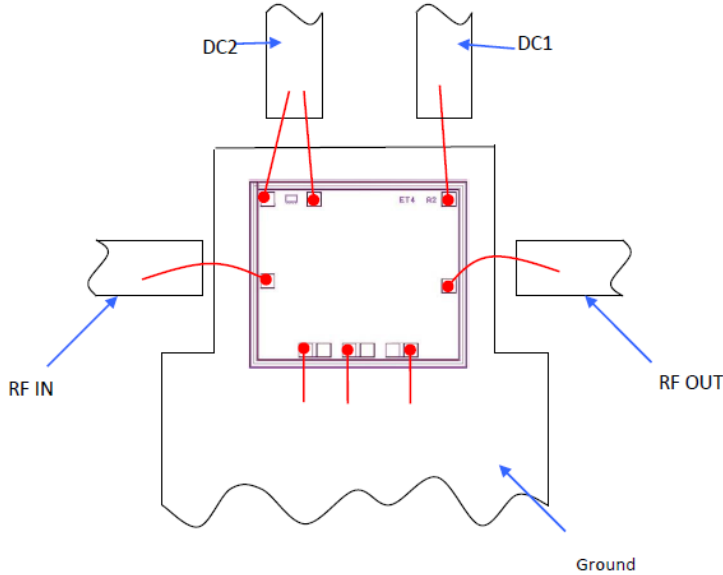

Note: Ground bond wires are optional.

RECOMMENDED WIRE LENGTH, TYPICAL

Wire	Wire Length (mm)	Wire Loop Height (mm)
RF In, RF Out, DC	0.75	0.15
Ground	0.40	0.15



HIGH DIRECTIVITY

Monolithic Amplifier Die

MNA-7A-D+

50Ω 1.5 to 6 GHz

ADDITIONAL DETAILED TECHNICAL INFORMATION IS AVAILABLE ON OUR DASH BOARD.

Performance Data	Data Table Swept Graphs S-Parameter (S2P Files) Data Set with and without port extension(.zip file)
Case Style	Die
Die Ordering and packaging information	Quantity, Package Small, Gel - Pak: 5,10,50,100 KGD* Medium†, Partial wafer: KGD*<1395 Large†, Full Wafer Model No. MNA-7A-DG+ MNA-7A-DP+ MNA-7A-DF+ †Available upon request contact sales representative Refer to AN-60-067
Environmental Ratings	ENV-80

*Known Good Die ('KGD') means that the die in question have been subjected to Mini-Circuits DC test performance criteria and measurement instructions and that the parametric data of such die fall within a predefined range. While DC testing is not definitive, it does provide a higher degree of confidence that die are capable of meeting typical RF electrical performance specified by Mini-Circuits.

ESD RATING**

Human Body Model (HBM): Class 1A (250 to < 500V) in accordance with ANSI/ESD STM 5.1 - 2001

**Tested in _x_ xxL MCLP Package

NOTES

- A. Performance and quality attributes and conditions not expressly stated in this specification document are intended to be excluded and do not form a part of this specification document.
- B. Electrical specifications and performance data contained in this specification document are based on Mini-Circuit's applicable established test performance criteria and measurement instructions.
- C. The parts covered by this specification document are subject to Mini-Circuits standard limited warranty and terms and conditions (collectively, "Standard Terms"); Purchasers of this part are entitled to the rights and benefits contained there in. For a full statement of the standard. Terms and the exclusive rights and remedies thereunder, please visit Mini-Circuits' website at www.minicircuits.com/terms/viewterm.html
- D. Mini-Circuits does not warrant the accuracy or completeness of the information, text, graphics and other items contained within this document and same are provided as an accommodation and on an As is basis, with all faults.
- E. Purchasers of this part are solely responsible for proper storing, handling, assembly and processing of Known Good Dice (including, without limitation, proper ESD preventative measures, die preparation, die attach, wire bonding and related assembly and test activities), and Mini-Circuits assumes no responsibility therefor or for environmental effects on Known Good Dice.
- F. Mini-Circuits and the Mini-Circuits logo are registered trademarks of Scientific Components Corporation d/b/a Mini-Circuits. All other third-party trademarks are the property of their respective owners. A reference to any third-party trademark does not constitute or imply any endorsement, affiliation, sponsorship, or recommendation by any such third-party of Mini-Circuits or its products.



Typical Performance Data

NOTE: Use PDF Bookmarks to view DATA at required conditions

Definitions:

Input Return Loss = -S11 (dB)

Gain(Power Gain) = S21 (dB)

Reverse Isolation = -S12 (dB)

Output Return Loss = -S22 (dB)

TEST CONDITIONS: Vd = 5.00V, Id = 77.15mA @ Temperature = +25°C

FREQ	Gain	Isolation	Input Return Loss	Output Return Loss	Stability		IP-3 Output	1dB Comp. Output	Noise Figure
					K	Measure			
(MHz)	(dB)	(dB)	(dB)	(dB)	K	Measure	(dBm)	(dBm)	(dB)
1000	15.33	73.97	3.95	19.34	252.13	1.39	25.44	13.59	8.56
1100	16.33	73.62	4.57	22.35	236.87	1.34	27.22	15.36	8.03
1200	17.06	62.37	5.29	26.47	64.71	1.29	28.38	16.41	7.53
1300	17.59	57.23	6.04	31.74	36.01	1.25	29.00	16.89	7.09
1400	17.94	54.27	6.80	37.33	25.91	1.21	28.90	17.13	6.80
1500	18.18	52.16	7.56	38.24	20.63	1.17	28.78	17.04	6.47
1600	18.29	50.24	8.35	35.58	16.91	1.14	28.67	16.84	6.23
1700	18.35	49.01	9.11	33.11	14.98	1.12	28.59	16.98	6.03
1800	18.35	47.83	9.90	31.99	13.38	1.10	28.76	16.89	5.79
1900	18.33	46.68	10.65	30.87	11.97	1.08	28.71	16.94	5.64
2000	18.29	46.02	11.30	29.71	11.28	1.07	28.31	16.81	5.45
2100	18.25	45.36	12.01	29.22	10.64	1.06	28.03	16.46	5.31
2200	18.18	44.77	12.73	28.56	10.11	1.05	27.65	16.30	5.13
2300	18.14	44.14	13.44	27.41	9.53	1.04	27.60	16.37	5.04
2400	18.16	43.73	14.15	26.67	9.13	1.03	27.35	16.24	4.86
2500	18.10	43.42	14.84	25.98	8.92	1.03	27.12	16.02	4.79
2600	18.12	43.03	15.62	25.16	8.56	1.02	26.91	15.78	4.77
2700	18.13	42.96	16.55	24.70	8.51	1.02	26.70	15.58	4.69
2800	18.17	42.39	17.18	24.13	7.97	1.01	26.42	15.28	4.68
2900	18.22	41.66	17.76	23.54	7.30	1.01	26.24	15.11	4.64
3000	18.28	41.22	18.40	23.21	6.91	1.01	25.81	14.77	4.46
3100	18.32	40.98	18.96	23.34	6.70	1.00	25.68	14.67	4.39
3300	18.46	40.55	19.88	23.49	6.30	1.00	25.18	14.34	4.33
3500	18.61	39.89	20.03	22.61	5.74	1.00	25.18	14.26	4.14
3700	18.89	39.42	19.45	22.55	5.27	1.00	24.95	13.97	4.04
3900	19.22	39.09	18.81	22.12	4.88	1.00	24.75	13.77	3.94
4100	19.52	39.81	18.68	20.45	5.09	1.00	24.50	13.58	3.81
4300	19.87	39.35	18.96	20.66	4.65	0.99	24.45	13.68	3.72
4500	19.70	40.63	19.69	19.17	5.48	0.99	25.20	14.26	3.74
4700	19.51	40.08	18.35	19.80	5.24	1.00	25.82	14.57	3.65
4900	19.19	39.32	17.01	21.70	4.98	1.01	27.09	15.90	3.62
5100	18.59	38.56	15.64	25.81	4.87	1.02	28.45	16.29	3.73
5300	18.05	38.91	13.91	28.82	5.34	1.03	28.75	16.97	3.72
5500	17.17	38.00	13.30	22.91	5.28	1.03	28.97	17.39	3.84
5700	15.72	38.19	12.54	18.59	6.25	1.03	28.12	16.86	4.05
5900	13.96	38.04	12.32	14.98	7.36	1.02	26.46	15.17	4.32
6100	12.12	36.39	11.86	13.47	7.38	1.01	24.23	12.69	4.75
6300	9.95	37.69	12.17	12.02	10.81	0.99	21.21	9.83	5.36
6500	7.64	38.00	12.70	10.93	14.39	0.96	17.47	7.03	6.04



Typical Performance Data

Definitions:

Input Return Loss = -S11 (dB)

Gain(Power Gain) = S21 (dB)

Reverse Isolation = -S12 (dB)

Output Return Loss = -S22 (dB)

TEST CONDITIONS: Vd = 3.90V, Id = 76.12mA @ Temperature = +25°C

FREQ	Gain	Isolation	Input Return Loss	Output Return Loss	Stability		IP-3 Output	1dB Comp. Output	Noise Figure
					K	Measure			
(MHz)	(dB)	(dB)	(dB)	(dB)	K	Measure	(dBm)	(dBm)	(dB)
1000	14.51	75.72	4.02	18.90	342.73	1.38	24.45	12.68	8.63
1100	15.44	68.86	4.64	21.67	152.95	1.33	25.99	14.35	8.13
1200	16.14	60.42	5.35	25.35	57.83	1.29	27.11	15.43	7.67
1300	16.65	56.23	6.07	29.42	35.83	1.25	27.57	15.94	7.22
1400	17.02	53.61	6.80	32.00	26.73	1.21	27.61	16.17	6.93
1500	17.28	51.62	7.53	31.18	21.48	1.17	27.50	16.17	6.60
1600	17.42	49.79	8.28	29.01	17.68	1.15	27.53	16.08	6.40
1700	17.52	48.57	9.00	27.03	15.59	1.12	27.38	16.13	6.20
1800	17.55	47.37	9.74	25.82	13.85	1.10	27.64	16.09	5.96
1900	17.56	46.22	10.44	24.78	12.32	1.08	27.62	16.14	5.79
2000	17.55	45.53	11.04	23.87	11.53	1.07	27.34	15.98	5.64
2100	17.53	44.86	11.70	23.43	10.82	1.06	27.13	15.80	5.44
2200	17.48	44.23	12.37	23.11	10.22	1.05	26.74	15.68	5.34
2300	17.45	43.57	13.00	22.61	9.58	1.04	26.60	15.57	5.20
2400	17.48	43.13	13.63	22.33	9.14	1.03	26.29	15.42	5.04
2500	17.43	42.80	14.24	22.09	8.90	1.03	26.21	15.32	4.96
2600	17.44	42.38	14.93	21.78	8.52	1.02	25.91	14.97	4.93
2700	17.45	42.25	15.72	21.78	8.42	1.02	25.78	14.88	4.86
2800	17.48	41.69	16.24	21.42	7.89	1.01	25.62	14.58	4.85
2900	17.52	40.96	16.71	20.98	7.24	1.01	25.36	14.48	4.82
3000	17.57	40.55	17.23	20.79	6.88	1.01	25.11	14.20	4.61
3100	17.59	40.34	17.72	20.86	6.72	1.00	24.94	14.09	4.52
3300	17.69	39.98	18.55	21.09	6.39	1.00	24.56	13.79	4.47
3500	17.81	39.34	18.74	20.09	5.86	1.00	24.33	13.72	4.29
3700	18.07	38.97	18.47	19.44	5.44	1.00	24.17	13.39	4.19
3900	18.40	38.68	18.15	18.32	5.05	0.99	23.97	13.15	4.09
4100	18.71	39.39	18.29	16.49	5.25	0.99	23.92	13.03	3.98
4300	19.09	38.84	18.79	16.21	4.72	0.98	23.82	13.12	3.81
4500	19.02	39.43	19.75	15.55	5.07	0.98	24.41	13.63	3.84
4700	18.95	39.07	18.63	15.89	4.90	0.98	24.90	14.08	3.72
4900	18.59	38.36	17.07	17.35	4.72	0.99	26.02	14.82	3.77
5100	18.24	37.63	15.36	21.19	4.53	1.01	27.23	16.00	3.75
5300	17.42	37.35	13.58	28.35	4.78	1.03	28.06	16.31	3.80
5500	16.35	37.06	12.63	25.25	5.17	1.04	27.49	16.43	3.94
5700	14.62	37.46	11.95	18.42	6.46	1.04	26.62	15.78	4.14
5900	12.57	37.10	11.78	14.95	7.69	1.02	24.77	13.77	4.54
6100	10.56	35.81	11.41	13.21	8.17	1.01	22.31	11.29	5.02
6300	8.35	36.17	11.76	12.13	10.86	0.99	19.11	8.51	5.64
6500	6.03	36.80	12.24	11.07	15.05	0.97	15.12	5.59	6.48

Typical Performance Data

Definitions:

Input Return Loss = -S11 (dB)

Gain(Power Gain) = S21 (dB)

Reverse Isolation = -S12 (dB)

Output Return Loss = -S22 (dB)

TEST CONDITIONS: Vd = 5.25V, Id = 77.36mA @ Temperature = +25°C

FREQ	Gain	Isolation	Input Return Loss	Output Return Loss	Stability		IP-3 Output	1dB Comp. Output	Noise Figure
					K	Measure			
(MHz)	(dB)	(dB)	(dB)	(dB)	K	Measure	(dBm)	(dBm)	(dB)
1000	15.44	73.48	3.93	19.45	234.99	1.39	25.55	13.74	8.54
1100	16.44	74.11	4.55	22.51	246.75	1.34	27.37	15.51	8.00
1200	17.19	62.81	5.27	26.68	67.01	1.29	28.50	16.54	7.54
1300	17.71	57.37	6.02	31.99	36.02	1.25	29.10	17.03	7.07
1400	18.06	54.35	6.79	37.74	25.77	1.21	29.16	17.25	6.79
1500	18.29	52.22	7.56	39.12	20.51	1.17	28.90	17.15	6.44
1600	18.39	50.30	8.35	36.88	16.83	1.15	28.75	16.94	6.19
1700	18.45	49.08	9.12	34.58	14.93	1.12	28.72	17.07	6.00
1800	18.44	47.90	9.91	33.65	13.36	1.10	28.94	16.99	5.78
1900	18.41	46.75	10.66	32.53	11.96	1.08	28.78	17.04	5.62
2000	18.37	46.09	11.31	31.21	11.28	1.07	28.50	16.91	5.48
2100	18.32	45.45	12.03	30.58	10.66	1.06	28.15	16.56	5.28
2200	18.25	44.85	12.76	29.64	10.13	1.05	27.70	16.36	5.15
2300	18.20	44.22	13.47	28.15	9.55	1.04	27.69	16.49	5.00
2400	18.22	43.83	14.19	27.17	9.17	1.03	27.53	16.33	4.87
2500	18.16	43.53	14.89	26.30	8.98	1.03	27.22	16.10	4.78
2600	18.17	43.16	15.69	25.32	8.63	1.02	26.96	15.86	4.74
2700	18.19	43.08	16.63	24.67	8.58	1.02	26.77	15.64	4.68
2800	18.22	42.52	17.28	24.06	8.04	1.01	26.49	15.37	4.65
2900	18.28	41.77	17.87	23.47	7.34	1.01	26.32	15.18	4.63
3000	18.34	41.35	18.52	23.11	6.96	1.01	25.87	14.85	4.44
3100	18.38	41.13	19.12	23.19	6.77	1.00	25.72	14.73	4.35
3300	18.52	40.71	20.07	23.12	6.37	1.00	25.27	14.43	4.29
3500	18.68	40.04	20.22	22.34	5.79	1.00	25.27	14.37	4.11
3700	18.97	39.58	19.65	22.29	5.31	1.00	25.05	14.06	4.05
3900	19.31	39.21	18.98	22.19	4.89	1.00	24.76	13.85	3.96
4100	19.61	40.11	18.94	20.73	5.22	1.00	24.59	13.64	3.83
4300	19.95	39.58	19.21	21.42	4.74	1.00	24.52	13.70	3.77
4500	19.76	40.48	19.99	20.18	5.36	0.99	25.22	14.31	3.73
4700	19.57	40.31	18.52	20.68	5.36	1.00	25.88	14.68	3.70
4900	19.10	39.64	17.00	22.12	5.22	1.01	26.94	15.99	3.71
5100	18.73	38.93	15.59	26.83	5.01	1.02	28.32	16.40	3.57
5300	18.03	38.76	14.06	27.76	5.26	1.03	28.61	17.00	3.71
5500	17.24	38.29	13.32	22.26	5.40	1.03	29.17	17.52	3.89
5700	15.85	38.74	12.63	17.90	6.55	1.03	28.45	16.98	4.00
5900	14.10	38.03	12.46	14.77	7.24	1.01	26.79	15.41	4.28
6100	12.31	36.55	11.94	13.25	7.35	1.00	24.60	12.96	4.73
6300	10.19	37.25	12.26	11.90	9.98	0.98	21.46	10.08	5.26
6500	7.86	38.26	12.83	10.71	14.42	0.96	17.82	7.24	6.02



Typical Performance Curves

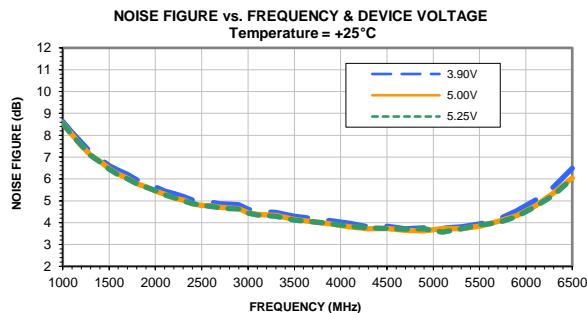
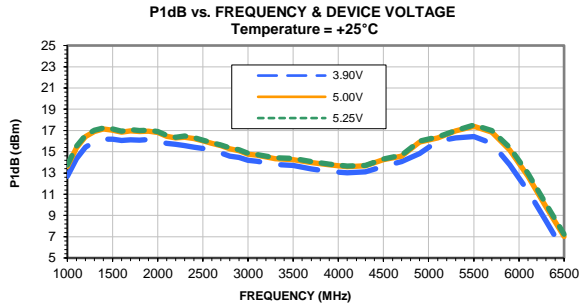
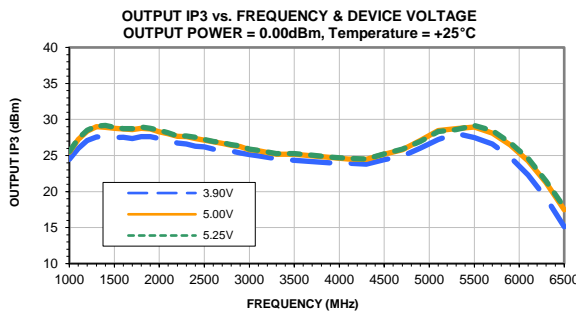
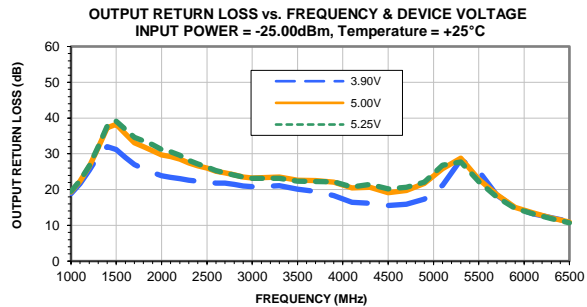
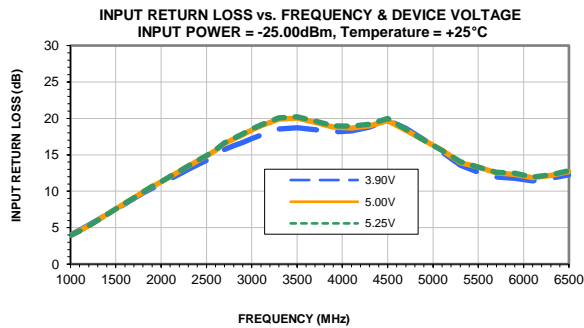
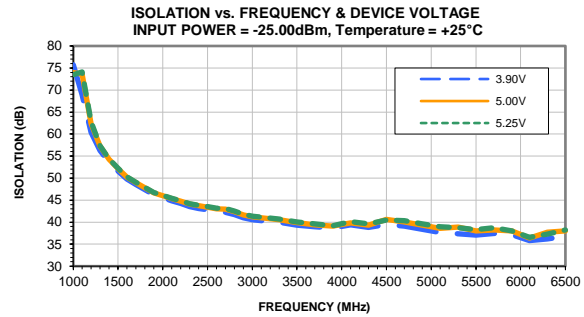
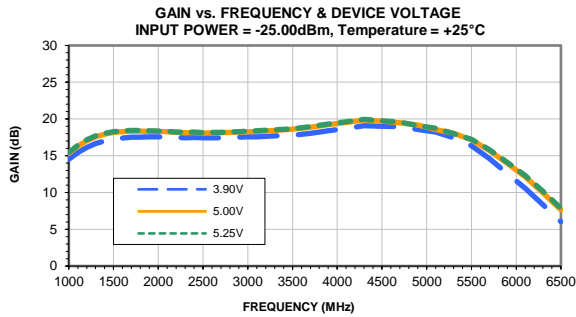

All Mini-Circuits products are manufactured under exacting quality assurance and control standards, and are capable of meeting published specifications after being subjected to any or all of the following physical and environmental test.

Specification	Test/Inspection Condition	Reference/Spec
Operating Temperature	-40° to 85° C or -40° to 105° C or -55° to 105° C or -45° to 105° C Ambient Environment	Refer to Individual Model Data Sheet
Storage Environment (Die)	-65° to 150°C	Individual Model Data Sheet
Storage Environment(Packaging)	-40° to 70°C and 40 to 60% humidity (In Factory Shipped Package)	