

## MMIC Surface Mount

# Wideband Double Balanced Mixer Die

# MDB-73H-D+

Level 15 (LO Power 15dBm) 2200-7000 MHz

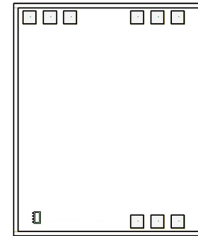

## The Big Deal

- Wide bandwidth, 2.2 to 7 GHz
- High L-I Isolation, 46 dB typ
- Useable as Up & Down Converter

## Product Overview

MDB-73H-D+ is an advanced wideband frequency mixer die fabricated using InGap HBT technology with integrated LO and RF Baluns. It has repeatable performance making it suitable for volume production.

## Key Features

Feature	Advantages
Double Balanced	Results in excellent LO-RF (33-40 dB typical) & LO-IF (32-52 dB typical) Isolations minimizing need for external filtering
Wide Bandwidth, 2.2 to 7 GHz	Useful in wideband systems or in several narrowband systems. Reducing inventory
Wide IF Bandwidth DC-1600 MHz	Usable in first (high IF~860 MHz) and second down (low IF~70 MHz) converter applications. IF as low as DC enables use in phase detector applications.
Low Thermal Resistance T <sub>j</sub> =88°C typical at 85°C ground lead temperature & LO=+15 dBm	Extremely High Reliability improving overall system reliability
Unpackaged die	Enables user to integrate it directly into hybrids.



# MMIC Surface Mount Wideband Double Balanced Mixer Die **MDB-73H-D+**

Level 15 (LO Power 15dBm) 2200-7000 MHz

## Product Features

- Wide bandwidth 2200 to 7000 MHz
- High L-I Isolation, 46 dB typ. at 4 GHz
- Usable as Up & Down Converter

## Typical Applications

- Satellite up and down converters
- Defense radar & communication
- VSAT

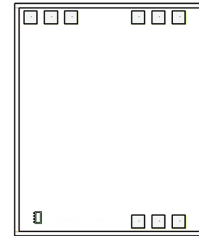

**+RoHS Compliant**

The +Suffix identifies RoHS Compliance. See our web site for RoHS Compliance methodologies and qualifications

Ordering Information: Refer to Last Page

## General Description

MDB-73H-D+ is an advanced wideband frequency mixer die fabricated using InGaP HBT technology and offers flat conversion loss over a broad frequency range and with high IP3. In addition, the MDB-73H-D+ has good input and output return loss over a broad frequency range without the need for external matching components. It has repeatable performance from lot to lot and has very good thermal performance.

## Simplified Schematic and Pad description

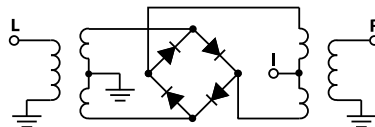

Pad	Description (See Fig. 1)
RF-IN	RF input pad
LO-IN	LO input pad
IF-OUT	IF input pad
GND	Connect to Ground

Note: 1. Bond Pad material - Gold  
2. Bottom of Die - Gold plated

**Electrical Specifications<sup>1</sup> at 25°C, unless noted**

Parameter	Condition (GHz)	Min.	Typ.	Max.	Units
RF Frequency Range		2.2		7.0	GHz
LO Frequency Range		2.2		7.0	GHz
IF Frequency Range		DC		1.6	GHz
LO Power			+15		dBm
Conversion Loss (at IF=30 MHz)	2.2		10.2		dB
	3.0		7.2		
	4.0		7.3		
	5.0		8.5		
	6.0		9.2		
	7.0		9.0		
LO-RF Isolation	2.2		38.6		dB
	3.0		36.4		
	4.0		35.6		
	5.0		40.0		
	6.0		35.3		
	7.0		33.4		
LO-IF Isolation	2.2		32.3		dB
	3.0		40.7		
	4.0		46.6		
	5.0		51.6		
	6.0		47.1		
	7.0		41.1		
RF-IF Isolation	2.2		9.6		dB
	3.0		12.1		
	4.0		15.1		
	5.0		16.0		
	6.0		13.7		
	7.0		12.7		
Input at 1dB Compression	2-2 - 7.0		10		dBm
Input IP3	2.2		15.7		dBm
	3.0		16.0		
	4.0		16.6		
	5.0		18.2		
	6.0		24.2		
	7.0		21.6		
Noise Figure <sup>2</sup>	2.2		8.9		dB
	4.0		9.0		
Thermal Resistance <sup>2</sup> (junction-to-ground lead)			105		°C/W

1. Measured on Mini-Circuits die Characterization test board . See Characterization Test Circuit Figure 1

**Absolute Maximum Ratings<sup>2,3</sup>**

Parameter	Ratings
Operating Temperature	-40°C to 85°C
RF Power	21 dBm
LO Power	21 dBm
IF Current	30 mA

2. Die performance measured in industry standard 4x4mm, 24-lead MCLP package.

3. Permanent damage may occur if any of these limits are exceeded.

Electrical maximum ratings are not intended for continuous normal operation.

**Characterization Test Circuit**

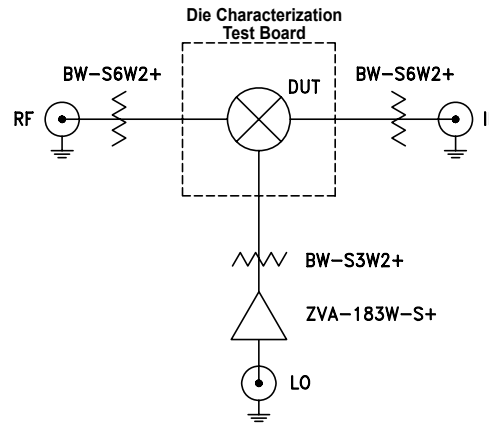

Figure 1A. Block Diagram of Test Circuit used for die characterization of Conversion Loss, Isolations (LO-RF, LO-IF, RF-IF) and Return Loss (LO, RF, IF)

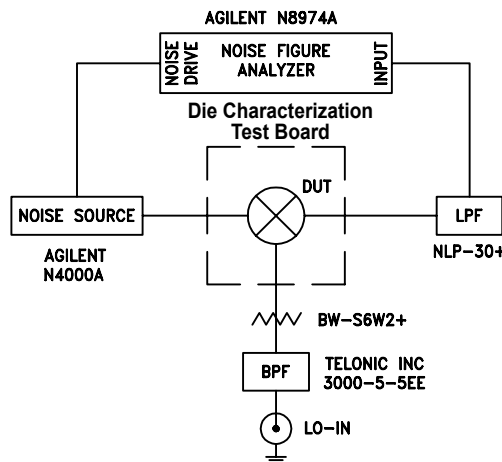

Figure 1B. Block Diagram of Test Circuit used for die characterization of Noise Figure

Figure 1. Block Diagram of Test Circuit used for characterization. conversion loss, Isolation and input IP3 are measured using Agilent N5242A PNA-X Microwave network analyzers and E8257D PSG signal generators.

Conditions (Down Converter):

1. Conversion Loss, Isolations (L-R, L-I & R-I): RF= 0 dBm, LO=+15 dBm, IF=30 MHz
2. Output IP3 (OIP3): Two tones, spaced 1 MHz apart, 0 dBm/tone at output.
3. Noise Figure: LO=+15 dBm

**Die Layout**

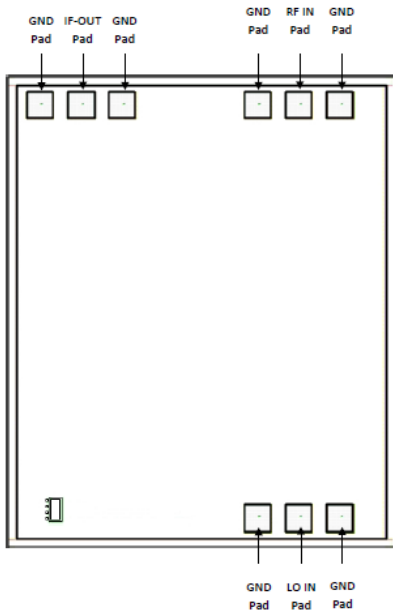

Fig 2. Die Layout

**Bonding Pad Position**  
(Dimensions in  $\mu\text{m}$ , Typical)

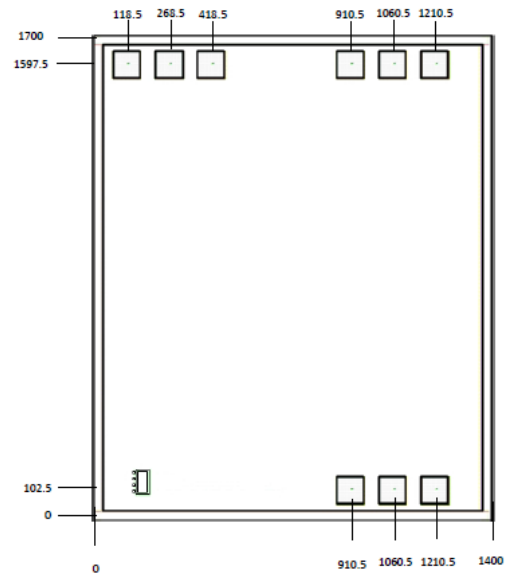

Fig 3. Bonding Pad Positions

**Critical Dimensions**

Parameter	Values
Die Thickness, $\mu\text{m}$	100
Die Width, $\mu\text{m}$	1400
Die Length, $\mu\text{m}$	1700
Bond Pad Size, $\mu\text{m}$	100 x 100

### Assembly and Handling Procedure

1. Storage  
Dice should be stored in a dry nitrogen purged desiccators or equivalent.
2. ESD  
MMIC Gallium Arsenide (GaAs) amplifier dice are susceptible to electrostatic and mechanical damage. Die are supplied in antistatic protected material, which should be opened in clean room conditions at an appropriately grounded anti-static workstation. Devices need careful handling using correctly designed collets, vacuum pickup tips or sharp antistatic tweezers to deter ESD damage to dice.
3. Die Attach  
The die mounting surface must be clean and flat. Using conductive silver filled epoxy, recommended epoxies are DieMat DM6030Hk-PT/H579/H579 or Ablestik 84-1LMISR4. Apply sufficient epoxy to meet required epoxy bond line thickness, epoxy fillet height and epoxy coverage around total die periphery. Parts shall be cured in a nitrogen filled atmosphere per manufacturer's cure condition. It is recommended to use antistatic die pick up tools only.
4. Wire Bonding  
Bond pad openings in the surface passivation above the bond pads are provided to allow wire bonding to the dice gold bond pads. Thermosonic bonding is used with minimized ultrasonic content. Bond force, time, ultrasonic power and temperature are all critical parameters. Suggested wire is pure gold, 1 mil diameter. Bonds must be made from the bond pads on the die to the package or substrate. All bond wires should be kept as short as low as reasonable to minimize performance degradation due to undesirable series inductance.

### Assembly Diagram

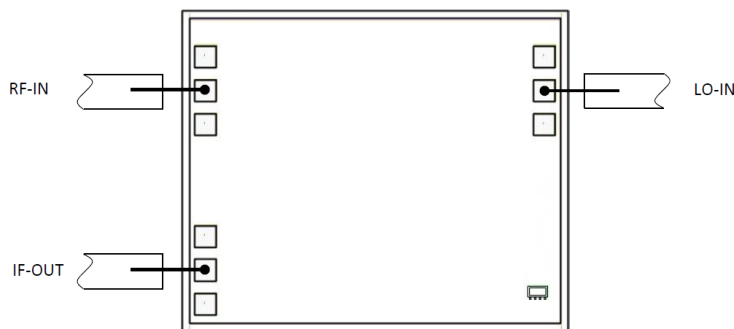

### Recommended Wire Length, Typical

Wire	Wire Length (mm)	Wire Loop Height (mm)
RF-IN, RF-OUT, and DC-IN	1.0	0.15

### RF Reference Plane - No port extension

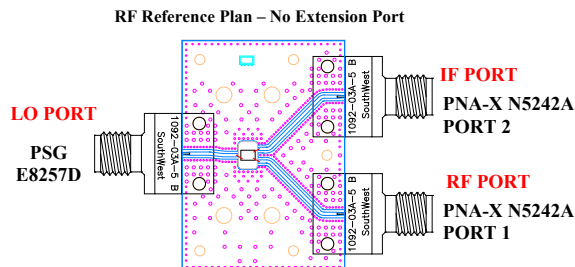

<b>Additional Detailed Technical Information</b> <i>additional information is available on our dash board.</i>	
<b>Performance Data</b>	Data Table
	Swept Graphs
<b>Case Style</b>	Die
<b>Die Ordering and packaging information</b>	Quantity, Package                      Model No. Small, Gel - Pak: 10,50,100 KGD*      MDB-73H-DG+ Medium†, Partial wafer: KGD* < 835      MDB-73H-DP+ Large†, Full Wafer                      MDB-73H-DF+
	†Available upon request contact sales representative  Refer to <a href="#">AN-60-067</a>
<b>Environmental Ratings</b>	ENV-80

\*Known Good Dice ("KGD") means that the dice in question have been subjected to Mini-Circuits DC test performance criteria and measurement instructions and that the parametric data of such dice fall within a predefined range. While DC testing is not definitive, it does help to provide a higher degree of confidence that dice are capable of meeting typical RF electrical parameters specified by Mini-Circuits.

**ESD Rating\*\***

Human Body Model (HBM): Class 1B (500 to 1000V) in accordance with ANSI/ESD STM 5.1 - 2001

\*\* Tested in industry standard 24-lead, 4x4mm MCLP package.

**Additional Notes**

- A. Performance and quality attributes and conditions not expressly stated in this specification document are intended to be excluded and do not form a part of this specification document.
- B. Electrical specifications and performance data contained in this specification document are based on Mini-Circuit's applicable established test performance criteria and measurement instructions.
- C. The parts covered by this specification document are subject to Mini-Circuits standard limited warranty and terms and conditions (collectively, "Standard Terms"); Purchasers of this part are entitled to the rights and benefits contained therein. For a full statement of the Standard Terms and the exclusive rights and remedies thereunder, please visit Mini-Circuits' website at [www.minicircuits.com/MCLStore/terms.jsp](http://www.minicircuits.com/MCLStore/terms.jsp)
- D. Mini-Circuits does not warrant the accuracy or completeness of the information, text, graphics and other items contained within this document and same are provided as an accommodation and on an "As is" basis, with all faults.
- E. Purchasers of this part are solely responsible for proper storing, handling, assembly and processing of Known Good Dice (including, without limitation, proper ESD preventative measures, die preparation, die attach, wire bonding and related assembly and test activities), and Mini-Circuits assumes no responsibility therefor or for environmental effects on Known Good Dice.
- F. Mini-Circuits and the Mini-Circuits logo are registered trademarks of Scientific Components Corporation d/b/a Mini-Circuits. All other third-party trademarks are the property of their respective owners. A reference to any third-party trademark does not constitute or imply any endorsement, affiliation, sponsorship, or recommendation by any such third-party of Mini-Circuits or its products.

## Typical Performance Data

RF (IN) (MHz)	LO (MHz)	CONVERSION LOSS IF FIXED @IF (OUT)=30MHz (dB)		
		@LO (dBm)		
		+12	+15	+18
1000.1	1030.1	15.10	14.00	13.63
1180.1	1210.1	13.91	13.55	13.33
1380.1	1410.1	14.80	14.27	13.89
1580.1	1610.1	16.90	15.09	13.86
1780.1	1810.1	15.04	12.91	11.99
1980.1	2010.1	13.00	11.45	10.87
2180.1	2210.1	11.38	10.33	9.98
2380.1	2410.1	9.53	8.94	8.83
2600.1	2630.1	8.35	8.08	8.05
2760.1	2790.1	7.78	7.60	7.59
2960.1	2990.1	7.33	7.17	7.17
3160.1	3190.1	7.27	7.06	7.06
3360.1	3390.1	7.33	7.10	7.09
3560.1	3590.1	7.41	7.11	7.11
3820.1	3850.1	7.79	7.25	7.10
3960.1	3990.1	7.81	7.35	7.26
4160.1	4190.1	7.94	7.31	7.27
4360.1	4390.1	8.71	7.73	7.55
4540.1	4570.1	9.44	8.14	7.88
4740.1	4770.1	9.90	8.37	8.12
4940.1	4970.1	10.05	8.48	8.25
5140.1	5170.1	10.00	8.58	8.35
5340.1	5370.1	10.18	8.74	8.47
5540.1	5570.1	11.13	9.21	8.74
5740.1	5770.1	11.18	9.41	8.97
5940.1	5970.1	10.72	9.21	8.92
6120.1	6150.1	11.22	9.37	8.93
6320.1	6350.1	11.71	9.76	9.23
6520.1	6550.1	11.17	9.56	9.07
6720.1	6750.1	10.25	9.17	8.88
6920.1	6950.1	9.95	8.88	8.71
7120.1	7150.1	9.24	8.64	8.57
7320.1	7350.1	9.30	8.61	8.50
7520.1	7550.1	9.33	8.66	8.51
7720.1	7750.1	9.62	8.88	8.66
7900.1	7930.1	9.98	9.32	9.07
8100.1	8130.1	10.85	10.12	9.75
8300.1	8330.1	11.72	10.82	10.30
8500.1	8530.1	12.58	11.43	10.68
8700.1	8730.1	13.25	11.80	10.84
8900.1	8930.1	14.32	12.14	11.06
9100.1	9130.1	16.61	12.51	11.25
9300.1	9330.1	22.49	13.46	11.55
9500.1	9530.1	27.68	14.25	11.71

RF (IN) (MHz)	LO (MHz)	IP-3 INPUT (dBm)		
		@LO (dBm)		
		+12	+15	+18
1000.1	1030.1	15.26	19.87	19.60
1180.1	1210.1	17.50	23.89	24.02
1380.1	1410.1	15.60	15.35	17.26
1580.1	1610.1	10.33	13.39	18.60
1780.1	1810.1	12.09	19.05	24.50
1980.1	2010.1	14.61	19.33	23.21
2180.1	2210.1	13.27	15.94	17.48
2380.1	2410.1	13.80	18.42	19.87
2600.1	2630.1	13.82	15.70	16.97
2760.1	2790.1	12.56	14.21	15.92
2960.1	2990.1	14.41	16.13	17.30
3160.1	3190.1	14.77	15.38	16.97
3360.1	3390.1	15.70	16.35	17.29
3560.1	3590.1	20.46	18.11	17.52
3820.1	3850.1	12.21	14.53	19.07
3960.1	3990.1	13.05	15.45	19.39
4160.1	4190.1	19.16	20.03	25.49
4360.1	4390.1	18.16	24.21	24.05
4540.1	4570.1	15.42	24.85	23.01
4740.1	4770.1	16.06	20.52	21.09
4940.1	4970.1	16.41	18.69	21.20
5140.1	5170.1	23.31	19.09	20.88
5340.1	5370.1	23.50	24.38	23.11
5540.1	5570.1	17.88	22.41	25.99
5740.1	5770.1	16.99	19.96	20.65
5940.1	5970.1	17.01	26.66	20.68
6120.1	6150.1	18.16	22.64	24.70
6320.1	6350.1	18.52	24.88	23.28
6520.1	6550.1	17.92	21.70	22.01
6720.1	6750.1	21.02	22.92	22.85
6920.1	6950.1	18.71	21.81	23.21
7120.1	7150.1	18.61	22.12	23.61
7320.1	7350.1	19.38	23.60	24.51
7520.1	7550.1	19.23	22.00	24.72
7720.1	7750.1	18.94	21.92	22.52
7900.1	7930.1	19.45	20.02	24.06
8100.1	8130.1	19.26	19.25	22.85
8300.1	8330.1	17.73	19.55	22.58
8500.1	8530.1	18.55	21.41	25.19
8700.1	8730.1	19.38	24.33	24.98
8900.1	8930.1	22.22	20.01	23.39
9100.1	9130.1	11.58	20.49	21.00
9300.1	9330.1	6.25	14.27	16.18
9500.1	9530.1	9.95	11.09	16.34

RF (IN) (MHz)	LO (MHz)	COMPRESSION @RF IN=+10dBm (dB)		
		@LO (dBm)		
		+12	+15	+18
1000.1	1030.1	0.50	0.00	-0.04
1180.1	1210.1	-0.01	-0.05	0.00
1380.1	1410.1	-0.35	-0.28	-0.20
1580.1	1610.1	-1.75	-0.99	-0.42
1780.1	1810.1	-1.25	-0.33	-0.04
1980.1	2010.1	-0.44	-0.05	0.03
2180.1	2210.1	0.40	0.41	0.28
2380.1	2410.1	1.34	0.95	0.58
2600.1	2630.1	1.76	1.25	0.79
2760.1	2790.1	1.97	1.44	0.88
2960.1	2990.1	2.00	1.54	0.99
3160.1	3190.1	1.84	1.39	0.89
3360.1	3390.1	1.55	1.16	0.74
3560.1	3590.1	1.21	0.87	0.59
3820.1	3850.1	0.81	0.51	0.36
3960.1	3990.1	0.71	0.37	0.25
4160.1	4190.1	0.81	0.39	0.22
4360.1	4390.1	0.61	0.35	0.20
4540.1	4570.1	0.46	0.33	0.18
4740.1	4770.1	0.36	0.23	0.13
4940.1	4970.1	0.41	0.24	0.15
5140.1	5170.1	0.38	0.25	0.15
5340.1	5370.1	0.40	0.26	0.18
5540.1	5570.1	0.19	0.14	0.11
5740.1	5770.1	0.25	0.15	0.11
5940.1	5970.1	0.33	0.20	0.14
6120.1	6150.1	0.10	0.17	0.14
6320.1	6350.1	-0.07	0.12	0.14
6520.1	6550.1	0.16	0.27	0.24
6720.1	6750.1	0.47	0.38	0.29
6920.1	6950.1	0.89	0.42	0.31
7120.1	7150.1	1.03	0.37	0.27
7320.1	7350.1	1.02	0.36	0.21
7520.1	7550.1	0.94	0.38	0.19
7720.1	7750.1	0.95	0.42	0.21
7900.1	7930.1	0.95	0.45	0.24
8100.1	8130.1	0.90	0.49	0.31
8300.1	8330.1	0.79	0.43	0.31
8500.1	8530.1	0.60	0.34	0.33
8700.1	8730.1	0.62	0.39	0.44
8900.1	8930.1	0.78	0.51	0.54
9100.1	9130.1	0.74	0.72	0.57
9300.1	9330.1	-0.08	1.30	0.79
9500.1	9530.1	-1.76	1.24	0.98



P.O. Box 350166, Brooklyn, New York 11235-0003 (718) 934-4500 • Fax (718) 332-4661 For detailed performance specs & shopping online see Mini-Circuits web site



Provides ACTUAL Data Instantly From MINI-CIRCUITS At: [www.minicircuits.com](http://www.minicircuits.com)

IF/RF MICROWAVE COMPONENTS

REV. OR  
MDB-73H-D+  
5/9/2016

Page 1 of 4



## Typical Performance Data

IF (OUT) (MHz)	LO (MHz)	CONVERSION LOSS vs. IF FREQUENCY @RF (IN)=3200.1MHz (dB)	IF (OUT) (MHz)	LO (MHz)	CONVERSION LOSS vs. IF FREQUENCY @RF (IN)=2600.1MHz (dB)	IF (OUT) (MHz)	LO (MHz)	CONVERSION LOSS vs. IF FREQUENCY @RF (IN)=3800.1MHz (dB)
		@LO (dBm)			@LO (dBm)			@LO (dBm)
		+15			+15			+15
1850.0	1350.1	8.51	10.0	2610.1	7.98	2030.0	1770.1	9.79
1770.0	1430.1	8.49	40.0	2640.1	8.09	1990.0	1810.1	9.54
1680.0	1520.1	7.88	80.0	2680.1	8.22	1940.0	1860.1	9.27
1600.0	1600.1	7.90	120.0	2720.1	8.31	1890.0	1910.1	8.78
1510.0	1690.1	7.48	150.0	2750.1	8.33	1850.0	1950.1	8.63
1430.0	1770.1	7.64	190.0	2790.1	8.38	1800.0	2000.1	8.46
1340.0	1860.1	7.40	230.0	2830.1	8.41	1750.0	2050.1	8.42
1260.0	1940.1	7.28	260.0	2860.1	8.40	1710.0	2090.1	8.30
1170.0	2030.1	6.93	300.0	2900.1	8.37	1660.0	2140.1	8.09
1080.0	2120.1	6.66	340.0	2940.1	8.37	1610.0	2190.1	7.99
1000.0	2200.1	6.68	370.0	2970.1	8.34	1570.0	2230.1	7.89
910.0	2290.1	6.55	410.0	3010.1	8.33	1520.0	2280.1	7.78
830.0	2370.1	6.59	450.0	3050.1	8.32	1470.0	2330.1	7.70
740.0	2460.1	6.49	480.0	3080.1	8.31	1420.0	2380.1	7.69
660.0	2540.1	6.63	520.0	3120.1	8.33	1380.0	2420.1	7.67
570.0	2630.1	6.69	560.0	3160.1	8.33	1330.0	2470.1	7.62
490.0	2710.1	6.82	590.0	3190.1	8.36	1280.0	2520.1	7.54
400.0	2800.1	6.88	630.0	3230.1	8.45	1240.0	2560.1	7.46
310.0	2890.1	6.93	670.0	3270.1	8.53	1190.0	2610.1	7.46
230.0	2970.1	7.01	700.0	3300.1	8.62	1140.0	2660.1	7.40
140.0	3060.1	7.06	740.0	3340.1	8.73	1100.0	2700.1	7.39
60.0	3140.1	7.07	780.0	3380.1	8.80	1050.0	2750.1	7.40
10.0	3210.1	7.01	810.0	3410.1	8.90	1000.0	2800.1	7.40
50.0	3250.1	7.08	850.0	3450.1	8.97	950.0	2850.1	7.42
100.0	3300.1	7.13	890.0	3490.1	8.93	910.0	2890.1	7.41
140.0	3340.1	7.15	920.0	3520.1	8.97	860.0	2940.1	7.44
190.0	3390.1	7.20	960.0	3560.1	8.90	810.0	2990.1	7.49
240.0	3440.1	7.22	1000.0	3600.1	8.86	770.0	3030.1	7.51
280.0	3480.1	7.27	1030.0	3630.1	8.92	720.0	3080.1	7.54
330.0	3530.1	7.31	1070.0	3670.1	8.93	670.0	3130.1	7.54
380.0	3580.1	7.29	1110.0	3710.1	8.97	630.0	3170.1	7.51
420.0	3620.1	7.26	1140.0	3740.1	8.94	580.0	3220.1	7.47
470.0	3670.1	7.17	1180.0	3780.1	9.05	530.0	3270.1	7.44
520.0	3720.1	7.12	1220.0	3820.1	9.02	480.0	3320.1	7.37
560.0	3760.1	7.07	1250.0	3850.1	9.03	440.0	3360.1	7.33
610.0	3810.1	7.06	1290.0	3890.1	9.04	390.0	3410.1	7.26
660.0	3860.1	7.09	1330.0	3930.1	9.03	340.0	3460.1	7.21
700.0	3900.1	7.09	1360.0	3960.1	9.08	300.0	3500.1	7.16
750.0	3950.1	7.07	1400.0	4000.1	9.12	250.0	3550.1	7.15
800.0	4000.1	7.04	1440.0	4040.1	9.12	200.0	3600.1	7.17
840.0	4040.1	7.07	1470.0	4070.1	9.06	160.0	3640.1	7.20
890.0	4090.1	7.13	1510.0	4110.1	9.14	110.0	3690.1	7.19
940.0	4140.1	7.24	1550.0	4150.1	9.15	60.0	3740.1	7.19
980.0	4180.1	7.33	1590.0	4190.1	9.16	10.0	3790.1	7.15

# Frequency Mixer Die

# MDB-73H-D+

## Typical Performance Data

LO (MHz)	LO-RF ISOLATION (dB)			LO-IF ISOLATION (dB)			RF (IN) (MHz)	LO (MHz)	RF-IF ISOLATION (dB)		
	@LO (dBm)			@LO (dBm)					@LO (dBm)		
	+12	+15	+18	+12	+15	+18			+12	+15	+18
1030.1	34.62	37.84	40.47	36.55	33.18	32.98	1000.1	1030.1	12.78	13.90	14.44
1210.1	36.99	39.81	41.93	31.43	31.55	31.78	1180.1	1210.1	12.04	13.19	14.19
1410.1	38.96	41.18	43.01	31.60	31.84	32.11	1380.1	1410.1	12.12	12.94	13.55
1610.1	40.03	41.26	41.97	32.93	32.62	32.45	1580.1	1610.1	10.48	11.04	11.43
1810.1	40.55	40.88	40.82	34.71	33.29	32.23	1780.1	1810.1	10.02	10.42	10.78
2010.1	42.87	40.98	39.69	34.85	32.70	31.88	1980.1	2010.1	9.58	9.91	10.07
2210.1	42.02	39.52	38.18	35.47	33.35	32.34	2180.1	2210.1	9.75	9.75	9.70
2410.1	39.88	38.00	37.07	37.19	34.61	33.57	2380.1	2410.1	9.76	9.61	9.51
2630.1	38.24	37.82	37.60	39.39	37.62	36.69	2600.1	2630.1	9.68	9.61	9.56
2790.1	36.36	36.21	36.31	40.75	39.83	39.16	2760.1	2790.1	11.34	11.29	11.21
2990.1	36.97	36.57	36.44	41.32	41.36	41.46	2960.1	2990.1	12.20	12.19	12.10
3190.1	35.62	36.64	36.69	42.19	43.04	43.74	3160.1	3190.1	13.42	13.50	13.48
3390.1	33.40	34.08	35.14	42.39	43.87	45.48	3360.1	3390.1	13.94	13.98	13.94
3590.1	33.37	33.37	33.69	42.95	43.97	45.29	3560.1	3590.1	14.37	14.14	13.97
3850.1	37.21	36.40	35.57	45.41	46.34	46.99	3820.1	3850.1	15.16	14.70	14.39
3990.1	36.43	35.78	35.36	45.84	46.74	47.58	3960.1	3990.1	15.59	15.13	14.88
4190.1	38.15	37.55	36.82	46.74	47.84	48.44	4160.1	4190.1	16.17	15.57	15.36
4390.1	37.54	37.10	37.00	47.84	48.75	49.54	4360.1	4390.1	16.99	16.38	16.17
4570.1	39.04	37.70	37.22	48.85	49.30	49.83	4540.1	4570.1	17.28	16.81	16.62
4770.1	41.73	40.12	38.65	50.51	51.01	51.23	4740.1	4770.1	17.19	16.80	16.66
4970.1	43.38	40.33	38.43	51.73	51.92	51.84	4940.1	4970.1	16.30	16.04	15.94
5170.1	42.41	39.79	37.58	53.31	52.47	51.36	5140.1	5170.1	16.13	15.90	15.81
5370.1	39.37	38.70	37.23	55.66	53.62	51.59	5340.1	5370.1	15.73	15.54	15.47
5570.1	37.97	36.80	36.32	54.62	51.55	49.86	5540.1	5570.1	14.94	14.87	14.85
5770.1	38.16	36.33	35.68	52.41	49.45	47.75	5740.1	5770.1	15.07	15.04	15.09
5970.1	37.57	35.55	34.37	51.40	48.03	45.60	5940.1	5970.1	13.90	13.85	13.88
6150.1	35.96	34.93	33.76	48.96	45.89	43.27	6120.1	6150.1	12.98	12.99	13.03
6350.1	37.09	36.14	35.14	48.97	47.28	44.83	6320.1	6350.1	13.15	13.20	13.27
6550.1	36.48	35.52	34.40	47.05	45.27	43.22	6520.1	6550.1	12.22	12.32	12.40
6750.1	34.42	33.39	32.32	44.35	42.13	40.18	6720.1	6750.1	12.06	12.18	12.29
6950.1	34.63	33.48	32.45	44.17	41.69	39.81	6920.1	6950.1	12.65	12.78	12.88
7150.1	35.03	33.69	32.56	42.21	39.93	38.27	7120.1	7150.1	12.95	13.13	13.27
7350.1	34.02	33.07	31.97	38.83	36.52	34.90	7320.1	7350.1	13.05	13.30	13.47
7550.1	33.30	33.16	32.41	36.36	34.29	32.88	7520.1	7550.1	12.89	13.19	13.44
7750.1	35.62	36.50	36.08	34.58	32.58	31.12	7720.1	7750.1	11.58	11.96	12.26
7930.1	37.99	39.78	40.27	33.17	31.65	30.30	7900.1	7930.1	12.59	12.93	13.23
8130.1	41.86	39.78	37.88	31.96	30.63	29.35	8100.1	8130.1	12.08	12.39	12.65
8330.1	35.46	32.11	29.99	31.40	30.51	29.35	8300.1	8330.1	11.33	11.69	12.02
8530.1	29.64	27.41	25.76	30.54	30.04	28.90	8500.1	8530.1	11.97	12.47	12.91
8730.1	26.97	25.59	24.17	30.79	31.00	30.11	8700.1	8730.1	12.88	13.52	14.07
8930.1	25.12	24.36	23.06	29.95	30.90	30.47	8900.1	8930.1	12.99	13.65	14.25
9130.1	23.76	24.45	23.87	29.33	31.04	31.70	9100.1	9130.1	14.21	14.78	15.32
9330.1	21.21	21.82	21.37	28.53	29.89	30.22	9300.1	9330.1	14.39	14.87	15.37
9530.1	20.34	21.13	20.70	27.68	29.20	29.22	9500.1	9530.1	15.59	15.91	16.23



P.O. Box 350166, Brooklyn, New York 11235-0003 (718) 934-4500 • Fax (718) 332-4661 For detailed performance specs & shopping online see Mini-Circuits web site



The Design Engineers Search Engine Provides ACTUAL Data Instantly From MINI-CIRCUITS At: [www.minicircuits.com](http://www.minicircuits.com)

IF/RF MICROWAVE COMPONENTS

REV. OR  
MDB-73H-D+  
5/9/2016

Page 3 of 4

# Frequency Mixer Die

# MDB-73H-D+

## Typical Performance Data

RF (IN) (MHz)	LO (MHz)	RF VSWR (:1)			LO (MHz)	LO VSWR (:1)			LO (MHz)	IF VSWR @LO=3800.1MHz (:1)		
		@LO (dBm)				@LO (dBm)				@LO (dBm)		
		+12	+15	+18		+12	+15	+18		+12	+15	+18
1000.1	1030.1	7.33	6.92	6.77	1030.1	6.54	5.24	5.17	10.1	2.23	1.92	1.77
1180.1	1210.1	6.56	6.58	6.61	1210.1	2.88	3.10	3.43	90.1	2.31	1.99	1.84
1380.1	1410.1	6.96	7.08	7.14	1410.1	1.68	2.12	2.40	180.1	2.24	1.94	1.79
1580.1	1610.1	7.30	7.26	7.18	1610.1	1.24	1.62	1.91	270.1	2.09	1.81	1.66
1780.1	1810.1	6.68	6.42	6.23	1810.1	1.16	1.34	1.58	360.1	2.06	1.79	1.65
1980.1	2010.1	5.79	5.52	5.36	2010.1	1.31	1.18	1.37	440.1	1.96	1.71	1.57
2180.1	2210.1	4.77	4.54	4.40	2210.1	1.45	1.14	1.24	530.1	1.82	1.59	1.46
2380.1	2410.1	3.56	3.44	3.39	2410.1	1.56	1.14	1.17	620.1	1.68	1.48	1.36
2600.1	2630.1	2.63	2.62	2.62	2630.1	1.60	1.19	1.17	710.1	1.54	1.35	1.25
2760.1	2790.1	2.06	2.06	2.08	2790.1	1.62	1.20	1.17	800.1	1.32	1.17	1.09
2960.1	2990.1	1.54	1.52	1.53	2990.1	1.73	1.27	1.19	880.1	1.23	1.12	1.09
3160.1	3190.1	1.25	1.27	1.28	3190.1	1.84	1.40	1.26	970.1	1.12	1.12	1.18
3360.1	3390.1	1.17	1.29	1.34	3390.1	1.98	1.51	1.32	1060.1	1.14	1.23	1.31
3560.1	3590.1	1.15	1.31	1.43	3590.1	2.15	1.60	1.36	1150.1	1.25	1.38	1.48
3820.1	3850.1	1.31	1.38	1.44	3850.1	2.42	1.73	1.40	1240.1	1.34	1.48	1.59
3960.1	3990.1	1.40	1.48	1.52	3990.1	2.64	1.83	1.41	1320.1	1.48	1.63	1.76
4160.1	4190.1	1.49	1.49	1.50	4190.1	3.19	2.10	1.54	1410.1	1.57	1.71	1.84
4360.1	4390.1	1.80	1.68	1.63	4390.1	3.40	2.29	1.65	1500.1	1.70	1.83	1.95
4540.1	4570.1	2.11	1.97	1.90	4570.1	3.67	2.43	1.76	1590.1	1.78	1.88	2.01
4740.1	4770.1	2.40	2.25	2.17	4770.1	4.10	2.67	1.87	1680.1	1.90	1.96	2.06
4940.1	4970.1	2.64	2.46	2.36	4970.1	4.30	2.82	2.00	1760.1	1.95	1.95	2.01
5140.1	5170.1	2.83	2.59	2.46	5170.1	4.54	2.96	2.11	1850.1	2.07	1.97	1.97
5340.1	5370.1	2.92	2.66	2.53	5370.1	4.47	2.98	2.21	1940.1	2.24	2.05	1.97
5540.1	5570.1	3.09	2.78	2.65	5570.1	4.61	3.11	2.34	2030.1	2.45	2.17	2.02
5740.1	5770.1	3.15	2.86	2.74	5770.1	4.48	3.09	2.45	2110.1	2.73	2.38	2.17
5940.1	5970.1	3.09	2.78	2.64	5970.1	4.58	3.22	2.59	2200.1	3.03	2.65	2.40
6120.1	6150.1	3.13	2.82	2.65	6150.1	4.31	3.21	2.69	2290.1	3.42	3.02	2.75
6320.1	6350.1	3.20	2.93	2.78	6350.1	4.15	3.22	2.83	2380.1	3.76	3.40	3.16
6520.1	6550.1	3.07	2.82	2.66	6550.1	4.06	3.32	3.03	2470.1	4.18	3.89	3.71
6720.1	6750.1	2.85	2.58	2.44	6750.1	3.99	3.42	3.16	2550.1	4.57	4.35	4.25
6920.1	6950.1	2.62	2.35	2.21	6950.1	3.75	3.36	3.27	2640.1	5.07	4.98	4.98
7120.1	7150.1	2.37	2.13	1.99	7150.1	3.40	3.22	3.21	2730.1	5.52	5.56	5.68
7320.1	7350.1	2.21	1.98	1.82	7350.1	3.10	3.08	3.25	2820.1	6.10	6.28	6.51
7520.1	7550.1	2.10	1.88	1.71	7550.1	2.82	2.99	3.30	2910.1	6.65	6.96	7.27
7720.1	7750.1	1.95	1.76	1.60	7750.1	2.63	2.85	3.17	2990.1	7.20	7.62	8.00
7900.1	7930.1	1.69	1.57	1.45	7930.1	2.57	2.84	3.25	3080.1	7.70	8.19	8.60
8100.1	8130.1	1.59	1.49	1.39	8130.1	2.53	2.82	3.22	3170.1	8.37	8.94	9.33
8300.1	8330.1	1.47	1.39	1.32	8330.1	2.50	2.78	3.11	3260.1	8.90	9.43	9.82
8500.1	8530.1	1.41	1.35	1.30	8530.1	2.43	2.72	3.09	3350.1	9.62	10.09	10.40
8700.1	8730.1	1.43	1.38	1.34	8730.1	2.42	2.65	2.98	3430.1	10.08	10.50	10.74
8900.1	8930.1	1.52	1.50	1.47	8930.1	2.38	2.58	2.87	3520.1	10.51	10.77	10.94
9100.1	9130.1	1.68	1.67	1.66	9130.1	2.29	2.44	2.67	3610.1	11.18	11.42	11.54
9300.1	9330.1	1.87	1.86	1.84	9330.1	2.18	2.26	2.46	3700.1	11.58	11.70	11.77
9500.1	9530.1	2.12	2.07	2.00	9530.1	1.99	2.05	2.17	3790.1	12.65	12.72	12.65



P.O. Box 350166, Brooklyn, New York 11235-0003 (718) 934-4500 • Fax (718) 332-4661 For detailed performance specs & shopping online see Mini-Circuits web site



The Design Engineers Search Engine Provides ACTUAL Data Instantly From MINI-CIRCUITS At: www.minicircuits.com

IF/RF MICROWAVE COMPONENTS

REV. OR  
MDB-73H-D+  
5/9/2016

Page 4 of 4

# Frequency Mixer Die

## Typical Performance Curves

**MDB-73H-D+**

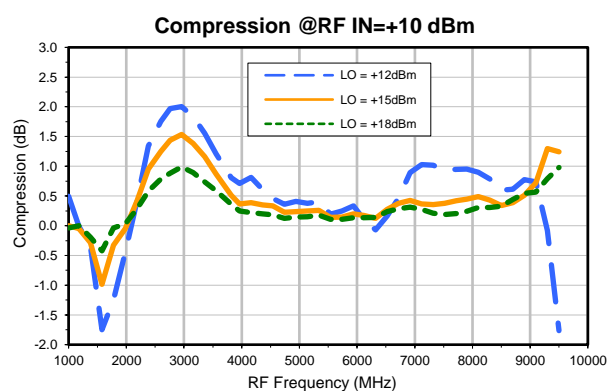
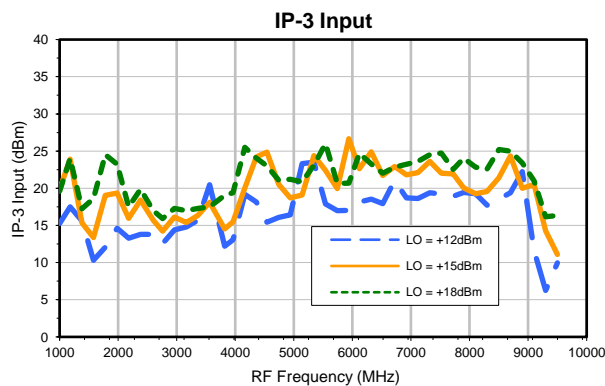
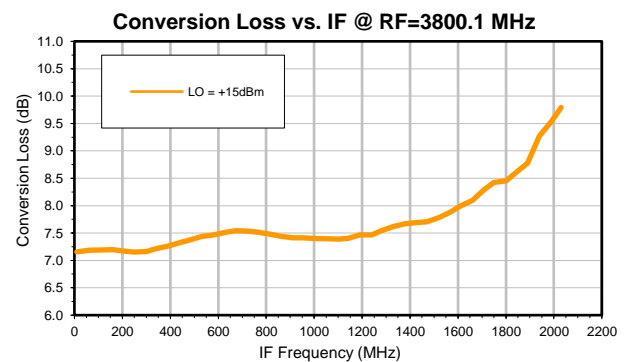
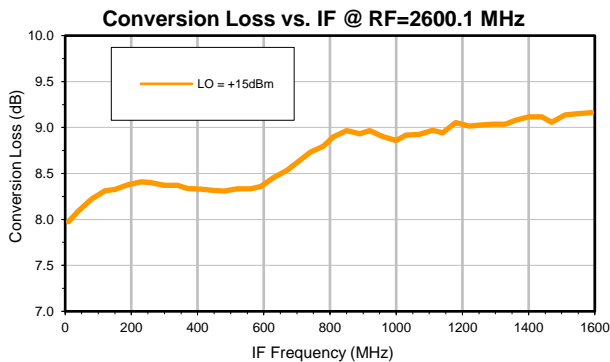
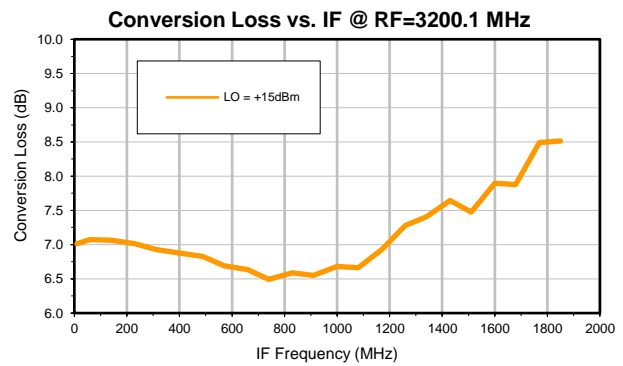
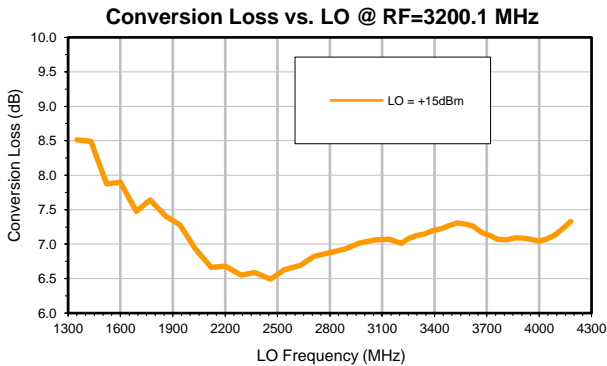
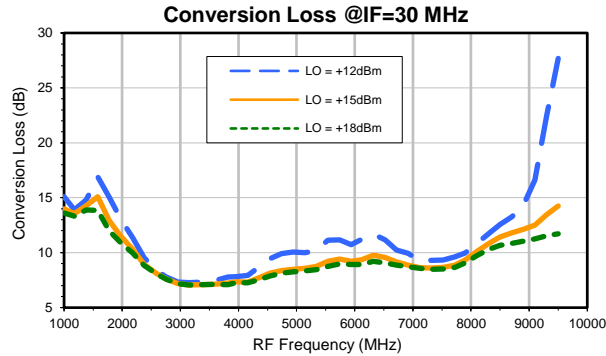

P.O. Box 350166, Brooklyn, New York 11235-0003 (718) 934-4500 • Fax (718) 332-4661 For detailed performance specs & shopping online see Mini-Circuits web site



The Design Engineers Search Engine Provides ACTUAL Data Instantly From MINI-CIRCUITS At: [www.minicircuits.com](http://www.minicircuits.com)

IF/RF MICROWAVE COMPONENTS

REV. OR  
MDB-73H-D+  
5/9/2016  
Page 1 of 2

# Frequency Mixer Die

## Typical Performance Curves

MDB-73H-D+

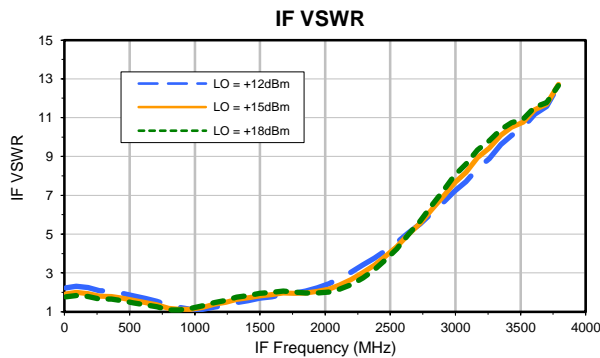
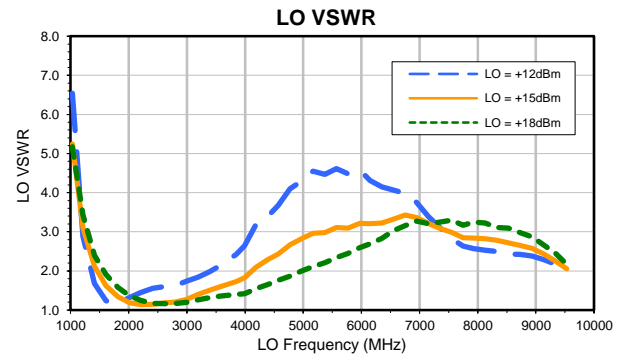
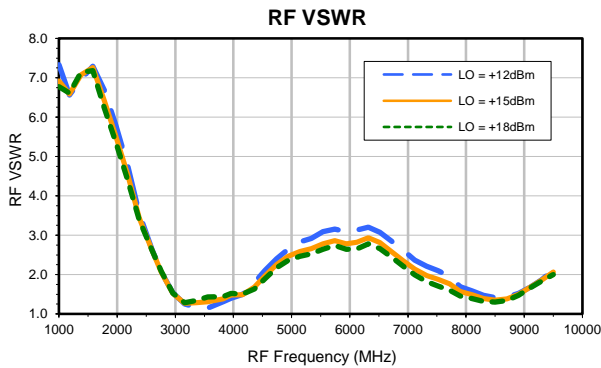
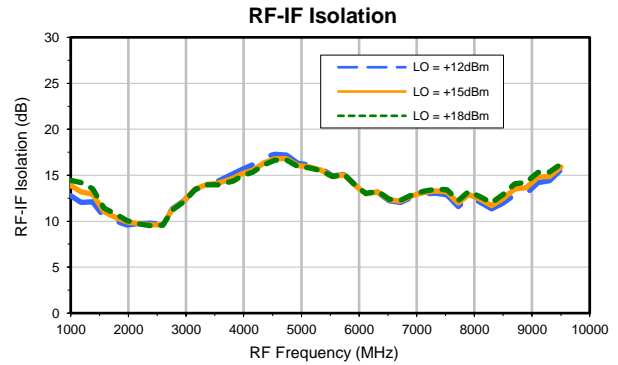
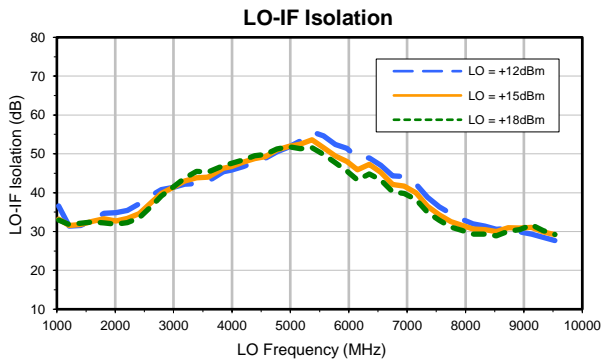
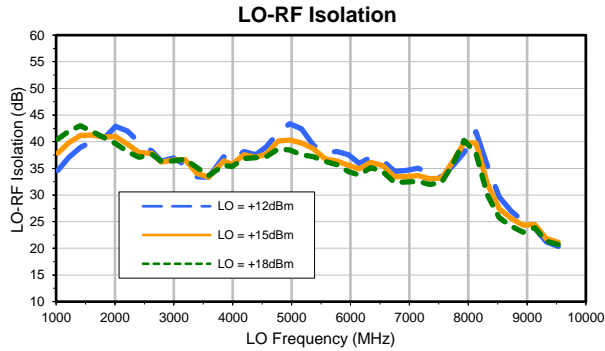

**Mini-Circuits**  
ISO 9001 ISO 14001 AS 9100 CERTIFIED

[minicircuits.com](http://minicircuits.com)

P.O. Box 350166, Brooklyn, New York 11235-0003 (718) 934-4500 • Fax (718) 332-4661 For detailed performance specs & shopping online see Mini-Circuits web site



The Design Engineers Search Engine Provides ACTUAL Data Instantly From MINI-CIRCUITS At: [www.minicircuits.com](http://www.minicircuits.com)

IF/RF MICROWAVE COMPONENTS

REV. OR  
MDB-73H-D+  
5/9/2016  
Page 2 of 2



All Mini-Circuits products are manufactured under exacting quality assurance and control standards, and are capable of meeting published specifications after being subjected to any or all of the following physical and environmental test.

<b>Specification</b>	<b>Test/Inspection Condition</b>	<b>Reference/Spec</b>
Operating Temperature	-40° to 85° C or -40° to 105° C or -55° to 105° C or -45° to 105° C Ambient Environment	Refer to Individual Model Data Sheet
Storage Environment (Die)	-65° to 150°C	Individual Model Data Sheet
Storage Environment(Packaging)	-40° to 70°C and 40 to 60% humidity (In Factory Shipped Package)	