



MMIC SURFACE MOUNT WIDEBAND

Double Balanced Mixer

MDB-44H+

Mini-Circuits

Level 15 (LO Power 15dBm) 10-40 GHz

THE BIG DEAL

- Wide bandwidth 10 to 40 GHz
- High L-R Isolation, 37 dB typ. at 25 GHz
- Useable as Up & Down Converter
- Small Size, 3 mm x 3 mm x 0.89 mm
- Aqueous washable

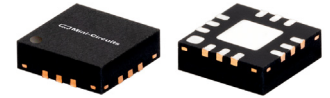

CASE STYLE: DQ1225

Generic photo used for illustration purposes only

+RoHS Compliant

The +Suffix identifies RoHS Compliance. See our web site for RoHS Compliance methodologies and qualifications

APPLICATIONS

- Satellite up and down converters
- Defense radar & communication
- VSAT
- Line of sight links
- Federal fixed service
- 5G
- ISM

PRODUCT OVERVIEW

MDB-44H+ is an advanced wideband frequency mixer fabricated using InGaP HBT technology with integrated LO and RF Baluns. It has repeatable performance making it suitable for volume production. It is packaged in tiny 3 mm x 3 mm x 0.89 mm MCLP™ package.

KEY FEATURES

Feature	Advantages
Double Balanced	Results in excellent LO-RF (30-39 dB typical) & LO-IF (27-37 dB typical) Isolations mini-mizing need for external filtering
Wide Bandwidth, 10 to 40 GHz	Useful in wideband systems or in several narrowband systems. Reducing inventory
Wide IF Bandwidth DC-15 GHz	Usable in first and second down converter applications. IF as low as DC enables use in phase detector applications.
3 mm x 3 mm, 12 lead MCLP Package	Low Inductance, repeatable transitions, excellent thermal contact to PCB

REV. B
ECO-009182
MDB-44H+
MCL NY
210809



ELECTRICAL SPECIFICATIONS¹ AT 25°C, UNLESS NOTED

Parameter	Condition (GHz)	Min.	Typ.	Max.	Units
RF Frequency Range	-	10	-	40	GHz
LO Frequency Range	-	10	-	40	GHz
IF Frequency Range	-	DC	-	15	GHz
LO Power	-	+15			dBm
Conversion Loss (at IF=30 MHz)	10-20	-	8.0	-	dB
	20-30	-	8.4	11.0	
	30-40	-	8.9	13.4	
LO-RF Isolation	10-20	-	39	-	dB
	20-30	25	37	-	
	30-40	-	30	-	
LO-IF Isolation	10-20	-	33	-	dB
	20-30	20	37	-	
	30-40	-	27	-	
RF-IF Isolation	10-20	-	24	-	dB
	20-30	-	16	-	
	30-40	-	31	-	
Input at 1dB Compression	10-40	-	10	-	dBm
Input IP3	10-20	-	20	-	dBm
Noise Figure	20	-	8.6	-	dB
Thermal Resistance (junction-to-ground lead)		-	105	-	°C/W

1. Measured on Mini-Circuits Characterization test board TB-973-MDB44HC+. See Characterization Test Circuit Figure 1

MAXIMUM RATINGS²

Parameter	Ratings
Operating Temperature	-40°C to 85°C
Storage Temperature	-65°C to 150°C
RF Power	21 dBm
LO Power	21 dBm
IF Current	30 mA

2. Permanent damage may occur if any of these limits are exceeded. Electrical maximum ratings are not intended for continuous normal operation.



SIMPLIFIED SCHEMATIC AND BONDING PAD DESCRIPTION

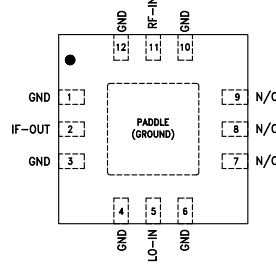
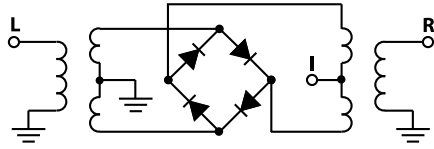

PAD CONNECTIONS

Function	Pad Number	Description
RF-IN	11	RF input
LO-IN	5	LO input
IF-OUT	2	IF output
GND	1,3,4,6,10,12, Paddle	Connect to Ground
NC	7-9	No connection, not used

CHARACTERIZATION TEST CIRCUITS

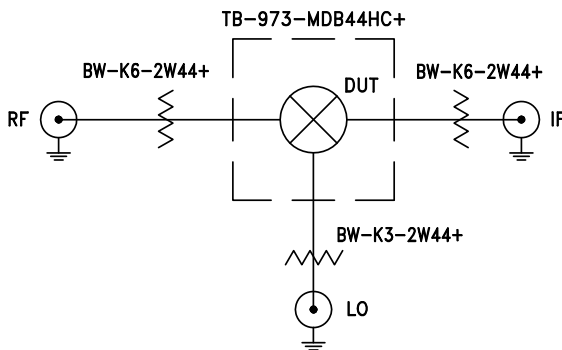

Figure 1A. Block Diagram of Test Circuit used for characterization of Conversion Loss, Isolations (LO-RF, LO-IF, RF-IF) and Return Loss (LO, RF, IF)

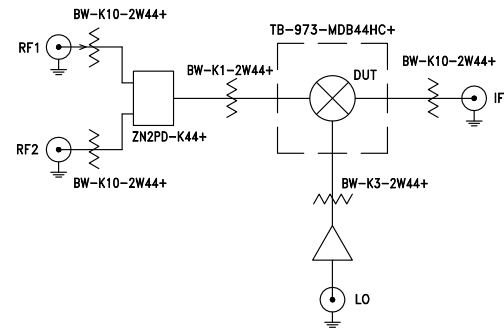

Figure 1B. Block Diagram of Test Circuit used for characterization of Input IP3

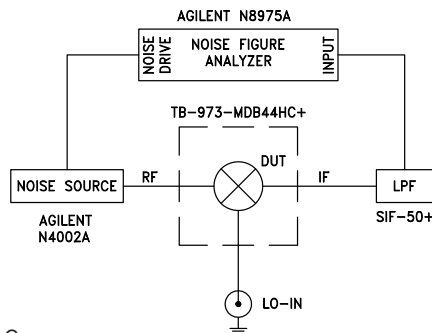
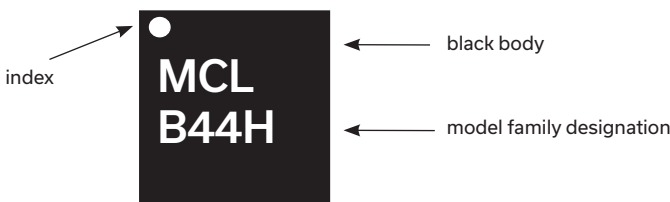

Figure 1C. Block Diagram of Test Circuit used for characterization of Noise Figure

Figure 1. Block Diagram of Test Circuit used for characterization. (DUT soldered on Mini-Circuits Characterization test board TB-973-MDB44HC+). Conversion Loss, Isolations L-R, L-I & R-I, Input IP3 are measured using Agilent PSA E4448A spectrum Analyzer and PSG E8257D Signal Generators. NF is measured using Agilent's N8975A NF Analyzer.

- Conditions (Down Converter):
1. Conversion Loss, Isolations (L-R, L-I & R-I): RF= 0 dBm, LO=+15 dBm, IF=30 MHz
 2. Output IP3 (OIP3): Two tones, spaced 1 MHz apart, 0 dBm/tone at output.
 3. Noise Figure: LO=+15 dBm

PRODUCT MARKING



APPLICATION CIRCUIT

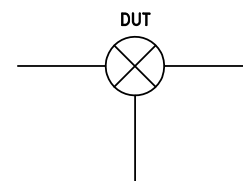



ADDITIONAL DETAILED TECHNICAL INFORMATION IS AVAILABLE ON OUR DASH BOARD. TO ACCESS [CLICK HERE](#)

Performance Data	Data Table Swept Graphs S-Parameter (S1P Files) Data Set (.zip file)
Case Style	DQ1225 Plastic package, exposed paddle, lead finish: matte-tin
Tape & Reel Standard quantities available on reel	F66 7" reels with 20, 50, 100, 200, 500, 1K and 2K devices
Suggested Layout for PCB Design	PL-540
Evaluation Board	TB-973-MDB44HC+
Environmental Ratings	ENV08T1

ESD RATING

Human Body Model (HBM): Class 1A (250 to <500V) in accordance with ANSI/ESD STM 5.1 - 2001

MSL RATING

Moisture Sensitivity: MSL1 in accordance with IPC/JEDEC J-STD-020D

MSL TEST FLOW CHART

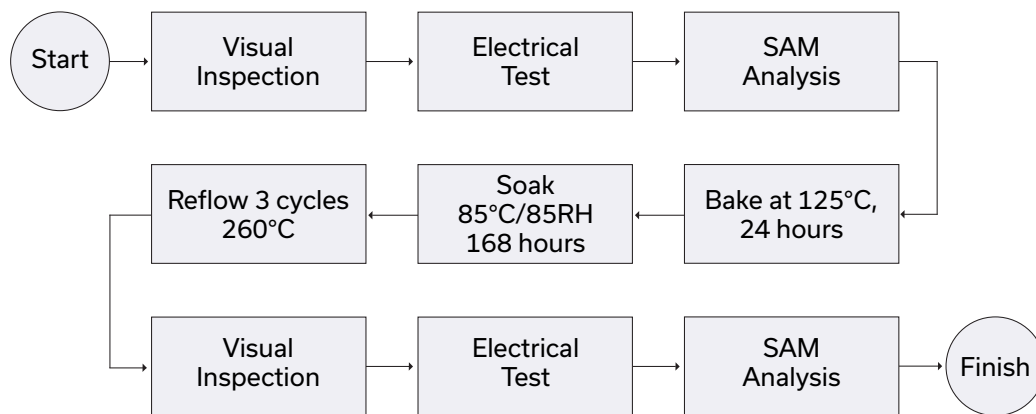

- NOTES
- A. Performance and quality attributes and conditions not expressly stated in this specification document are intended to be excluded and do not form a part of this specification document.
 - B. Electrical specifications and performance data contained in this specification document are based on Mini-Circuit's applicable established test performance criteria and measurement instructions.
 - C. The parts covered by this specification document are subject to Mini-Circuits standard limited warranty and terms and conditions (collectively, "Standard Terms"); Purchasers of this part are entitled to the rights and benefits contained therein. For a full statement of the standard. Terms and the exclusive rights and remedies thereunder, please visit Mini-Circuits' website at www.minicircuits.com/MCLStore/terms.jsp

Wideband Double Balanced Mixer

MDB-44H+

Typical Performance Data

RF (IN) (MHz)	LO (MHz)	CONVERSION LOSS IF FIXED @ IF(OUT)=30MHz (dB)			RF (IN) (MHz)	LO (MHz)	CONVERSION LOSS IF FIXED @ IF(OUT)=2000MHz (dB)			RF (IN) (MHz)	LO (MHz)	CONVERSION LOSS IF FIXED @ IF(OUT)=3000MHz (dB)		
		@LO (dBm)					@LO (dBm)					@LO (dBm)		
		+14	+15	+18			+14	+15	+18			+14	+15	+18
8000	7970	24.10	22.43	20.40	8000	6000	--	52.49	--	8000	5000	--	52.74	--
8800	8770	19.55	18.68	17.65	8800	6800	--	29.44	--	8800	5800	--	46.34	--
9600	9570	14.47	14.18	13.81	9600	7600	--	22.66	--	9600	6600	--	39.34	--
10400	10370	10.55	10.31	10.28	10400	8400	--	13.35	--	10400	7400	--	16.70	--
11200	11170	7.93	7.69	7.69	11200	9200	--	5.87	--	11200	8200	--	6.94	--
12000	11970	6.83	6.67	6.76	12000	10000	--	6.22	--	12000	9000	--	6.95	--
12900	12870	6.51	6.28	6.20	12900	10900	--	6.73	--	12900	9900	--	6.62	--
13700	13670	7.37	7.13	7.12	13700	11700	--	7.52	--	13700	10700	--	7.25	--
14500	14470	7.91	7.81	7.80	14500	12500	--	8.69	--	14500	11500	--	7.99	--
15300	15270	8.28	8.22	8.03	15300	13300	--	9.82	--	15300	12300	--	8.84	--
16100	16070	8.62	8.48	8.37	16100	14100	--	9.99	--	16100	13100	--	9.34	--
16900	16870	8.83	8.70	8.54	16900	14900	--	9.71	--	16900	13900	--	10.04	--
17800	17770	8.60	8.59	8.54	17800	15800	--	9.40	--	17800	14800	--	10.11	--
18600	18570	7.76	7.69	7.77	18600	16600	--	8.68	--	18600	15600	--	9.60	--
19400	19370	7.67	7.49	7.41	19400	17400	--	7.77	--	19400	16400	--	9.10	--
20200	20170	7.49	7.55	7.85	20200	18200	--	7.38	--	20200	17200	--	8.09	--
21000	20970	7.45	7.43	7.68	21000	19000	--	7.95	--	21000	18000	--	8.15	--
21900	21870	7.93	7.82	7.87	21900	19900	--	8.12	--	21900	18900	--	8.48	--
22700	22670	7.33	7.31	7.63	22700	20700	--	8.05	--	22700	19700	--	8.25	--
23500	23470	7.84	7.55	7.52	23500	21500	--	8.00	--	23500	20500	--	8.09	--
24300	24270	7.98	7.74	7.81	24300	22300	--	8.35	--	24300	21300	--	8.32	--
25100	25070	8.42	8.12	8.15	25100	23100	--	9.62	--	25100	22100	--	9.23	--
25900	25870	9.33	9.07	8.89	25900	23900	--	10.51	--	25900	22900	--	10.40	--
26800	26770	9.91	9.85	10.09	26800	24800	--	10.58	--	26800	23800	--	10.56	--
27600	27570	9.68	9.61	9.74	27600	25600	--	10.52	--	27600	24600	--	11.28	--
28400	28370	9.45	9.17	9.42	28400	26400	--	10.33	--	28400	25400	--	10.72	--
29200	29170	8.90	8.85	9.24	29200	27200	--	9.77	--	29200	26200	--	10.14	--
30000	29970	9.05	8.96	9.20	30000	28000	--	9.12	--	30000	27000	--	9.78	--
30900	30870	8.93	9.09	9.20	30900	28900	--	9.22	--	30900	27900	--	9.49	--
31700	31670	9.16	9.05	9.32	31700	29700	--	9.69	--	31700	28700	--	9.67	--
32500	32470	9.41	9.59	9.93	32500	30500	--	10.10	--	32500	29500	--	10.21	--
33300	33270	8.78	9.30	9.60	33300	31300	--	9.72	--	33300	30300	--	9.96	--
34100	34070	8.59	9.01	9.20	34100	32100	--	9.27	--	34100	31100	--	9.32	--
34900	34870	8.45	8.75	8.66	34900	32900	--	9.26	--	34900	31900	--	9.18	--
35800	35770	8.02	8.48	8.66	35800	33800	--	9.25	--	35800	32800	--	9.43	--
36600	36570	8.88	9.16	8.96	36600	34600	--	9.95	--	36600	33600	--	10.13	--
37400	37370	9.59	10.08	9.93	37400	35400	--	10.71	--	37400	34400	--	10.74	--
38200	38170	9.64	10.20	10.21	38200	36200	--	11.40	--	38200	35200	--	11.14	--
39000	38970	10.26	10.64	10.44	39000	37000	--	11.83	--	39000	36000	--	11.92	--
39900	39870	10.39	10.84	11.02	39900	37900	--	13.31	--	39900	36900	--	13.10	--



P.O. Box 350166, Brooklyn, New York 11235-0003 • (718) 934-4500 • Fax (718) 332-4661 For detailed performance specs & shopping online see Mini-Circuits web site



The Design Engineers Search Engine Provides ACTUAL Data Instantly From MINI-CIRCUITS At: www.minicircuits.com

IF/RF MICROWAVE COMPONENTS

REV. OR
MDB-44H+
1/10/2018
Page 1 of 6

Typical Performance Data

RF (IN) (MHz)	LO (MHz)	IP-3 INPUT (dBm)			RF (IN) (MHz)	LO (MHz)	COMPRESSION @ RF IN=+10dBm (dB)		
		@LO (dBm)					@LO (dBm)		
		+14	+15	+18			+14	+15	+18
8000	8030	22.19	24.82	33.70	8000	8030	-0.62	-0.48	-0.27
8300	8330	23.42	25.35	31.89	8800	8830	-0.65	-0.53	-0.32
8600	8630	24.97	27.18	32.78	9600	9630	-0.25	-0.24	-0.17
8900	8930	26.75	28.38	31.67	10400	10430	0.24	0.25	0.26
9200	9230	26.79	27.93	30.04	11200	11230	1.26	1.14	0.84
9500	9530	26.07	26.40	27.05	12000	12030	0.80	0.71	0.46
9800	9830	24.41	24.47	24.64	12900	12930	0.73	0.66	0.53
10100	10130	21.34	21.44	21.84	13700	13730	0.14	0.15	0.20
10450	10480	19.78	20.01	20.50	14500	14530	0.06	0.06	0.04
10750	10780	18.33	18.59	19.14	15300	15330	-0.05	-0.12	-0.06
11050	11080	16.40	16.73	17.27	16100	16130	-0.02	-0.03	0.05
11350	11380	15.89	16.20	16.49	16900	16930	-0.05	-0.01	-0.03
11650	11680	15.46	15.75	16.27	17800	17830	0.02	0.06	0.03
11950	11980	15.24	15.59	16.07	18600	18630	0.17	0.18	0.13
12250	12280	15.04	15.38	15.94	19400	19430	0.18	0.20	0.17
12550	12580	15.71	16.11	16.60	20200	20230	0.18	0.18	0.25
12900	12930	16.65	17.06	17.64	21000	21030	0.09	0.12	0.12
13200	13230	17.81	18.07	18.60	21900	21930	0.07	0.09	0.10
13500	13530	19.25	19.55	19.90	22700	22730	0.12	0.14	0.14
13800	13830	18.88	19.41	19.96	23500	23530	0.01	0.10	0.11
14100	14130	19.47	19.70	20.25	24300	24330	0.05	0.05	0.17
14400	14430	19.12	19.69	20.64	25100	25130	0.02	0.05	0.05
14700	14730	19.38	19.57	20.83	25900	25930	0.03	-0.01	0.11
15000	15030	21.49	21.68	22.54	26800	26830	0.01	-0.07	0.00
15350	15380	19.95	20.00	21.40	27600	27630	-0.02	0.00	0.03
15650	15680	22.06	21.70	21.70	28400	28430	0.07	0.06	0.15
15950	15980	22.54	22.35	22.35	29200	29230	0.11	0.15	0.33
16250	16280	21.32	21.11	20.77	30000	30030	0.00	0.07	0.19
16550	16580	24.22	23.59	21.85	30900	30930	0.00	0.08	0.25
16850	16880	24.14	24.21	22.66	31700	31730	0.12	0.14	0.24
17150	17180	23.07	23.37	22.25	32500	32530	0.17	0.22	0.28
17450	17480	24.04	24.33	23.04	33300	33330	0.22	0.26	0.24
17800	17830	23.68	23.71	22.12	34100	34130	0.27	0.26	0.20
18100	18130	21.06	20.94	19.76	34900	34930	0.24	0.28	0.28
18400	18430	20.62	20.26	19.13	35800	35830	0.32	0.26	0.11
18700	18730	19.67	19.53	18.80	36600	36630	0.19	0.04	0.05
19000	19030	19.10	19.10	18.61	37400	37430	0.00	0.01	0.05
19300	19330	20.02	20.15	19.55	38200	38230	0.18	0.10	0.28
19600	19630	19.08	19.24	18.83	39000	39030	0.25	0.16	0.40
19950	19980	19.54	19.57	19.37	39900	39930	0.19	0.13	0.36

Typical Performance Data

IF (MHz)	LO (MHz)	CONVERSION LOSS VS. IF FREQUENCY @ RF=20000MHz (dB)	IF (MHz)	RF (MHz)	CONVERSION LOSS VS. IF FREQUENCY @ LO=20000MHz (dB)
		@LO (dBm)			@LO (dBm)
		+15			+15
10	20010	8.77	10	20010	8.70
60	20060	8.55	60	20060	8.35
200	20200	8.47	200	20200	8.52
700	20700	8.58	700	20700	8.48
1300	21300	8.62	1300	21300	8.38
1800	21800	8.88	1800	21800	8.18
2300	22300	8.99	2300	22300	8.94
2900	22900	8.94	2900	22900	8.06
3400	23400	8.97	3400	23400	9.03
3900	23900	9.14	3900	23900	9.61
4500	24500	9.45	4500	24500	9.63
5000	25000	9.38	5000	25000	10.40
5500	25500	9.52	5500	25500	10.89
6100	26100	9.66	6100	26100	12.48
6600	26600	9.69	6600	26600	13.21
7100	27100	10.35	7100	27100	14.09
7600	27600	10.39	7600	27600	14.48
8200	28200	11.01	8200	28200	14.23
8700	28700	11.48	8700	28700	14.09
9200	29200	11.19	9200	29200	12.70
9800	29800	11.35	9800	29800	11.84
10300	30300	11.33	10300	30300	10.82
10800	30800	10.92	10800	30800	10.90
11400	31400	11.20	11400	31400	11.08
11900	31900	11.18	11900	31900	10.96
12400	32400	10.99	12400	32400	11.42
13000	33000	11.16	13000	33000	11.40
13500	33500	11.44	13500	33500	12.12
14000	34000	12.25	14000	34000	12.75
14500	34500	13.83	14500	34500	13.49
15100	35100	15.66	15100	35100	14.59
15600	35600	16.84	15600	35600	15.42
16100	36100	17.32	16100	36100	15.88
16700	36700	18.66	16700	36700	17.67
17200	37200	19.99	17200	37200	19.72
17700	37700	21.29	17700	37700	21.38
18300	38300	23.32	18300	38300	23.25
18800	38800	24.88	18800	38800	24.63
19300	39300	26.44	19300	39300	25.94
19900	39900	28.56	19900	39900	28.81

Wideband Double Balanced Mixer MDB-44H+

Typical Performance Data

LO (MHz)	LO-RF ISOLATION (dB)			LO-IF ISOLATION (dB)			RF (IN) (MHz)	LO (MHz)	RF-IF ISOLATION (dB)		
	@LO (dBm)			@LO (dBm)					@LO (dBm)		
	+14	+15	+18	+14	+15	+18			+14	+15	+18
8030	55.46	54.48	53.11	26.56	26.48	26.87	8000	8030	29.56	30.14	30.98
8830	53.36	53.39	53.85	25.67	25.82	26.60	8800	8830	29.01	29.50	30.21
9630	47.86	48.42	50.31	26.23	26.44	26.84	9600	9630	26.80	27.07	27.68
10430	43.59	44.38	46.84	28.41	28.50	28.91	10400	10430	23.84	24.14	24.46
11230	40.03	40.60	42.23	29.92	29.83	29.47	11200	11230	21.21	21.50	21.84
12030	37.87	37.89	37.84	30.67	30.73	29.17	12000	12030	20.35	20.59	20.69
12930	38.89	39.00	39.29	32.41	32.42	31.09	12900	12930	20.52	20.75	20.75
13730	38.09	37.98	37.65	29.87	30.04	29.07	13700	13730	21.76	21.89	21.60
14530	39.60	39.58	39.47	31.79	32.58	32.19	14500	14530	23.13	23.21	23.16
15330	40.48	40.40	40.28	31.59	32.78	33.61	15300	15330	24.81	24.87	24.50
16130	38.88	38.92	38.83	31.83	32.44	33.14	16100	16130	25.33	25.34	25.08
16930	39.21	39.46	40.05	32.27	33.48	35.53	16900	16930	26.00	25.96	25.43
17830	38.32	38.66	39.77	33.43	34.48	36.60	17800	17830	27.12	26.96	26.38
18630	37.42	37.72	38.15	34.26	35.04	36.50	18600	18630	25.66	25.47	24.94
19430	36.84	37.59	38.62	35.66	36.58	38.39	19400	19430	24.14	23.92	23.53
20230	37.39	37.79	38.54	37.69	38.10	39.37	20200	20230	21.76	21.58	21.26
21030	37.41	38.14	39.25	40.85	41.64	43.13	21000	21030	20.72	20.57	20.29
21930	36.91	37.50	37.79	48.72	49.29	50.40	21900	21930	19.62	19.52	19.32
22730	35.80	36.27	36.74	54.72	54.22	52.06	22700	22730	18.31	18.31	18.30
23530	36.32	36.88	37.06	44.36	44.43	43.99	23500	23530	16.92	16.98	17.03
24330	36.23	36.90	37.02	38.13	38.47	38.96	24300	24330	16.37	16.43	16.58
25130	37.16	37.83	38.10	35.60	35.78	36.60	25100	25130	15.96	16.07	16.26
25930	38.21	39.12	40.07	32.55	33.00	33.65	25900	25930	14.71	14.71	14.93
26830	38.69	39.18	39.43	28.77	29.12	29.55	26800	26830	13.83	13.90	14.04
27630	37.10	38.27	39.53	27.28	27.54	27.74	27600	27630	13.30	13.38	13.50
28430	35.98	37.13	38.96	26.15	26.24	26.25	28400	28430	13.41	13.50	13.64
29230	34.43	35.54	37.62	26.17	26.18	25.94	29200	29230	14.10	14.19	14.43
30030	31.94	32.56	34.93	26.43	26.18	25.44	30000	30030	14.92	15.02	15.31
30930	32.15	33.02	35.79	26.46	26.19	25.17	30900	30930	15.85	15.98	16.29
31730	32.31	33.56	36.68	26.70	26.07	24.94	31700	31730	18.06	18.24	18.56
32530	31.99	33.24	36.33	28.81	28.09	26.59	32500	32530	22.49	22.64	23.00
33330	30.46	31.19	34.45	30.17	29.70	28.60	33300	33330	26.15	26.29	26.72
34130	27.14	27.97	30.36	29.36	29.15	28.80	34100	34130	31.55	31.73	32.13
34930	27.88	28.76	31.45	27.30	26.98	26.29	34900	34930	36.40	36.82	37.79
35830	27.64	28.45	30.95	27.97	27.76	27.04	35800	35830	49.90	52.17	55.13
36630	27.62	28.58	30.73	29.79	29.77	29.45	36600	36630	42.40	43.50	44.50
37430	27.92	28.60	30.85	26.73	26.69	26.56	37400	37430	37.92	38.47	38.72
38230	28.69	29.16	30.76	26.38	26.32	26.40	38200	38230	35.80	36.47	36.79
39030	28.39	28.96	30.75	27.65	27.60	28.23	39000	39030	37.44	38.27	38.72
39930	29.05	29.47	31.75	28.89	28.75	29.29	39900	39930	38.65	39.52	40.69



P.O. Box 350166, Brooklyn, New York 11235-0003 • (718) 934-4500 • Fax (718) 332-4661 For detailed performance specs & shopping online see Mini-Circuits web site
 The Design Engineers Search Engine Provides ACTUAL Data Instantly From MINI-CIRCUITS At: www.minicircuits.com



IF/RF MICROWAVE COMPONENTS

Wideband Double Balanced Mixer

MDB-44H+

Typical Performance Data

RF (IN) (MHz)	LO (MHz)	RF VSWR (:1)			LO (MHz)	LO VSWR (:1)			IF (OUT) (MHz)	IF VSWR @ LO=20000MHz (:1)		
		@LO (dBm)				@LO (dBm)				@LO (dBm)		
		+14	+15	+18		+14	+15	+18		+14	+15	+18
8000	8030	12.22	12.15	11.99	8030	8.32	7.07	5.38	10	1.09	1.09	1.15
8300	8330	12.10	12.04	11.91	8330	6.41	5.69	4.89	100	1.05	1.08	1.13
8600	8630	12.30	12.22	12.06	8630	5.59	5.21	4.81	600	1.10	1.10	1.13
8900	8930	11.40	11.33	11.17	8930	4.73	4.51	4.42	1100	1.18	1.17	1.17
9200	9230	10.61	10.53	10.39	9230	4.21	4.12	4.21	1600	1.30	1.28	1.26
9500	9530	9.41	9.36	9.26	9530	3.76	3.75	4.00	2100	1.33	1.31	1.28
9800	9830	7.98	7.93	7.85	9830	3.36	3.44	3.86	2600	1.73	1.69	1.62
10100	10130	6.73	6.68	6.59	10130	3.23	3.32	3.74	3100	1.55	1.52	1.48
10450	10480	5.39	5.37	5.35	10480	2.76	2.93	3.50	3600	1.59	1.56	1.50
10750	10780	4.33	4.31	4.32	10780	2.63	2.79	3.33	4100	1.72	1.69	1.62
11050	11080	3.46	3.47	3.52	11080	2.34	2.50	3.04	4600	2.01	1.97	1.90
11350	11380	2.69	2.71	2.90	11380	2.16	2.34	2.88	5100	2.17	2.14	2.07
11650	11680	2.18	2.20	2.26	11680	2.08	2.27	2.83	5600	2.50	2.47	2.39
11950	11980	1.81	1.84	1.92	11980	2.00	2.19	2.71	6100	2.63	2.60	2.52
12250	12280	1.65	1.70	1.79	12280	1.86	2.02	2.49	6600	3.06	3.01	2.90
12550	12580	1.75	1.78	1.84	12580	1.70	1.85	2.28	8000	4.11	4.05	3.90
12900	12930	1.74	1.76	1.81	12930	1.62	1.73	2.09	8500	4.48	4.41	4.28
13200	13230	1.86	1.88	1.91	13230	1.53	1.64	1.99	9000	3.99	3.94	3.85
13500	13530	1.86	1.87	1.88	13530	1.57	1.66	1.98	9500	3.27	3.24	3.18
13800	13830	1.97	1.98	1.97	13830	1.59	1.68	2.01	10000	2.71	2.68	2.62
14100	14130	2.11	2.10	2.08	14130	1.66	1.74	2.04	10450	2.34	2.30	2.23
14400	14430	2.22	2.21	2.18	14430	1.71	1.79	2.05	10950	2.17	2.12	2.03
14700	14730	2.35	2.33	2.28	14730	1.76	1.83	2.09	11450	2.24	2.19	2.09
15000	15030	2.57	2.55	2.48	15030	1.89	1.94	2.15	11950	2.30	2.27	2.22
15350	15380	2.81	2.77	2.65	15380	2.06	2.09	2.26	12450	2.67	2.66	2.64
15650	15680	3.23	3.18	3.02	15680	2.23	2.24	2.38	12950	3.24	3.24	3.24
15950	15980	3.47	3.41	3.23	15980	2.36	2.36	2.46	13450	3.23	3.25	3.30
16250	16280	3.29	3.23	3.08	16280	2.47	2.44	2.49	13950	3.97	4.03	4.15
16550	16580	3.18	3.12	2.95	16580	2.58	2.53	2.54	14450	5.77	5.84	6.00
16850	16880	3.13	3.07	2.93	16880	2.69	2.61	2.57	14950	5.57	5.62	5.72
17150	17180	2.80	2.75	2.67	17180	2.75	2.66	2.60	15450	5.43	5.49	5.63
17450	17480	2.45	2.41	2.34	17480	2.81	2.69	2.59	15950	10.39	10.55	10.88
17800	17830	2.35	2.31	2.26	17830	2.83	2.65	2.50	16450	7.39	7.44	7.54
18100	18130	2.29	2.23	2.18	18130	3.00	2.76	2.57	16950	8.56	8.63	8.74
18400	18430	2.29	2.22	2.12	18430	3.05	2.78	2.45	17450	12.67	12.81	13.03
18700	18730	2.27	2.20	2.10	18730	3.21	2.88	2.51	17950	9.91	10.05	10.11
19000	19030	2.08	2.03	2.00	19030	3.10	2.80	2.68	18450	10.78	10.82	10.87
19300	19330	1.88	1.83	1.77	19330	3.03	2.73	2.45	18950	43.79	43.95	44.58
19600	19630	1.68	1.64	1.62	19630	2.95	2.67	2.55	19450	12.11	12.09	12.12
19950	19980	1.47	1.44	1.42	19980	2.93	2.62	2.47	19950	13.49	13.53	13.52



P.O. Box 350166, Brooklyn, New York 11235-0003 (718) 934-4500 • Fax (718) 332-4661 For detailed performance specs & shopping online see Mini-Circuits web site
 The Design Engineers Search Engine Provides ACTUAL Data Instantly From MINI-CIRCUITS At: www.minicircuits.com



IF/RF MICROWAVE COMPONENTS

REV. OR
 MDB-44H+
 1/10/2018
 Page 5 of 6

Harmonics Tables

RF HARMONICS ORDER

	(-dBm)	(-dBc)										
0	---	---	13.47	22.65	---	---	---	---	---	---	---	---
1	---	9.82	---	35.55	---	---	---	---	---	---	---	---
2	69.95	47.00	67.58	56.46	52.78	---	---	---	---	---	---	---
3	---	---	59.96	71.93	54.77	72.68	---	---	---	---	---	---
4	---	---	---	80.60	94.71	88.92	85.32	---	---	---	---	---
5	---	---	---	---	83.90	95.83	91.59	86.59	---	---	---	---
6	---	---	---	---	---	82.38	95.75	96.48	80.32	---	---	---
7	---	---	---	---	---	---	81.78	98.55	91.06	83.17	---	---
8	---	---	---	---	---	---	---	86.98	96.39	95.53	82.17	---
9	---	---	---	---	---	---	---	---	87.92	98.18	92.11	81.65
10	---	---	---	---	---	---	---	---	---	92.98	101.10	93.71
	RF CAL	0	1	2	3	4	5	6	7	8	9	10

LO HARMONICS ORDER

Test conditions: RF IN: 23000 MHz; 0 dBm.
 LO IN: 25000 MHz; +15 dBm
 IF OUT: 2000 MHz; -8.11 dBm

RF HARMONICS ORDER

	(-dBm)	(-dBc)										
0	---	---	23.51	31.28	---	---	---	---	---	---	---	---
1	---	9.41	---	38.47	---	---	---	---	---	---	---	---
2	61.17	36.49	57.35	50.69	45.32	---	---	---	---	---	---	---
3	---	---	35.51	48.40	33.25	51.58	---	---	---	---	---	---
4	---	---	---	59.68	56.54	57.08	65.03	---	---	---	---	---
5	---	---	---	---	64.38	64.83	53.19	84.01	---	---	---	---
6	---	---	---	---	---	80.49	63.48	71.90	74.62	---	---	---
7	---	---	---	---	---	---	82.37	70.61	56.58	82.83	---	---
8	---	---	---	---	---	---	---	85.58	67.26	77.86	71.69	---
9	---	---	---	---	---	---	---	---	82.60	79.63	78.17	80.73
10	---	---	---	---	---	---	---	---	---	91.13	69.87	91.24
	RF CAL	0	1	2	3	4	5	6	7	8	9	10

LO HARMONICS ORDER

Test conditions: RF IN: 23000 MHz; +10 dBm.
 LO IN: 25000 MHz; +15 dBm
 IF OUT: 2000 MHz; 1.69 dBm

- Notes:
1. All Harmonics are in (dBc) relative to IF OUTPUT
 2. + entry denotes harmonics are in (dBc) above IF OUTPUT
 3. RF Cal represents the Harmonics level of the RF Input Signal to the mixer



Typical Performance Curves

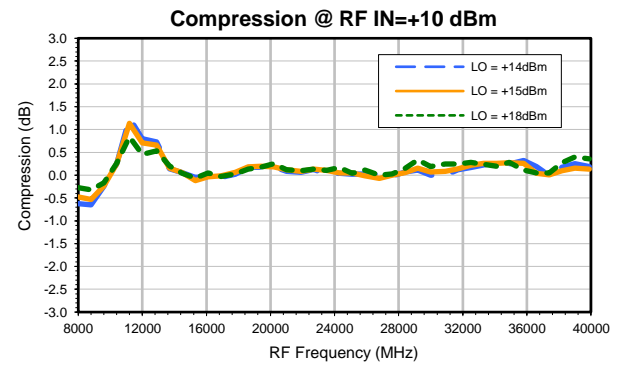
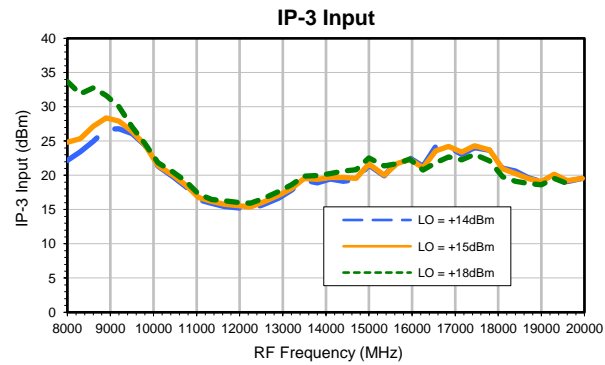
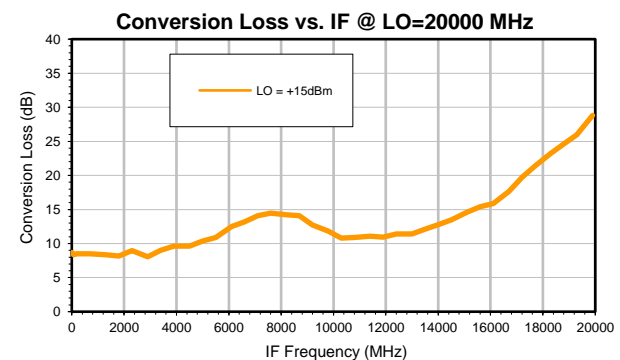
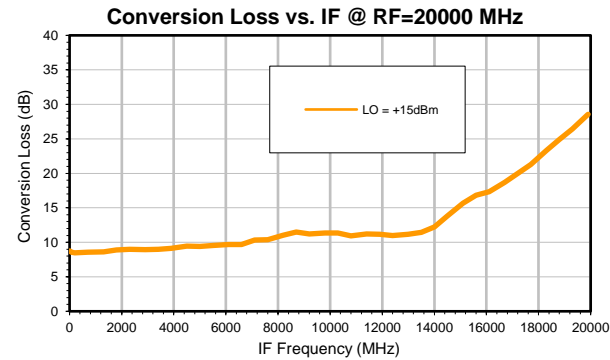
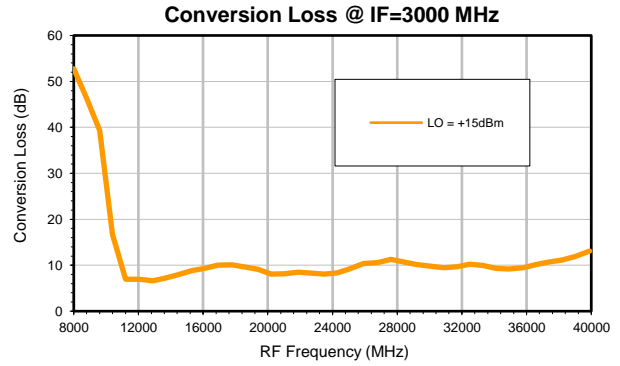
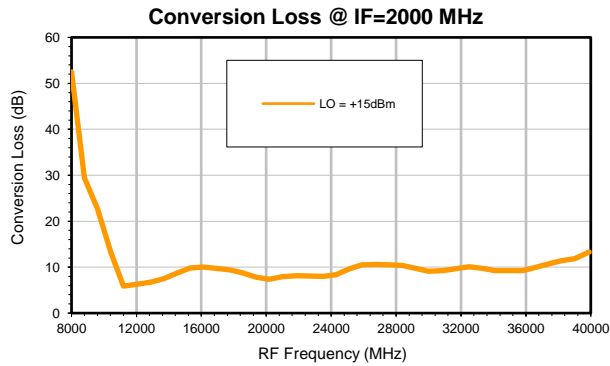
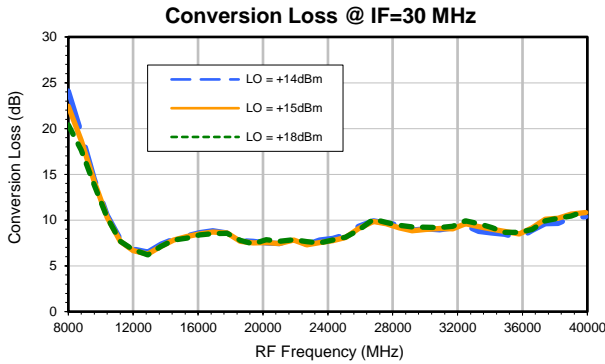

P.O. Box 350166, Brooklyn, New York 11235-0003 • (718) 934-4500 • Fax (718) 332-4661 For detailed performance specs & shopping online see Mini-Circuits web site
The Design Engineers Search Engine Provides ACTUAL Data Instantly From MINI-CIRCUITS At: www.minicircuits.com



IF/RF MICROWAVE COMPONENTS

Typical Performance Curves

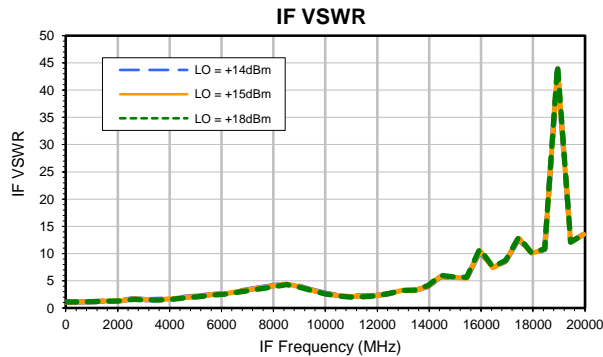
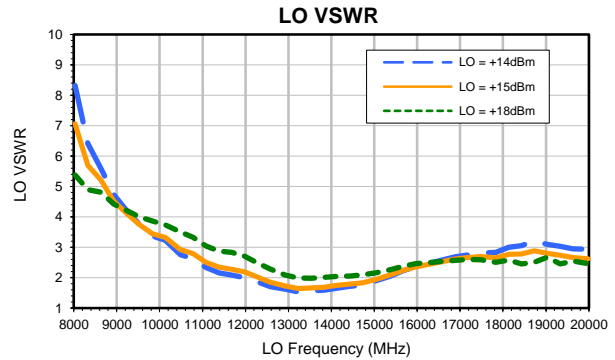
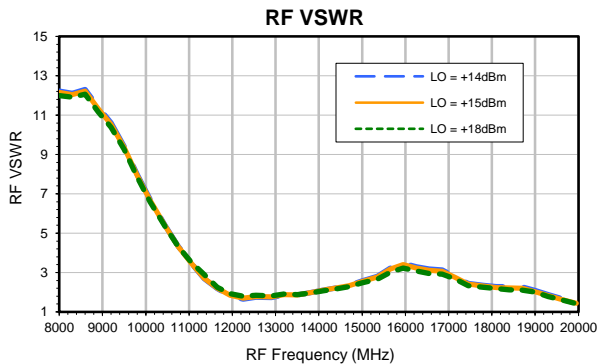
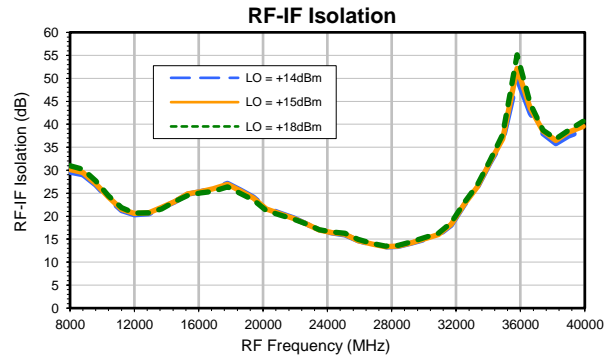
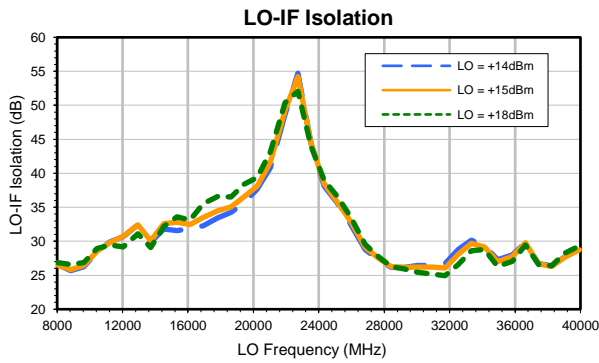
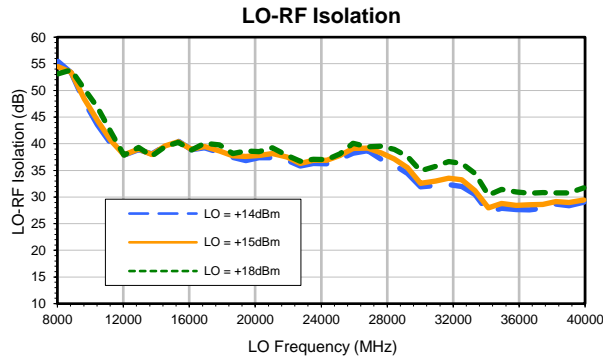

Harmonics Tables

RF HARMONICS ORDER

	(-dBm)	(-dBc)										
0	---	---	13.47	22.65	---	---	---	---	---	---	---	---
1	---	9.82	---	35.55	---	---	---	---	---	---	---	---
2	69.95	47.00	67.58	56.46	52.78	---	---	---	---	---	---	---
3	---	---	59.96	71.93	54.77	72.68	---	---	---	---	---	---
4	---	---	---	80.60	94.71	88.92	85.32	---	---	---	---	---
5	---	---	---	---	83.90	95.83	91.59	86.59	---	---	---	---
6	---	---	---	---	---	82.38	95.75	96.48	80.32	---	---	---
7	---	---	---	---	---	---	81.78	98.55	91.06	83.17	---	---
8	---	---	---	---	---	---	---	86.98	96.39	95.53	82.17	---
9	---	---	---	---	---	---	---	---	87.92	98.18	92.11	81.65
10	---	---	---	---	---	---	---	---	---	92.98	101.10	93.71
	RF CAL	0	1	2	3	4	5	6	7	8	9	10

LO HARMONICS ORDER

Test conditions: RF IN: 23000 MHz; 0 dBm.
 LO IN: 25000 MHz; +15 dBm
 IF OUT: 2000 MHz; -8.11 dBm

RF HARMONICS ORDER

	(-dBm)	(-dBc)										
0	---	---	23.51	31.28	---	---	---	---	---	---	---	---
1	---	9.41	---	38.47	---	---	---	---	---	---	---	---
2	61.17	36.49	57.35	50.69	45.32	---	---	---	---	---	---	---
3	---	---	35.51	48.40	33.25	51.58	---	---	---	---	---	---
4	---	---	---	59.68	56.54	57.08	65.03	---	---	---	---	---
5	---	---	---	---	64.38	64.83	53.19	84.01	---	---	---	---
6	---	---	---	---	---	80.49	63.48	71.90	74.62	---	---	---
7	---	---	---	---	---	---	82.37	70.61	56.58	82.83	---	---
8	---	---	---	---	---	---	---	85.58	67.26	77.86	71.69	---
9	---	---	---	---	---	---	---	---	82.60	79.63	78.17	80.73
10	---	---	---	---	---	---	---	---	---	91.13	69.87	91.24
	RF CAL	0	1	2	3	4	5	6	7	8	9	10

LO HARMONICS ORDER

Test conditions: RF IN: 23000 MHz; +10 dBm.
 LO IN: 25000 MHz; +15 dBm
 IF OUT: 2000 MHz; 1.69 dBm

- Notes:
1. All Harmonics are in (dBc) relative to IF OUTPUT
 2. + entry denotes harmonics are in (dBc) above IF OUTPUT
 3. RF Cal represents the Harmonics level of the RF Input Signal to the mixer



Outline Dimensions

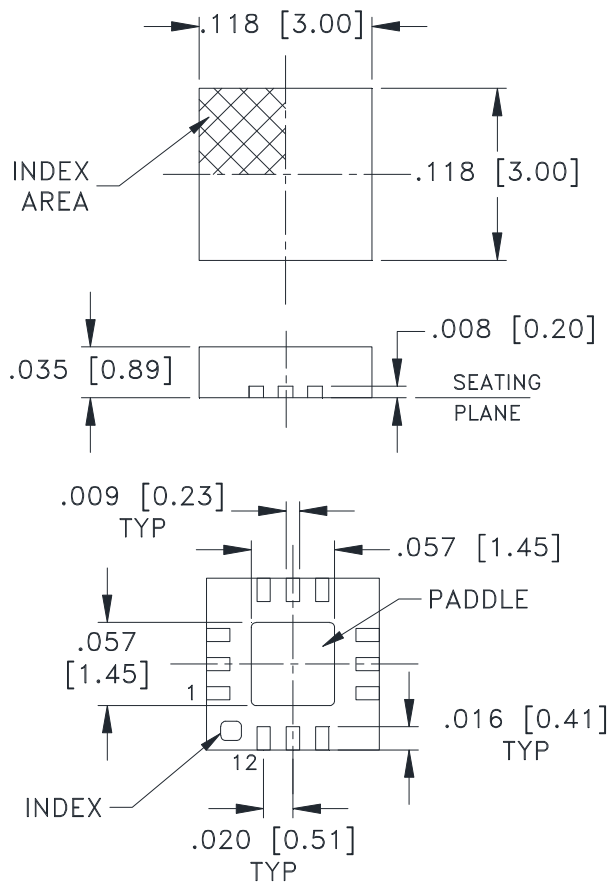

PCB Land Pattern

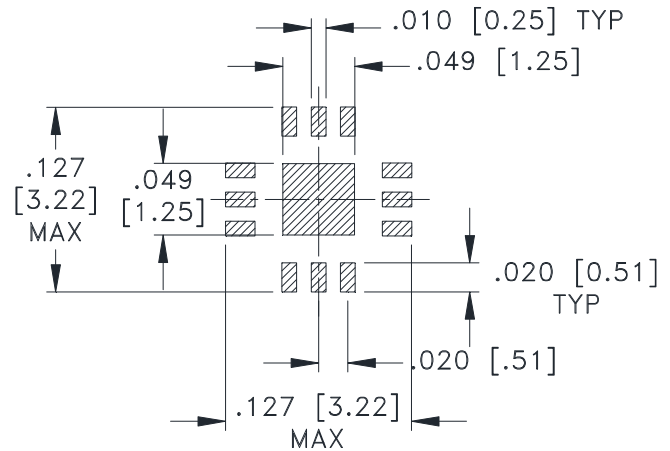

SUGGESTED LAYOUT,
TOLERANCE TO BE WITHIN $\pm .002$

Weight: .02 Grams

Dimensions are in inches (mm). Tolerances: 2Pl. $\pm .01$; 3 Pl. $\pm .004$

Notes:

1. Case material: Plastic.
2. Termination finish:
 - For RoHS Case Styles: Tin-Silver alloy plate over Nickel barrier or Matte-Tin. All models, (+) suffix. See Data sheet.
 - For RoHS-5 Case Styles: Tin-Lead plate. All models, no (+) suffix.

Mini-Circuits®

Distribution Centers NORTH AMERICA 800-654-7949 • 417-335-5935 • Fax 417-335-5945 • EUROPE 44-1252-832600 • Fax 44-1252-837010

Mini-Circuits ISO 9001 & ISO 14001 Certified

INTERNET <http://www.minicircuits.com>

P.O. Box 350166, Brooklyn, New York 11235-0003 (718) 934-4500 Fax (718) 332-4661

Tape & Reel Packaging TR-F66

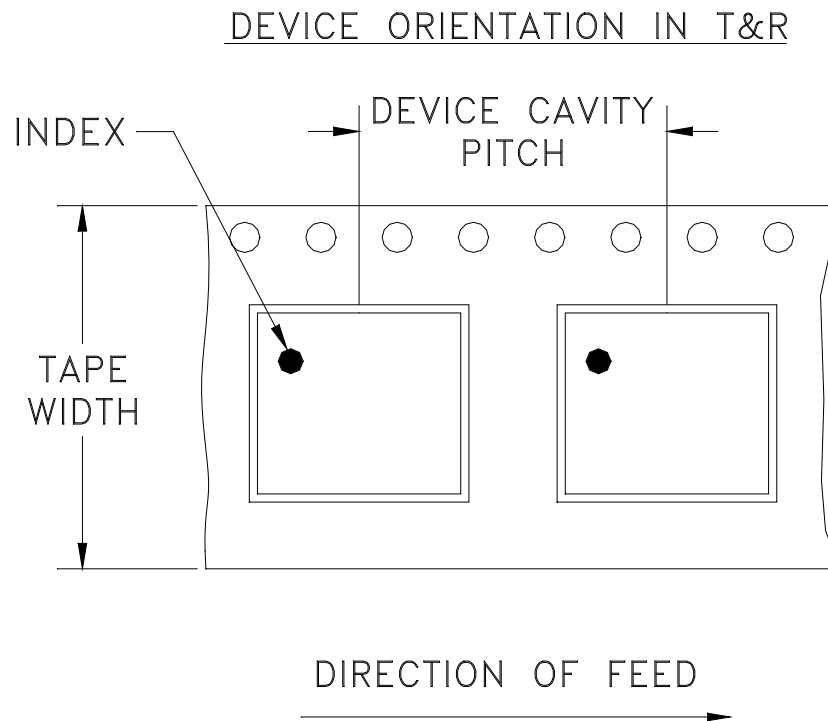

Tape Width, mm	Device Cavity Pitch, mm	Reel Size, inches	Devices per Reel see note	
8	4	7	Small quantity standard	20
				50
				100
				200
				500
		7	Standard	1000, 2000, 3000

Note: Please consult individual model data sheet to determine device per reel availability.

Mini-Circuits carrier tape materials provide protection from ESD (Electro-Static Discharge) during handling and transportation. Tapes are static dissipative and comply with industry standards EIA-481/EIA-541.

Go to: www.minicircuits.com/pages/pdfs/tape.pdf

Mini-Circuits®

INTERNET <http://www.minicircuits.com>

P.O. Box 350166, Brooklyn, New York 11235-0003 (718) 934-4500 Fax (718) 332-4661

Distribution Centers NORTH AMERICA 800-654-7949 • 417-335-5935 • Fax 417-335-5945 • EUROPE 44-1252-832600 • Fax 44-1252-837010

Mini-Circuits ISO 9001 & ISO 14001 Certified

THIRD ANGLE PROJECTION

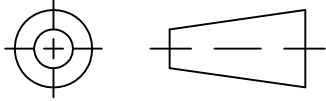

REVISIONS

REV OR	ECN No.	DESCRIPTION	DATE	DR	AUTH
	M165191	NEW RELEASE	12/13/17	ITG	JX

**SUGGESTED MOUNTING CONFIGURATION
FOR DQ1225 CASE STYLE, "12MX01" PIN CODE**

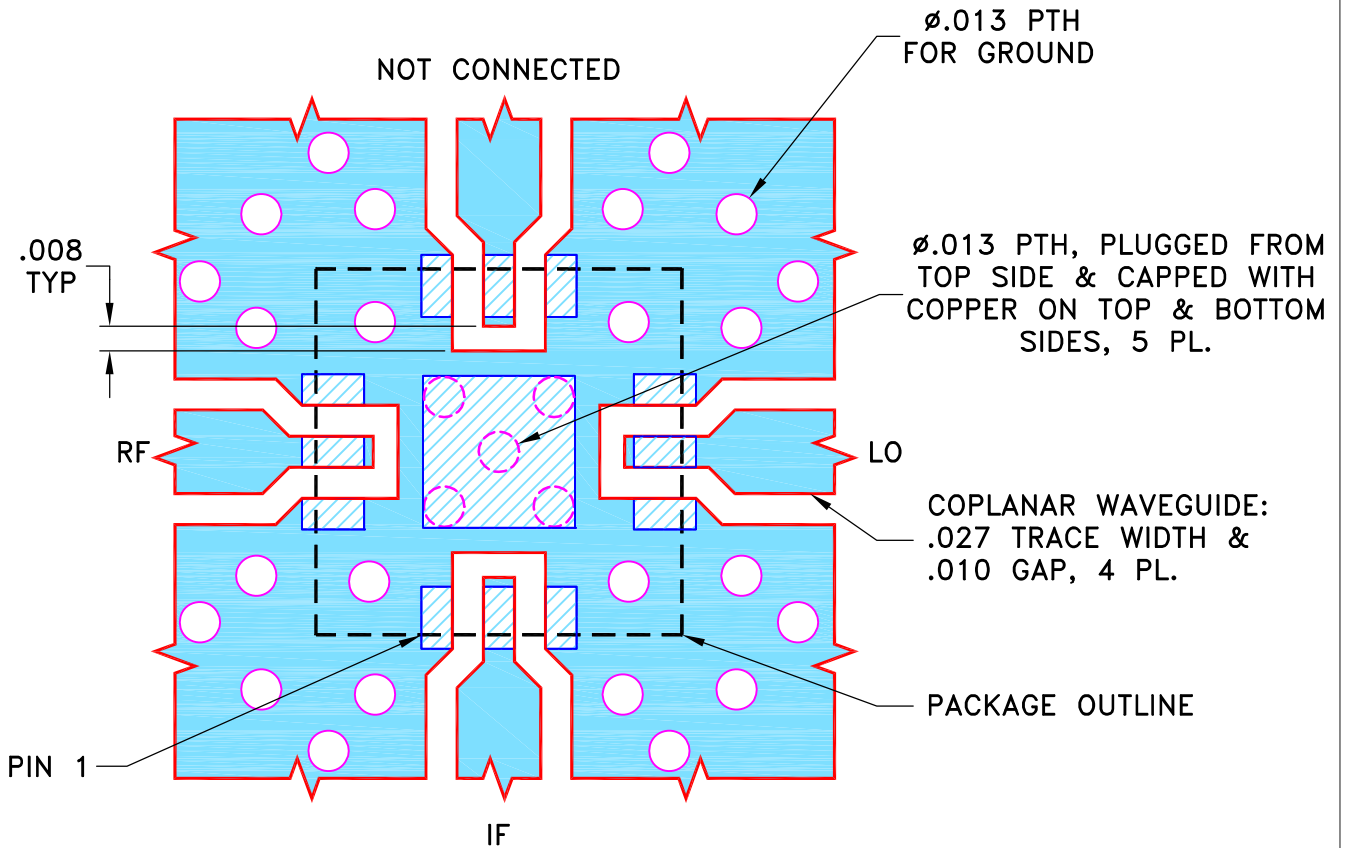

NOTES:

- TRACE WIDTH PARAMETERS ARE SHOWN FOR TACONIC TLY-5 WITH DIELECTRIC THICKNESS .010"±.001". COPPER: 1/2 OZ. EACH SIDE. FOR OTHER MATERIALS TRACE WIDTH AND GAP MAY NEED TO BE MODIFIED.
- BOTTOM SIDE OF THE PCB IS CONTINUOUS GROUND PLANE.



DENOTES PCB COPPER LAYOUT WITH SMOBC (SOLDER MASK OVER BARE COPPER).

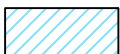

DENOTES COPPER LAND PATTERN FREE OF SOLDER MASK.

UNLESS OTHERWISE SPECIFIED	INITIALS		DATE
DIMENSIONS ARE IN INCHES TOLERANCES ON: 2 PL DECIMALS ± 3 PL DECIMALS ± .005 ANGLES ± FRACTIONS ±	DRAWN	ITG	12/11/17
	CHECKED	GF	12/13/17
	APPROVED	JX	12/13/17



Mini-Circuits®

13 Neptune Avenue
Brooklyn NY 11235

PL, 12MX01, DQ1225, TB-973+

SIZE	CODE IDENT	DRAWING NO:	REV:
A	15542	98-PL-540	OR
FILE:	98PL540	SCALE:	16:1
		SHEET:	1 OF 1

THIS DOCUMENT AND ITS CONTENTS ARE THE PROPERTY OF MINI-CIRCUITS. EXCEPT FOR USE EXPRESSLY GRANTED, IN WRITING, TO ITS VENDORS, VENDEE AND THE UNITED STATES GOVERNMENT, MINI-CIRCUITS RESERVES ALL PROPRIETARY DESIGN, USE, MANUFACTURING AND REPRODUCTION RIGHTS THERETO. THESE CONTENTS SHALL NOT BE USED, DUPLICATED OR DISCLOSED TO ANY OUTSIDE PARTY, IN WHOLE OR IN PART, WITHOUT WRITTEN PERMISSION OF MINI-CIRCUITS.

Evaluation Board and Circuit

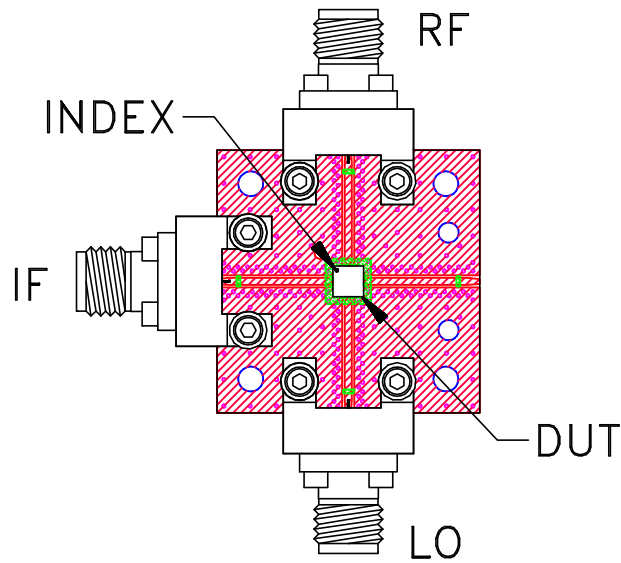

TB-973-MDB44HC+

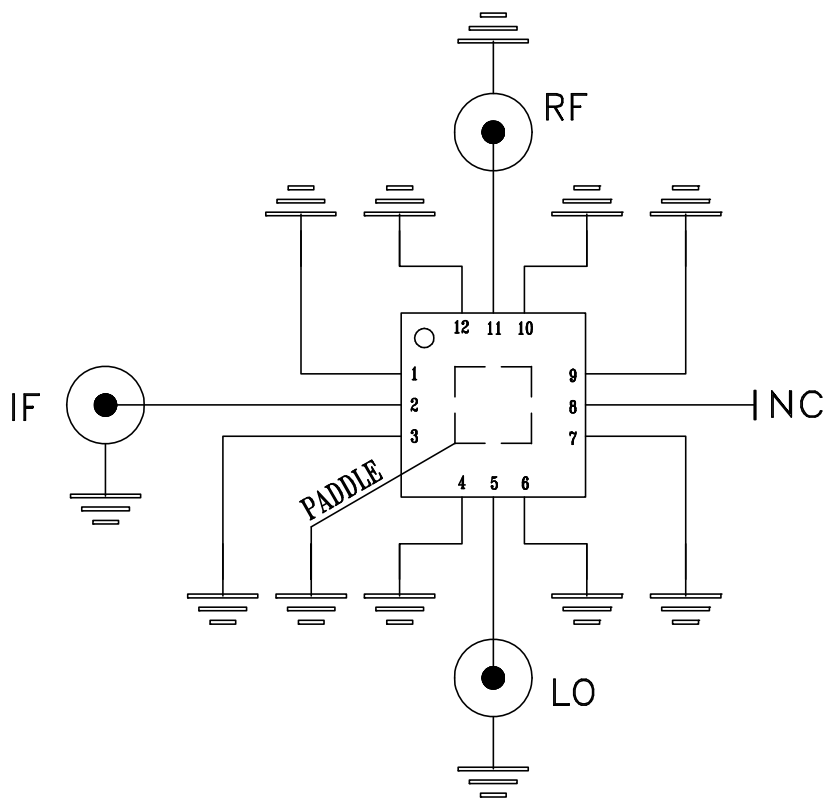

Schematic Diagram

Notes:

1. 50 Ohm 2.92mm Female end launch connectors.
2. PCB Material: TLY-5 or equivalent,
Dielectric Constant=2.2, Thickness=.010 inch.

 **Mini-Circuits®**

All Mini-Circuits products are manufactured under exacting quality assurance and control standards, and are capable of meeting published specifications after being subjected to any or all of the following physical and environmental test.

Specification	Test/Inspection Condition	Reference/Spec
Operating Temperature	-40° to 85°C or -45° to 85°C Ambient Environment	Individual Model Data Sheet
Storage Temperature	-55° to 100° C or -65° to 150° Ambient Environment	Individual Model Data Sheet
Thermal Shock	-55° to 100°C, 100 cycles	MIL-STD-202, Method 107, Condition A-3, except +100°C
Mechanical Shock	1.5Kg, 0.5 ms, 5 shock pulses, Y1 direction only	MIL-STD-883, Method 2002, Condition B, except Y1 direction only
Vibration (Variable Frequency)	50g peak	MIL-STD-883, Method 2007, Condition B
Autoclave	15 psig, 100% RH, 121°C, 96 hours	JESD22-A102, Condition C
HAST	130°C, 85% RH, 96 hours	JESD22-A110
Solderability	10X Magnification	J-STD-002, Para 4.2.5, Test S, 95% Coverage
Solder Reflow Heat	Sn-Pb Eutetic Process: 240°C peak Pb-Free Process: 260°C peak	J-STD-020, Table 4-1, 4-2 and 5-2; Figure 5-1
Moisture Sensitivity: Level 1	Bake at 125°C for 24 hours Soak at 85°C/85% RH for 168 hours, Reflow 3 cycles at 260°C peak	J-STD-020
Marking Resistance to Solvents	Isopropyl alcohol + mineral spirits at 25°C; terpene defluxer at 25°C; distilled water + proylene glycol monomethyl ether +	MIL-STD-202, Method 215



All Mini-Circuits products are manufactured under exacting quality assurance and control standards, and are capable of meeting published specifications after being subjected to any or all of the following physical and environmental test.

Specification	Test/Inspection Condition	Reference/Spec
	monoethanolamine at 63°C to 70°C	