

MMIC Surface Mount Wideband Double Balanced Mixer-Amplifier

MDA4-752H+

Level 0 (LO Power 0dBm) 2200-7500 MHz

The Big Deal

- High L-I Isolation, 61 dB
- Low LO Power, 0 dBm
- Small Size, 4 x 4 x 1mm



CASE STYLE: DG1847

Product Overview

MDA4-752H+ is a multi-chip module incorporating a mixer (InGaP HBT), LO amplifier (InGaP HBT) and IF amplifier (E-PHEMT) dice in as single package. It has flat conversion gain over a broad frequency range and with high IP3. In addition, the MDA4-752H+ has good input and output return loss over a broad frequency range without the need for external matching components. It is packaged in a tiny 4x4 mm MCLP package.

Key Features

Feature	Advantages
Wide Bandwidth 2.2 to 7.5 GHz	Useful in wideband systems or in several narrowband systems, reducing inventory.
Wide IF Bandwidth 0.03 to 1.6 GHz	Usable in first (high IF-860 MHz) and second (low IF-70 MHz) down converter applications.
Conversion Gain, 4 to 9 dB	Incorporate low noise IF amplifier to enable positive conversion gain, minimizing the need for external amplifier circuits.
Low LO Power operation	Through the integration of a LO amplifier, the MDA4-752H+ can operate down to -3 dBm making this module very versatile as a receiver building block.
High LO-IF and RF-IF isolation 50 – 65 dB over 4 to 7.5 GHz	When used in suggested application circuit, provides outstanding isolation, minimizing the need for further filtering.
4 mm x 4 mm, 24 lead MCLP Package	Integrates Mixer, LO Amplifier and IF Amplifier into one package reducing PCB size. MCLP package has low inductance, repeatable transitions, and excellent thermal contact to PCB



MMIC Surface Mount Wideband Double Balanced Mixer-Amplifier

MDA4-752H+

Level 0 (LO Power 0dBm) 2200-7500 MHz

Product Features

- Wide bandwidth 2200 to 7500 MHz
- High L-I Isolation, 61 dB typ. at 4 GHz
- Operates with low LO power, 0 dBm
- Small Size 4 mm x 4mm x 1mm
- Aqueous washable

Typical Applications

- Satellite down converters
- Defense radar & communication
- VSAT
- Aeronautical



CASE STYLE: DG1847

+RoHS Compliant

The +Suffix identifies RoHS Compliance. See our web site for RoHS Compliance methodologies and qualifications

General Description

MDA4-752H+ is a multi-chip module incorporating a mixer (InGap HBT), LO amplifier (InGap HBT) and IF amplifier (E-PHEMT) dice in as single package. It has flat conversion gain over a broad frequency range and with high IP3. In addition, the MDA4-752H+ has good input and output return loss over a broad frequency range without the need for external matching components. It is packaged in a tiny 4x4 mm MCLP package.

simplified schematic and bonding pad description

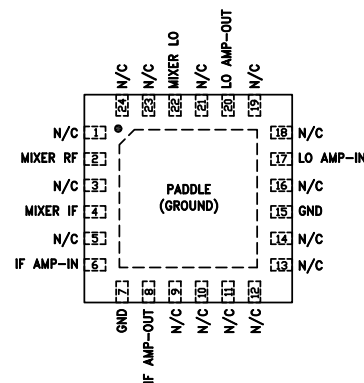
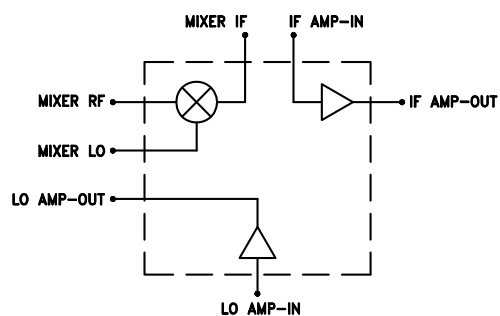

Function	Pad Number	Description
Mixer-RF	2	RF input to mixer
Mixer-LO	22	LO input to mixer
Mixer-IF	4	IF output from mixer
LO AMP-IN	17	LO Amplifier input
LO AMP-OUT	20	LO Amplifier output & DC-IN
IF AMP-IN	6	IF Amplifier input
IF AMP-OUT	8	IF Amplifier output & DC-IN
GND	7, Paddle	Connect to Ground
NC	1, 3,5,9-16,18,19,21,23,24	No connection, not used, ground externally

Electrical Specifications^{1,2} at 25°C, unless noted

Parameter	Condition (GHz)	Min.	Typ.	Max.	Units
RF Frequency Range		2.2		7.5	GHz
LO Frequency Range		2.2		7.5	GHz
IF Frequency Range		0.03		1.6	GHz
LO Power			0		dBm
Conversion Gain (at IF=30 MHz)	2.2	—	7.6	—	dB
	3.0	—	9.7	—	
	4.0	8.1	9.1	10.4	
	5.0	—	7.6	—	
	6.0	—	7.3	—	
	7.5	—	4.2	—	
LO-RF Isolation	2.2	—	23	—	dB
	3.0	—	20	—	
	4.0	24	31	—	
	5.0	—	25	—	
	6.0	—	21	—	
	7.5	—	23	—	
LO-IF Isolation	2.2	—	19	—	dB
	3.0	—	35	—	
	4.0	53	61	—	
	5.0	—	64	—	
	6.0	—	59	—	
	7.5	—	60	—	
RF-IF Isolation	2.2		7		dB
	3.0		25		
	4.0		51		
	5.0		65		
	6.0		57		
	7.5		54		
Input at 1dB Compression	2-2 - 7.5		9		dBm
Input IP3	2.2		16		dBm
	3.0		15		
	4.0		15		
	5.0		16		
	6.0		16		
	7.5		19		
Noise Figure	2.3		8.6		dB
	3.0		9.6		
	4.0		9.9		
Thermal Resistance (junction-to-ground lead)			39		°C/W
DC Voltage			5		V
DC Current			141	169	mA

⁽¹⁾ Measured on Mini-Circuits Characterization test board TB-771+ as down converter. See Characterization Test Circuit Figure 1

⁽²⁾ Thermal Resistance= (Temperature rise of the diode hot spot above ground lead ÷ Total power dissipation)

Absolute Maximum Ratings³

Parameter	Ratings	
Operating Temperature	-40°C to 85°C	
Storage Temperature	-65°C to 150°C	
Mixer	RF-IN	21 dBm
	LO-IN	21 dBm
	IF Current	30 mA
IF Amplifier - IN	+23 dBm (5 minutes max.) +17 dBm (continuous)	
LO Amplifier - IN	+24 dBm	
Power Dissipation	LO Amplifier	0.725W
	IF Amplifier	0.47W
DC voltage	5.5V	

³ Permanent damage may occur if any of these limits are exceeded.
Electrical maximum ratings are not intended for continuous normal operation.



Characterization and Application Test Circuit

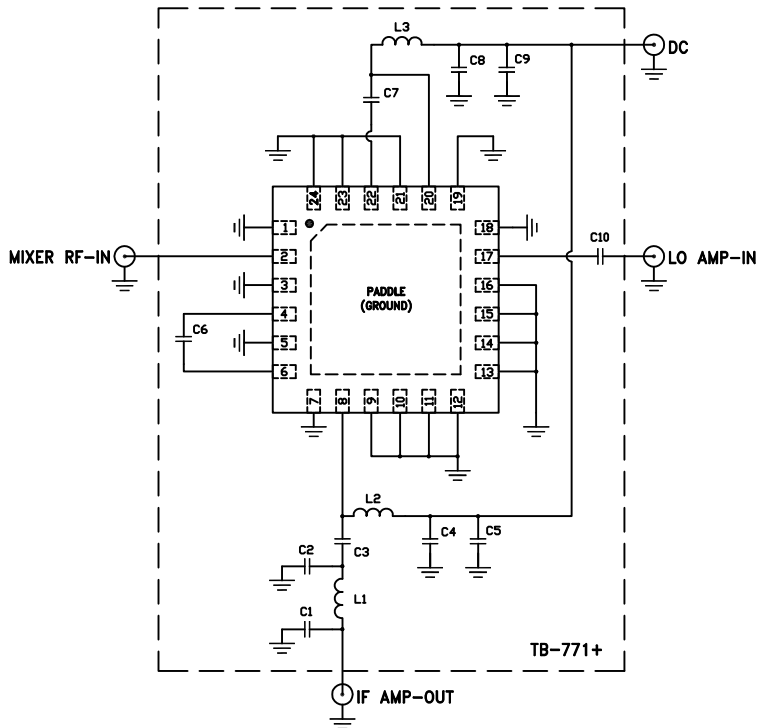

Component	Size	Value	Units
DUT		MDA4-752H+	—
L1	0402	4.7	nH
L2	0603	390	nH
L3	0402	36	nH
C1,C2	0402	3	pF
C3, C6	0402	.01	μF
C4,C7,C8,C10	0402	100	pF
C5,C9	0402	0.1	μF

Figure 1. Block Diagram of Test Circuit used for characterization. (DUT soldered on Mini-Circuits Characterization test board TB-771+). Conversion Loss, Isolations; L-R, L-I & R-I are measured using R&S ZVA 24 microwave network analyzer. Input IP3 is measured Agilent MXA N9020A spectrum Analyzer and PSG E8257D Signal Generators. NF is measured using Agilent's N8975A NF Analyzer

Conditions (Down Converter):

1. Conversion Loss, Isolations (L-R, L-I & R-I): RF= -10 dBm, LO=0 dBm, IF=30 MHz
2. Output IP3 (OIP3): Two tones, spaced 1 MHz apart, -10 dBm/tone at output.
3. Noise Figure: LO=0 dBm

Product Marking



Additional Detailed Technical Information	
<i>additional information is available on our dash board. To access this information click here</i>	
Performance Data	Data Table
	Swept Graphs
	S-Parameter (S1P Files) Data Set (.zip file)
Case Style	DG1847 Plastic package, exposed paddle, lead finish: matte-tin
Tape & Reel Standard quantities available on reel	F68 7" reels with 10,20, 50, 100, 200, 500 or 1K devices
Suggested Layout for PCB Design	PL-433
Evaluation Board	TB-771+
Environmental Ratings	ENV08T1

ESD Rating

Human Body Model (HBM): Class 1A (250 to 500V) in accordance with ANSI/ESD STM 5.1 - 2001

Machine Model (MM): Class M1 (Pass 25V) in accordance with ANSI/ESD STM5.2-1999

MSL Rating

Moisture Sensitivity: MSL1 in accordance with IPC/JEDEC J-STD-020D

MSL Test Flow Chart

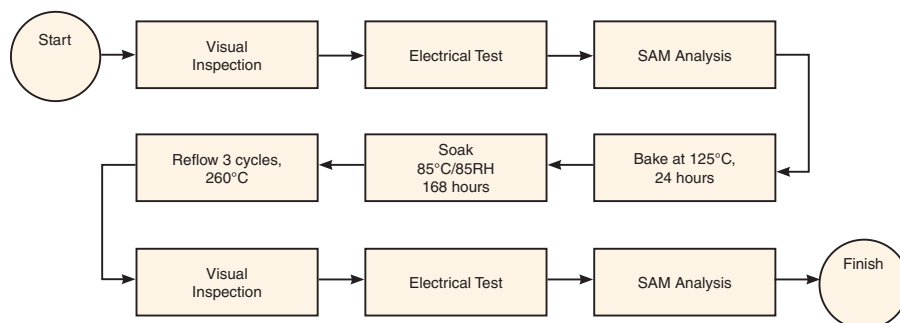

Additional Notes

- A. Performance and quality attributes and conditions not expressly stated in this specification document are intended to be excluded and do not form a part of this specification document.
- B. Electrical specifications and performance data contained in this specification document are based on Mini-Circuit's applicable established test performance criteria and measurement instructions.
- C. The parts covered by this specification document are subject to Mini-Circuits standard limited warranty and terms and conditions (collectively, "Standard Terms"); Purchasers of this part are entitled to the rights and benefits contained therein. For a full statement of the Standard Terms and the exclusive rights and remedies thereunder, please visit Mini-Circuits' website at www.minicircuits.com/MCLStore/terms.jsp

Wideband Double Balanced Mixer-Amplifier

MDA4-752H+

Typical Performance Data

RF (IN) (MHz)	LO (MHz)	CONVERSION GAIN IF FIXED @IF(OUT)=30MHz (dB)		
		@LO (dBm)		
		-3	0	+3
1000.1	1030.1	2.85	3.62	3.86
1200.1	1230.1	3.52	3.84	4.16
1420.1	1450.1	1.41	2.60	3.19
1640.1	1670.1	2.70	4.50	5.03
1860.1	1890.1	5.18	6.06	6.44
2080.1	2110.1	6.59	7.30	7.53
2300.1	2330.1	8.11	8.50	8.50
2520.1	2550.1	8.98	9.19	9.14
2740.1	2770.1	9.63	9.77	9.70
2960.1	2990.1	9.90	9.98	9.90
3160.1	3190.1	10.04	10.07	9.95
3380.1	3410.1	9.93	10.10	10.03
3600.1	3630.1	9.61	9.86	9.86
3820.1	3850.1	9.53	9.83	9.81
4040.1	4070.1	8.82	9.52	9.61
4260.1	4290.1	7.80	9.12	9.26
4480.1	4510.1	6.63	8.61	8.87
4700.1	4730.1	6.12	8.33	8.64
4920.1	4950.1	5.88	8.10	8.39
5140.1	5170.1	5.81	7.94	8.19
5340.1	5370.1	6.13	7.91	8.15
5560.1	5590.1	6.37	7.80	8.11
5780.1	5810.1	6.21	7.38	7.75
6000.1	6030.1	6.87	7.79	8.06
6220.1	6250.1	6.98	8.06	8.28
6440.1	6470.1	6.36	7.83	8.13
6660.1	6690.1	5.29	7.31	7.76
6880.1	6910.1	4.03	6.85	7.62
7100.1	7130.1	3.47	6.53	7.46
7320.1	7350.1	2.97	5.87	6.84
7520.1	7550.1	1.04	4.27	5.52
7740.1	7770.1	-2.42	1.91	3.84
7960.1	7990.1	-7.38	-0.99	2.02
8180.1	8210.1	-14.28	-5.71	-0.60

RF (IN) (MHz)	LO (MHz)	IP-3 INPUT (dBm)		
		@LO (dBm)		
		-3	0	+3
1000.1	1030.1	13.36	16.41	17.32
1200.1	1230.1	16.61	22.76	21.47
1420.1	1450.1	15.71	18.05	22.21
1640.1	1670.1	11.73	18.16	21.96
1860.1	1890.1	13.76	17.37	19.93
2080.1	2110.1	11.19	15.16	17.68
2300.1	2330.1	13.36	16.88	18.65
2520.1	2550.1	14.20	16.05	17.57
2740.1	2770.1	14.79	15.90	16.99
2960.1	2990.1	14.19	15.34	16.29
3160.1	3190.1	14.23	15.05	15.90
3380.1	3410.1	13.11	14.26	14.95
3600.1	3630.1	12.52	14.46	15.35
3820.1	3850.1	14.68	16.54	17.44
4040.1	4070.1	12.45	15.07	16.11
4260.1	4290.1	11.02	14.31	15.33
4480.1	4510.1	10.68	13.91	14.88
4700.1	4730.1	11.02	15.25	15.73
4920.1	4950.1	11.33	15.48	16.35
5140.1	5170.1	11.78	16.77	16.54
5340.1	5370.1	15.03	20.49	18.62
5560.1	5590.1	15.65	19.87	19.24
5780.1	5810.1	14.07	16.60	17.77
6000.1	6030.1	14.59	16.80	18.26
6220.1	6250.1	17.28	18.91	19.87
6440.1	6470.1	19.40	19.90	20.39
6660.1	6690.1	16.84	19.37	20.32
6880.1	6910.1	13.75	18.82	18.54
7100.1	7130.1	12.88	18.95	17.74
7320.1	7350.1	13.93	18.57	17.88
7520.1	7550.1	13.18	21.89	19.40
7740.1	7770.1	9.97	17.29	26.43
7960.1	7990.1	6.67	14.29	20.24
8180.1	8210.1	3.53	9.70	20.10

RF (IN) (MHz)	LO (MHz)	COMPRESSION @RF IN=10dBm (dB)		
		@LO (dBm)		
		-3	0	+3
1000.1	1030.1	0.56	0.65	0.65
1200.1	1230.1	0.67	0.61	0.69
1420.1	1450.1	-0.50	0.07	0.37
1640.1	1670.1	0.48	1.59	1.78
1860.1	1890.1	1.98	2.35	2.37
2080.1	2110.1	2.12	2.32	2.22
2300.1	2330.1	2.41	2.22	1.95
2520.1	2550.1	2.54	2.20	1.89
2740.1	2770.1	2.68	2.39	2.11
2960.1	2990.1	2.55	2.38	2.19
3160.1	3190.1	2.50	2.35	2.17
3380.1	3410.1	2.24	2.18	2.06
3600.1	3630.1	1.71	1.75	1.70
3820.1	3850.1	1.49	1.46	1.41
4040.1	4070.1	1.16	1.26	1.23
4260.1	4290.1	0.73	1.17	1.15
4480.1	4510.1	0.09	1.01	1.03
4700.1	4730.1	-0.07	0.97	1.01
4920.1	4950.1	-0.15	0.90	0.94
5140.1	5170.1	-0.14	0.86	0.86
5340.1	5370.1	0.16	0.87	0.85
5560.1	5590.1	0.29	0.77	0.82
5780.1	5810.1	0.24	0.59	0.69
6000.1	6030.1	0.72	0.94	0.99
6220.1	6250.1	0.90	1.12	1.07
6440.1	6470.1	0.78	1.15	1.05
6660.1	6690.1	0.52	1.15	1.04
6880.1	6910.1	0.06	1.14	1.09
7100.1	7130.1	0.21	1.35	1.25
7320.1	7350.1	0.73	1.55	1.38
7520.1	7550.1	0.30	1.22	1.13
7740.1	7770.1	-1.39	0.46	0.78
7960.1	7990.1	-4.45	-0.72	0.38
8180.1	8210.1	-9.20	-3.36	-0.37

Wideband Double Balanced Mixer-Amplifier

MDA4-752H+

Typical Performance Data

IF (OUT) (MHz)	LO (MHz)	CONVERSION GAIN VS. IF FREQUENCY @RF(IN)=4900.1MHz (dB)
		@LO (dBm)
		0
1760.0	3140.1	1.15
1680.0	3220.1	2.71
1590.0	3310.1	3.67
1500.0	3400.1	3.75
1410.0	3490.1	3.30
1320.0	3580.1	2.98
1230.0	3670.1	2.92
1140.0	3760.1	3.11
1050.0	3850.1	3.36
960.0	3940.1	3.45
870.0	4030.1	3.61
780.0	4120.1	3.88
690.0	4210.1	4.30
600.0	4300.1	4.80
510.0	4390.1	5.27
420.0	4480.1	5.55
330.0	4570.1	5.66
240.0	4660.1	5.70
150.0	4750.1	5.73
60.0	4840.1	6.43
100.0	5000.1	5.91
190.0	5090.1	5.70
270.0	5170.1	5.69
360.0	5260.1	5.58
440.0	5340.1	5.50
530.0	5430.1	5.29
610.0	5510.1	4.99
700.0	5600.1	4.50
780.0	5680.1	4.06
870.0	5770.1	3.67
950.0	5850.1	3.51
1040.0	5940.1	3.36
1120.0	6020.1	3.12
1210.0	6110.1	3.12
1290.0	6190.1	3.21
1380.0	6280.1	3.09
1460.0	6360.1	2.71
1550.0	6450.1	2.20
1630.0	6530.1	1.35

IF (OUT) (MHz)	LO (MHz)	CONVERSION GAIN VS. IF FREQUENCY @RF(IN)=2300.1MHz (dB)
		@LO (dBm)
		0
10.0	2310.1	6.93
50.0	2350.1	7.32
90.0	2390.1	6.55
140.0	2440.1	6.18
180.0	2480.1	6.10
220.0	2520.1	6.04
270.0	2570.1	6.02
310.0	2610.1	5.98
350.0	2650.1	5.91
400.0	2700.1	5.86
440.0	2740.1	5.77
480.0	2780.1	5.63
530.0	2830.1	5.46
570.0	2870.1	5.24
610.0	2910.1	5.13
660.0	2960.1	4.74
700.0	3000.1	4.50
740.0	3040.1	4.35
790.0	3090.1	4.05
830.0	3130.1	4.06
920.0	3220.1	4.02
960.0	3260.1	3.98
1000.0	3300.1	4.02
1050.0	3350.1	3.91
1090.0	3390.1	3.89
1130.0	3430.1	3.90
1170.0	3470.1	3.69
1220.0	3520.1	3.79
1260.0	3560.1	3.66
1310.0	3610.1	3.88
1350.0	3650.1	3.89
1390.0	3690.1	4.11
1440.0	3740.1	4.25
1480.0	3780.1	4.45
1520.0	3820.1	4.48
1570.0	3870.1	4.32
1610.0	3910.1	3.97
1650.0	3950.1	3.37
1700.0	4000.1	2.36

IF (OUT) (MHz)	LO (MHz)	CONVERSION GAIN VS. IF FREQUENCY @RF(IN)=7500.1MHz (dB)
		@LO (dBm)
		0
2000.0	5500.1	-9.19
1950.0	5550.1	-7.77
1900.0	5600.1	-6.07
1850.0	5650.1	-4.38
1800.0	5700.1	-2.84
1750.0	5750.1	-1.21
1700.0	5800.1	-0.02
1650.0	5850.1	1.02
1600.0	5900.1	1.69
1550.0	5950.1	2.17
1500.0	6000.1	2.52
1450.0	6050.1	2.71
1400.0	6100.1	2.93
1340.0	6160.1	3.09
1290.0	6210.1	3.21
1240.0	6260.1	3.18
1190.0	6310.1	3.26
1140.0	6360.1	3.21
1090.0	6410.1	3.16
1040.0	6460.1	3.12
940.0	6560.1	3.06
890.0	6610.1	3.04
840.0	6660.1	3.22
790.0	6710.1	3.15
740.0	6760.1	3.43
680.0	6820.1	3.30
630.0	6870.1	3.59
580.0	6920.1	3.40
530.0	6970.1	3.70
480.0	7020.1	3.44
430.0	7070.1	3.66
380.0	7120.1	3.31
330.0	7170.1	3.40
280.0	7220.1	2.97
230.0	7270.1	2.96
180.0	7320.1	2.49
130.0	7370.1	2.58
80.0	7420.1	2.40
20.0	7480.1	6.16

Typical Performance Data

LO (MHz)	LO-RF ISOLATION (dB)			LO-IF ISOLATION (dB)		
	@LO (dBm)			@LO (dBm)		
	-3	0	+3	-3	0	+3
1030.1	20.73	24.16	26.52	0.60	0.59	1.17
1230.1	24.00	26.93	29.33	0.46	0.45	0.97
1450.1	25.03	26.76	28.01	0.72	0.71	0.95
1670.1	30.60	30.62	30.14	2.56	2.56	2.66
1890.1	26.69	23.65	22.66	9.15	9.15	8.88
2110.1	28.43	23.68	22.07	17.32	17.32	15.93
2330.1	25.21	22.53	21.70	22.81	22.80	21.66
2550.1	21.78	21.23	21.64	27.48	27.48	27.46
2770.1	21.26	21.20	22.32	32.33	32.32	33.10
2990.1	19.33	20.45	23.05	36.57	36.58	37.83
3190.1	18.90	20.13	24.05	37.91	37.89	39.71
3410.1	24.73	26.60	33.93	37.84	37.83	39.91
3630.1	25.68	29.11	42.93	46.42	46.42	48.79
3850.1	27.21	34.43	40.04	57.84	58.01	60.80
4070.1	27.38	32.09	40.86	64.72	64.32	67.01
4290.1	27.88	30.24	35.23	67.85	67.35	70.42
4510.1	27.48	29.80	33.52	67.30	66.39	69.34
4730.1	27.45	30.55	34.87	65.88	65.67	67.86
4950.1	25.18	25.96	28.29	65.06	65.39	66.91
5170.1	23.11	22.98	24.20	62.25	62.00	64.15
5370.1	22.34	22.59	23.70	61.10	61.43	63.58
5590.1	21.09	22.06	23.57	61.58	61.41	63.92
5810.1	20.01	21.41	23.22	59.82	59.69	61.77
6030.1	19.40	20.85	22.66	59.05	58.95	60.95
6250.1	18.68	20.04	21.78	58.06	58.16	59.84
6470.1	18.35	19.62	21.27	55.55	55.59	57.35
6690.1	17.88	18.86	20.42	54.00	54.12	55.37
6910.1	17.89	18.73	20.16	54.56	54.71	55.75
7130.1	18.50	19.41	20.81	55.37	55.11	56.36
7350.1	20.41	21.21	22.47	59.37	59.35	60.52
7550.1	24.13	24.21	24.55	64.31	63.14	66.29
7770.1	33.38	27.73	25.42	68.83	68.76	68.94
7990.1	22.89	23.00	23.19	66.91	66.15	66.53
8210.1	16.30	16.84	18.08	63.43	63.74	64.11

RF (IN) (MHz)	LO (MHz)	RF-IF ISOLATION (dB)		
		@LO (dBm)		
		-3	0	+3
1000.1	1030.1	-2.25	-1.47	-0.88
1200.1	1230.1	-3.00	-2.05	-1.37
1420.1	1450.1	-4.55	-4.06	-3.88
1640.1	1670.1	-4.77	-4.26	-4.16
1860.1	1890.1	-0.03	0.07	-0.10
2080.1	2110.1	5.83	5.52	5.20
2300.1	2330.1	10.85	10.53	10.38
2520.1	2550.1	15.96	15.74	15.65
2740.1	2770.1	21.52	21.32	21.30
2960.1	2990.1	26.44	26.41	26.51
3160.1	3190.1	29.05	28.98	29.03
3380.1	3410.1	28.73	28.50	28.36
3600.1	3630.1	34.39	33.98	33.93
3820.1	3850.1	46.19	45.48	45.35
4040.1	4070.1	55.28	54.12	54.62
4260.1	4290.1	59.86	60.68	60.98
4480.1	4510.1	64.70	64.06	62.79
4700.1	4730.1	63.98	64.07	71.90
4920.1	4950.1	69.35	66.94	67.32
5140.1	5170.1	67.10	69.81	68.35
5340.1	5370.1	66.91	61.88	64.31
5560.1	5590.1	60.93	63.56	64.17
5780.1	5810.1	59.00	62.41	60.04
6000.1	6030.1	57.88	58.51	58.37
6220.1	6250.1	53.97	56.93	55.83
6440.1	6470.1	51.14	51.57	51.71
6660.1	6690.1	48.82	49.72	50.55
6880.1	6910.1	49.95	50.76	50.61
7100.1	7130.1	51.31	50.66	51.51
7320.1	7350.1	51.70	52.41	53.15
7520.1	7550.1	52.95	52.46	54.78
7740.1	7770.1	53.94	54.52	54.41
7960.1	7990.1	56.31	56.69	57.25
8180.1	8210.1	58.84	56.87	57.77

Wideband Double Balanced Mixer-Amplifier

MDA4-752H+

Typical Performance Data

RF (IN) (MHz)	LO (MHz)	RF VSWR (:1)			LO (MHz)	LO VSWR (:1)			IF (OUT) (MHz)	IF VSWR @LO=7530.1MHz (:1)		
		@LO (dBm)				@LO (dBm)				@LO (dBm)		
		-3	0	+3		-3	0	+3		-3	0	+3
1000.1	1030.1	6.39	6.36	6.38	1030.1	1.26	1.27	1.40	10.1	4.26	3.88	4.00
1200.1	1230.1	5.94	6.17	6.26	1230.1	1.16	1.12	1.27	110.1	4.06	4.00	3.96
1420.1	1450.1	6.33	6.35	6.32	1450.1	1.22	1.17	1.24	210.1	3.27	3.25	3.21
1640.1	1670.1	4.87	4.86	4.78	1670.1	1.22	1.21	1.28	310.1	2.78	2.78	2.73
1860.1	1890.1	3.96	3.86	3.73	1890.1	1.11	1.17	1.28	410.1	3.12	3.11	3.08
2080.1	2110.1	3.59	3.51	3.42	2110.1	1.04	1.14	1.24	520.1	4.37	4.33	4.27
2300.1	2330.1	2.97	3.01	3.02	2330.1	1.16	1.14	1.18	620.1	5.48	5.44	5.38
2520.1	2550.1	2.41	2.49	2.56	2550.1	1.28	1.17	1.13	720.1	5.83	5.76	5.73
2740.1	2770.1	1.93	1.98	2.03	2770.1	1.40	1.23	1.13	820.1	5.20	5.16	5.11
2960.1	2990.1	1.60	1.59	1.60	2990.1	1.46	1.25	1.12	930.1	3.80	3.78	3.75
3160.1	3190.1	1.49	1.49	1.48	3190.1	1.52	1.27	1.10	1030.1	2.47	2.47	2.46
3380.1	3410.1	1.26	1.29	1.32	3410.1	1.59	1.29	1.06	1130.1	1.55	1.55	1.55
3600.1	3630.1	1.06	1.15	1.18	3630.1	1.70	1.33	1.05	1230.1	1.32	1.32	1.33
3820.1	3850.1	1.14	1.12	1.15	3850.1	1.88	1.43	1.06	1340.1	1.71	1.70	1.71
4040.1	4070.1	1.57	1.42	1.38	4070.1	1.92	1.47	1.12	1440.1	1.83	1.83	1.82
4260.1	4290.1	2.02	1.80	1.75	4290.1	1.96	1.53	1.20	1540.1	1.45	1.45	1.45
4480.1	4510.1	2.45	2.11	2.03	4510.1	1.89	1.53	1.24	1640.1	1.29	1.30	1.30
4700.1	4730.1	2.76	2.34	2.24	4730.1	1.76	1.47	1.26	1740.1	3.33	3.33	3.34
4920.1	4950.1	2.96	2.48	2.37	4950.1	1.61	1.37	1.30	1850.1	8.87	8.86	8.85
5140.1	5170.1	3.12	2.63	2.50	5170.1	1.47	1.32	1.37	1950.1	16.45	16.44	16.38
5340.1	5370.1	3.09	2.69	2.54	5370.1	1.42	1.36	1.51	2050.1	23.90	23.90	24.01
5560.1	5590.1	3.07	2.79	2.66	5590.1	1.52	1.54	1.71	2150.1	30.01	30.07	29.86
5780.1	5810.1	2.96	2.75	2.66	5810.1	1.83	1.84	2.01	2260.1	35.27	35.42	34.95
6000.1	6030.1	2.60	2.40	2.32	6030.1	2.31	2.28	2.41	2360.1	38.29	37.69	37.69
6220.1	6250.1	2.25	2.04	1.95	6250.1	2.97	2.83	2.88	2500.1	41.28	41.06	41.41
6440.1	6470.1	2.00	1.80	1.71	6470.1	3.59	3.31	3.29	2560.1	41.55	41.26	41.54
6660.1	6690.1	1.86	1.69	1.60	6690.1	3.96	3.65	3.61	2670.1	43.66	43.96	43.95
6880.1	6910.1	2.03	1.82	1.72	6910.1	3.93	3.71	3.68	2770.1	45.40	45.68	45.14
7100.1	7130.1	2.34	2.08	1.96	7130.1	3.60	3.55	3.60	2870.1	45.86	45.42	45.37
7320.1	7350.1	2.63	2.36	2.24	7350.1	3.27	3.34	3.45	2970.1	46.34	45.99	46.13
7520.1	7550.1	2.95	2.67	2.53	7550.1	3.03	3.15	3.29	3070.1	43.25	43.30	43.17
7740.1	7770.1	3.26	2.96	2.78	7770.1	2.84	2.94	3.08	3180.1	44.42	44.35	44.49
7960.1	7990.1	3.32	3.09	2.91	7990.1	2.71	2.77	2.87	3280.1	45.56	45.99	45.94
8180.1	8210.1	2.93	2.85	2.72	8210.1	2.54	2.56	2.65	3380.1	47.08	47.08	46.82

Harmonics Tables

RF HARMONICS ORDER

	(-dBm)	(-dBc)										
0	---	---	62.97	76.13	56.11	59.52	65.19	---	---	---	---	---
1	---	75.76	---	99.40	103.05	70.24	97.58	92.61	---	---	---	---
2	116.22	104.13	103.43	62.14	106.55	101.63	101.66	98.20	94.13	---	---	---
3	115.35	99.82	104.16	104.49	70.53	104.70	102.05	102.75	97.14	95.24	93.27	---
4	109.79	98.09	100.72	103.04	103.66	106.14	102.67	104.83	101.59	99.56	95.85	---
5	110.96	97.39	97.90	102.18	103.37	102.95	101.62	104.73	103.59	98.58	97.97	95.39
6	107.35	---	94.02	98.61	102.89	103.78	103.17	99.61	103.61	103.14	101.77	98.04
7	107.94	---	---	96.64	96.30	102.04	103.95	102.22	97.28	102.66	103.32	98.91
8	108.10	---	---	---	98.01	98.58	100.99	102.36	104.30	101.67	102.71	103.58
9	108.61	---	---	---	---	96.78	98.48	103.27	102.66	104.17	102.18	102.85
10	105.11	---	---	---	---	---	96.74	97.92	102.98	105.23	104.02	108.05
	RF CAL	0	1	2	3	4	5	6	7	8	9	10

LO HARMONICS ORDER

Test conditions: RF IN: 4600.1 MHz; -15 dBm.
 LO IN: 4630.1 MHz; 0 dBm
 IF OUT: 30 MHz; -6.58 dBm

RF HARMONICS ORDER

	(-dBm)	(-dBc)										
0	---	---	73.01	85.89	66.05	69.14	75.99	---	---	---	---	---
1	---	76.23	---	97.03	107.77	70.35	97.11	98.56	---	---	---	---
2	102.04	109.87	112.49	51.33	114.12	111.83	104.19	101.15	102.49	---	---	---
3	110.23	103.44	110.51	113.48	52.05	111.14	110.91	106.31	106.34	103.12	102.33	---
4	107.47	105.95	109.60	111.57	109.83	73.91	111.38	111.84	110.72	106.67	100.83	---
5	105.63	102.63	106.87	107.33	111.42	110.20	79.84	112.41	110.97	108.80	105.73	103.15
6	102.94	---	106.84	107.49	108.02	112.01	112.72	90.84	111.77	113.29	108.12	105.73
7	103.85	---	---	103.29	106.15	109.99	112.08	108.75	94.49	110.83	111.10	108.65
8	104.68	---	---	---	103.68	105.93	109.26	110.69	112.10	101.11	111.84	111.24
9	103.58	---	---	---	---	103.97	106.13	107.59	112.47	110.71	101.05	110.06
10	104.42	---	---	---	---	---	102.45	107.06	112.35	111.62	112.62	111.85
	RF CAL	0	1	2	3	4	5	6	7	8	9	10

LO HARMONICS ORDER

Test conditions: RF IN: 4600.1 MHz; -5 dBm.
 LO IN: 4630.1 MHz; 0 dBm
 IF OUT: 30 MHz; 3.27dBm

- Notes: 1. All Harmonics are in (dBc) relative to IF OUTPUT
 2. + entry denotes harmonics are in (dBc) above IF OUTPUT
 3. RF Cal represents the Harmonics level of the RF Input Signal to the mixer

Wideband Double Balanced Mixer-Amplifier

Typical Performance Curves

MDA4-752H+

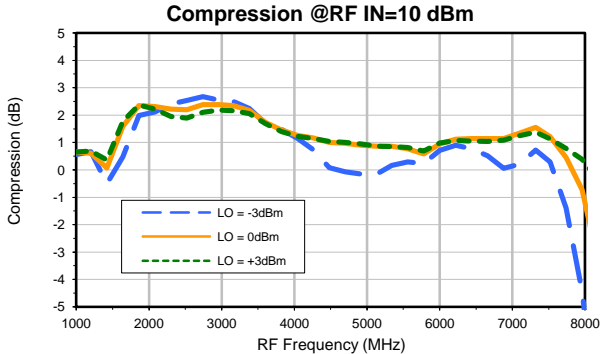
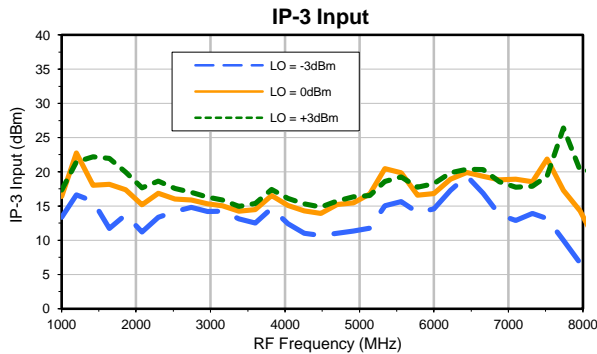
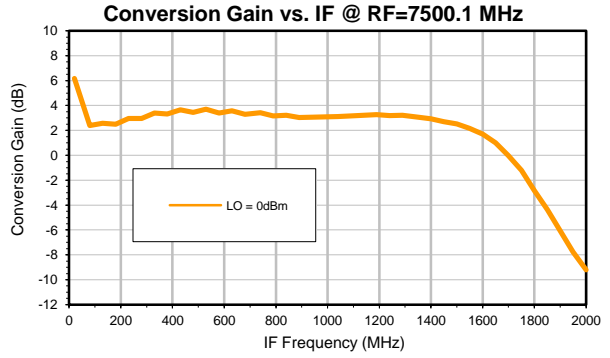
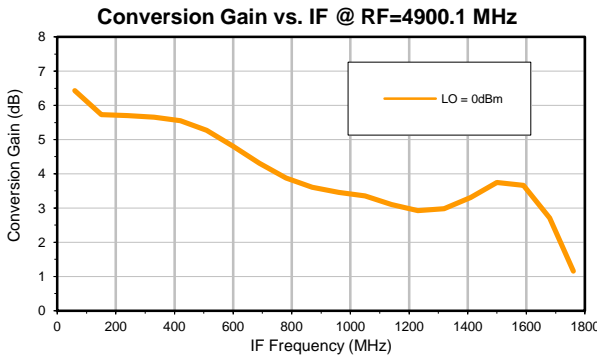
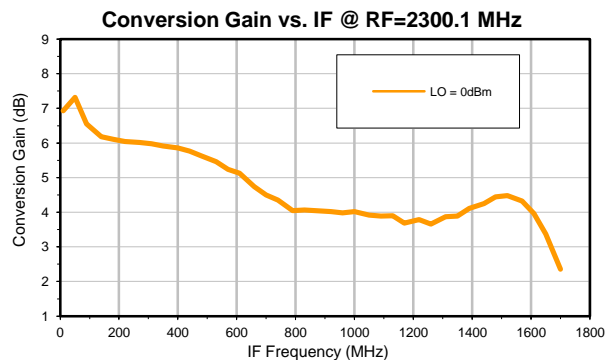
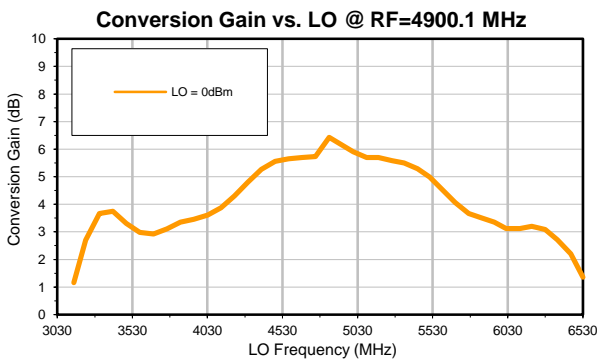
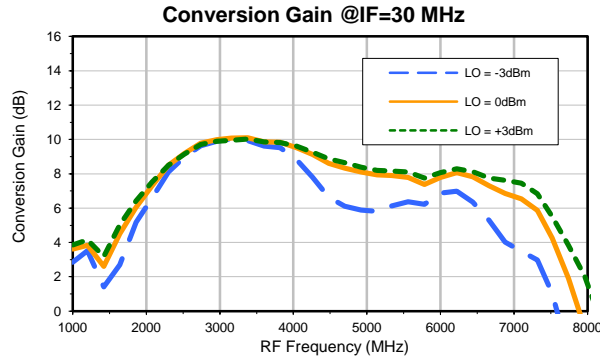

P.O. Box 350166, Brooklyn, New York 11235-0003 • Fax (718) 934-4500 • Fax (718) 332-4661 For detailed performance specs & shopping online see Mini-Circuits web site



The Design Engineers Search Engine Provides ACTUAL Data Instantly From MINI-CIRCUITS At: www.minicircuits.com

IF/RF MICROWAVE COMPONENTS

REV. OR
MADA4-752H+
1/26/2015
Page 1 of 3

Wideband Double Balanced Mixer-Amplifier

Typical Performance Curves

MDA4-752H+

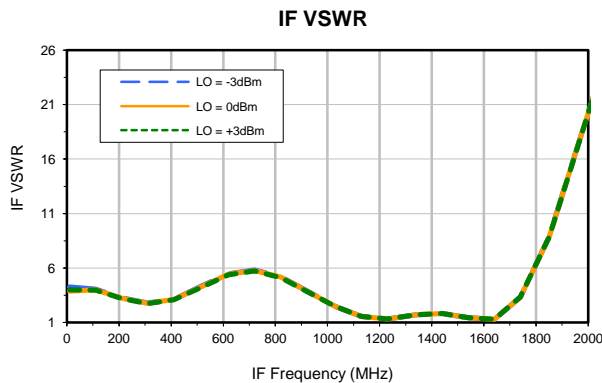
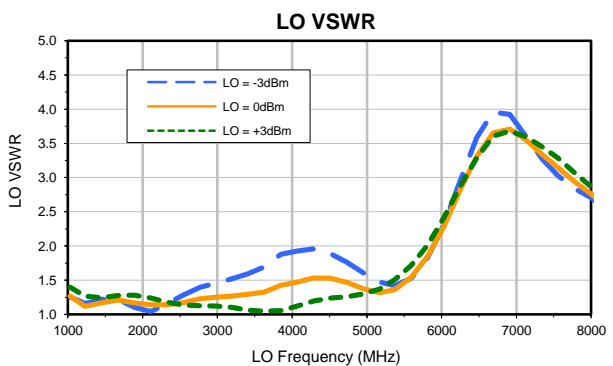
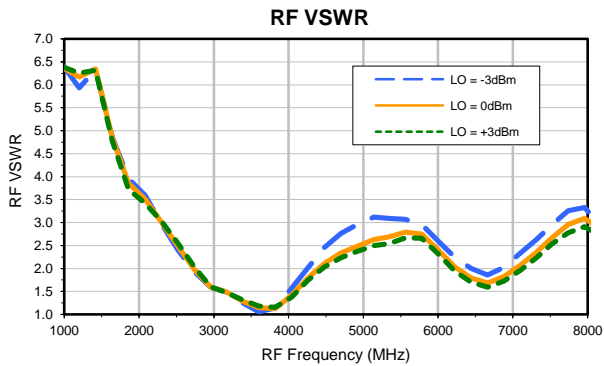
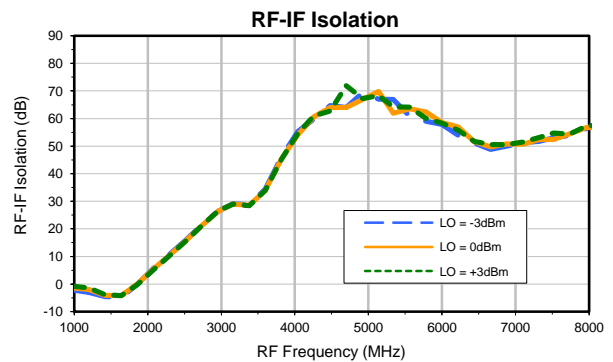
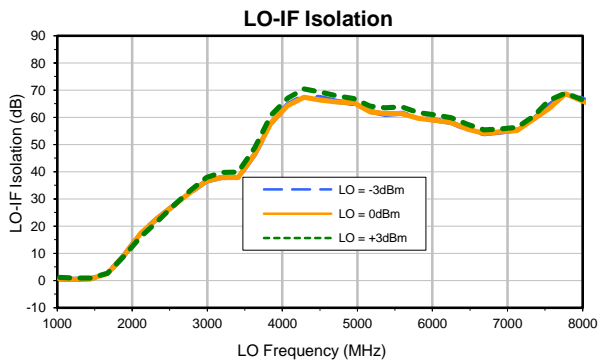
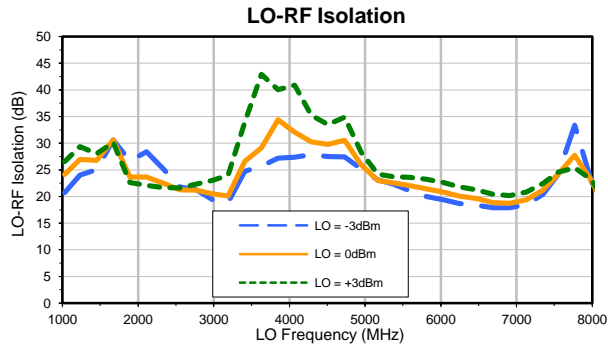

Harmonics Tables

RF HARMONICS ORDER	(-dBm)	(-dBc)										
	RF CAL	0	1	2	3	4	5	6	7	8	9	10
0	---	---	62.97	76.13	56.11	59.52	65.19	---	---	---	---	---
1	---	75.76	---	99.40	103.05	70.24	97.58	92.61	---	---	---	---
2	116.22	104.13	103.43	62.14	106.55	101.63	101.66	98.20	94.13	---	---	---
3	115.35	99.82	104.16	104.49	70.53	104.70	102.05	102.75	97.14	95.24	93.27	---
4	109.79	98.09	100.72	103.04	103.66	106.14	102.67	104.83	101.59	99.56	95.85	---
5	110.96	97.39	97.90	102.18	103.37	102.95	101.62	104.73	103.59	98.58	97.97	95.39
6	107.35	---	94.02	98.61	102.89	103.78	103.17	99.61	103.61	103.14	101.77	98.04
7	107.94	---	---	96.64	96.30	102.04	103.95	102.22	97.28	102.66	103.32	98.91
8	108.10	---	---	---	98.01	98.58	100.99	102.36	104.30	101.67	102.71	103.58
9	108.61	---	---	---	---	96.78	98.48	103.27	102.66	104.17	102.18	102.85
10	105.11	---	---	---	---	---	96.74	97.92	102.98	105.23	104.02	108.05

LO HARMONICS ORDER

Test conditions: RF IN: 4600.1 MHz; -15 dBm.
LO IN: 4630.1 MHz; 0 dBm
IF OUT: 30 MHz; -6.58 dBm

RF HARMONICS ORDER	(-dBm)	(-dBc)										
	RF CAL	0	1	2	3	4	5	6	7	8	9	10
0	---	---	73.01	85.89	66.05	69.14	75.99	---	---	---	---	---
1	---	76.23	---	97.03	107.77	70.35	97.11	98.56	---	---	---	---
2	102.04	109.87	112.49	51.33	114.12	111.83	104.19	101.15	102.49	---	---	---
3	110.23	103.44	110.51	113.48	52.05	111.14	110.91	106.31	106.34	103.12	102.33	---
4	107.47	105.95	109.60	111.57	109.83	73.91	111.38	111.84	110.72	106.67	100.83	---
5	105.63	102.63	106.87	107.33	111.42	110.20	79.84	112.41	110.97	108.80	105.73	103.15
6	102.94	---	106.84	107.49	108.02	112.01	112.72	90.84	111.77	113.29	108.12	105.73
7	103.85	---	---	103.29	106.15	109.99	112.08	108.75	94.49	110.83	111.10	108.65
8	104.68	---	---	---	103.68	105.93	109.26	110.69	112.10	101.11	111.84	111.24
9	103.58	---	---	---	---	103.97	106.13	107.59	112.47	110.71	101.05	110.06
10	104.42	---	---	---	---	---	102.45	107.06	112.35	111.62	112.62	111.85

LO HARMONICS ORDER

Test conditions: RF IN: 4600.1 MHz; -5 dBm.
LO IN: 4630.1 MHz; 0 dBm
IF OUT: 30 MHz; 3.27dBm

- Notes: 1. All Harmonics are in (dBc) relative to IF OUTPUT
2. + entry denotes harmonics are in (dBc) above IF OUTPUT
3. RF Cal represents the Harmonics level of the RF Input Signal to the mixer

Tape & Reel Packaging TR-F68

DEVICE ORIENTATION IN T&R

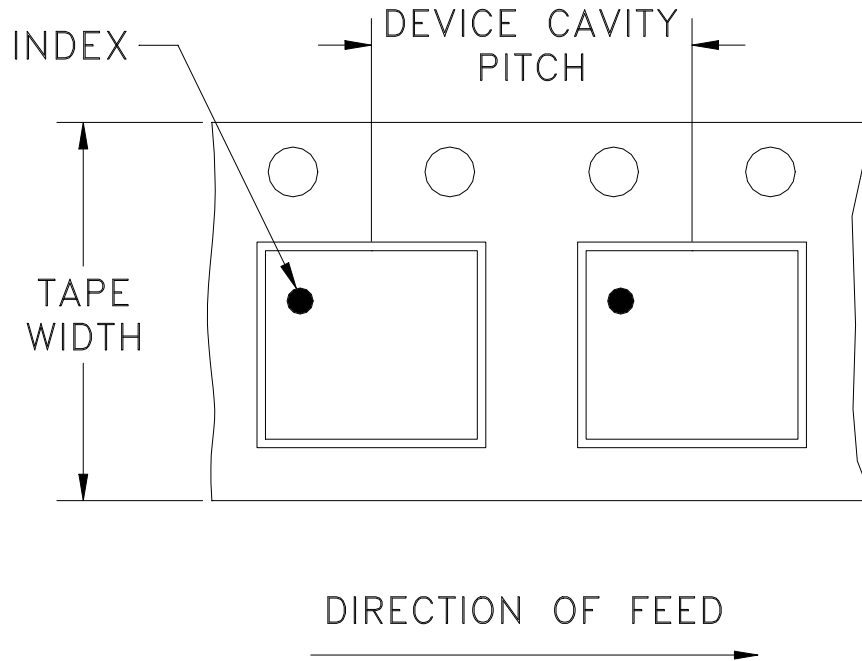

Tape Width, mm	Device Cavity Pitch, mm	Reel Size, inches	Devices per Reel see note	
12	8	7	Small quantity standard	20
				50
				100
				200
				500
		7	Standard	1000
		13	Standard	2000
				3000
				4000

Mini-Circuits carrier tape materials provide protection from ESD (Electro-Static Discharge) during handling and transportation. Tapes are static dissipative and comply with industry standards EIA-481/EIA-541.

Go to: www.minicircuits.com/pages/pdfs/tape.pdf



INTERNET <http://www.minicircuits.com>

P.O. Box 350166, Brooklyn, New York 11235-0003 (718) 934-4500 Fax (718) 332-4661

Distribution Centers NORTH AMERICA 800-654-7949 • 417-335-5935 • Fax 417-335-5945 • EUROPE 44-1252-832600 • Fax 44-1252-837010

Mini-Circuits ISO 9001 & ISO 14001 Certified

THIRD ANGLE PROJECTION

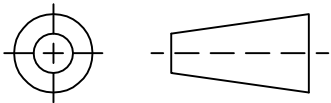

REVISIONS

REV	ECN No.	DESCRIPTION	DATE	DR	AUTH
OR	M148056	NEW RELEASE	09/22/14	ITG	RS

SUGGESTED MOUNTING CONFIGURATION
FOR DG1847 CASE STYLE, "24MX02" PIN CODE

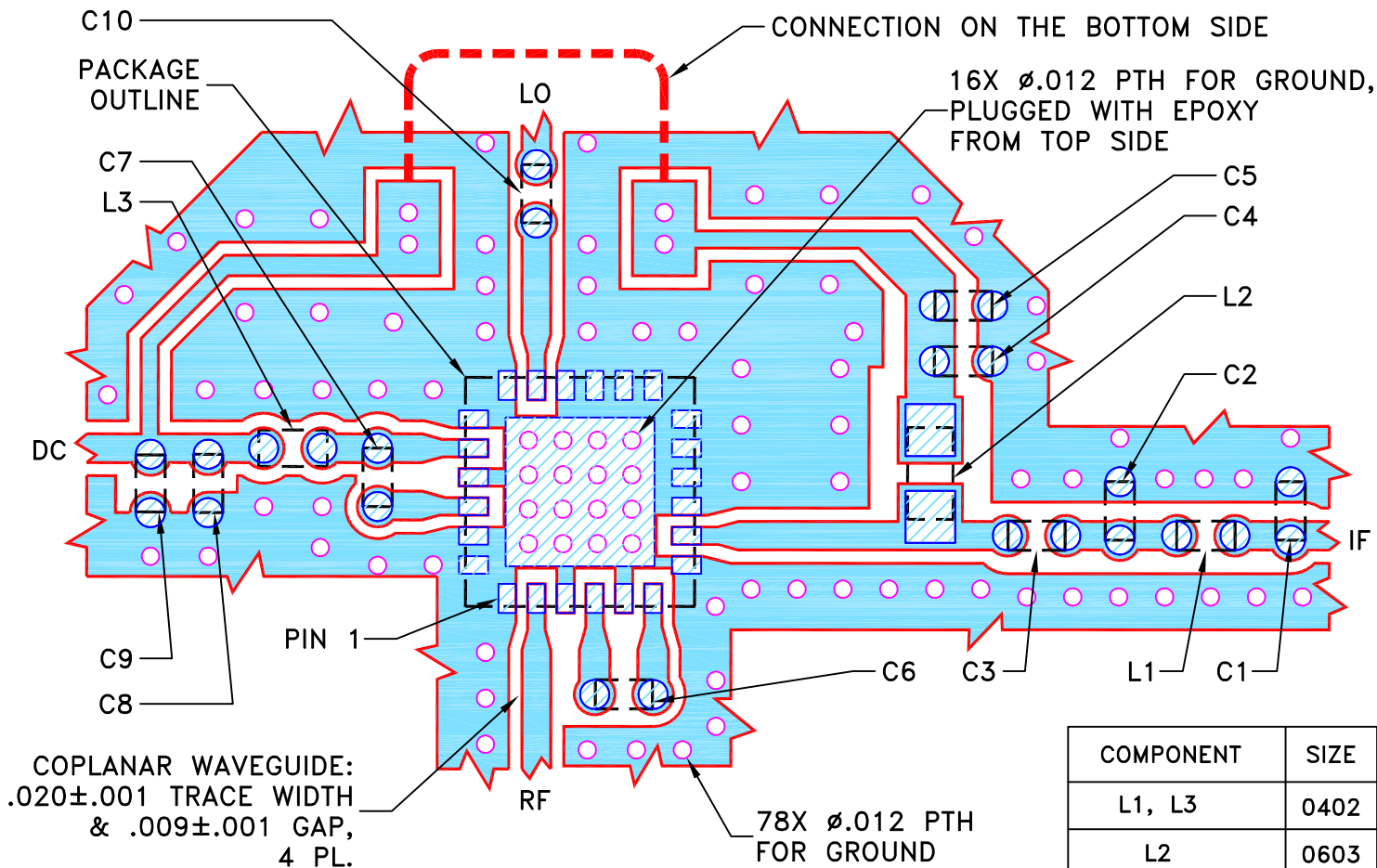

COMPONENT	SIZE
L1, L3	0402
L2	0603
C1-C10	0402

NOTES:

1. TRACE WIDTH & GAP PARAMETERS ARE SHOWN FOR ROGERS RO4350B WITH DIELECTRIC THICKNESS .010"±.001". COPPER: 1/2 OZ. EACH SIDE. FOR OTHER MATERIALS TRACE WIDTH & GAP MAY NEED TO BE MODIFIED.
2. CHIP COMPONENT FOOT PRINTS SHOWN FOR REFERENCE. FOR COMPONENT VALUES REFER TO TB-771+.
3. BOTTOM SIDE OF THE PCB IS CONTINUOUS GROUND PLANE EXCEPT OF THE NECESSARY CONNECTION AS SHOWN ABOVE.

- DENOTES PCB COPPER LAYOUT WITH SMOBC (SOLDER MASK OVER BARE COPPER).
- DENOTES COPPER LAND PATTERN FREE OF SOLDER MASK.

UNLESS OTHERWISE SPECIFIED	INITIALS		DATE
DIMENSIONS ARE IN INCHES	DRAWN	ITG	09/04/14
TOLERANCES ON:	CHECKED	GF	09/22/14
2 PL DECIMALS ±	APPROVED	RS	09/22/14
3 PL DECIMALS ± .005			
ANGLES ±			
FRACTIONS ±			

Mini-Circuits® 13 Neptune Avenue
Brooklyn NY 11235

PL, 24MX02, DG1847, TB-771+

Mini-Circuits®
THIS DOCUMENT AND ITS CONTENTS ARE THE PROPERTY OF MINI-CIRCUITS. EXCEPT FOR USE EXPRESSLY GRANTED, IN WRITING, TO ITS VENDORS, VENDEE AND THE UNITED STATES GOVERNMENT, MINI-CIRCUITS RESERVES ALL PROPRIETARY DESIGN, USE, MANUFACTURING AND REPRODUCTION RIGHTS THERETO. THESE CONTENTS SHALL NOT BE USED, DUPLICATED OR DISCLOSED TO ANY OUTSIDE PARTY, IN WHOLE OR IN PART, WITHOUT WRITTEN PERMISSION OF MINI-CIRCUITS.

SIZE	CODE IDENT	DRAWING NO:	REV:
A	15542	98-PL-433	OR
FILE:	98PL433	SCALE: 8:1	SHEET: 1 OF 1

Evaluation Board and Circuit

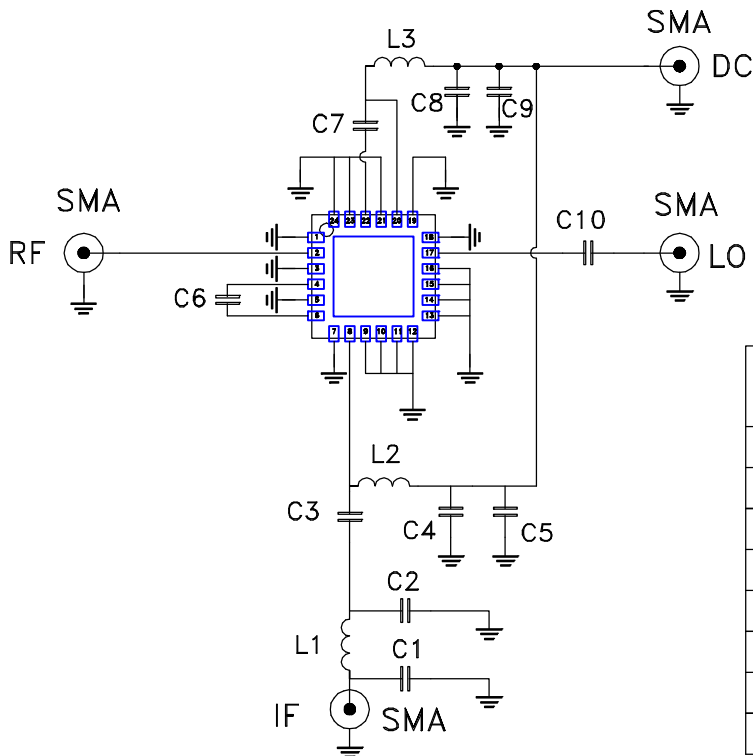
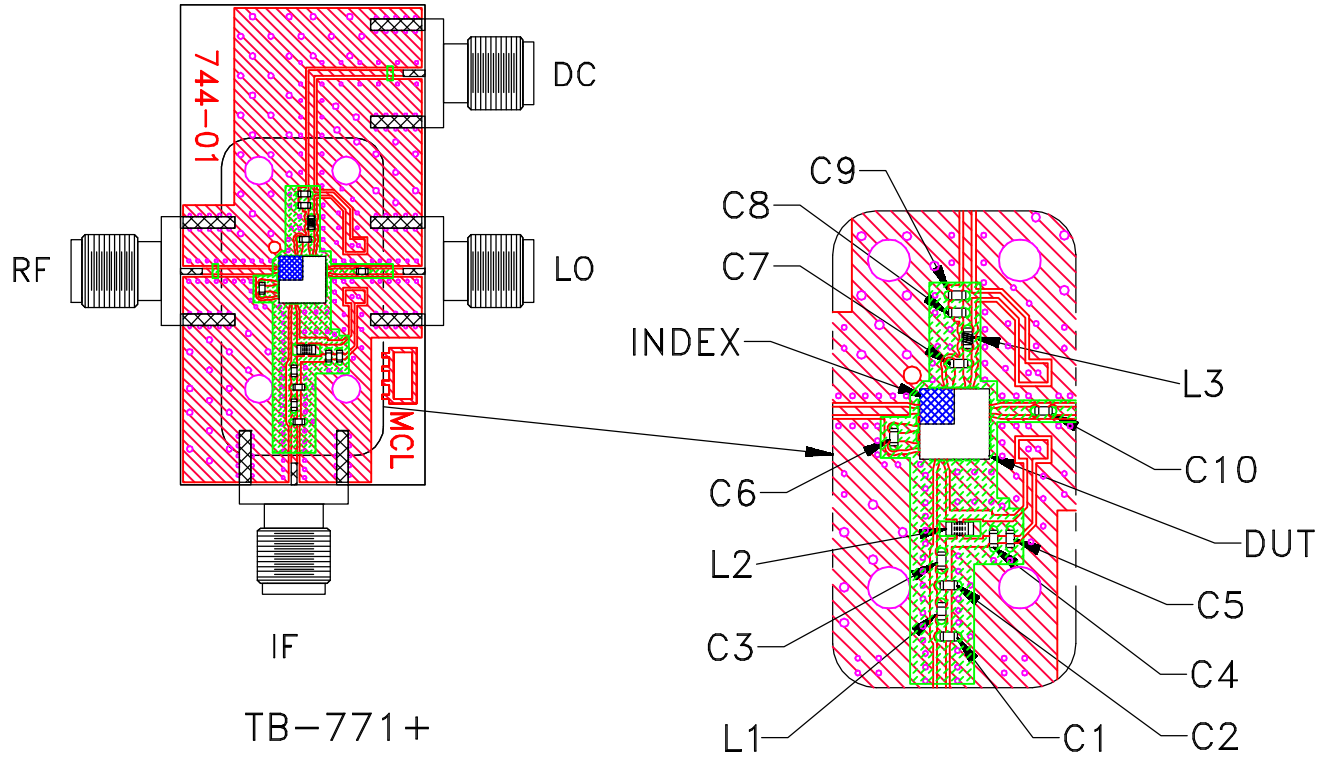

COMPONENT	VALUE	SIZE
DUT	MDA4-752H+	4X4 MM
L1	4.7nH	0402
L2	390nH	0603
L3	36nH	0402
C1,C2	3pF	0402
C3,C6	.01uF	0402
C4,C7,C8,C10	100pF	0402
C5,C9	0.1uF	0402

Schematic Diagram

Notes:

1. 50 Ohm SMA Female connectors.
2. PCB Material: R04350 or equivalent,
Dielectric Constant=3.5, Thickness=.010 inch.

 **Mini-Circuits®**

All Mini-Circuits products are manufactured under exacting quality assurance and control standards, and are capable of meeting published specifications after being subjected to any or all of the following physical and environmental test.

Specification	Test/Inspection Condition	Reference/Spec
Operating Temperature	-40° to 85°C or -45° to 85°C Ambient Environment	Individual Model Data Sheet
Storage Temperature	-55° to 100° C or -65° to 150° Ambient Environment	Individual Model Data Sheet
Thermal Shock	-55° to 100°C, 100 cycles	MIL-STD-202, Method 107, Condition A-3, except +100°C
Mechanical Shock	1.5Kg, 0.5 ms, 5 shock pulses, Y1 direction only	MIL-STD-883, Method 2002, Condition B, except Y1 direction only
Vibration (Variable Frequency)	50g peak	MIL-STD-883, Method 2007, Condition B
Autoclave	15 psig, 100% RH, 121°C, 96 hours	JESD22-A102, Condition C
HAST	130°C, 85% RH, 96 hours	JESD22-A110
Solderability	10X Magnification	J-STD-002, Para 4.2.5, Test S, 95% Coverage
Solder Reflow Heat	Sn-Pb Eutetic Process: 240°C peak Pb-Free Process: 260°C peak	J-STD-020, Table 4-1, 4-2 and 5-2; Figure 5-1
Moisture Sensitivity: Level 1	Bake at 125°C for 24 hours Soak at 85°C/85% RH for 168 hours, Reflow 3 cycles at 260°C peak	J-STD-020
Marking Resistance to Solvents	Isopropyl alcohol + mineral spirits at 25°C; terpene defluxer at 25°C; distilled water + proylene glycol monomethyl ether +	MIL-STD-202, Method 215



All Mini-Circuits products are manufactured under exacting quality assurance and control standards, and are capable of meeting published specifications after being subjected to any or all of the following physical and environmental test.

Specification	Test/Inspection Condition	Reference/Spec
	monoethanolamine at 63°C to 70°C	