



MMIC DIE

# Wideband Amplifier LVA-273PN-D+

50Ω 0.01 to 26.5GHz Ultra-Low Phase Noise

## THE BIG DEAL

- Wide Bandwidth 0.01 to 26.5GHz
- Ultra-low Phase Noise Typ. -172dBc/Hz @ 10kHz Offset
- Output P1dB Typ. +18dBm
- Output IP3 Typ. +28dBm
- Supply Voltage: +5V and 85mA

## APPLICATIONS

- Test and Measurement Equipment
- Radar, EW, and ECM Defense Systems
- 5G MIMO and Back Haul Radio Systems
- Signal Distribution Networks

## FUNCTIONAL DIAGRAM

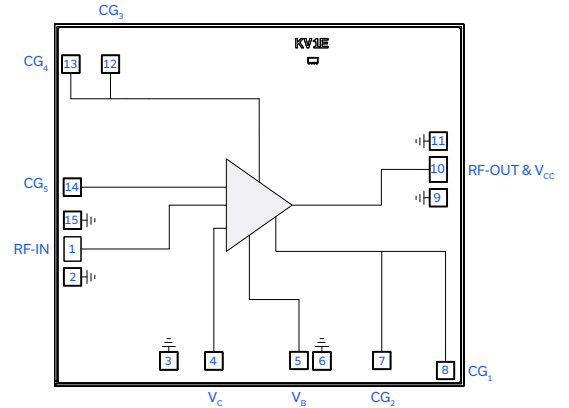

SEE ORDERING INFORMATION ON THE LAST PAGE

## PRODUCT OVERVIEW

Mini-Circuits LVA-273PN-D+ is an ultra-low phase noise distributed MMIC amplifier die fabricated on a GaAs HBT process technology. Operating from 0.01 to 26.5GHz, this amplifier features high dynamic range and ultra-low phase noise along with 18dB gain, +18dBm P1dB, +28dBm OIP3, and 3.7dB noise figure. The LVA-273PN-D+ is ideal for use with low noise signal sources and highly sensitive transceiver signal chains for commercial, industrial, and defense applications.

## KEY FEATURES

Features	Advantages
Wide Bandwidth: 0.01 to 26.5GHz	Supports a broad variety of applications including Test and Measurement Equipment, 5G Microwave Radio, Radar, and Electronic Warfare Systems.
Ultra-low Phase Noise: -172dBc/Hz @10kHz offset	Enables the detection of signal levels in the presence of noise.
High Dynamic Range: <ul style="list-style-type: none"> <li>• +18dBm P1dB</li> <li>• 18dB Gain</li> <li>• 3.7dB Noise Figure</li> </ul>	The MMIC amplifier's unique combinations of ultra-low phase noise, high operating P1dB, high Gain, and low noise figure features enable optimum performance for high dynamic range transceiver systems.

REV. OR  
ECO-019223  
LVA-273PN-D+  
MCL NY  
230915



**MMIC DIE**

# Wideband Amplifier **LVA-273PN-D+**

50Ω 0.01 to 26.5GHz Ultra-Low Phase Noise

**ELECTRICAL SPECIFICATIONS<sup>1</sup> AT +25°C, V<sub>CC</sub> = +5V, V<sub>C</sub> = +5V, V<sub>B</sub> = +5V, & Z<sub>0</sub> = 50Ω UNLESS NOTED OTHERWISE**

Parameter	Condition (GHz)	Min.	Typ.	Max.	Units
Frequency Range		0.01		26.5	GHz
Gain	0.01		19.9		dB
	5		18.0		
	10		18.0		
	20		16.9		
	26.5		17.3		
Input Return Loss	0.01		16.6		dB
	5		13.3		
	10		20.0		
	20		13.0		
	26.5		20.0		
Output Return Loss	0.01		17.9		dB
	5		15.5		
	10		19.6		
	20		13.0		
	26.5		20.0		
Isolation	0.01-26.5		41.0		dB
Output Power at 1dB Compression (P <sub>1dB</sub> ) <sup>2</sup>	0.01		+20.0		dBm
	5		+18.1		
	10		+18.5		
	20		+15.7		
	26.5		+11.9		
Output Power at 3dB Compression (P <sub>3dB</sub> ) <sup>3</sup>	0.01		+21.8		dBm
	5		+21.2		
	10		+20.6		
	20		+17.2		
	26.5		+14.4		
Output Third-Order Intercept Point (P <sub>OUT</sub> = -2dBm/Tone)	0.01		+28.1		dBm
	5		+26.8		
	10		+27.7		
	20		+25.4		
	26.5		+18.1		
Input Third-Order Intercept Point (P <sub>OUT</sub> = -2dBm/Tone)	0.01		+8.2		dBm
	5		+8.8		
	10		+9.7		
	20		+8.5		
	26.5		+0.8		
Noise Figure	2		7.6		dB
	5		4.3		
	10		3.6		
	20		5.5		
	26.5		7.9		
Additive Phase Noise (@10kHz Offset)			-172		dBc/Hz
Device Operating Voltage (V <sub>CC</sub> )		+4.75	+5	+5.25	V
Device Operating Current (I <sub>CC</sub> ) <sup>4</sup>			85		mA
Control Voltage (V <sub>C</sub> )			+5		V
Control Current (I <sub>C</sub> )			1.2		mA
Base Voltage (V <sub>B</sub> )			+5		V
Base Current (I <sub>B</sub> )			4.5		mA
Device Current Variation vs. Temperature <sup>5</sup>			7		uA/°C
Device Current Variation vs. Voltage <sup>6</sup>			0.013		mA/mV

1. Tested on Mini-Circuits Die Characterization Test Board. See Figure 2. De-embedded to the device reference plane.

2. Defined as Output Power at which Gain is compressed by 1dB.

3. Defined as Output Power at which Gain is compressed by 3dB.

4. Current at P<sub>IN</sub> = -25dBm. Increases to 105mA at P<sub>3dB</sub>

5. ((Current in mA at +105°C) - (Current in mA at -45°C)) / (+150°C)

6. ((Current in mA at +5.25V) - (Current in mA at +4.75V)) / ((+5.25V - +4.75V) \* 1000mA/mV)





MMIC DIE

# Wideband Amplifier

# LVA-273PN-D+

50Ω 0.01 to 26.5GHz Ultra-Low Phase Noise

## TYPICAL PERFORMANCE GRAPHS

Note: All data taken at nominal conditions  $V_{CC} = +5V$ ,  $V_C = +5V$ , and  $V_B = +5V$  unless noted otherwise.

**GAIN vs. TEMPERATURE**  
 $P_{IN} = -25dBm$

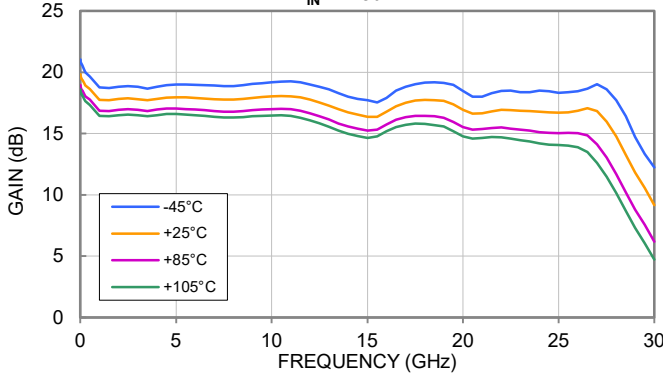

**ISOLATION vs. TEMPERATURE**  
 $P_{IN} = -25dBm$

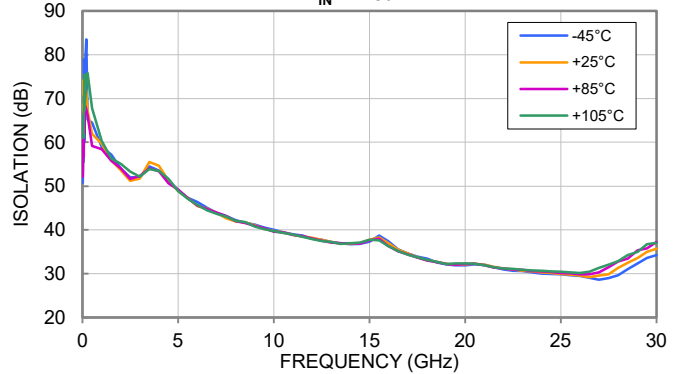

**INPUT RETURN LOSS vs. TEMPERATURE**  
 $P_{IN} = -25dBm$

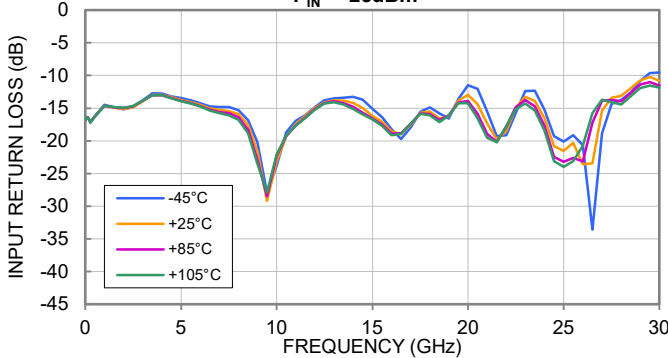

**OUTPUT RETURN LOSS vs. TEMPERATURE**  
 $P_{IN} = -25dBm$

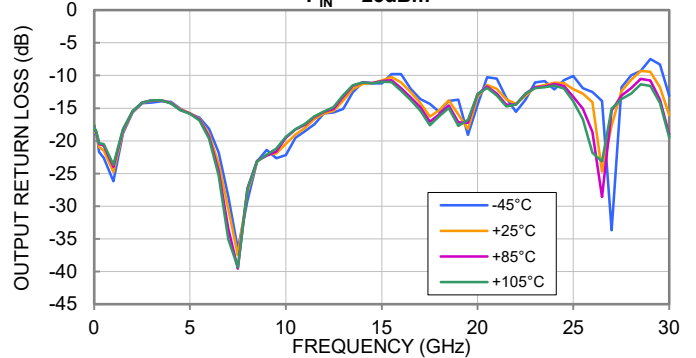

**INPUT IP3 vs. TEMPERATURE**  
 $P_{OUT} = -2dBm/TONE$

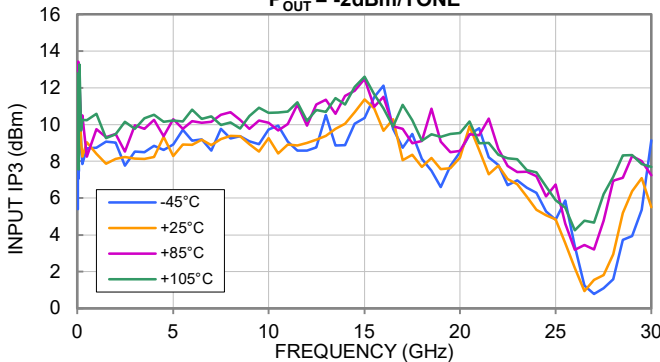

**OUTPUT IP3 vs. TEMPERATURE**  
 $P_{OUT} = -2dBm/TONE$

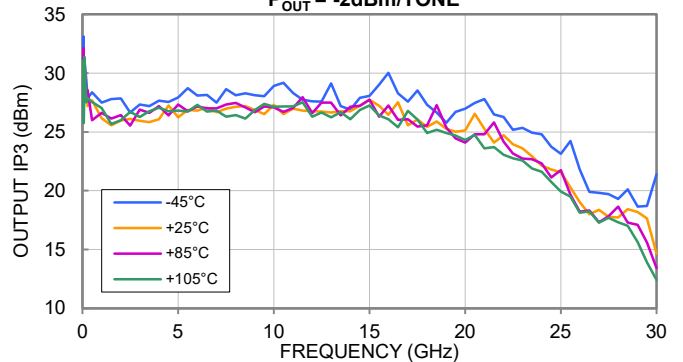



MMIC DIE

# Wideband Amplifier LVA-273PN-D+

50Ω 0.01 to 26.5GHz Ultra-Low Phase Noise

## TYPICAL PERFORMANCE GRAPHS

Note: All data taken at nominal conditions  $V_{CC} = +5V$ ,  $V_C = +5V$ , and  $V_B = +5V$  unless noted otherwise.

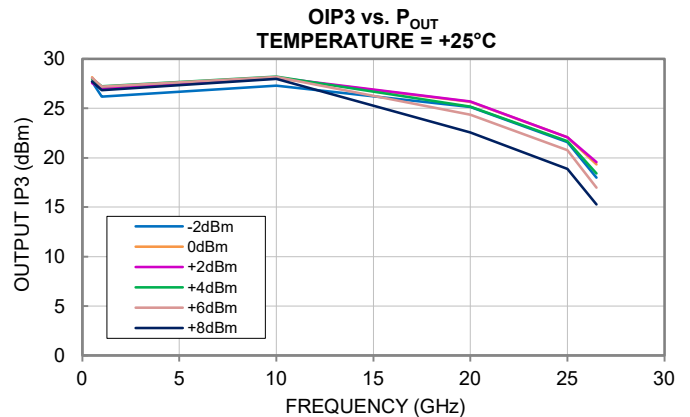
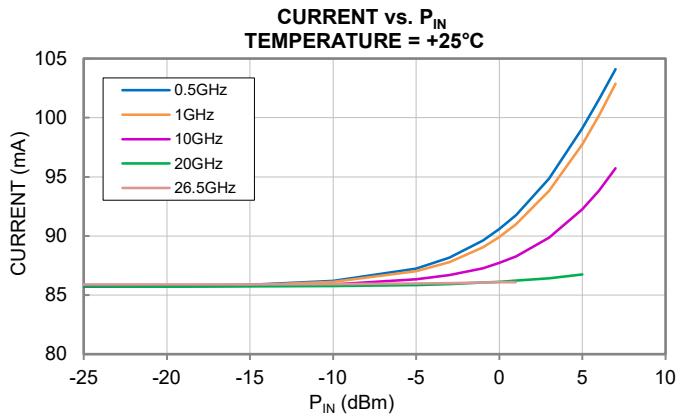
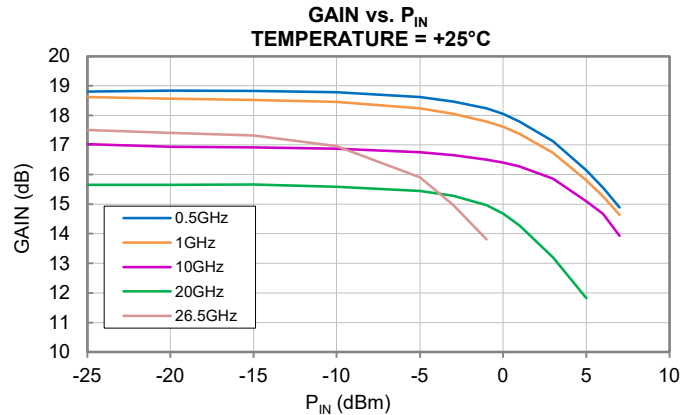
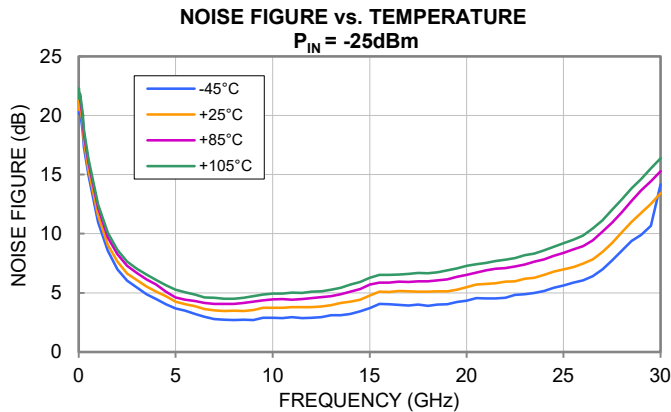
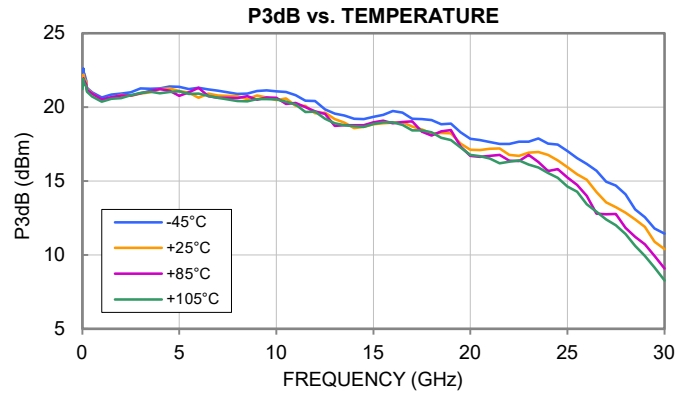
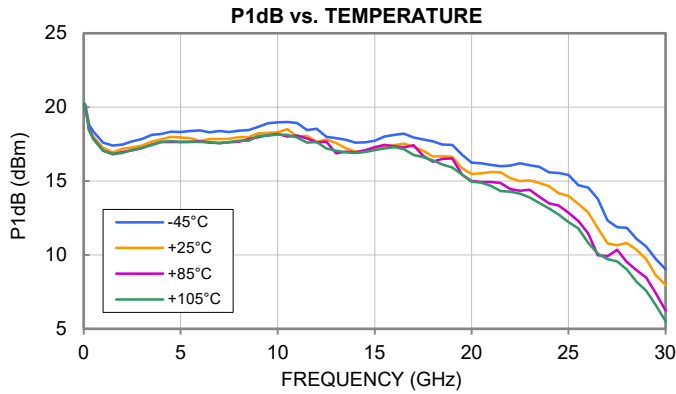



MMIC DIE

# Wideband Amplifier

# LVA-273PN-D+

50Ω 0.01 to 26.5GHz Ultra-Low Phase Noise

## TYPICAL PERFORMANCE GRAPHS

Note: All data taken at nominal conditions  $V_{CC} = +5V$ ,  $V_C = +5V$ , and  $V_B = +5V$  unless noted otherwise.

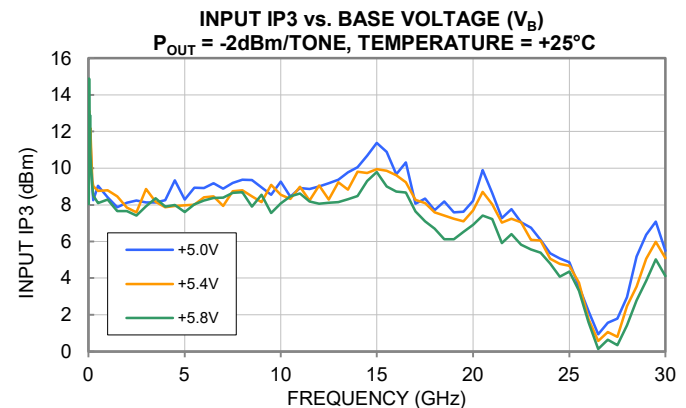
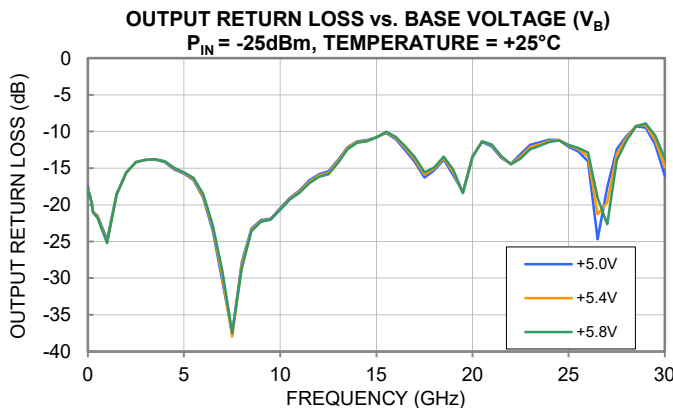
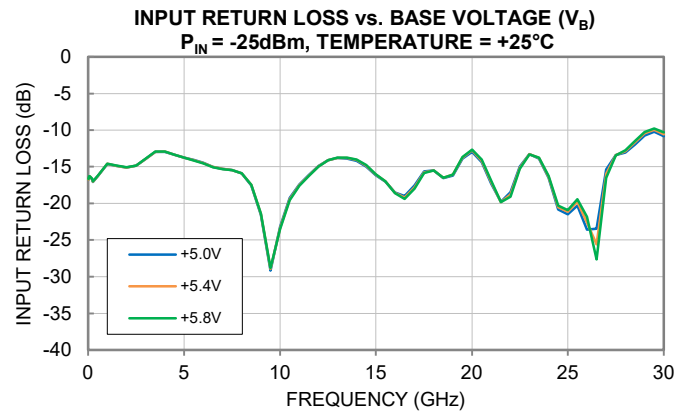
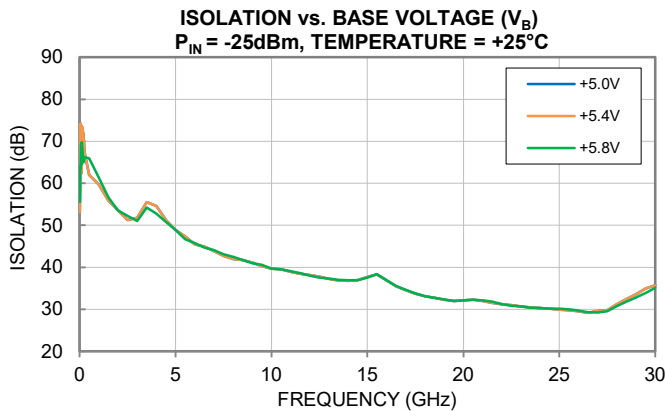
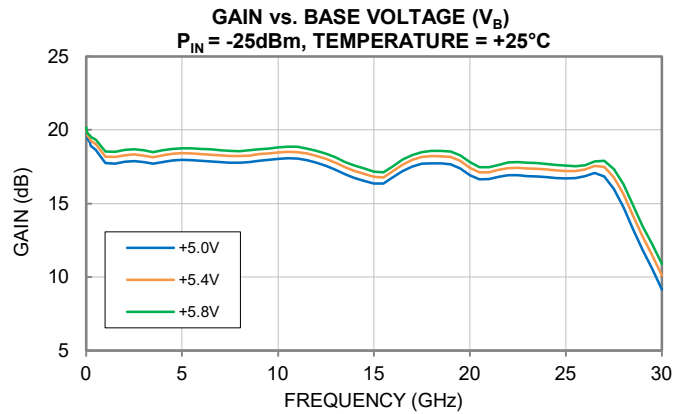
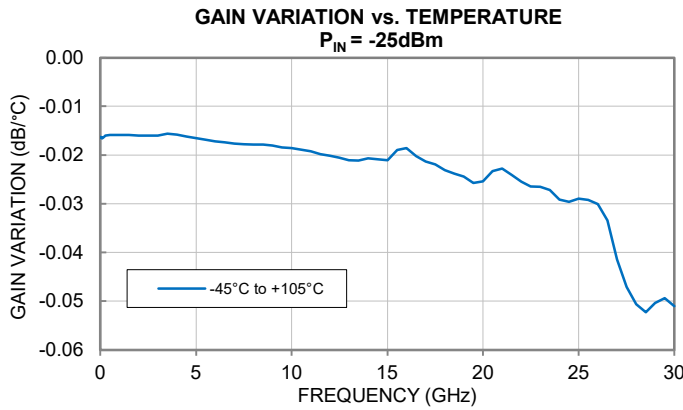



MMIC DIE

# Wideband Amplifier

## LVA-273PN-D+

50Ω 0.01 to 26.5GHz Ultra-Low Phase Noise

### TYPICAL PERFORMANCE GRAPHS

Note: All data taken at nominal conditions  $V_{CC} = +5V$  and  $V_C = +5V$  unless noted otherwise.

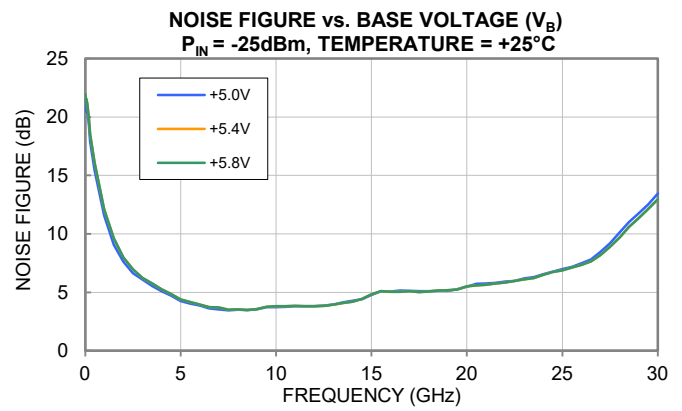
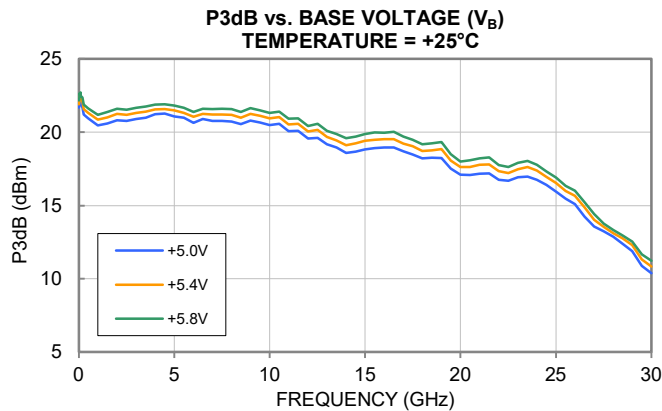
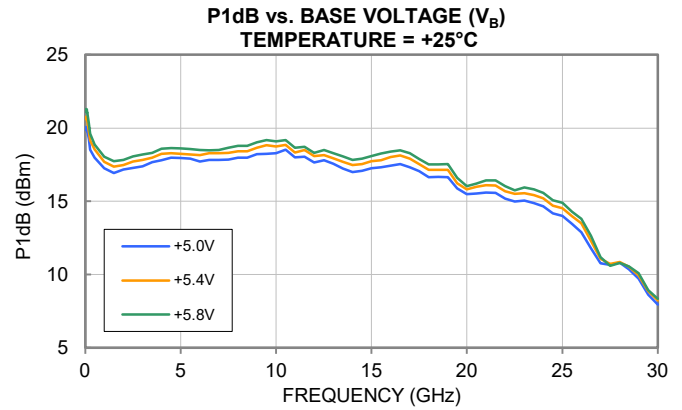
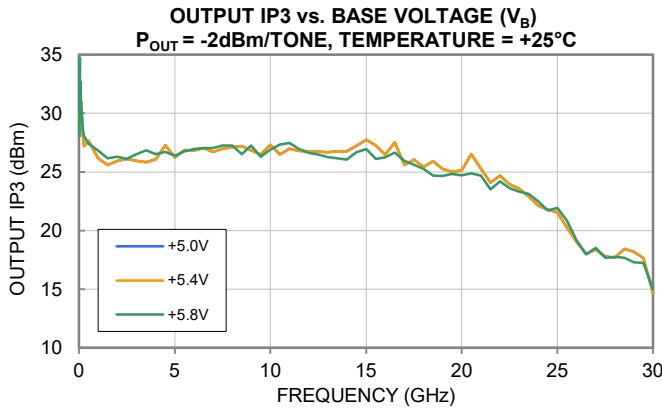



MMIC DIE

# Wideband Amplifier

# LVA-273PN-D+

50Ω 0.01 to 26.5GHz Ultra-Low Phase Noise

## TYPICAL PERFORMANCE GRAPHS

Note: All data taken at nominal conditions  $V_{CC} = +5V$ ,  $V_C = +5V$ , and  $V_B = +5V$  unless noted otherwise.

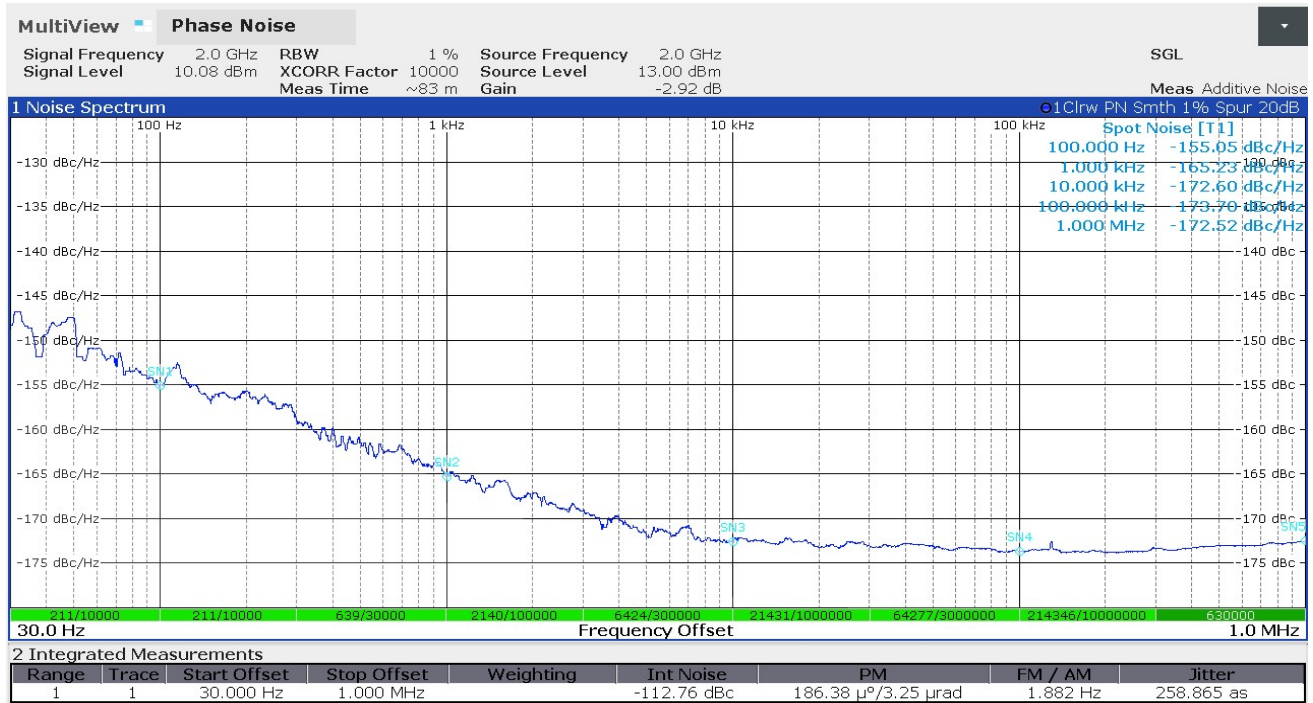

Note: Tested in a 4x4mm 24-lead QFN-style package.





MMIC DIE

# Wideband Amplifier

# LVA-273PN-D+

50Ω 0.01 to 26.5GHz Ultra-Low Phase Noise

## ABSOLUTE MAXIMUM RATINGS<sup>7</sup>

Parameter	Ratings
Operating Temperature (ground lead) <sup>8</sup>	-45°C to +105°C
Storage Temperature <sup>9</sup>	+20°C to +35°C
Total Power Dissipation	1.54W
Junction Temperature <sup>10</sup>	+150°C
Input Power (CW), $V_{CC} = +5V$ , $V_C = +5V$ , $V_B = +5V$	+25dBm
DC Voltage on RF-OUT & $V_{CC}$	+10V
DC Voltage on RF-IN	+10V
Current $I_{CC}$	150mA
DC Voltage on $V_C$	+10V
Current $I_C$	5mA
DC Voltage on $V_B$	+10V
Current $I_B$	14mA

7. Permanent damage may occur if any of these limits are exceeded. Maximum ratings are not intended for continuous normal operation.

8. Bottom of Die.

9. For die shipped in Gel-Pak see ENV80 (limited by packaging)

10. Peak temperature on top of Die.

## THERMAL RESISTANCE

Parameter	Ratings
Thermal Resistance ( $\Theta_{jc}$ ) <sup>11</sup>	29.2°C/W

11.  $\Theta_{jc}$  = (Hot Spot Temperature on Die - Temperature at Ground Lead)/Dissipated Power

## ESD RATING<sup>12</sup>

	Class	Voltage Range	Reference Standard
HBM	1B	500V to < 1000V	ANSI/ESDA/JEDEC JS-001-2017
CDM	C2	500V to < 1000V	JESD22-C101F



ESD HANDLING PRECAUTION: This device is designed to be Class 1B for HBM. Static charges may easily produce potentials higher than this with improper handling and can discharge into DUT and damage it. As a preventive measure Industry standard ESD handling precautions should be used at all times to protect the device from ESD damage.

12. Tested in 4x4mm 24-lead QFN-style package.







MMIC DIE

# Wideband Amplifier **LVA-273PN-D+**

50Ω 0.01 to 26.5GHz Ultra-Low Phase Noise

## FUNCTIONAL DIAGRAM

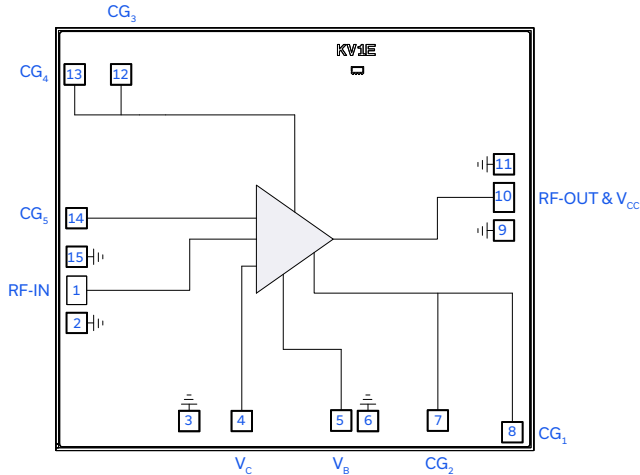
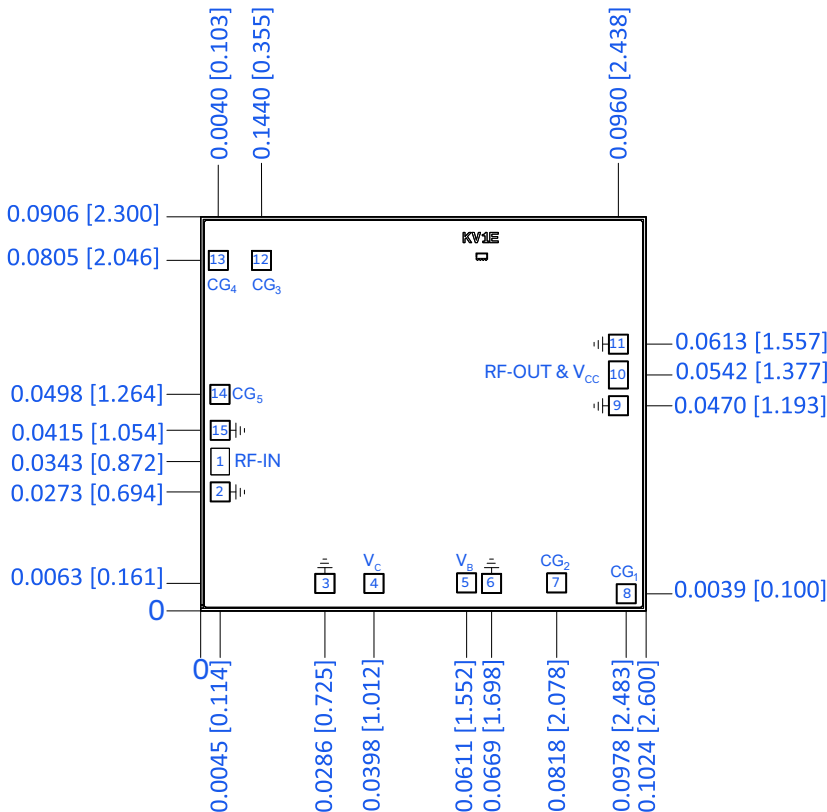

Figure 1. LVA-273PN-D+ Functional Diagram

## PAD DESCRIPTION

Function	Pad #	Application Description (Refer to Figure 2)
RF-IN	1	RF-IN Pad connects to RF-Input port.
RF-OUT & V <sub>CC</sub>	10	RF-OUT Pad connects to RF-Output and V <sub>CC</sub> port.
V <sub>C</sub>	4	DC Input Pad connects to voltage input port, V <sub>C</sub> .
V <sub>B</sub>	5	DC Input Pad connects to voltage input port, V <sub>B</sub> .
CG <sub>1</sub>	8	Connects to AC ground through external capacitor C9.
CG <sub>2</sub>	7	Connects to AC ground through external capacitor C8.
CG <sub>3</sub>	12	Connects to AC ground through external capacitor C3.
CG <sub>4</sub>	13	Connects to AC ground through external capacitor C2.
CG <sub>5</sub>	14	Connects to AC ground through external capacitor C1.
GND	2, 3, 6, 9, 11, 15, & Bottom of Die	Connects to ground.

## DIE OUTLINE: inches [mm], Typical



## DIMENSIONS: inches [mm], Typical

Die Size	0.1024 x 0.0906 [2.600 x 2.300]
Die Thickness	0.0040 [0.100]
Bond Pad Sizes:	
Pad 1 & 10	0.0061 x 0.0061 [0.155 x 0.155]
Pads 2-9, 11-15	0.0043 x 0.0043 [0.108 x 0.108]
Plating (Pads & Bottom of Die)	Gold





MMIC DIE

# Wideband Amplifier

## LVA-273PN-D+

50Ω 0.01 to 26.5GHz Ultra-Low Phase Noise

### CHARACTERIZATION TEST BOARD

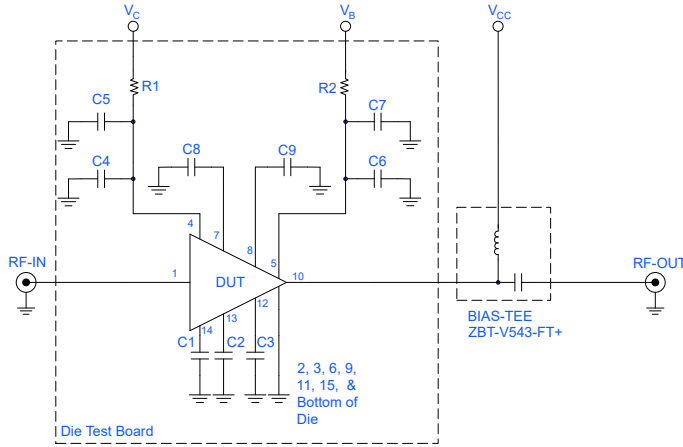

Figure 2. Die Evaluation Board

### Electrical Parameters and Conditions

Gain, Return Loss, Output Power at 1dB Compression (P1dB), Output Power at 3dB Compression (P3dB), Output IP3 (OIP3), and Noise Figure measured using N5247B PNA-X Microwave Network Analyzer.

#### Conditions:

1. Gain, Noise Figure, and Return Loss:  $P_{IN} = -25\text{dBm}$
2. Output IP3 (OIP3): Two tones, spaced 1MHz apart,  $-2\text{dBm}/\text{tone}$  at output.

#### Power On/Power Off Sequence

Caution: Permanent damage to the device will occur if the Power ON and Power OFF Sequences are not followed.

#### Power On:

- 1) Set  $V_{CC} = +5\text{V}$ .
- 2) Set  $V_C = +5\text{V}$ .
- 3) Set  $V_B = +5\text{V}$ .
- 4) Turn on  $V_{CC}$ ,  $V_C$ , and  $V_B$ .
- 5) Apply RF Signal.

#### Power Off:

- 1) Turn off RF Signal.
- 2) Turn off  $V_{CC}$ ,  $V_C$ , and  $V_B$ .

Note: Mini-Circuits Bias Tee ZBT-V543-FT+ is external to the Characterization and Application Circuit.

Component	Value	Size	Part Number	Manufacturer
C1	5100pF	0603	GCM1885C1H512JA16D	Murata
C2	1μF	0603	GCM188R71E105KA64J	Murata
C3, C9	1000pF	0402	GRM1555C1H102JA01D	Murata
C4, C6	100pF	0402	GRM1555C1H101JA01D	Murata
C5, C7, C8	0.1μF	0402	GRM155R71H104KE14J	Murata
R1, R2	0Ω	0402	RK73Z1ETTP	KOA Speer





MMIC DIE

# Wideband Amplifier

## LVA-273PN-D+

50Ω 0.01 to 26.5GHz Ultra-Low Phase Noise

### ASSEMBLY DIAGRAM

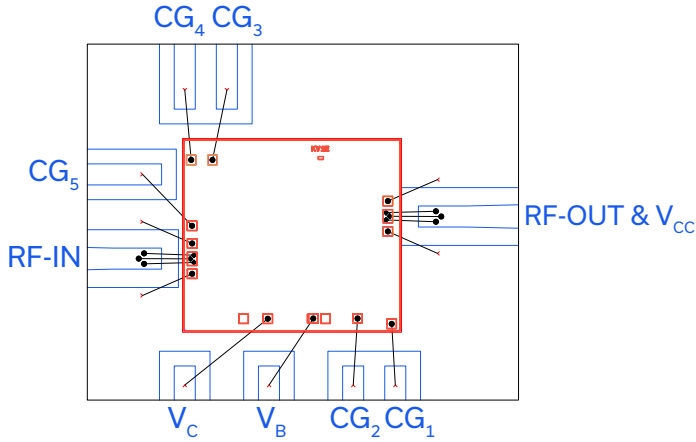



Figure 3. LVA-273PN-D+ Assembly Diagram

Refer to the table in Figure 2 for more details on the passive components.

- Bond wire diameter: 1mil
- Bond wire lengths from Die Pad to PCB at RF-IN & RF-OUT ports:  $24 \pm 2$  mils
- Typical Gap from Die edge to PCB edge: 3mils
- PCB thickness and material: 6.6mil RO4350B (Thickness : 1oz copper on each side).

### ASSEMBLY AND HANDLING PROCEDURE

1. Storage  
Die should be stored in a dry nitrogen purged desiccator or equivalent.
2.  ESD Precautions  
MMIC pHEMT amplifier die are susceptible to electrostatic and mechanical damage. Die are supplied in anti-static protected material, which should be opened only in clean room conditions at an appropriately grounded anti-static workstation.
3. Die Handling and Attachment  
Devices require careful handling using tools appropriate for manipulating semiconductor chips. It is recommended to handle the chips along the edges with a custom designed collet. The surface of the chips have exposed air bridges and should not be touched with a vacuum collet, tweezers or fingers. The die mounting surface must be clean and flat. Using conductive silver-filled epoxy, apply sufficient adhesive to meet the required bond line thickness, fillet height and coverage around the total periphery of the device. The recommended epoxy is Atox 800HT5 Sintering or equivalent. Parts should be cured in a nitrogen-filled atmosphere per manufacturer's recommended cure profile.
4. Wire Bonding  
Openings in the surface passivation above the gold bond pads are provided to allow wire bonding to the die. Thermosonic bonding is recommended with minimized ultrasonic content. Bond force, time, ultrasonic power and temperature are all critical parameters. The suggested interconnect is pure gold, 1 mil diameter wire. Bonds are recommended to be made from the bond pads on the die to the package or substrate. All bond wire length and bond wire height should be kept as short as possible, unless specified by design, to minimize performance degradation due to undesirable series inductance.





MMIC DIE

# Wideband Amplifier

## LVA-273PN-D+

50Ω 0.01 to 26.5GHz Ultra-low Phase Noise

ADDITIONAL DETAILED INFORMATION IS AVAILABLE ON OUR DASH BOARD [CLICK HERE](#)

<b>Performance Data</b>	Table Graphs S-Parameter (S2P Files) Data Set (.zip file)								
<b>Case Style</b>	Die								
<b>RoHs Status</b>	Compliant								
<b>Die Ordering and Packaging Information</b>	<table> <tr> <td>Quantity, Package</td> <td>Model No.</td> </tr> <tr> <td>Gel - Pak: 5, 10, 50, KGD*</td> <td>LVA-273PN-DG+</td> </tr> <tr> <td>Medium<sup>†</sup>, Partial wafer: KGD*&lt;399</td> <td>LVA-273PN-DP+</td> </tr> <tr> <td>Full wafer<sup>†</sup></td> <td>LVA-273PN-DF+</td> </tr> </table> <sup>†</sup> Available upon request contact sales representative. Refer to <a href="#">AN-60-067</a>	Quantity, Package	Model No.	Gel - Pak: 5, 10, 50, KGD*	LVA-273PN-DG+	Medium <sup>†</sup> , Partial wafer: KGD*<399	LVA-273PN-DP+	Full wafer <sup>†</sup>	LVA-273PN-DF+
Quantity, Package	Model No.								
Gel - Pak: 5, 10, 50, KGD*	LVA-273PN-DG+								
Medium <sup>†</sup> , Partial wafer: KGD*<399	LVA-273PN-DP+								
Full wafer <sup>†</sup>	LVA-273PN-DF+								
<b>Die Marking</b>	KV1E								
<b>Environmental Ratings</b>	ENV80								

\* Known Good Die ("KGD") means that the die in question have been subjected to Mini-Circuits DC test performance criteria and measurement instructions and that the parametric data of such die fall within a predefined range. While DC testing is not definitive, it does provide a higher degree of confidence that die are capable of meeting typical RF electrical parameters specified by Mini-Circuits.

Notes

- A. Performance and quality attributes and conditions not expressly stated in this specification document are intended to be excluded and do not form a part of this specification document.
- B. Electrical specifications and performance data contained in this specification document are based on Mini-Circuits' applicable established test performance criteria and measurement instructions.
- C. The parts covered by this specification document are subject to Mini-Circuits' standard limited warranty and terms and conditions (collectively, "Standard Terms"); Purchasers of this part are entitled to the rights and benefits contained there in. For a full statement of the standard. Terms and the exclusive rights and remedies thereunder, please visit Mini-Circuits' website at [www.minicircuits.com/MCLStore/terms.jsp](http://www.minicircuits.com/MCLStore/terms.jsp)
- D. Mini-Circuits does not warrant the accuracy or completeness of the information, text, graphics and other items contained within this document and same are provided as an accommodation and on an As is basis, with all faults.
- E. Purchasers of this part are solely responsible for proper storing, handling, assembly and processing of known good die (KGD) (including, without limitation, proper ESD preventative measures, die preparation, die attach, wire bonding and related assembly and test activities), and Mini-Circuits assumes no responsibility therefor or for environmental effects on KGD.
- F. Mini-Circuits and the Mini-Circuits logo are registered trademarks of Scientific Components Corporation d/b/a Mini-Circuits. All other third-party trademarks are the property of their respective owners. A reference to any third-party trademark does not constitute or imply any endorsement, affiliation, sponsorship, or recommendation by any such third-party of Mini-Circuits or its products.



*Typical Performance Data*

**NOTE: Use PDF Bookmarks to view DATA at required conditions**

**Definitions:**

Input Return Loss = -S11 (dB)

Gain(Power Gain) = S21 (dB)

Reverse Isolation = -S12 (dB)

Output Return Loss = -S22 (dB)

TEST CONDITIONS: V<sub>CC</sub> = +5V, V<sub>B</sub> = +5V, V<sub>C</sub> = +5V, I<sub>CC</sub> = 85mA, I<sub>B</sub> = 4.7mA, I<sub>C</sub> = 1.2mA @ Temperature = +25°C

FREQ	Gain	Isolation	Input Return Loss	Output Return Loss	Stability		IP-3 Input	IP-3 Output	1dB Comp. Output	3dB Comp. Output	Noise Figure
					K	Measure					
(GHz)	(dB)	(dB)	(dB)	(dB)	K	Measure	(dBm)	(dBm)	(dBm)	(dBm)	(dB)
0.01	19.8	53.1	-16.8	-17.5	22.5	1.0	-	-	20.0	21.7	21.4
0.02	19.7	63.2	-16.8	-18.6	72.6	1.0	9.6	29.4	20.0	21.8	20.5
0.03	19.6	64.3	-16.6	-18.7	83.8	1.0	11.9	31.5	19.9	21.8	20.9
0.04	19.6	74.3	-16.5	-18.7	264.3	1.0	10.6	30.2	20.1	22.2	20.9
0.05	19.5	62.7	-16.4	-18.6	70.3	1.0	10.4	30.0	20.1	22.2	20.9
0.06	19.5	67.9	-16.4	-18.5	128.7	1.0	10.0	29.5	20.0	22.1	20.9
0.07	19.5	63.0	-16.4	-18.5	73.2	1.0	10.5	30.0	20.0	22.1	20.8
0.08	19.4	71.7	-16.4	-18.5	198.9	1.0	11.2	30.7	19.9	22.2	20.6
0.09	19.4	62.3	-16.4	-18.6	68.2	1.0	10.0	29.4	19.8	22.0	20.6
0.10	19.4	73.7	-16.4	-18.7	252.8	1.0	11.6	31.0	19.8	21.9	20.5
0.20	19.1	71.7	-16.7	-19.8	208.5	1.0	9.0	28.2	19.3	21.7	19.4
0.25	18.9	67.2	-17.1	-21.0	127.9	1.0	8.3	27.2	18.5	21.2	17.9
0.50	18.6	61.9	-16.3	-21.5	72.1	1.0	9.0	27.7	18.0	20.9	15.4
1.00	17.8	59.7	-14.6	-24.8	61.9	1.0	8.4	26.2	17.3	20.5	11.5
1.50	17.7	55.9	-14.9	-18.5	40.1	1.0	7.9	25.6	16.9	20.6	9.1
2.00	17.8	53.6	-15.1	-15.6	30.4	1.0	8.1	26.0	17.2	20.8	7.6
2.50	17.9	51.2	-14.9	-14.2	22.6	1.0	8.2	26.1	17.3	20.8	6.6
3.00	17.8	51.7	-13.9	-13.9	24.2	1.0	8.1	26.0	17.4	20.9	6.1
3.50	17.7	55.5	-13.0	-13.8	37.7	1.0	8.1	25.8	17.7	21.0	5.5
4.00	17.8	54.6	-12.9	-14.2	34.0	1.0	8.2	26.1	17.8	21.2	5.1
4.50	17.9	51.2	-13.3	-15.1	23.1	1.0	9.3	27.3	18.0	21.3	4.7
5.00	18.0	48.8	-13.8	-15.7	17.7	1.0	8.3	26.3	17.9	21.1	4.3
5.50	17.9	47.3	-14.1	-16.6	15.2	1.0	8.9	26.9	17.9	21.0	4.0
6.00	17.9	45.4	-14.5	-19.0	12.5	1.0	8.9	26.8	17.7	20.6	3.9
6.50	17.9	44.9	-15.0	-23.5	12.0	1.0	9.2	27.1	17.8	20.9	3.6
7.00	17.8	43.9	-15.3	-30.4	10.9	1.0	8.9	26.7	17.8	20.8	3.5
7.50	17.8	42.7	-15.4	-37.5	9.6	1.0	9.2	27.0	17.9	20.8	3.5
8.00	17.8	41.9	-15.9	-27.8	8.9	1.0	9.4	27.1	18.0	20.7	3.5
8.50	17.8	41.7	-17.5	-23.2	8.7	1.0	9.4	27.2	18.0	20.5	3.5
9.00	17.9	41.1	-21.6	-22.1	8.2	1.0	8.9	26.9	18.2	20.8	3.6
9.50	18.0	40.3	-29.2	-21.9	7.5	1.0	8.5	26.5	18.3	20.7	3.7
10.00	18.0	39.7	-23.2	-20.4	7.0	1.0	9.3	27.3	18.3	20.5	3.7
10.50	18.1	39.5	-19.3	-19.0	6.7	1.0	8.4	26.5	18.5	20.6	3.7
11.00	18.1	38.9	-17.4	-18.1	6.2	1.0	8.9	27.0	18.0	20.1	3.8
11.50	17.9	38.5	-16.1	-16.7	6.0	1.0	8.9	26.8	18.1	20.1	3.8
12.00	17.8	38.2	-14.9	-15.8	5.9	1.0	9.0	26.8	17.6	19.6	3.8
12.50	17.6	37.7	-14.1	-15.4	5.7	1.0	9.2	26.7	17.8	19.6	3.9
13.00	17.3	37.2	-13.8	-13.9	5.5	1.0	9.4	26.7	17.6	19.2	3.9
13.50	17.0	36.9	-13.9	-12.1	5.4	1.0	9.8	26.8	17.2	18.9	4.2
14.00	16.7	36.8	-14.2	-11.3	5.5	0.9	10.0	26.8	17.0	18.6	4.3
14.50	16.5	36.9	-15.0	-11.1	5.7	0.9	10.7	27.2	17.1	18.7	4.4
15.00	16.4	37.7	-16.2	-10.8	6.3	0.9	11.4	27.7	17.3	18.8	4.8
15.50	16.4	38.3	-17.0	-10.2	6.8	0.9	10.9	27.2	17.3	18.9	5.1
16.00	16.8	36.9	-18.5	-11.0	5.7	0.9	9.7	26.5	17.4	19.0	5.1
16.50	17.2	35.5	-19.0	-12.5	4.7	0.9	10.3	27.5	17.5	19.0	5.1
17.00	17.5	34.6	-17.5	-14.2	4.2	1.0	8.1	25.6	17.3	18.7	5.1
17.50	17.7	33.7	-15.7	-16.3	3.7	1.0	8.3	26.0	17.0	18.5	5.1
18.00	17.7	33.1	-15.5	-15.3	3.5	1.0	7.7	25.4	16.7	18.2	5.1
18.50	17.7	32.7	-16.6	-13.8	3.3	1.0	8.2	25.9	16.7	18.3	5.1
19.00	17.7	32.3	-16.2	-16.0	3.3	1.0	7.6	25.3	16.6	18.2	5.1
19.50	17.4	32.0	-13.9	-18.2	3.3	1.0	7.6	25.0	15.9	17.5	5.3
20.00	16.9	32.1	-13.0	-13.3	3.4	1.0	8.2	25.1	15.5	17.1	5.5
20.50	16.6	32.3	-14.4	-11.4	3.5	0.9	9.9	26.5	15.5	17.1	5.7
21.00	16.7	32.0	-17.3	-12.0	3.5	0.9	8.6	25.3	15.6	17.2	5.8
21.50	16.8	31.6	-19.8	-13.6	3.3	1.0	7.3	24.1	15.6	17.2	5.8
22.00	16.9	31.2	-18.5	-14.4	3.2	1.0	7.8	24.7	15.2	16.8	5.9
22.50	16.9	31.0	-15.0	-13.1	3.1	1.0	7.0	24.0	15.0	16.7	6.0
23.00	16.9	30.7	-13.3	-11.8	2.9	0.9	6.7	23.6	15.0	16.9	6.2
23.50	16.8	30.5	-13.9	-11.5	2.9	0.9	6.1	22.9	14.9	17.0	6.3
24.00	16.8	30.3	-16.5	-11.1	2.9	0.9	5.4	22.1	14.7	16.8	6.5
24.50	16.7	30.1	-20.8	-11.1	2.9	0.9	5.1	21.8	14.2	16.4	6.8
25.00	16.7	30.0	-21.5	-12.1	2.9	0.9	4.9	21.6	14.0	15.9	7.0
25.50	16.7	29.8	-20.3	-12.7	2.9	0.9	3.5	20.3	13.5	15.5	7.2
26.00	16.9	29.5	-23.6	-14.1	2.8	0.9	2.2	19.0	12.9	15.1	7.5
26.50	17.1	29.2	-23.5	-24.7	2.7	1.0	0.9	18.0	11.8	14.2	7.8
27.00	16.8	29.6	-15.4	-17.6	2.8	1.0	1.6	18.4	10.8	13.6	8.5
27.50	16.0	29.8	-13.4	-12.4	3.0	1.0	1.8	17.8	10.7	13.2	9.2
28.00	14.8	31.3	-13.1	-10.6	4.0	0.9	3.0	17.7	10.8	12.9	10.1
28.50	13.2	32.5	-12.0	-9.3	5.1	0.9	5.2	18.4	10.4	12.4	11.0
29.00	11.8	33.6	-10.7	-9.4	6.7	1.0	6.4	18.2	9.7	11.9	11.8
29.50	10.6	34.9	-10.2	-11.8	9.5	1.0	7.1	17.7	8.6	10.9	12.5
30.00	9.2	35.7	-10.8	-16.1	12.9	1.1	5.5	14.7	8.0	10.4	13.4

*Typical Performance Data*

**NOTE: Use PDF Bookmarks to view DATA at required conditions**

**Definitions:**

Input Return Loss = -S11 (dB)

Gain(Power Gain) = S21 (dB)

Reverse Isolation = -S12 (dB)

Output Return Loss = -S22 (dB)

TEST CONDITIONS: V<sub>CC</sub> = +5V, V<sub>B</sub> = +5.4V, V<sub>C</sub> = +5V, I<sub>CC</sub> = 94mA, I<sub>B</sub> = 5.2mA, I<sub>C</sub> = 1.3mA @ Temperature = +25°C

FREQ	Gain	Isolation	Input Return Loss	Output Return Loss	Stability		IP-3 Input	IP-3 Output	1dB Comp. Output	3dB Comp. Output	Noise Figure
					K	Measure					
(GHz)	(dB)	(dB)	(dB)	(dB)	K	Measure	(dBm)	(dBm)	(dBm)	(dBm)	(dB)
0.01	20.0	53.1	-16.8	-17.7	30.3	1.0	-	-	20.7	21.9	21.6
0.02	19.9	63.2	-16.6	-18.5	34.3	1.0	11.2	31.1	20.7	22.0	20.7
0.03	19.8	64.3	-16.6	-18.6	63.6	1.0	13.1	32.9	20.6	22.1	21.3
0.04	19.7	74.3	-16.4	-18.6	27.7	1.0	11.1	30.9	20.8	22.4	21.2
0.05	19.7	62.7	-16.4	-18.6	124.2	1.0	10.6	30.3	20.8	22.4	21.3
0.06	19.7	67.9	-16.3	-18.5	70.4	1.0	11.4	31.0	20.7	22.3	21.2
0.07	19.6	63.0	-16.4	-18.5	142.4	1.0	10.8	30.4	20.7	22.4	21.2
0.08	19.6	71.7	-16.4	-18.5	69.9	1.0	12.0	31.6	20.7	22.4	21.0
0.09	19.6	62.3	-16.4	-18.6	136.1	1.0	11.6	31.2	20.5	22.3	20.9
0.10	19.6	73.7	-16.3	-18.7	60.5	1.0	12.2	31.8	20.5	22.2	20.9
0.20	19.4	71.7	-16.7	-19.7	1480.8	1.0	9.4	28.8	19.8	22.1	19.6
0.25	19.3	67.2	-17.1	-20.9	39.1	1.0	9.0	28.3	19.2	21.6	18.2
0.50	19.0	61.9	-16.3	-21.6	84.0	1.0	8.8	27.8	18.5	21.3	15.8
1.00	18.2	59.7	-14.6	-25.1	59.8	1.0	8.8	27.0	17.7	20.9	11.8
1.50	18.2	55.9	-14.9	-18.6	44.3	1.0	8.4	26.6	17.4	21.0	9.3
2.00	18.3	53.6	-15.1	-15.6	26.5	1.0	7.9	26.1	17.5	21.2	7.8
2.50	18.3	51.2	-14.9	-14.2	24.9	1.0	7.6	25.9	17.7	21.2	7.0
3.00	18.3	51.7	-13.9	-13.9	21.6	1.0	8.9	27.1	17.8	21.3	6.2
3.50	18.2	55.5	-13.0	-13.8	33.6	1.0	8.2	26.3	18.0	21.4	5.6
4.00	18.3	54.6	-12.9	-14.1	26.4	1.0	7.9	26.1	18.2	21.5	5.1
4.50	18.4	51.2	-13.3	-15.1	23.4	1.0	7.9	26.3	18.3	21.6	4.7
5.00	18.4	48.8	-13.7	-15.6	18.2	1.0	8.0	26.4	18.2	21.5	4.3
5.50	18.4	47.3	-14.1	-16.5	13.8	1.0	8.0	26.4	18.2	21.3	4.1
6.00	18.4	45.4	-14.5	-18.7	12.0	1.0	8.4	26.8	18.1	21.0	3.9
6.50	18.3	44.9	-15.0	-23.0	11.3	1.0	8.5	26.8	18.3	21.3	3.7
7.00	18.3	43.9	-15.3	-29.7	10.4	1.0	7.9	26.2	18.3	21.2	3.5
7.50	18.2	42.7	-15.5	-38.0	9.5	1.0	8.7	27.0	18.3	21.2	3.5
8.00	18.2	41.9	-15.9	-28.2	8.8	1.0	8.8	27.0	18.4	21.2	3.5
8.50	18.3	41.7	-17.5	-23.4	8.4	1.0	8.5	26.7	18.4	21.0	3.5
9.00	18.4	41.1	-21.4	-22.2	7.8	1.0	8.2	26.5	18.7	21.3	3.6
9.50	18.4	40.3	-29.0	-22.0	7.3	1.0	9.1	27.5	18.8	21.1	3.7
10.00	18.5	39.7	-23.4	-20.6	6.9	1.0	8.6	27.0	18.7	20.9	3.8
10.50	18.5	39.5	-19.4	-19.2	6.4	1.0	8.3	26.9	18.8	21.0	3.7
11.00	18.5	38.9	-17.5	-18.2	6.0	1.0	9.0	27.5	18.3	20.5	3.8
11.50	18.4	38.5	-16.2	-16.9	5.7	1.0	8.2	26.6	18.5	20.6	3.8
12.00	18.2	38.2	-15.0	-16.0	5.6	1.0	9.1	27.3	18.1	20.0	3.8
12.50	18.0	37.7	-14.1	-15.6	5.3	1.0	8.3	26.3	18.2	20.2	3.9
13.00	17.8	37.2	-13.8	-14.1	5.2	1.0	9.2	27.0	17.9	19.7	3.9
13.50	17.5	36.9	-13.8	-12.2	5.1	1.0	8.8	26.3	17.7	19.5	4.1
14.00	17.2	36.8	-14.1	-11.4	5.1	1.0	9.8	27.0	17.5	19.1	4.2
14.50	17.0	36.9	-14.9	-11.2	5.4	0.9	9.7	26.8	17.5	19.2	4.4
15.00	16.8	37.7	-16.1	-10.8	6.1	0.9	10.0	26.8	17.7	19.4	4.8
15.50	16.8	38.3	-17.0	-10.1	6.5	0.9	9.9	26.6	17.8	19.5	5.1
16.00	17.2	36.9	-18.6	-10.8	5.4	0.9	9.6	26.8	18.0	19.5	5.1
16.50	17.7	35.5	-19.2	-12.3	4.5	0.9	9.2	26.9	18.1	19.5	5.1
17.00	18.0	34.6	-17.8	-13.8	3.9	1.0	8.3	26.2	17.9	19.2	5.1
17.50	18.2	33.7	-15.8	-15.9	3.5	1.0	8.1	26.3	17.5	19.1	5.1
18.00	18.2	33.1	-15.5	-15.1	3.3	1.0	7.6	25.8	17.1	18.7	5.1
18.50	18.2	32.7	-16.5	-13.6	3.1	1.0	7.4	25.6	17.2	18.8	5.1
19.00	18.2	32.3	-16.1	-15.6	3.1	1.0	7.2	25.4	17.2	18.9	5.2
19.50	17.9	32.0	-13.8	-18.3	3.1	1.0	7.1	25.0	16.2	18.1	5.3
20.00	17.4	32.1	-12.8	-13.4	3.2	1.0	7.7	25.1	15.8	17.6	5.5
20.50	17.1	32.3	-14.2	-11.4	3.3	0.9	8.7	25.8	16.0	17.6	5.7
21.00	17.1	32.0	-17.1	-11.9	3.3	0.9	8.0	25.1	16.1	17.8	5.7
21.50	17.3	31.6	-19.8	-13.5	3.2	0.9	7.0	24.3	16.1	17.8	5.8
22.00	17.4	31.2	-18.8	-14.4	3.0	1.0	7.3	24.7	15.7	17.3	5.9
22.50	17.4	31.0	-15.1	-13.4	2.9	1.0	7.1	24.5	15.5	17.2	6.0
23.00	17.4	30.7	-13.3	-12.1	2.8	0.9	6.1	23.5	15.6	17.5	6.1
23.50	17.4	30.5	-13.8	-11.7	2.7	0.9	6.1	23.4	15.4	17.6	6.3
24.00	17.3	30.3	-16.4	-11.3	2.7	0.9	5.0	22.4	15.2	17.4	6.5
24.50	17.3	30.1	-20.5	-11.1	2.7	0.9	4.8	22.0	14.7	16.9	6.7
25.00	17.2	30.0	-21.1	-11.9	2.7	0.9	4.7	21.9	14.5	16.5	6.9
25.50	17.2	29.8	-19.8	-12.4	2.7	0.9	3.8	21.0	14.0	16.0	7.1
26.00	17.3	29.5	-22.6	-13.4	2.7	0.9	1.8	19.1	13.5	15.7	7.4
26.50	17.6	29.2	-25.6	-21.3	2.6	1.0	0.6	18.1	12.3	14.9	7.7
27.00	17.5	29.6	-16.0	-19.6	2.5	1.0	1.1	18.5	11.1	14.0	8.3
27.50	16.8	29.8	-13.4	-13.0	2.8	1.0	0.8	17.6	10.7	13.5	9.0
28.00	15.7	31.3	-12.9	-10.9	3.5	0.9	2.5	18.1	10.9	13.1	9.9
28.50	14.2	32.5	-11.7	-9.2	4.4	0.9	3.6	17.7	10.5	12.7	10.8
29.00	12.7	33.6	-10.4	-9.1	5.7	1.0	5.0	17.8	9.9	12.3	11.6
29.50	11.5	34.9	-10.0	-11.2	8.0	1.0	6.0	17.5	8.9	11.3	12.4
30.00	10.1	35.7	-10.6	-14.8	10.7	1.1	5.1	15.2	8.2	10.8	13.2

*Typical Performance Data*

**NOTE: Use PDF Bookmarks to view DATA at required conditions**

**Definitions:**

Input Return Loss = -S11 (dB)

Gain(Power Gain) = S21 (dB)

Reverse Isolation = -S12 (dB)

Output Return Loss = -S22 (dB)

TEST CONDITIONS: V<sub>CC</sub> = +5V, V<sub>B</sub> = +5.8V, V<sub>C</sub> = +5V, I<sub>CC</sub> = 104mA, I<sub>B</sub> = 5.7mA, I<sub>C</sub> = 1.4mA @ Temperature = +25°C

FREQ	Gain	Isolation	Input Return Loss	Output Return Loss	Stability		IP-3 Input	IP-3 Output	1dB Comp. Output	3dB Comp. Output	Noise Figure
					K	Measure					
(GHz)	(dB)	(dB)	(dB)	(dB)	K	Measure	(dBm)	(dBm)	(dBm)	(dBm)	(dB)
0.01	20.2	55.6	-16.7	-17.7	28.8	1.0	-	-	21.1	22.2	22.0
0.02	20.0	58.3	-16.6	-18.4	39.9	1.0	8.1	28.0	21.2	22.2	21.1
0.03	19.9	62.4	-16.5	-18.6	64.8	1.0	10.1	30.1	21.1	22.3	21.6
0.04	19.9	64.0	-16.4	-18.6	78.1	1.0	14.9	34.8	21.3	22.6	21.6
0.05	19.8	63.7	-16.3	-18.6	76.2	1.0	10.4	30.3	21.3	22.7	21.6
0.06	19.8	64.5	-16.4	-18.5	83.7	1.0	10.1	29.9	21.2	22.6	21.5
0.07	19.8	69.3	-16.4	-18.5	146.0	1.0	10.9	30.7	21.2	22.6	21.5
0.08	19.8	64.4	-16.4	-18.5	82.7	1.0	12.9	32.7	21.2	22.7	21.3
0.09	19.8	65.9	-16.3	-18.6	98.6	1.0	11.1	30.9	21.0	22.5	21.3
0.10	19.7	69.8	-16.3	-18.7	154.3	1.0	10.8	30.5	21.1	22.5	21.2
0.20	19.6	64.9	-16.6	-19.7	89.9	1.0	9.0	28.7	20.3	22.4	19.9
0.25	19.5	66.2	-17.0	-21.0	105.4	1.0	8.5	28.1	19.6	21.9	18.5
0.50	19.3	66.0	-16.2	-21.8	105.9	1.0	8.1	27.4	18.9	21.6	16.1
1.00	18.5	61.4	-14.6	-25.2	68.7	1.0	8.3	26.8	18.1	21.2	12.1
1.50	18.5	56.6	-14.9	-18.6	39.7	1.0	7.7	26.2	17.7	21.4	9.6
2.00	18.6	53.6	-15.1	-15.6	27.5	1.0	7.7	26.3	17.8	21.6	8.0
2.50	18.7	52.3	-14.8	-14.2	23.3	1.0	7.4	26.1	18.1	21.5	7.0
3.00	18.6	51.0	-13.9	-13.9	20.2	1.0	7.9	26.5	18.2	21.7	6.2
3.50	18.5	54.2	-12.9	-13.8	29.5	1.0	8.4	26.9	18.3	21.7	5.7
4.00	18.6	52.8	-12.9	-14.0	25.0	1.0	7.9	26.5	18.6	21.9	5.3
4.50	18.7	50.8	-13.3	-15.0	20.1	1.0	8.0	26.7	18.6	21.9	4.9
5.00	18.8	48.9	-13.7	-15.5	16.2	1.0	7.6	26.4	18.6	21.8	4.4
5.50	18.8	46.7	-14.1	-16.3	12.9	1.0	8.0	26.8	18.6	21.7	4.2
6.00	18.7	45.7	-14.5	-18.5	11.8	1.0	8.2	27.0	18.5	21.4	4.0
6.50	18.7	44.7	-15.0	-22.7	10.7	1.0	8.4	27.1	18.5	21.6	3.7
7.00	18.6	44.1	-15.3	-29.0	10.1	1.0	8.4	27.0	18.5	21.6	3.7
7.50	18.6	43.1	-15.5	-37.5	9.2	1.0	8.7	27.3	18.7	21.6	3.5
8.00	18.6	42.5	-15.9	-28.7	8.7	1.0	8.7	27.3	18.8	21.6	3.6
8.50	18.6	41.7	-17.5	-23.6	8.0	1.0	7.9	26.5	18.8	21.4	3.5
9.00	18.7	40.9	-21.4	-22.3	7.4	1.0	8.6	27.2	19.0	21.7	3.6
9.50	18.7	40.6	-28.8	-22.0	7.1	1.0	7.6	26.3	19.2	21.5	3.7
10.00	18.8	39.7	-23.5	-20.7	6.4	1.0	8.1	26.9	19.1	21.3	3.8
10.50	18.9	39.5	-19.6	-19.3	6.2	1.0	8.5	27.3	19.2	21.4	3.8
11.00	18.9	39.1	-17.6	-18.4	5.8	1.0	8.6	27.5	18.7	20.9	3.9
11.50	18.7	38.6	-16.2	-17.0	5.6	1.0	8.2	26.9	18.7	21.0	3.8
12.00	18.6	38.0	-15.0	-16.2	5.2	1.0	8.1	26.6	18.3	20.4	3.8
12.50	18.4	37.6	-14.1	-15.8	5.1	1.0	8.1	26.5	18.5	20.6	3.9
13.00	18.1	37.3	-13.7	-14.3	5.0	1.0	8.2	26.3	18.3	20.1	3.9
13.50	17.8	37.0	-13.8	-12.4	5.0	1.0	8.3	26.2	18.1	19.9	4.1
14.00	17.6	36.9	-14.0	-11.5	5.0	1.0	8.5	26.1	17.8	19.6	4.2
14.50	17.4	37.0	-14.8	-11.3	5.2	0.9	9.3	26.7	17.9	19.7	4.5
15.00	17.2	37.6	-16.0	-10.8	5.7	0.9	9.8	27.0	18.1	19.9	4.8
15.50	17.1	38.4	-17.0	-10.1	6.2	0.9	9.0	26.1	18.3	20.0	5.1
16.00	17.5	36.9	-18.6	-10.7	5.2	0.9	8.7	26.3	18.4	20.0	5.0
16.50	18.0	35.6	-19.4	-12.0	4.3	0.9	8.7	26.7	18.5	20.0	5.1
17.00	18.3	34.6	-18.0	-13.5	3.8	1.0	7.7	25.9	18.3	19.7	5.1
17.50	18.5	33.8	-15.9	-15.6	3.4	1.0	7.1	25.6	17.9	19.5	5.0
18.00	18.6	33.1	-15.5	-14.9	3.1	1.0	6.7	25.3	17.5	19.2	5.1
18.50	18.6	32.7	-16.5	-13.4	3.0	1.0	6.1	24.7	17.5	19.3	5.1
19.00	18.5	32.4	-16.1	-15.2	3.0	1.0	6.1	24.7	17.5	19.3	5.2
19.50	18.3	32.0	-13.7	-18.4	3.0	1.0	6.5	24.8	16.6	18.5	5.2
20.00	17.8	32.2	-12.7	-13.5	3.1	1.0	6.9	24.7	16.0	18.0	5.5
20.50	17.5	32.3	-14.0	-11.3	3.2	0.9	7.4	24.9	16.2	18.1	5.6
21.00	17.5	32.2	-16.9	-11.7	3.2	0.9	7.2	24.7	16.4	18.2	5.6
21.50	17.6	31.8	-19.8	-13.3	3.1	0.9	5.9	23.5	16.4	18.3	5.8
22.00	17.8	31.2	-19.1	-14.5	2.9	1.0	6.4	24.2	16.0	17.8	5.9
22.50	17.8	30.9	-15.3	-13.7	2.8	1.0	5.8	23.6	15.7	17.6	6.0
23.00	17.8	30.7	-13.3	-12.4	2.7	0.9	5.6	23.3	15.9	17.9	6.1
23.50	17.7	30.4	-13.8	-11.9	2.6	0.9	5.4	23.1	15.8	18.0	6.2
24.00	17.7	30.3	-16.3	-11.4	2.6	0.9	4.8	22.5	15.6	17.8	6.5
24.50	17.6	30.1	-20.3	-11.2	2.6	0.9	4.1	21.7	15.1	17.3	6.7
25.00	17.6	30.1	-20.9	-11.8	2.7	0.9	4.4	21.9	14.9	16.9	6.9
25.50	17.5	30.0	-19.4	-12.3	2.7	0.9	3.3	20.8	14.3	16.4	7.1
26.00	17.6	29.8	-21.8	-12.9	2.6	0.9	1.6	19.2	13.8	16.0	7.3
26.50	17.9	29.3	-27.6	-19.1	2.5	1.0	0.1	18.0	12.6	15.2	7.6
27.00	17.9	29.3	-16.5	-22.6	2.5	1.0	0.6	18.5	11.2	14.4	8.2
27.50	17.3	29.5	-13.5	-13.9	2.6	1.0	0.4	17.7	10.6	13.8	8.9
28.00	16.3	30.8	-12.7	-11.3	3.2	0.9	1.4	17.8	10.8	13.3	9.7
28.50	14.9	31.8	-11.5	-9.3	3.9	0.9	2.8	17.7	10.6	12.9	10.6
29.00	13.5	32.8	-10.3	-8.9	5.0	0.9	3.8	17.3	10.1	12.5	11.3
29.50	12.2	33.9	-9.8	-10.6	6.7	1.0	5.0	17.2	8.9	11.7	12.2
30.00	10.9	35.1	-10.3	-13.7	9.6	1.0	4.1	15.0	8.4	11.2	13.0

*Typical Performance Data*

**NOTE: Use PDF Bookmarks to view DATA at required conditions**

**Definitions:**

Input Return Loss = -S11 (dB)

Gain(Power Gain) = S21 (dB)

Reverse Isolation = -S12 (dB)

Output Return Loss = -S22 (dB)

TEST CONDITIONS:  $V_{CC} = +5V$ ,  $V_B = +5V$ ,  $V_C = +5V$ ,  $I_{CC} = 85mA$ ,  $I_B = 4.5mA$ ,  $I_C = 1.2mA$  @ Temperature =  $-45^{\circ}C$

FREQ	Gain	Isolation	Input Return Loss	Output Return Loss	Stability		IP-3 Input	IP-3 Output	1dB Comp. Output	3dB Comp. Output	Noise Figure
					K	Measure					
(GHz)	(dB)	(dB)	(dB)	(dB)	K	Measure	(dBm)	(dBm)	(dBm)	(dBm)	(dB)
0.01	21.0	50.8	-16.8	-17.8	15.1	1.0	-	-	20.0	21.8	21.4
0.02	20.9	57.1	-16.7	-18.6	31.5	1.0	5.4	26.3	20.0	22.0	20.1
0.03	20.8	55.4	-16.5	-18.9	26.3	1.0	9.1	29.9	20.2	22.2	20.3
0.04	20.8	62.6	-16.4	-18.9	60.0	1.0	12.4	33.1	20.2	22.5	20.3
0.05	20.7	62.7	-16.4	-18.8	61.0	1.0	7.0	27.7	20.2	22.6	20.3
0.06	20.7	60.6	-16.4	-18.7	48.3	1.0	8.7	29.4	20.2	22.4	20.3
0.07	20.6	59.9	-16.4	-18.7	44.8	1.0	7.4	28.1	20.0	22.3	20.3
0.08	20.6	79.0	-16.4	-18.7	404.4	1.0	8.2	28.8	20.1	22.4	20.0
0.09	20.6	60.5	-16.4	-18.7	48.4	1.0	8.5	29.1	20.0	22.3	20.0
0.10	20.6	74.2	-16.4	-18.8	234.4	1.0	10.7	31.2	20.0	22.2	20.0
0.20	20.2	83.5	-16.7	-20.0	713.2	1.0	9.1	29.4	19.4	21.8	18.7
0.25	20.0	65.2	-17.0	-21.6	89.4	1.0	7.9	27.9	18.8	21.3	17.3
0.50	19.7	64.5	-16.3	-22.6	86.1	1.0	8.7	28.4	18.3	21.0	15.0
1.00	18.8	59.0	-14.5	-26.2	50.5	1.0	8.8	27.5	17.6	20.6	11.0
1.50	18.7	57.2	-14.9	-18.9	41.6	1.0	9.1	27.8	17.4	20.8	8.6
2.00	18.8	54.0	-15.1	-15.7	28.2	1.0	9.0	27.9	17.5	20.9	7.0
2.50	18.9	52.0	-14.9	-14.2	22.2	1.0	7.8	26.7	17.7	21.0	6.0
3.00	18.8	52.1	-13.8	-14.1	22.4	1.0	8.5	27.3	17.8	21.3	5.5
3.50	18.7	54.5	-12.7	-14.0	29.9	1.0	8.5	27.2	18.1	21.3	4.9
4.00	18.8	53.6	-12.7	-14.0	26.7	1.0	8.8	27.6	18.2	21.3	4.5
4.50	18.9	51.4	-13.2	-15.0	20.8	1.0	8.6	27.6	18.3	21.4	4.0
5.00	19.0	49.0	-13.5	-15.9	16.0	1.0	8.9	27.9	18.3	21.4	3.7
5.50	19.0	47.3	-13.8	-16.5	13.3	1.0	9.7	28.7	18.4	21.2	3.5
6.00	19.0	46.4	-14.3	-18.1	12.3	1.0	9.1	28.1	18.4	21.3	3.2
6.50	19.0	45.0	-14.8	-21.8	10.7	1.0	9.2	28.1	18.3	21.2	3.0
7.00	18.9	43.9	-14.8	-28.5	9.5	1.0	8.6	27.5	18.4	21.1	2.8
7.50	18.9	43.2	-14.8	-36.6	8.9	1.0	9.8	28.7	18.3	21.0	2.7
8.00	18.9	42.2	-15.3	-29.1	8.0	1.0	9.2	28.1	18.4	20.9	2.7
8.50	18.9	41.7	-16.9	-23.2	7.5	1.0	9.4	28.3	18.4	20.9	2.7
9.00	19.0	41.2	-20.2	-21.4	7.2	1.0	9.1	28.1	18.7	21.1	2.7
9.50	19.1	40.6	-27.9	-22.7	6.7	1.0	8.9	28.1	18.9	21.1	2.9
10.00	19.2	40.0	-23.9	-22.2	6.2	1.0	9.7	28.9	19.0	21.1	2.9
10.50	19.2	39.4	-18.7	-19.5	5.8	1.0	9.9	29.2	19.0	21.0	2.9
11.00	19.3	39.0	-16.9	-18.5	5.5	1.0	9.1	28.3	18.9	20.8	2.9
11.50	19.2	38.8	-16.1	-17.5	5.3	1.0	8.6	27.8	18.4	20.4	2.9
12.00	19.0	38.0	-14.9	-15.8	4.9	1.0	8.6	27.6	18.5	20.4	2.9
12.50	18.8	37.7	-13.8	-15.6	4.9	1.0	8.8	27.6	18.0	19.9	2.9
13.00	18.6	37.2	-13.5	-15.1	4.7	1.0	10.5	29.1	17.9	19.6	3.1
13.50	18.3	36.9	-13.4	-12.6	4.6	1.0	8.9	27.2	17.8	19.4	3.1
14.00	18.0	36.7	-13.3	-11.1	4.6	0.9	8.9	26.9	17.6	19.2	3.2
14.50	17.8	36.8	-13.7	-11.2	4.7	0.9	10.1	27.9	17.6	19.2	3.4
15.00	17.7	37.3	-15.1	-11.2	5.1	0.9	10.4	28.1	17.7	19.3	3.7
15.50	17.5	38.7	-16.4	-9.7	6.0	0.9	11.5	29.0	18.0	19.5	4.1
16.00	17.9	37.4	-18.2	-9.8	5.0	0.9	12.1	30.0	18.1	19.7	4.0
16.50	18.5	35.6	-19.8	-12.0	4.0	0.9	9.8	28.3	18.2	19.6	4.0
17.00	18.8	34.6	-17.9	-13.6	3.5	1.0	8.7	27.6	17.9	19.2	3.9
17.50	19.0	33.9	-15.5	-14.4	3.2	1.0	9.5	28.5	17.8	19.2	4.0
18.00	19.2	33.4	-14.9	-15.5	3.0	1.0	8.1	27.3	17.7	19.1	3.9
18.50	19.2	32.5	-15.8	-13.9	2.7	1.0	7.5	26.7	17.5	18.8	4.0
19.00	19.1	32.2	-16.6	-13.7	2.6	1.0	6.6	25.8	17.5	18.9	4.1
19.50	19.0	31.9	-13.6	-19.1	2.7	1.0	7.8	26.7	16.8	18.3	4.2
20.00	18.5	31.9	-11.5	-14.5	2.7	1.0	8.5	27.0	16.2	17.9	4.3
20.50	18.0	32.2	-12.0	-10.3	2.8	0.9	9.5	27.5	16.2	17.8	4.5
21.00	18.0	32.0	-15.5	-10.5	2.8	0.9	9.8	27.8	16.1	17.6	4.5
21.50	18.3	31.5	-19.3	-13.4	2.7	0.9	8.2	26.5	16.0	17.5	4.5
22.00	18.5	31.0	-19.1	-15.6	2.6	1.0	7.8	26.3	16.0	17.5	4.6
22.50	18.5	30.7	-15.8	-13.7	2.5	0.9	6.7	25.2	16.2	17.7	4.8
23.00	18.4	30.6	-12.4	-11.0	2.4	0.9	7.0	25.4	16.1	17.7	4.9
23.50	18.4	30.3	-12.3	-10.8	2.3	0.9	6.6	24.9	16.0	17.9	5.0
24.00	18.5	30.0	-15.2	-12.1	2.3	0.9	6.3	24.8	15.6	17.5	5.2
24.50	18.5	29.9	-19.3	-10.7	2.3	0.9	5.3	23.7	15.5	17.5	5.4
25.00	18.3	29.8	-20.1	-10.1	2.3	0.9	4.8	23.1	15.4	17.0	5.6
25.50	18.4	29.6	-19.1	-11.9	2.3	0.9	5.9	24.2	14.7	16.6	5.9
26.00	18.4	29.5	-20.6	-12.5	2.3	0.9	3.4	21.8	14.6	16.2	6.1
26.50	18.7	29.1	-33.6	-13.9	2.2	0.9	1.2	19.9	13.8	15.7	6.4
27.00	19.0	28.6	-18.9	-33.7	2.0	0.9	0.8	19.8	12.3	15.0	7.0
27.50	18.6	28.9	-14.3	-11.8	2.0	0.9	1.1	19.7	11.9	14.7	7.7
28.00	17.7	29.6	-13.7	-10.0	2.3	0.9	1.6	19.3	11.8	14.1	8.6
28.50	16.4	31.0	-12.6	-9.3	3.0	0.9	3.7	20.1	11.1	13.1	9.4
29.00	14.7	32.4	-10.9	-7.5	3.8	0.9	3.9	18.7	10.6	12.5	9.9
29.50	13.4	33.6	-9.6	-8.3	5.2	0.9	5.4	18.7	9.7	11.8	10.7
30.00	12.2	34.2	-9.5	-13.1	7.0	1.1	9.2	21.4	9.0	11.4	14.2



Typical Performance Data

NOTE: Use PDF Bookmarks to view DATA at required conditions

Definitions:

- Input Return Loss = -S11 (dB)
- Gain(Power Gain) = S21 (dB)
- Reverse Isolation = -S12 (dB)
- Output Return Loss = -S22 (dB)

TEST CONDITIONS: V<sub>CC</sub> = +5V, V<sub>B</sub> = +5.4V, V<sub>C</sub> = +5V, I<sub>CC</sub> = 95mA, I<sub>B</sub> = 5.1mA, I<sub>C</sub> = 1.2mA @ Temperature = -45°C

FREQ	Gain	Isolation	Input Return Loss	Output Return Loss	Stability		IP-3 Input	IP-3 Output	1dB Comp. Output	3dB Comp. Output	Noise Figure
					K	Measure					
(GHz)	(dB)	(dB)	(dB)	(dB)	K	Measure	(dBm)	(dBm)	(dBm)	(dBm)	(dB)
0.01	21.2	54.8	-16.6	-18.0	23.6	1.0	-	-	20.7	22.1	21.8
0.02	21.0	56.8	-16.6	-18.8	29.9	1.0	6.6	27.6	20.8	22.2	20.5
0.03	21.0	58.7	-16.6	-18.8	37.5	1.0	9.8	30.8	20.9	22.4	20.7
0.04	20.9	62.9	-16.4	-18.9	61.3	1.0	4.9	25.8	21.0	22.8	20.7
0.05	20.9	65.1	-16.4	-18.7	78.7	1.0	10.5	31.4	21.0	22.8	20.7
0.06	20.8	62.6	-16.4	-18.7	59.8	1.0	9.6	30.4	20.9	22.7	20.6
0.07	20.8	72.6	-16.4	-18.6	187.8	1.0	9.2	30.0	20.8	22.6	20.6
0.08	20.8	71.4	-16.4	-18.6	165.6	1.0	11.2	32.0	20.7	22.7	20.4
0.09	20.8	63.3	-16.4	-18.7	65.2	1.0	11.4	32.2	20.8	22.6	20.3
0.10	20.8	66.9	-16.4	-18.8	98.2	1.0	9.7	30.5	20.6	22.5	20.4
0.20	20.5	69.2	-16.7	-20.0	133.3	1.0	9.6	30.2	20.0	22.1	19.0
0.25	20.3	78.8	-17.0	-21.6	415.1	1.0	7.4	27.7	19.3	21.8	17.6
0.50	20.1	67.2	-16.2	-22.7	112.2	1.0	8.8	28.9	18.7	21.4	15.2
1.00	19.2	59.5	-14.5	-26.5	51.1	1.0	9.1	28.3	18.0	20.9	11.2
1.50	19.2	55.7	-14.9	-18.9	33.1	1.0	8.4	27.6	17.8	21.2	8.8
2.00	19.3	52.9	-15.2	-15.7	23.7	1.0	7.8	27.1	17.9	21.2	7.2
2.50	19.3	52.1	-14.9	-14.2	21.1	1.0	7.8	27.2	18.1	21.4	6.2
3.00	19.3	51.6	-13.8	-14.1	20.2	1.0	8.7	28.0	18.3	21.6	5.5
3.50	19.1	54.7	-12.7	-13.9	28.9	1.0	8.7	27.9	18.6	21.6	5.0
4.00	19.3	54.7	-12.7	-14.0	28.9	1.0	8.8	28.1	18.6	21.7	4.6
4.50	19.4	51.1	-13.2	-14.9	19.0	1.0	8.5	27.9	18.8	21.7	4.1
5.00	19.5	48.9	-13.5	-15.7	15.0	1.0	9.2	28.7	18.8	21.7	3.8
5.50	19.5	47.1	-13.8	-16.3	12.3	1.0	8.9	28.4	18.7	21.5	3.5
6.00	19.4	45.6	-14.3	-17.9	10.6	1.0	8.9	28.4	18.9	21.7	3.3
6.50	19.4	44.7	-14.8	-21.4	9.8	1.0	8.4	27.8	18.8	21.6	3.0
7.00	19.4	43.9	-14.8	-27.9	9.0	1.0	8.9	28.3	18.8	21.5	2.9
7.50	19.3	43.5	-14.8	-35.9	8.7	1.0	9.4	28.7	18.8	21.4	2.7
8.00	19.3	42.6	-15.3	-29.6	7.9	1.0	8.6	28.0	18.9	21.3	2.7
8.50	19.4	41.8	-16.8	-23.4	7.3	1.0	8.0	27.4	18.9	21.3	2.7
9.00	19.5	41.2	-20.0	-21.4	6.8	1.0	9.3	28.7	19.3	21.5	2.8
9.50	19.6	40.5	-27.5	-22.7	6.3	1.0	9.2	28.8	19.3	21.6	2.9
10.00	19.6	40.0	-24.2	-22.3	6.0	1.0	8.8	28.5	19.4	21.6	2.9
10.50	19.7	39.2	-18.9	-19.7	5.4	1.0	9.1	28.7	19.4	21.5	2.9
11.00	19.7	39.1	-17.1	-18.7	5.2	1.0	9.0	28.7	19.4	21.3	2.9
11.50	19.6	38.7	-16.2	-17.7	5.0	1.0	8.0	27.7	18.9	20.9	2.9
12.00	19.5	37.9	-14.9	-16.0	4.7	1.0	8.2	27.7	19.0	20.9	2.9
12.50	19.3	37.7	-13.8	-15.8	4.6	1.0	9.2	28.5	18.4	20.3	2.9
13.00	19.1	37.3	-13.5	-15.4	4.5	1.0	9.4	28.5	18.4	20.0	3.0
13.50	18.8	37.0	-13.3	-12.8	4.4	1.0	9.0	27.8	18.3	19.9	3.1
14.00	18.5	36.8	-13.1	-11.2	4.4	0.9	8.5	27.0	18.1	19.7	3.2
14.50	18.3	36.7	-13.5	-11.3	4.4	0.9	10.7	29.0	18.2	19.7	3.4
15.00	18.2	37.4	-15.0	-11.2	4.9	0.9	11.0	29.1	18.3	19.9	3.7
15.50	18.0	38.8	-16.3	-9.7	5.8	0.9	10.4	28.4	18.6	20.1	4.0
16.00	18.3	37.4	-18.2	-9.6	4.8	0.9	10.1	28.4	18.7	20.3	4.0
16.50	18.9	35.8	-20.0	-11.7	3.9	0.9	9.8	28.7	18.8	20.2	4.0
17.00	19.3	34.6	-18.3	-13.3	3.4	1.0	8.0	27.3	18.5	19.8	4.0
17.50	19.5	34.0	-15.7	-14.0	3.0	1.0	9.1	28.6	18.4	19.7	4.0
18.00	19.6	33.2	-14.9	-15.2	2.8	1.0	8.3	27.9	18.3	19.6	3.9
18.50	19.7	32.5	-15.7	-13.7	2.6	1.0	7.6	27.3	18.0	19.4	4.0
19.00	19.6	32.1	-16.5	-13.3	2.5	0.9	8.3	27.9	18.0	19.5	4.0
19.50	19.5	31.9	-13.5	-18.5	2.5	1.0	7.0	26.5	17.3	18.9	4.2
20.00	19.0	31.9	-11.3	-14.7	2.6	1.0	6.8	25.8	16.7	18.4	4.4
20.50	18.5	32.0	-11.8	-10.2	2.6	0.9	8.8	27.3	16.7	18.3	4.5
21.00	18.5	32.2	-15.2	-10.3	2.7	0.9	8.4	26.8	16.5	18.2	4.5
21.50	18.7	31.5	-19.2	-13.3	2.6	0.9	7.9	26.6	16.5	18.1	4.6
22.00	18.9	31.0	-19.4	-15.5	2.5	0.9	7.0	26.0	16.6	18.1	4.6
22.50	19.0	30.8	-16.1	-13.9	2.4	0.9	7.4	26.4	16.8	18.3	4.7
23.00	18.9	30.6	-12.4	-11.3	2.3	0.9	7.3	26.1	16.7	18.3	4.9
23.50	18.9	30.3	-12.3	-11.1	2.2	0.9	5.5	24.4	16.6	18.5	5.0
24.00	19.0	30.0	-15.1	-12.4	2.2	0.9	5.7	24.7	16.2	18.1	5.1
24.50	19.0	29.8	-19.1	-10.9	2.2	0.9	4.8	23.8	16.2	18.0	5.3
25.00	18.8	29.9	-19.8	-10.0	2.2	0.8	4.5	23.3	16.1	17.5	5.5
25.50	18.8	29.7	-18.8	-11.7	2.2	0.9	8.1	26.9	15.2	17.0	5.9
26.00	18.9	29.5	-20.0	-12.3	2.2	0.9	3.6	22.4	15.2	16.7	6.0
26.50	19.0	29.2	-28.9	-13.0	2.1	0.9	1.2	20.3	14.4	16.3	6.3
27.00	19.5	28.6	-19.9	-32.0	2.0	0.9	0.7	20.2	12.9	15.5	6.9
27.50	19.3	29.0	-14.5	-12.9	1.9	0.9	0.8	20.0	12.3	15.1	7.6
28.00	18.5	29.6	-13.7	-10.3	2.1	0.9	0.7	19.2	12.1	14.5	8.3
28.50	17.3	30.4	-12.3	-9.5	2.6	0.9	3.1	20.4	11.3	13.4	9.1
29.00	15.6	31.7	-10.6	-7.4	3.2	0.9	3.8	19.4	10.7	12.8	9.8
29.50	14.2	33.1	-9.4	-7.9	4.3	0.9	4.7	18.9	9.8	12.1	10.5
30.00	13.2	33.6	-9.2	-12.1	5.7	1.1	7.8	21.0	9.3	11.8	11.2

*Typical Performance Data*

**NOTE: Use PDF Bookmarks to view DATA at required conditions**

**Definitions:**

Input Return Loss = -S11 (dB)

Gain(Power Gain) = S21 (dB)

Reverse Isolation = -S12 (dB)

Output Return Loss = -S22 (dB)

TEST CONDITIONS: V<sub>CC</sub> = +5V, V<sub>B</sub> = +5.8V, V<sub>C</sub> = +5V, I<sub>CC</sub> = 105mA, I<sub>B</sub> = 5.6mA, I<sub>C</sub> = 1.3mA @ Temperature = -45°C

FREQ	Gain	Isolation	Input Return Loss	Output Return Loss	Stability		IP-3 Input	IP-3 Output	1dB Comp. Output	3dB Comp. Output	Noise Figure
					K	Measure					
(GHz)	(dB)	(dB)	(dB)	(dB)	K	Measure	(dBm)	(dBm)	(dBm)	(dBm)	(dB)
0.01	21.4	53.0	-16.8	-17.7	18.8	1.0	-	-	21.2	22.3	22.0
0.02	21.2	56.4	-16.6	-18.8	28.0	1.0	10.0	31.2	21.3	22.5	20.8
0.03	21.1	58.5	-16.4	-18.9	36.1	1.0	9.5	30.7	21.5	22.6	21.1
0.04	21.1	65.8	-16.4	-18.9	84.2	1.0	4.8	25.9	21.6	23.0	21.1
0.05	21.0	68.1	-16.4	-18.7	109.5	1.0	8.6	29.7	21.7	23.1	21.0
0.06	21.0	62.5	-16.3	-18.6	58.0	1.0	9.0	30.0	21.5	22.9	20.9
0.07	21.0	62.9	-16.3	-18.6	60.5	1.0	9.8	30.8	21.3	22.8	21.0
0.08	21.0	61.5	-16.3	-18.6	51.7	1.0	8.6	29.5	21.3	22.9	20.7
0.09	20.9	64.1	-16.4	-18.7	70.2	1.0	9.9	30.9	21.3	22.8	20.6
0.10	20.9	74.8	-16.4	-18.8	240.2	1.0	9.1	30.0	21.2	22.8	20.7
0.20	20.7	63.8	-16.7	-20.0	69.4	1.0	8.8	29.6	20.4	22.5	19.4
0.25	20.6	62.3	-17.0	-21.6	59.7	1.0	7.8	28.4	19.8	22.1	18.0
0.50	20.4	60.8	-16.2	-23.0	52.0	1.0	6.0	26.4	19.1	21.7	15.5
1.00	19.5	61.8	-14.4	-26.8	64.1	1.0	8.3	27.9	18.4	21.3	11.5
1.50	19.5	56.6	-14.9	-18.9	35.5	1.0	8.0	27.5	18.2	21.5	9.0
2.00	19.7	54.1	-15.1	-15.7	26.0	1.0	7.9	27.5	18.3	21.6	7.3
2.50	19.7	51.7	-14.9	-14.2	19.3	1.0	7.8	27.5	18.5	21.8	6.3
3.00	19.6	51.8	-13.8	-14.1	19.8	1.0	7.8	27.4	18.6	21.9	5.7
3.50	19.5	53.6	-12.7	-13.9	24.5	1.0	8.7	28.2	18.8	22.0	5.1
4.00	19.6	53.8	-12.7	-13.9	24.9	1.0	8.6	28.2	19.0	21.9	4.6
4.50	19.8	50.7	-13.2	-14.8	17.5	1.0	8.9	28.7	19.1	22.0	4.2
5.00	19.8	48.8	-13.5	-15.6	14.2	1.0	8.5	28.3	19.1	22.0	3.8
5.50	19.8	47.6	-13.8	-16.2	12.5	1.0	8.1	28.0	19.0	21.9	3.6
6.00	19.8	46.2	-14.4	-17.7	10.8	1.0	8.2	28.0	19.2	22.1	3.3
6.50	19.8	44.6	-14.8	-21.1	9.2	1.0	8.0	27.8	19.1	22.0	3.1
7.00	19.8	43.7	-14.9	-27.3	8.5	1.0	7.7	27.5	19.2	21.9	2.9
7.50	19.7	43.6	-14.8	-35.2	8.4	1.0	7.9	27.6	19.1	21.8	2.8
8.00	19.7	42.7	-15.3	-30.0	7.7	1.0	9.1	28.8	19.2	21.7	2.8
8.50	19.7	41.9	-16.7	-23.6	7.1	1.0	8.5	28.2	19.2	21.7	2.7
9.00	19.8	40.9	-19.9	-21.5	6.3	1.0	9.0	28.8	19.6	21.9	2.8
9.50	19.9	40.6	-27.2	-22.8	6.1	1.0	8.1	28.1	19.7	22.0	2.9
10.00	20.0	39.8	-24.5	-22.5	5.6	1.0	7.5	27.5	19.8	22.0	3.0
10.50	20.0	39.4	-19.0	-19.8	5.2	1.0	8.3	28.3	19.8	21.9	2.9
11.00	20.1	39.2	-17.2	-18.8	5.1	1.0	8.3	28.4	19.7	21.7	2.9
11.50	20.0	38.3	-16.2	-17.9	4.6	1.0	8.8	28.8	19.2	21.3	2.9
12.00	19.9	37.9	-15.0	-16.1	4.4	1.0	8.7	28.5	19.2	21.3	3.0
12.50	19.7	37.5	-13.8	-16.0	4.3	1.0	8.6	28.3	18.8	20.7	3.0
13.00	19.5	37.1	-13.5	-15.6	4.2	1.0	8.4	27.9	18.6	20.4	3.1
13.50	19.2	36.7	-13.3	-12.9	4.1	1.0	9.4	28.6	18.5	20.4	3.1
14.00	18.9	36.8	-13.1	-11.3	4.2	0.9	8.9	27.7	18.3	20.2	3.3
14.50	18.7	36.9	-13.4	-11.3	4.4	1.0	9.3	28.0	18.6	20.2	3.5
15.00	18.5	37.4	-14.9	-11.3	4.7	0.9	10.1	28.6	18.7	20.4	3.7
15.50	18.3	38.9	-16.2	-9.6	5.6	0.9	10.5	28.8	19.0	20.6	4.0
16.00	18.6	37.4	-18.2	-9.5	4.6	0.9	9.1	27.8	19.2	20.8	4.1
16.50	19.2	35.7	-20.3	-11.5	3.7	0.9	7.6	26.8	19.3	20.7	4.0
17.00	19.6	34.7	-18.5	-13.0	3.2	0.9	7.0	26.6	18.9	20.3	4.0
17.50	19.8	34.0	-15.8	-13.6	2.9	1.0	6.6	26.4	18.8	20.2	4.0
18.00	20.0	33.4	-14.9	-14.9	2.7	1.0	6.0	26.0	18.7	20.1	3.9
18.50	20.1	32.6	-15.6	-13.5	2.5	1.0	6.5	26.5	18.3	19.8	4.0
19.00	20.0	32.1	-16.4	-13.0	2.4	0.9	5.8	25.9	18.3	19.9	4.0
19.50	19.9	31.8	-13.5	-18.1	2.4	1.0	5.3	25.2	17.5	19.3	4.2
20.00	19.4	31.7	-11.2	-15.0	2.4	1.0	6.9	26.3	16.9	18.8	4.3
20.50	18.9	32.2	-11.6	-10.2	2.5	0.9	7.3	26.2	17.0	18.8	4.5
21.00	18.8	32.2	-15.0	-10.2	2.6	0.9	8.4	27.2	16.8	18.6	4.5
21.50	19.1	31.5	-19.1	-13.1	2.5	0.9	7.1	26.2	16.8	18.5	4.6
22.00	19.3	31.2	-19.6	-15.3	2.4	0.9	6.7	26.0	17.0	18.6	4.6
22.50	19.3	30.7	-16.3	-14.0	2.3	0.9	5.4	24.8	17.2	18.8	4.7
23.00	19.3	30.6	-12.5	-11.6	2.2	0.9	6.1	25.3	17.1	18.7	4.8
23.50	19.3	30.4	-12.2	-11.3	2.2	0.9	5.6	24.9	17.2	19.0	4.9
24.00	19.4	30.0	-15.0	-12.7	2.1	0.9	5.1	24.5	16.6	18.5	5.1
24.50	19.4	30.0	-19.0	-11.1	2.1	0.9	4.7	24.1	16.6	18.4	5.2
25.00	19.2	30.0	-19.7	-10.0	2.1	0.8	4.1	23.3	16.5	17.9	5.6
25.50	19.2	29.8	-18.5	-11.6	2.1	0.9	6.5	25.7	15.5	17.4	5.8
26.00	19.2	29.7	-19.4	-12.1	2.1	0.9	3.0	22.2	15.5	17.1	6.0
26.50	19.3	29.4	-26.5	-12.4	2.1	0.9	1.2	20.4	14.8	16.7	6.3
27.00	19.7	29.0	-20.9	-24.7	2.0	0.9	0.5	20.2	13.4	15.8	6.8
27.50	19.7	28.8	-14.8	-14.2	1.8	0.9	0.5	20.2	12.5	15.3	7.5
28.00	19.1	29.4	-13.7	-10.7	2.0	0.9	0.0	19.0	12.1	14.8	8.2
28.50	18.0	30.4	-12.2	-9.9	2.4	0.9	2.1	20.1	11.4	13.6	8.9
29.00	16.3	31.9	-10.4	-7.4	3.0	0.9	2.9	19.3	10.7	13.0	9.5
29.50	15.0	32.9	-9.1	-7.5	3.8	0.9	4.0	19.0	10.0	12.4	10.2
30.00	13.9	33.7	-9.0	-11.1	5.1	1.0	6.9	20.8	9.4	12.1	11.0

*Typical Performance Data*

**NOTE: Use PDF Bookmarks to view DATA at required conditions**

**Definitions:**

Input Return Loss = -S11 (dB)

Gain(Power Gain) = S21 (dB)

Reverse Isolation = -S12 (dB)

Output Return Loss = -S22 (dB)

TEST CONDITIONS:  $V_{CC} = +5V$ ,  $V_B = +5V$ ,  $V_C = +5V$ ,  $I_{CC} = 85mA$ ,  $I_B = 4.6mA$ ,  $I_C = 1.3mA$  @ Temperature = +85°C

FREQ	Gain	Isolation	Input Return Loss	Output Return Loss	Stability		IP-3 Input	IP-3 Output	1dB Comp. Output	3dB Comp. Output	Noise Figure
					K	Measure					
(GHz)	(dB)	(dB)	(dB)	(dB)	K	Measure	(dBm)	(dBm)	(dBm)	(dBm)	(dB)
0.01	19.0	52.2	-16.7	-17.8	22.4	1.0	-	-	20.1	21.6	22.0
0.02	18.8	58.5	-16.8	-18.3	46.8	1.0	12.5	31.3	20.0	21.6	21.5
0.03	18.7	61.7	-16.7	-18.4	69.0	1.0	8.3	27.1	20.0	21.6	21.6
0.04	18.7	59.5	-16.6	-18.4	53.8	1.0	13.4	32.1	20.0	21.9	21.5
0.05	18.6	65.1	-16.5	-18.3	102.3	1.0	11.2	29.8	20.0	21.9	21.5
0.06	18.6	56.8	-16.5	-18.3	39.6	1.0	9.8	28.4	20.0	21.8	21.5
0.07	18.6	66.8	-16.4	-18.3	126.0	1.0	9.8	28.4	19.9	21.8	21.4
0.08	18.6	65.8	-16.4	-18.4	112.5	1.0	11.5	30.1	20.0	21.9	21.2
0.09	18.5	62.0	-16.4	-18.4	73.1	1.0	12.0	30.5	19.9	21.8	21.2
0.10	18.5	68.8	-16.4	-18.6	159.8	1.0	12.2	30.7	19.8	21.8	21.1
0.20	18.2	67.5	-16.7	-19.5	143.1	1.0	10.2	28.4	19.1	21.5	19.9
0.25	18.1	66.2	-17.1	-20.4	126.1	1.0	10.5	28.6	18.6	21.1	18.5
0.50	17.8	59.2	-16.3	-20.8	58.0	1.0	8.3	26.0	17.9	20.9	16.1
1.00	16.9	58.4	-14.6	-24.0	59.1	1.0	9.7	26.6	17.1	20.5	12.2
1.50	16.8	55.9	-14.9	-18.3	44.3	1.0	9.3	26.2	16.8	20.7	9.7
2.00	16.9	54.0	-15.0	-15.5	35.2	1.0	9.5	26.4	16.9	20.8	8.3
2.50	17.0	51.6	-14.7	-14.1	26.4	1.0	8.5	25.5	17.1	20.8	7.3
3.00	16.9	52.3	-13.9	-13.8	28.6	1.0	10.0	26.9	17.2	20.9	6.7
3.50	16.8	54.1	-13.0	-13.8	35.4	1.0	9.8	26.6	17.5	21.1	6.1
4.00	16.9	53.3	-13.0	-14.2	32.6	1.0	10.3	27.2	17.6	21.2	5.7
4.50	17.0	50.7	-13.5	-15.3	24.2	1.0	9.4	26.4	17.6	21.1	5.1
5.00	17.1	49.2	-13.9	-15.8	20.8	1.0	10.3	27.3	17.6	20.8	4.6
5.50	17.0	47.2	-14.3	-16.7	16.9	1.0	9.8	26.8	17.6	21.0	4.4
6.00	17.0	45.6	-14.7	-19.4	14.4	1.0	10.2	27.2	17.7	21.3	4.3
6.50	16.9	44.8	-15.2	-24.7	13.4	1.0	10.1	27.0	17.6	20.8	4.1
7.00	16.9	44.0	-15.6	-33.4	12.5	1.0	10.2	27.0	17.6	20.6	4.1
7.50	16.8	43.1	-15.8	-39.5	11.5	1.0	10.5	27.3	17.6	20.6	4.1
8.00	16.8	42.0	-16.4	-27.3	10.1	1.0	10.7	27.5	17.7	20.6	4.1
8.50	16.8	41.5	-18.3	-23.1	9.7	1.0	10.3	27.1	17.8	20.7	4.2
9.00	16.9	40.9	-22.9	-22.3	9.0	1.0	9.8	26.7	18.0	20.5	4.3
9.50	17.0	40.4	-28.5	-21.6	8.6	1.0	10.2	27.2	18.1	20.6	4.4
10.00	17.0	39.6	-22.3	-19.5	7.7	1.0	10.1	27.1	18.2	20.6	4.4
10.50	17.0	39.4	-19.3	-18.3	7.5	1.0	9.7	26.7	18.0	20.2	4.5
11.00	17.0	38.9	-17.7	-17.6	7.1	1.0	10.0	27.0	18.1	20.3	4.4
11.50	16.9	38.6	-16.4	-16.4	6.9	1.0	11.1	27.9	17.9	20.0	4.5
12.00	16.7	38.1	-15.1	-15.6	6.6	1.0	9.9	26.6	17.6	19.7	4.6
12.50	16.4	37.5	-14.2	-15.1	6.4	1.0	11.1	27.5	17.7	19.5	4.7
13.00	16.1	37.1	-13.9	-13.3	6.2	1.0	11.4	27.5	16.9	18.7	4.7
13.50	15.8	36.9	-14.2	-11.6	6.2	1.0	10.6	26.4	17.0	18.8	4.9
14.00	15.6	37.0	-14.8	-11.1	6.4	0.9	11.6	27.1	16.9	18.8	5.1
14.50	15.4	36.9	-15.7	-11.1	6.6	0.9	11.8	27.2	17.1	18.8	5.3
15.00	15.2	37.6	-16.6	-10.9	7.2	0.9	12.5	27.7	17.3	19.0	5.7
15.50	15.3	38.0	-17.5	-10.7	7.5	0.9	11.0	26.3	17.4	19.1	5.9
16.00	15.8	36.3	-18.9	-11.9	6.1	0.9	11.5	27.3	17.4	18.9	5.9
16.50	16.1	35.2	-18.9	-13.4	5.3	1.0	9.9	26.0	17.3	19.0	5.9
17.00	16.3	34.4	-17.4	-14.8	4.7	1.0	9.8	26.1	17.4	19.0	5.9
17.50	16.5	33.7	-15.8	-17.0	4.4	1.0	9.0	25.4	16.7	18.3	6.0
18.00	16.5	33.0	-15.9	-16.0	4.0	1.0	9.1	25.6	16.3	18.1	6.0
18.50	16.4	32.7	-16.8	-14.6	3.9	1.0	10.9	27.3	16.5	18.4	6.1
19.00	16.3	32.2	-16.1	-17.1	3.9	1.0	9.1	25.4	16.5	18.4	6.1
19.50	16.0	32.1	-14.1	-17.2	3.9	1.0	8.5	24.5	15.4	17.3	6.4
20.00	15.5	32.2	-13.9	-12.9	4.0	1.0	8.6	24.1	15.0	16.7	6.5
20.50	15.3	32.3	-15.9	-11.7	4.2	0.9	9.5	24.8	14.9	16.6	6.7
21.00	15.4	31.9	-18.9	-12.8	4.1	1.0	9.4	24.8	14.9	16.7	6.9
21.50	15.5	31.4	-20.1	-14.5	3.9	1.0	10.3	25.8	14.9	16.8	7.0
22.00	15.5	31.2	-17.8	-14.4	3.8	1.0	8.7	24.2	14.5	16.4	7.1
22.50	15.4	31.0	-14.9	-12.7	3.7	1.0	7.7	23.2	14.3	16.4	7.2
23.00	15.3	30.9	-13.8	-11.8	3.6	0.9	7.4	22.7	14.4	16.8	7.4
23.50	15.3	30.5	-14.7	-11.7	3.5	0.9	7.4	22.7	13.9	16.3	7.6
24.00	15.1	30.5	-17.6	-11.3	3.6	0.9	7.2	22.3	13.5	15.7	7.8
24.50	15.0	30.4	-22.5	-11.6	3.7	0.9	6.1	21.1	13.3	15.8	8.1
25.00	15.0	30.2	-23.2	-13.2	3.7	0.9	6.7	21.8	12.9	15.2	8.4
25.50	15.0	30.1	-22.6	-15.1	3.7	1.0	4.6	19.7	12.3	14.7	8.7
26.00	15.0	29.9	-23.2	-18.6	3.7	1.0	3.2	18.2	11.5	14.0	9.0
26.50	14.9	29.9	-17.2	-28.6	3.8	1.0	3.5	18.3	10.0	12.8	9.4
27.00	14.1	30.3	-13.9	-15.4	4.1	1.0	3.2	17.3	9.9	12.7	10.2
27.50	13.0	31.5	-13.8	-13.0	5.2	1.0	4.8	17.8	10.3	12.8	11.0
28.00	11.7	32.7	-14.0	-11.9	7.0	1.0	7.0	18.7	9.5	11.8	11.8
28.50	10.2	33.4	-12.6	-10.5	8.6	1.0	7.1	17.3	9.0	11.2	12.8
29.00	8.8	35.4	-11.4	-10.8	12.5	1.0	8.3	17.1	8.5	10.7	13.7
29.50	7.6	35.8	-11.0	-13.7	15.9	1.0	8.0	15.6	7.4	9.9	14.4
30.00	6.2	37.2	-11.6	-19.0	22.8	1.1	7.2	13.4	6.2	9.1	15.3

*Typical Performance Data*

**NOTE: Use PDF Bookmarks to view DATA at required conditions**

**Definitions:**

Input Return Loss = -S11 (dB)

Gain(Power Gain) = S21 (dB)

Reverse Isolation = -S12 (dB)

Output Return Loss = -S22 (dB)

TEST CONDITIONS: V<sub>CC</sub> = +5V, V<sub>B</sub> = +5.4V, V<sub>C</sub> = +5V, I<sub>CC</sub> = 94mA, I<sub>B</sub> = 5.2mA, I<sub>C</sub> = 1.4mA @ Temperature = +85°C

FREQ	Gain	Isolation	Input Return Loss	Output Return Loss	Stability		IP-3 Input	IP-3 Output	1dB Comp. Output	3dB Comp. Output	Noise Figure
					K	Measure					
(GHz)	(dB)	(dB)	(dB)	(dB)	K	Measure	(dBm)	(dBm)	(dBm)	(dBm)	(dB)
0.01	19.1	59.4	-16.8	-17.6	50.4	1.0	-	-	20.6	21.9	22.3
0.02	19.0	73.9	-16.9	-18.4	271.3	1.0	9.6	28.5	20.6	21.8	21.8
0.03	18.9	62.8	-16.6	-18.4	76.3	1.0	9.5	28.4	20.6	21.9	21.9
0.04	18.8	58.6	-16.4	-18.5	47.3	1.0	8.9	27.7	20.7	22.2	21.8
0.05	18.8	63.6	-16.4	-18.4	84.7	1.0	9.5	28.3	20.7	22.2	21.8
0.06	18.7	58.0	-16.5	-18.4	44.6	1.0	13.2	32.0	20.6	22.1	21.9
0.07	18.7	61.7	-16.4	-18.3	68.3	1.0	9.8	28.5	20.6	22.1	21.8
0.08	18.7	66.5	-16.4	-18.4	119.5	1.0	10.2	28.9	20.6	22.2	21.6
0.09	18.7	64.8	-16.4	-18.4	98.1	1.0	9.6	28.3	20.5	22.1	21.5
0.10	18.7	69.2	-16.4	-18.5	162.7	1.0	11.3	30.0	20.5	22.0	21.5
0.20	18.5	68.5	-16.7	-19.5	154.8	1.0	9.8	28.2	19.7	21.8	20.2
0.25	18.3	69.1	-17.1	-20.6	170.4	1.0	8.8	27.2	19.1	21.5	18.8
0.50	18.1	64.3	-16.2	-20.9	100.4	1.0	8.9	27.0	18.4	21.3	16.4
1.00	17.3	59.4	-14.6	-24.2	63.1	1.0	9.0	26.3	17.5	20.9	12.5
1.50	17.2	55.1	-14.8	-18.4	38.6	1.0	8.9	26.1	17.3	21.1	9.9
2.00	17.3	54.5	-14.9	-15.5	35.4	1.0	9.4	26.8	17.4	21.2	8.4
2.50	17.4	52.1	-14.7	-14.1	26.5	1.0	9.2	26.6	17.5	21.2	7.5
3.00	17.3	51.5	-13.8	-13.8	24.8	1.0	9.2	26.6	17.7	21.3	6.8
3.50	17.2	54.2	-13.0	-13.8	34.3	1.0	9.3	26.6	17.9	21.5	6.3
4.00	17.3	52.8	-13.0	-14.2	29.1	1.0	9.4	26.7	18.0	21.6	5.7
4.50	17.4	51.0	-13.5	-15.2	23.9	1.0	10.7	28.1	18.1	21.5	5.2
5.00	17.4	48.7	-13.9	-15.7	18.6	1.0	9.6	27.1	18.0	21.1	4.7
5.50	17.4	47.2	-14.2	-16.6	15.9	1.0	8.8	26.2	18.1	21.4	4.5
6.00	17.4	45.5	-14.7	-19.2	13.5	1.0	9.1	26.4	18.1	21.7	4.4
6.50	17.3	45.1	-15.3	-24.3	13.2	1.0	10.2	27.6	18.0	21.1	4.3
7.00	17.2	43.8	-15.6	-32.7	11.6	1.0	9.3	26.5	18.0	21.0	4.1
7.50	17.2	43.1	-15.8	-40.4	10.9	1.0	9.5	26.7	18.1	21.0	4.1
8.00	17.2	42.1	-16.4	-27.7	9.8	1.0	9.6	26.8	18.2	21.0	4.2
8.50	17.2	41.8	-18.4	-23.2	9.5	1.0	9.4	26.6	18.3	21.2	4.2
9.00	17.3	41.1	-22.8	-22.4	8.9	1.0	9.2	26.5	18.4	20.9	4.3
9.50	17.3	40.6	-28.3	-21.8	8.3	1.0	10.0	27.4	18.6	21.1	4.4
10.00	17.4	39.7	-22.4	-19.6	7.5	1.0	9.6	27.0	18.7	21.1	4.5
10.50	17.4	39.5	-19.3	-18.4	7.3	1.0	9.0	26.5	18.4	20.6	4.5
11.00	17.4	38.8	-17.7	-17.7	6.7	1.0	9.9	27.3	18.5	20.8	4.5
11.50	17.3	38.2	-16.5	-16.5	6.3	1.0	9.9	27.2	18.3	20.4	4.5
12.00	17.1	37.8	-15.2	-15.8	6.2	1.0	9.2	26.2	18.0	20.2	4.6
12.50	16.8	37.4	-14.2	-15.3	6.0	1.0	9.7	26.6	18.0	20.0	4.7
13.00	16.6	37.2	-13.9	-13.4	6.0	1.0	10.3	26.8	17.2	19.2	4.8
13.50	16.2	36.8	-14.2	-11.7	5.8	1.0	11.3	27.5	17.4	19.3	4.9
14.00	16.0	36.8	-14.7	-11.1	6.0	0.9	10.5	26.5	17.4	19.3	5.1
14.50	15.8	37.0	-15.6	-11.2	6.3	0.9	11.5	27.3	17.5	19.3	5.3
15.00	15.6	37.8	-16.6	-10.8	7.1	0.9	11.1	26.7	17.7	19.5	5.7
15.50	15.7	37.9	-17.5	-10.6	7.2	0.9	10.4	26.1	17.9	19.6	5.8
16.00	16.1	36.5	-19.0	-11.7	6.0	0.9	10.6	26.7	17.9	19.4	5.8
16.50	16.5	35.2	-19.0	-13.1	5.0	1.0	9.6	26.1	17.8	19.5	5.9
17.00	16.7	34.4	-17.6	-14.5	4.5	1.0	9.1	25.8	17.9	19.6	5.9
17.50	16.9	33.6	-15.9	-16.7	4.1	1.0	9.2	26.0	17.1	18.9	6.0
18.00	16.9	33.2	-15.9	-15.8	3.9	1.0	8.3	25.2	16.7	18.6	6.0
18.50	16.8	32.6	-16.8	-14.4	3.7	1.0	9.1	25.9	16.9	18.9	6.1
19.00	16.7	32.3	-16.0	-16.9	3.7	1.0	8.3	25.0	17.0	19.0	6.2
19.50	16.4	32.3	-14.0	-17.4	3.8	1.0	7.8	24.2	15.8	17.9	6.4
20.00	16.0	32.2	-13.7	-12.9	3.8	1.0	8.1	24.1	15.3	17.1	6.6
20.50	15.7	32.3	-15.8	-11.6	4.0	0.9	8.8	24.5	15.3	17.1	6.7
21.00	15.8	31.8	-18.9	-12.7	3.9	0.9	8.5	24.2	15.3	17.2	6.8
21.50	15.9	31.6	-20.3	-14.4	3.8	1.0	8.6	24.5	15.3	17.3	6.9
22.00	15.9	31.1	-18.1	-14.6	3.6	1.0	8.4	24.4	14.9	16.9	7.1
22.50	15.9	30.9	-15.0	-13.0	3.5	1.0	6.9	22.7	14.7	16.8	7.2
23.00	15.8	30.8	-13.8	-12.0	3.4	0.9	7.4	23.2	14.9	17.4	7.4
23.50	15.7	30.6	-14.7	-11.8	3.4	0.9	7.5	23.2	14.4	16.8	7.7
24.00	15.6	30.6	-17.5	-11.4	3.5	0.9	6.4	22.1	13.9	16.1	7.9
24.50	15.5	30.4	-22.1	-11.5	3.5	0.9	5.7	21.2	13.9	16.3	8.1
25.00	15.5	30.3	-22.7	-13.0	3.6	0.9	6.3	21.8	13.3	15.7	8.3
25.50	15.5	30.1	-22.1	-14.5	3.5	0.9	4.2	19.7	12.7	15.2	8.5
26.00	15.5	29.9	-23.6	-17.4	3.5	1.0	2.9	18.4	12.0	14.5	8.9
26.50	15.4	29.8	-17.8	-32.8	3.5	1.0	2.8	18.2	10.2	13.2	9.4
27.00	14.8	30.4	-14.0	-16.3	3.9	1.0	2.6	17.4	9.9	13.0	10.1
27.50	13.8	31.3	-13.6	-13.4	4.8	1.0	4.8	18.6	10.3	13.1	10.8
28.00	12.5	32.3	-13.7	-12.1	6.1	1.0	5.6	18.1	9.7	12.2	11.7
28.50	11.0	33.8	-12.4	-10.4	8.2	1.0	6.1	17.1	9.0	11.5	12.6
29.00	9.6	34.8	-11.2	-10.5	10.6	1.0	7.3	16.9	8.6	11.2	13.4
29.50	8.4	35.6	-10.9	-13.0	14.0	1.0	7.5	15.9	7.8	10.3	14.2
30.00	7.0	36.8	-11.4	-17.6	19.5	1.1	6.9	14.0	6.6	9.5	15.2

*Typical Performance Data*

**NOTE: Use PDF Bookmarks to view DATA at required conditions**

**Definitions:**

Input Return Loss = -S11 (dB)

Gain(Power Gain) = S21 (dB)

Reverse Isolation = -S12 (dB)

Output Return Loss = -S22 (dB)

TEST CONDITIONS:  $V_{CC} = +5V$ ,  $V_B = +5.8V$ ,  $V_C = +5V$ ,  $I_{CC} = 104mA$ ,  $I_B = 5.7mA$ ,  $I_C = 1.4mA$  @ Temperature = +85°C

FREQ	Gain	Isolation	Input Return Loss	Output Return Loss	Stability		IP-3 Input	IP-3 Output	1dB Comp. Output	3dB Comp. Output	Noise Figure
					K	Measure					
(GHz)	(dB)	(dB)	(dB)	(dB)	K	Measure	(dBm)	(dBm)	(dBm)	(dBm)	(dB)
0.01	19.2	66.5	-16.7	-17.6	112.2	1.0	-	-	21.1	22.1	22.6
0.02	19.1	51.6	-16.5	-18.4	20.5	1.0	14.6	33.7	21.0	22.0	22.1
0.03	19.0	66.5	-16.6	-18.4	115.2	1.0	8.7	27.7	21.0	22.1	22.2
0.04	19.0	69.8	-16.4	-18.5	169.3	1.0	9.7	28.7	21.2	22.4	22.1
0.05	18.9	65.7	-16.4	-18.4	106.2	1.0	9.3	28.2	21.2	22.4	22.1
0.06	18.9	67.2	-16.4	-18.5	126.4	1.0	12.1	31.0	21.1	22.3	22.1
0.07	18.9	58.8	-16.4	-18.4	48.2	1.0	11.8	30.7	21.1	22.3	22.1
0.08	18.8	69.6	-16.4	-18.4	167.9	1.0	10.6	29.5	21.1	22.4	21.9
0.09	18.8	70.2	-16.4	-18.4	181.0	1.0	13.1	32.0	21.0	22.3	21.8
0.10	18.8	66.4	-16.4	-18.5	116.1	1.0	10.2	29.0	20.9	22.3	21.8
0.20	18.7	78.3	-16.7	-19.5	469.3	1.0	9.1	27.7	20.2	22.1	20.4
0.25	18.6	64.2	-17.1	-20.6	94.6	1.0	8.0	26.6	19.5	21.8	19.0
0.50	18.4	62.7	-16.2	-21.1	80.9	1.0	9.6	28.0	18.8	21.6	16.6
1.00	17.5	61.6	-14.6	-24.5	79.2	1.0	9.0	26.5	17.9	21.2	12.7
1.50	17.5	55.1	-14.8	-18.4	37.3	1.0	8.9	26.4	17.6	21.4	10.2
2.00	17.6	53.5	-14.9	-15.5	30.5	1.0	8.8	26.5	17.8	21.5	8.6
2.50	17.7	51.3	-14.6	-14.2	23.4	1.0	8.5	26.2	17.9	21.5	7.6
3.00	17.6	51.5	-13.8	-13.8	24.2	1.0	8.7	26.3	18.0	21.6	6.9
3.50	17.5	54.3	-12.9	-13.8	33.5	1.0	9.5	27.0	18.2	21.8	6.4
4.00	17.6	53.9	-12.9	-14.1	32.0	1.0	9.8	27.4	18.3	21.9	5.8
4.50	17.7	50.4	-13.4	-15.1	21.6	1.0	9.3	27.0	18.4	21.8	5.3
5.00	17.7	48.5	-13.9	-15.6	17.7	1.0	9.5	27.2	18.4	21.4	4.7
5.50	17.7	47.2	-14.2	-16.5	15.5	1.0	9.1	26.8	18.4	21.7	4.6
6.00	17.7	45.6	-14.7	-19.0	13.2	1.0	9.2	26.8	18.4	22.1	4.4
6.50	17.6	44.5	-15.3	-24.0	11.9	1.0	8.9	26.5	18.3	21.5	4.4
7.00	17.5	43.5	-15.6	-31.9	10.9	1.0	9.2	26.8	18.3	21.4	4.2
7.50	17.5	42.7	-15.9	-41.4	10.1	1.0	9.5	27.0	18.4	21.4	4.2
8.00	17.5	42.1	-16.5	-27.9	9.5	1.0	8.5	26.0	18.5	21.4	4.1
8.50	17.5	41.8	-18.4	-23.3	9.2	1.0	10.4	27.9	18.7	21.6	4.2
9.00	17.6	40.9	-22.9	-22.5	8.4	1.0	9.6	27.2	18.8	21.3	4.3
9.50	17.6	40.3	-28.2	-21.8	7.9	1.0	9.6	27.2	18.9	21.5	4.4
10.00	17.7	39.8	-22.3	-19.8	7.3	1.0	9.9	27.5	19.0	21.5	4.5
10.50	17.7	39.2	-19.3	-18.5	6.8	1.0	8.5	26.2	18.8	21.0	4.6
11.00	17.7	38.8	-17.8	-17.9	6.5	1.0	8.9	26.5	18.7	21.1	4.5
11.50	17.5	38.4	-16.5	-16.7	6.3	1.0	9.3	26.8	18.6	20.8	4.5
12.00	17.3	37.9	-15.2	-15.9	6.0	1.0	8.5	25.9	18.3	20.6	4.6
12.50	17.1	37.6	-14.2	-15.5	5.9	1.0	10.0	27.1	18.3	20.4	4.7
13.00	16.8	37.1	-13.9	-13.6	5.7	1.0	9.4	26.2	17.5	19.6	4.7
13.50	16.5	37.1	-14.1	-11.8	5.8	1.0	10.0	26.5	17.6	19.7	4.9
14.00	16.3	36.9	-14.7	-11.2	5.9	0.9	10.1	26.4	17.7	19.7	5.1
14.50	16.1	37.0	-15.6	-11.2	6.1	0.9	10.0	26.1	17.7	19.8	5.4
15.00	15.9	37.7	-16.6	-10.9	6.8	0.9	10.9	26.8	18.0	19.9	5.7
15.50	15.9	37.9	-17.5	-10.5	6.9	0.9	10.1	26.0	18.3	20.0	5.9
16.00	16.4	36.4	-19.0	-11.6	5.7	0.9	9.8	26.2	18.2	19.9	6.0
16.50	16.8	35.5	-19.1	-12.9	5.0	1.0	8.5	25.3	18.1	20.0	5.9
17.00	17.0	34.3	-17.6	-14.3	4.4	1.0	8.7	25.7	18.2	20.0	6.0
17.50	17.1	33.7	-15.9	-16.5	4.1	1.0	8.6	25.8	17.4	19.3	6.0
18.00	17.2	33.0	-15.9	-15.7	3.7	1.0	8.4	25.5	16.9	18.9	6.1
18.50	17.1	32.8	-16.8	-14.3	3.7	1.0	7.9	25.0	17.1	19.3	6.1
19.00	17.0	32.3	-16.0	-16.7	3.6	1.0	8.0	25.0	17.3	19.5	6.3
19.50	16.7	32.2	-14.0	-17.5	3.6	1.0	6.7	23.4	16.0	18.3	6.4
20.00	16.3	32.2	-13.7	-13.0	3.7	1.0	7.0	23.2	15.4	17.5	6.6
20.50	16.0	32.3	-15.7	-11.6	3.8	0.9	8.8	24.8	15.5	17.5	6.7
21.00	16.0	32.0	-18.8	-12.6	3.8	0.9	7.7	23.7	15.6	17.6	6.9
21.50	16.2	31.6	-20.4	-14.3	3.7	1.0	8.4	24.6	15.5	17.7	7.0
22.00	16.2	31.3	-18.2	-14.7	3.5	1.0	7.2	23.4	15.0	17.3	7.1
22.50	16.2	31.0	-15.1	-13.3	3.4	1.0	6.7	22.9	14.9	17.2	7.3
23.00	16.1	30.9	-13.8	-12.3	3.4	0.9	6.7	22.8	15.1	17.7	7.4
23.50	16.0	30.6	-14.7	-12.0	3.3	0.9	6.0	22.1	14.6	17.2	7.6
24.00	15.9	30.5	-17.4	-11.5	3.3	0.9	6.1	22.0	14.0	16.4	7.9
24.50	15.8	30.5	-21.9	-11.5	3.4	0.9	5.1	20.9	14.0	16.6	8.1
25.00	15.7	30.4	-22.5	-12.9	3.5	0.9	5.6	21.3	13.5	16.0	8.3
25.50	15.7	30.2	-21.8	-14.2	3.5	0.9	4.0	19.7	12.8	15.5	8.6
26.00	15.7	30.0	-23.6	-16.5	3.5	1.0	2.5	18.2	12.1	14.8	8.9
26.50	15.7	29.9	-18.3	-30.4	3.5	1.0	2.4	18.0	10.3	13.5	9.2
27.00	15.2	30.1	-14.2	-17.6	3.6	1.0	2.2	17.3	9.9	13.1	9.9
27.50	14.3	30.7	-13.6	-14.1	4.2	1.0	3.2	17.5	10.2	13.2	10.6
28.00	13.1	32.0	-13.6	-12.4	5.5	1.0	5.3	18.4	9.6	12.4	11.6
28.50	11.6	33.1	-12.3	-10.4	7.0	1.0	5.2	16.8	9.0	11.7	12.4
29.00	10.2	34.3	-11.1	-10.2	9.3	1.0	6.4	16.6	8.4	11.4	13.2
29.50	9.0	35.4	-10.7	-12.4	12.5	1.0	6.7	15.7	7.7	10.6	14.1
30.00	7.7	36.2	-11.2	-16.3	16.8	1.1	6.5	14.2	6.9	9.8	14.9

*Typical Performance Data*

**NOTE: Use PDF Bookmarks to view DATA at required conditions**

**Definitions:**

- Input Return Loss = -S11 (dB)
- Gain(Power Gain) = S21 (dB)
- Reverse Isolation = -S12 (dB)
- Output Return Loss = -S22 (dB)

TEST CONDITIONS:  $V_{CC} = +5V$ ,  $V_B = +5V$ ,  $V_C = +5V$ ,  $I_{CC} = 85mA$ ,  $I_B = 4.7mA$ ,  $I_C = 1.3mA$  @ Temperature = +105°C

FREQ	Gain	Isolation	Input Return Loss	Output Return Loss	Stability		IP-3 Input	IP-3 Output	1dB Comp. Output	3dB Comp. Output	Noise Figure
					K	Measure					
(GHz)	(dB)	(dB)	(dB)	(dB)	K	Measure	(dBm)	(dBm)	(dBm)	(dBm)	(dB)
0.01	18.6	63.5	-16.8	-17.5	85.5	1.0	-	-	19.7	21.2	22.3
0.02	18.5	64.0	-16.7	-18.2	91.6	1.0	10.0	28.4	19.8	21.4	21.4
0.03	18.4	66.1	-16.7	-18.3	118.8	1.0	10.3	28.7	19.9	21.5	21.8
0.04	18.3	61.0	-16.6	-18.3	66.4	1.0	12.8	31.1	20.0	21.8	21.8
0.05	18.3	65.4	-16.5	-18.4	111.2	1.0	10.2	28.5	20.1	21.9	21.9
0.06	18.2	66.4	-16.5	-18.3	125.6	1.0	7.6	25.7	19.9	21.7	21.7
0.07	18.2	70.6	-16.5	-18.3	204.1	1.0	9.1	27.3	19.9	21.6	21.8
0.08	18.2	68.9	-16.4	-18.3	168.1	1.0	11.7	29.9	19.8	21.7	21.6
0.09	18.1	75.5	-16.5	-18.4	358.1	1.0	11.0	29.1	19.8	21.6	21.5
0.10	18.1	67.3	-16.4	-18.5	140.5	1.0	13.3	31.4	19.8	21.6	21.5
0.20	17.8	73.4	-16.7	-19.5	293.0	1.0	9.7	27.5	19.1	21.4	20.2
0.25	17.6	75.9	-17.2	-20.4	401.7	1.0	10.3	27.9	18.5	21.0	18.8
0.50	17.3	67.8	-16.3	-20.5	165.4	1.0	10.2	27.6	17.8	20.7	16.4
1.00	16.4	60.3	-14.6	-23.7	77.5	1.0	10.6	27.0	17.1	20.4	12.5
1.50	16.4	56.3	-14.8	-18.2	48.8	1.0	9.3	25.7	16.8	20.6	10.1
2.00	16.5	55.1	-14.9	-15.4	41.9	1.0	9.5	26.0	16.9	20.6	8.6
2.50	16.6	53.3	-14.7	-14.1	33.6	1.0	10.2	26.7	17.1	20.8	7.6
3.00	16.5	52.2	-13.9	-13.8	29.7	1.0	9.8	26.3	17.2	21.0	7.0
3.50	16.4	53.9	-13.0	-13.8	36.7	1.0	10.3	26.8	17.4	21.1	6.6
4.00	16.5	53.5	-13.0	-14.3	35.0	1.0	10.5	27.1	17.6	20.9	6.1
4.50	16.6	51.7	-13.5	-15.3	28.6	1.0	10.2	26.8	17.7	21.0	5.7
5.00	16.6	48.9	-14.0	-15.9	21.1	1.0	10.2	26.8	17.6	21.1	5.3
5.50	16.6	47.1	-14.3	-16.9	17.6	1.0	10.2	26.7	17.7	20.9	5.0
6.00	16.5	45.7	-14.7	-19.7	15.4	1.0	10.8	27.3	17.6	20.9	4.8
6.50	16.4	44.4	-15.4	-25.3	13.6	1.0	10.3	26.7	17.7	20.8	4.6
7.00	16.4	43.7	-15.8	-35.1	12.8	1.0	10.4	26.8	17.6	20.6	4.6
7.50	16.3	43.0	-16.1	-39.4	11.9	1.0	10.0	26.3	17.7	20.5	4.5
8.00	16.3	42.1	-16.8	-27.3	10.9	1.0	10.1	26.4	17.7	20.4	4.5
8.50	16.4	41.8	-18.8	-23.1	10.6	1.0	9.8	26.1	17.7	20.4	4.6
9.00	16.4	40.7	-23.5	-22.1	9.4	1.0	10.5	26.9	18.1	20.6	4.7
9.50	16.4	40.1	-27.9	-21.2	8.8	1.0	10.9	27.4	18.1	20.6	4.8
10.00	16.5	39.7	-22.1	-19.4	8.4	1.0	10.6	27.1	18.1	20.5	4.9
10.50	16.5	39.3	-19.2	-18.2	7.9	1.0	10.6	27.2	18.1	20.4	5.0
11.00	16.5	38.9	-17.6	-17.4	7.6	1.0	10.7	27.2	18.0	20.2	5.0
11.50	16.3	38.4	-16.5	-16.2	7.3	1.0	11.2	27.5	17.6	19.7	5.0
12.00	16.1	37.8	-15.2	-15.5	6.9	1.0	10.2	26.3	17.6	19.7	5.1
12.50	15.8	37.5	-14.3	-14.8	6.8	1.0	10.8	26.6	17.2	19.2	5.1
13.00	15.6	37.2	-14.1	-13.0	6.7	1.0	10.7	26.3	17.1	18.9	5.3
13.50	15.2	36.8	-14.4	-11.5	6.5	1.0	11.4	26.7	16.9	18.8	5.4
14.00	15.0	36.9	-15.1	-11.1	6.9	0.9	11.1	26.1	16.9	18.7	5.7
14.50	14.8	37.1	-16.0	-11.2	7.2	0.9	12.1	26.9	16.9	18.7	5.9
15.00	14.7	37.7	-16.7	-11.0	7.9	0.9	12.6	27.3	17.1	18.9	6.3
15.50	14.8	37.6	-17.7	-11.0	7.8	0.9	11.6	26.4	17.2	19.0	6.5
16.00	15.2	36.3	-19.1	-12.3	6.6	0.9	10.9	26.1	17.3	19.0	6.5
16.50	15.5	35.2	-18.9	-13.7	5.7	1.0	9.9	25.4	17.2	18.8	6.6
17.00	15.7	34.3	-17.4	-15.4	5.1	1.0	11.1	26.8	16.8	18.4	6.6
17.50	15.8	33.8	-15.9	-17.6	4.8	1.0	10.2	26.1	16.6	18.4	6.7
18.00	15.8	33.2	-16.1	-16.3	4.5	1.0	9.1	24.9	16.4	18.3	6.7
18.50	15.7	32.7	-17.1	-15.0	4.3	1.0	9.5	25.2	16.1	17.9	6.7
19.00	15.6	32.2	-16.1	-17.7	4.2	1.0	9.3	24.9	15.9	17.8	6.9
19.50	15.2	32.3	-14.2	-16.8	4.4	1.0	9.5	24.7	15.4	17.3	7.1
20.00	14.8	32.3	-14.2	-12.9	4.5	1.0	9.5	24.3	15.0	16.8	7.3
20.50	14.6	32.3	-16.5	-11.9	4.6	0.9	10.2	24.8	14.9	16.7	7.4
21.00	14.6	31.9	-19.5	-13.1	4.5	1.0	9.0	23.6	14.7	16.5	7.5
21.50	14.7	31.5	-20.2	-14.7	4.3	1.0	9.0	23.7	14.3	16.2	7.7
22.00	14.7	31.2	-17.7	-14.4	4.2	1.0	8.4	23.1	14.3	16.3	7.8
22.50	14.6	31.1	-15.1	-12.8	4.1	1.0	8.2	22.7	14.2	16.4	8.0
23.00	14.5	30.9	-14.3	-11.9	4.0	0.9	8.1	22.6	13.9	16.1	8.2
23.50	14.4	30.7	-15.4	-11.8	4.1	0.9	7.5	21.9	13.5	15.9	8.3
24.00	14.2	30.7	-18.4	-11.6	4.1	0.9	7.4	21.6	13.1	15.6	8.6
24.50	14.1	30.5	-23.1	-12.0	4.2	0.9	6.6	20.7	12.7	15.2	8.9
25.00	14.1	30.4	-24.0	-14.0	4.3	0.9	5.9	19.9	12.2	14.6	9.2
25.50	14.0	30.3	-23.1	-16.6	4.3	1.0	5.5	19.5	11.8	14.3	9.5
26.00	13.9	30.2	-20.8	-21.9	4.4	1.0	4.3	18.1	10.8	13.4	9.9
26.50	13.5	30.5	-15.8	-23.1	4.7	1.0	4.8	18.3	10.1	12.9	10.5
27.00	12.6	31.3	-13.7	-15.1	5.5	1.0	4.7	17.3	9.7	12.4	11.1
27.50	11.5	32.0	-14.1	-13.6	6.8	1.0	6.2	17.7	9.6	12.0	12.0
28.00	10.2	32.9	-14.4	-12.8	8.7	1.0	7.2	17.3	9.0	11.4	12.9
28.50	8.7	34.2	-13.1	-11.3	11.6	1.0	8.3	17.0	8.2	10.6	13.8
29.00	7.3	35.0	-11.9	-11.6	14.8	1.0	8.3	15.6	7.6	9.9	14.6
29.50	6.0	36.7	-11.5	-14.2	21.5	1.0	7.9	13.9	6.6	9.2	15.5
30.00	4.7	37.0	-11.8	-19.5	26.9	1.1	7.7	12.4	5.5	8.3	16.4



*Typical Performance Data*

**NOTE: Use PDF Bookmarks to view DATA at required conditions**

**Definitions:**

Input Return Loss = -S11 (dB)

Gain(Power Gain) = S21 (dB)

Reverse Isolation = -S12 (dB)

Output Return Loss = -S22 (dB)

TEST CONDITIONS: V<sub>CC</sub> = +5V, V<sub>B</sub> = +5.4V, V<sub>C</sub> = +5V, I<sub>CC</sub> = 94mA, I<sub>B</sub> = 5.3mA, I<sub>C</sub> = 1.4mA @ Temperature = +105°C

FREQ	Gain	Isolation	Input Return Loss	Output Return Loss	Stability		IP-3 Input	IP-3 Output	1dB Comp. Output	3dB Comp. Output	Noise Figure
					K	Measure					
(GHz)	(dB)	(dB)	(dB)	(dB)	K	Measure	(dBm)	(dBm)	(dBm)	(dBm)	(dB)
0.01	18.8	66.7	-16.8	-17.5	122.5	1.0	-	-	20.3	21.5	22.6
0.02	18.6	53.4	-16.7	-18.2	26.8	1.0	9.1	27.7	20.4	21.6	21.8
0.03	18.5	66.1	-16.7	-18.3	117.3	1.0	11.1	29.7	20.5	21.7	22.1
0.04	18.5	62.0	-16.5	-18.3	73.1	1.0	10.9	29.4	20.6	22.1	22.1
0.05	18.4	61.4	-16.5	-18.3	68.6	1.0	13.6	32.1	20.7	22.1	22.1
0.06	18.4	59.7	-16.4	-18.3	56.7	1.0	9.7	28.0	20.5	22.0	22.1
0.07	18.4	65.3	-16.4	-18.2	108.4	1.0	9.9	28.2	20.5	21.8	22.1
0.08	18.3	62.6	-16.4	-18.3	79.8	1.0	11.1	29.5	20.4	21.9	21.9
0.09	18.3	65.6	-16.5	-18.4	112.5	1.0	13.4	31.7	20.5	21.9	21.9
0.10	18.3	62.7	-16.4	-18.4	80.8	1.0	10.7	29.0	20.4	21.8	21.8
0.20	18.1	84.6	-16.7	-19.5	1034.9	1.0	9.6	27.7	19.6	21.6	20.5
0.25	17.9	70.4	-17.1	-20.4	208.3	1.0	8.4	26.4	19.0	21.4	19.1
0.50	17.7	78.5	-16.3	-20.7	543.6	1.0	8.3	26.0	18.4	21.0	16.7
1.00	16.8	62.4	-14.6	-23.9	94.0	1.0	9.7	26.5	17.5	20.7	12.7
1.50	16.8	56.8	-14.8	-18.3	49.5	1.0	8.5	25.3	17.2	21.0	10.3
2.00	16.9	54.0	-14.9	-15.5	35.3	1.0	11.0	27.9	17.5	21.0	8.8
2.50	16.9	52.0	-14.6	-14.1	27.9	1.0	9.6	26.5	17.5	21.2	7.9
3.00	16.9	52.0	-13.8	-13.8	28.0	1.0	9.8	26.7	17.6	21.3	7.2
3.50	16.8	53.5	-13.0	-13.8	33.6	1.0	9.9	26.7	17.8	21.4	6.6
4.00	16.9	52.3	-13.0	-14.2	29.1	1.0	9.8	26.6	18.0	21.3	6.2
4.50	17.0	49.9	-13.5	-15.3	22.3	1.0	10.4	27.3	18.1	21.4	5.8
5.00	17.0	48.3	-13.9	-15.8	18.8	1.0	9.6	26.5	18.0	21.4	5.4
5.50	16.9	47.0	-14.3	-16.8	16.6	1.0	10.3	27.2	18.1	21.3	5.1
6.00	16.9	45.5	-14.7	-19.5	14.4	1.0	9.6	26.5	18.0	21.3	4.8
6.50	16.8	44.6	-15.4	-25.0	13.2	1.0	9.7	26.5	18.1	21.3	4.7
7.00	16.7	43.4	-15.8	-34.0	11.9	1.0	10.0	26.8	18.0	21.0	4.6
7.50	16.7	43.2	-16.1	-40.7	11.7	1.0	9.6	26.3	18.0	20.9	4.5
8.00	16.7	42.2	-16.8	-27.7	10.5	1.0	10.1	26.8	18.1	20.8	4.6
8.50	16.7	41.6	-18.9	-23.3	9.9	1.0	10.1	26.8	18.3	20.8	4.7
9.00	16.8	40.7	-23.5	-22.2	9.0	1.0	11.0	27.8	18.4	21.0	4.7
9.50	16.8	40.4	-27.8	-21.3	8.7	1.0	10.6	27.4	18.5	21.0	4.8
10.00	16.9	39.8	-22.1	-19.5	8.1	1.0	10.0	26.9	18.7	21.0	5.0
10.50	16.9	39.2	-19.2	-18.3	7.5	1.0	10.2	27.1	18.5	20.8	5.0
11.00	16.8	38.9	-17.7	-17.6	7.3	1.0	9.7	26.6	18.5	20.6	5.0
11.50	16.7	38.2	-16.5	-16.4	6.8	1.0	9.8	26.5	18.0	20.2	5.1
12.00	16.5	37.8	-15.2	-15.7	6.6	1.0	9.5	25.9	18.0	20.2	5.1
12.50	16.2	37.4	-14.3	-15.0	6.4	1.0	9.7	25.9	17.6	19.7	5.2
13.00	15.9	37.3	-14.1	-13.2	6.5	1.0	9.9	25.8	17.4	19.4	5.3
13.50	15.6	36.9	-14.4	-11.6	6.3	1.0	10.2	25.8	17.3	19.3	5.4
14.00	15.4	36.8	-15.1	-11.1	6.5	0.9	10.8	26.2	17.2	19.2	5.7
14.50	15.2	36.9	-15.9	-11.2	6.8	0.9	11.8	27.0	17.3	19.2	5.9
15.00	15.0	37.6	-16.7	-11.0	7.5	0.9	11.0	26.0	17.6	19.3	6.3
15.50	15.1	37.8	-17.7	-10.9	7.6	0.9	10.9	26.0	17.8	19.4	6.5
16.00	15.5	36.4	-19.1	-12.2	6.4	0.9	9.9	25.5	17.7	19.5	6.6
16.50	15.9	35.2	-19.1	-13.5	5.4	1.0	9.9	25.7	17.5	19.3	6.6
17.00	16.1	34.4	-17.5	-15.0	4.9	1.0	9.3	25.4	17.2	18.9	6.6
17.50	16.2	33.6	-15.9	-17.3	4.5	1.0	8.9	25.1	17.0	18.9	6.6
18.00	16.2	33.3	-16.1	-16.1	4.3	1.0	8.7	24.8	16.8	18.8	6.7
18.50	16.1	32.6	-17.1	-14.8	4.1	1.0	8.1	24.2	16.4	18.4	6.8
19.00	16.0	32.3	-16.1	-17.5	4.0	1.0	8.5	24.4	16.2	18.3	6.9
19.50	15.6	32.2	-14.2	-17.0	4.2	1.0	8.9	24.5	15.7	17.8	7.0
20.00	15.2	32.3	-14.1	-12.9	4.3	1.0	8.9	24.0	15.4	17.3	7.3
20.50	15.0	32.3	-16.4	-11.8	4.4	0.9	8.7	23.7	15.3	17.2	7.4
21.00	15.0	31.9	-19.5	-13.0	4.3	1.0	9.3	24.3	15.1	17.0	7.5
21.50	15.1	31.6	-20.4	-14.7	4.2	1.0	8.2	23.3	14.6	16.7	7.7
22.00	15.1	31.2	-17.9	-14.7	4.0	1.0	7.6	22.7	14.6	16.8	7.8
22.50	15.0	31.1	-15.2	-13.1	4.0	1.0	7.7	22.7	14.6	16.9	7.9
23.00	14.9	30.9	-14.3	-12.2	3.9	0.9	7.8	22.7	14.2	16.6	8.2
23.50	14.8	30.8	-15.3	-12.0	3.9	0.9	7.1	21.9	13.8	16.4	8.4
24.00	14.6	30.7	-18.2	-11.6	3.9	0.9	6.7	21.4	13.4	16.0	8.6
24.50	14.5	30.6	-22.7	-11.9	4.0	0.9	6.0	20.5	13.2	15.7	8.8
25.00	14.5	30.5	-23.5	-13.7	4.1	0.9	5.7	20.1	12.7	15.1	9.1
25.50	14.4	30.3	-22.8	-16.0	4.1	1.0	5.3	19.8	12.1	14.7	9.5
26.00	14.3	30.2	-21.4	-20.2	4.2	1.0	3.9	18.2	11.1	13.8	9.7
26.50	14.0	30.5	-16.2	-25.5	4.4	1.0	4.2	18.2	10.3	13.3	10.4
27.00	13.3	31.1	-13.7	-15.9	5.0	1.0	4.1	17.3	9.8	12.7	11.0
27.50	12.2	31.9	-13.9	-13.9	6.2	1.0	5.6	17.8	9.7	12.3	11.9
28.00	10.9	33.0	-14.3	-12.9	8.1	1.0	6.9	17.8	9.2	11.8	12.7
28.50	9.5	34.1	-13.0	-11.3	10.5	1.0	7.5	17.0	8.4	11.0	13.6
29.00	8.1	35.3	-11.8	-11.2	13.8	1.0	7.7	15.7	7.6	10.3	14.4
29.50	6.8	36.0	-11.4	-13.6	17.9	1.0	7.2	14.1	6.8	9.6	15.3
30.00	5.5	36.4	-11.7	-18.2	22.7	1.1	7.4	12.9	6.0	8.8	16.2

*Typical Performance Data*

**NOTE: Use PDF Bookmarks to view DATA at required conditions**

**Definitions:**

Input Return Loss = -S11 (dB)

Gain(Power Gain) = S21 (dB)

Reverse Isolation = -S12 (dB)

Output Return Loss = -S22 (dB)

TEST CONDITIONS: V<sub>CC</sub> = +5V, V<sub>B</sub> = +5.8V, V<sub>C</sub> = +5V, I<sub>CC</sub> = 104mA, I<sub>B</sub> = 5.9mA, I<sub>C</sub> = 1.5mA @ Temperature = +105°C

FREQ	Gain	Isolation	Input Return Loss	Output Return Loss	Stability		IP-3 Input	IP-3 Output	1dB Comp. Output	3dB Comp. Output	Noise Figure
					K	Measure					
(GHz)	(dB)	(dB)	(dB)	(dB)	K	Measure	(dBm)	(dBm)	(dBm)	(dBm)	(dB)
0.01	18.9	62.0	-16.8	-17.5	70.2	1.0	-	-	20.6	21.7	22.9
0.02	18.8	53.5	-16.7	-18.0	26.5	1.0	10.1	28.9	20.7	21.8	22.0
0.03	18.7	63.3	-16.4	-18.4	83.1	1.0	8.1	26.8	20.9	21.9	22.5
0.04	18.6	66.7	-16.5	-18.4	123.9	1.0	8.4	27.0	21.1	22.3	22.4
0.05	18.5	61.9	-16.4	-18.3	71.8	1.0	11.5	30.0	21.2	22.3	22.5
0.06	18.5	65.9	-16.4	-18.2	113.6	1.0	12.1	30.6	20.9	22.1	22.4
0.07	18.5	64.0	-16.4	-18.3	92.0	1.0	10.6	29.1	20.9	22.1	22.4
0.08	18.5	61.9	-16.4	-18.3	72.3	1.0	12.9	31.3	20.9	22.2	22.1
0.09	18.4	68.1	-16.4	-18.4	148.0	1.0	13.4	31.9	20.9	22.1	22.1
0.10	18.4	73.1	-16.4	-18.5	263.0	1.0	15.2	33.6	20.7	22.1	22.1
0.20	18.3	78.7	-16.7	-19.5	516.8	1.0	11.1	29.4	20.2	21.9	20.8
0.25	18.1	67.2	-17.1	-20.5	139.7	1.0	10.2	28.3	19.5	21.6	19.4
0.50	17.9	63.3	-16.2	-20.8	92.3	1.0	10.1	28.0	18.8	21.3	16.9
1.00	17.1	58.5	-14.6	-24.1	58.0	1.0	9.2	26.3	17.9	21.0	13.0
1.50	17.0	57.1	-14.7	-18.3	50.0	1.0	10.1	27.2	17.9	21.4	10.5
2.00	17.1	55.2	-14.8	-15.5	39.2	1.0	9.3	26.4	17.9	21.4	9.0
2.50	17.2	53.9	-14.5	-14.1	33.5	1.0	9.3	26.5	18.0	21.6	8.0
3.00	17.1	52.2	-13.7	-13.8	27.7	1.0	9.5	26.6	18.1	21.7	7.3
3.50	17.0	54.8	-12.9	-13.8	37.6	1.0	9.8	26.8	18.3	21.7	6.8
4.00	17.1	53.4	-12.9	-14.2	32.3	1.0	9.3	26.4	18.5	21.6	6.3
4.50	17.2	51.3	-13.4	-15.2	25.4	1.0	10.1	27.3	18.5	21.7	5.8
5.00	17.2	48.5	-13.9	-15.7	18.8	1.0	9.3	26.5	18.5	21.7	5.4
5.50	17.2	47.1	-14.3	-16.7	16.3	1.0	10.0	27.2	18.5	21.6	5.3
6.00	17.1	45.7	-14.7	-19.3	14.3	1.0	9.6	26.7	18.5	21.7	5.0
6.50	17.1	44.7	-15.4	-24.6	13.1	1.0	9.0	26.0	18.5	21.6	4.8
7.00	17.0	43.6	-15.8	-33.3	11.8	1.0	9.6	26.6	18.4	21.4	4.7
7.50	16.9	42.8	-16.2	-42.3	10.9	1.0	10.1	27.0	18.5	21.3	4.6
8.00	16.9	42.2	-16.9	-27.9	10.3	1.0	10.0	26.9	18.6	21.2	4.7
8.50	17.0	41.5	-19.0	-23.4	9.6	1.0	10.1	27.0	18.7	21.2	4.7
9.00	17.0	40.9	-23.5	-22.3	9.0	1.0	9.6	26.6	18.9	21.4	4.8
9.50	17.0	40.6	-27.5	-21.5	8.7	1.0	9.9	26.9	18.9	21.4	5.0
10.00	17.1	39.6	-21.9	-19.6	7.7	1.0	9.1	26.2	18.9	21.3	5.0
10.50	17.1	39.1	-19.1	-18.5	7.2	1.0	9.3	26.4	18.9	21.2	5.0
11.00	17.0	38.8	-17.6	-17.7	7.0	1.0	10.3	27.3	18.7	21.0	5.1
11.50	16.9	38.5	-16.5	-16.5	6.8	1.0	10.0	26.9	18.2	20.5	5.0
12.00	16.7	37.9	-15.3	-15.8	6.5	1.0	9.6	26.3	18.3	20.5	5.2
12.50	16.5	37.4	-14.3	-15.2	6.3	1.0	9.6	26.1	17.8	20.1	5.2
13.00	16.2	37.2	-14.1	-13.3	6.3	1.0	9.6	25.8	17.7	19.8	5.4
13.50	15.9	36.9	-14.4	-11.7	6.2	1.0	10.6	26.4	17.6	19.7	5.5
14.00	15.6	37.0	-15.1	-11.2	6.4	0.9	9.6	25.2	17.4	19.6	5.8
14.50	15.4	37.0	-15.9	-11.3	6.7	0.9	11.1	26.6	17.6	19.7	6.0
15.00	15.2	37.8	-16.7	-11.0	7.4	0.9	11.1	26.3	17.9	19.8	6.4
15.50	15.3	37.8	-17.7	-10.9	7.4	0.9	10.8	26.1	18.0	19.9	6.5
16.00	15.8	36.3	-19.2	-12.1	6.2	0.9	10.2	25.9	18.1	20.0	6.6
16.50	16.1	35.3	-19.1	-13.3	5.4	1.0	9.1	25.2	17.9	19.7	6.6
17.00	16.3	34.4	-17.5	-14.8	4.8	1.0	8.4	24.7	17.5	19.4	6.7
17.50	16.4	33.8	-16.0	-17.1	4.5	1.0	8.7	25.1	17.2	19.3	6.7
18.00	16.4	33.2	-16.1	-16.2	4.2	1.0	7.6	24.0	17.0	19.2	6.7
18.50	16.3	32.8	-17.0	-14.8	4.0	1.0	7.8	24.1	16.6	18.8	6.9
19.00	16.2	32.5	-16.1	-17.4	4.0	1.0	8.3	24.5	16.4	18.7	7.0
19.50	15.9	32.3	-14.1	-17.2	4.1	1.0	8.1	24.0	15.9	18.2	7.2
20.00	15.4	32.3	-14.0	-13.0	4.2	1.0	7.9	23.3	15.4	17.6	7.3
20.50	15.2	32.6	-16.3	-11.8	4.4	0.9	8.8	24.1	15.5	17.5	7.5
21.00	15.3	32.0	-19.5	-12.9	4.2	1.0	8.0	23.2	15.3	17.4	7.5
21.50	15.3	31.6	-20.5	-14.7	4.1	1.0	7.3	22.6	14.8	17.0	7.8
22.00	15.3	31.3	-18.0	-14.8	4.0	1.0	7.0	22.3	14.8	17.1	7.8
22.50	15.3	31.3	-15.3	-13.3	3.9	1.0	6.9	22.2	14.7	17.3	7.9
23.00	15.1	31.0	-14.3	-12.4	3.8	1.0	7.2	22.3	14.4	16.9	8.2
23.50	15.0	30.8	-15.3	-12.2	3.8	0.9	6.2	21.3	14.1	16.7	8.4
24.00	14.9	30.9	-18.2	-11.8	3.9	0.9	6.1	21.0	13.6	16.3	8.6
24.50	14.7	30.8	-22.6	-11.9	4.0	0.9	6.0	20.8	13.4	16.0	8.9
25.00	14.7	30.6	-23.3	-13.5	4.1	0.9	5.4	20.0	12.7	15.3	9.0
25.50	14.6	30.5	-22.6	-15.6	4.1	1.0	4.9	19.5	12.2	14.9	9.4
26.00	14.5	30.4	-21.6	-19.0	4.2	1.0	3.5	18.1	11.2	14.0	9.8
26.50	14.3	30.5	-16.5	-27.1	4.4	1.0	3.6	17.9	10.3	13.4	10.3
27.00	13.6	31.1	-13.8	-16.9	4.9	1.0	3.6	17.2	9.6	12.8	11.0
27.50	12.6	31.7	-13.9	-14.4	5.8	1.0	4.7	17.3	9.5	12.5	11.7
28.00	11.4	32.9	-14.1	-13.2	7.5	1.0	6.2	17.6	9.1	11.9	12.5
28.50	10.0	34.2	-12.9	-11.3	10.0	1.0	6.7	16.7	8.3	11.1	13.5
29.00	8.6	34.9	-11.7	-11.0	12.4	1.0	6.6	15.2	7.8	10.6	14.3
29.50	7.4	35.8	-11.2	-13.0	16.2	1.0	6.9	14.3	6.8	9.9	15.2
30.00	6.1	36.7	-11.6	-17.0	21.8	1.0	6.7	12.8	6.0	9.1	16.0



## Typical Performance Curves

Note: All data taken at nominal conditions  $V_{CC} = +5V$ ,  $V_C = +5V$ , and  $V_B = +5V$  unless noted otherwise.

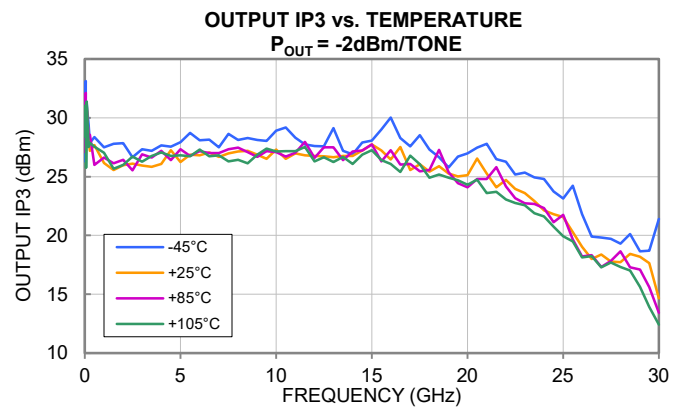
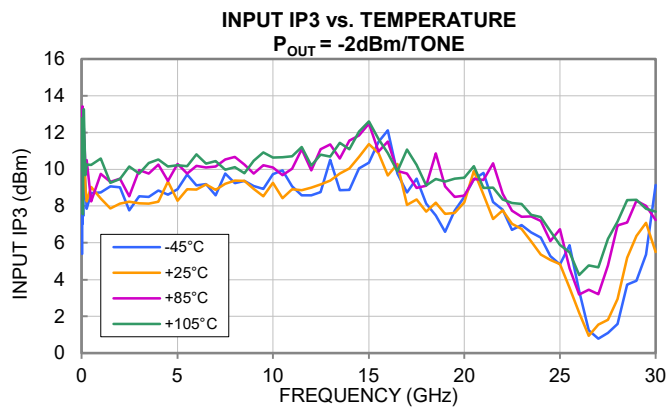
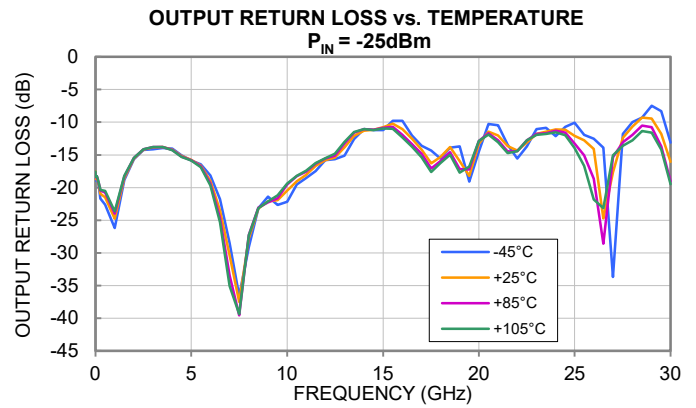
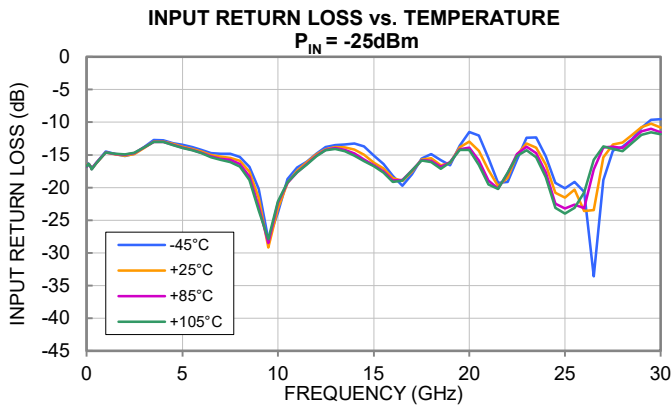
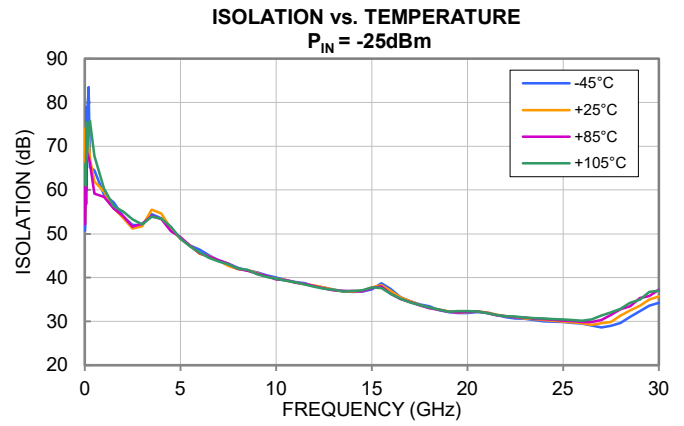
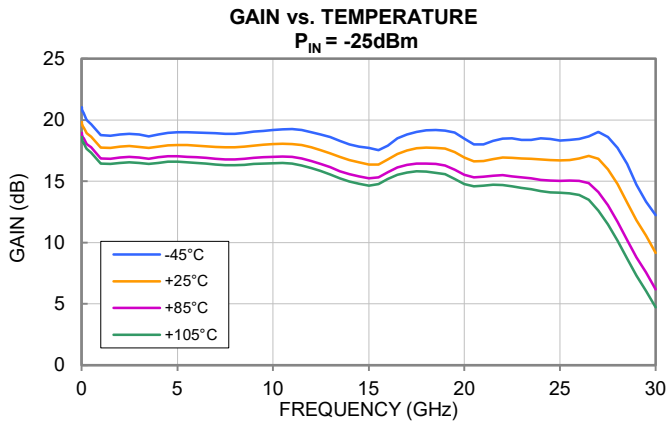

## Typical Performance Curves

Note: All data taken at nominal conditions  $V_{CC} = +5V$ ,  $V_C = +5V$ , and  $V_B = +5V$  unless noted otherwise.

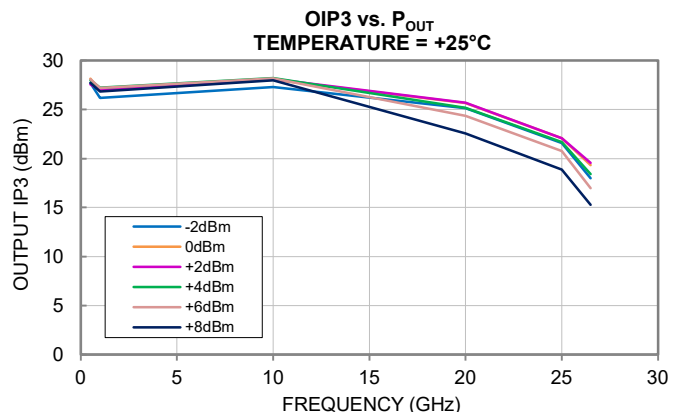
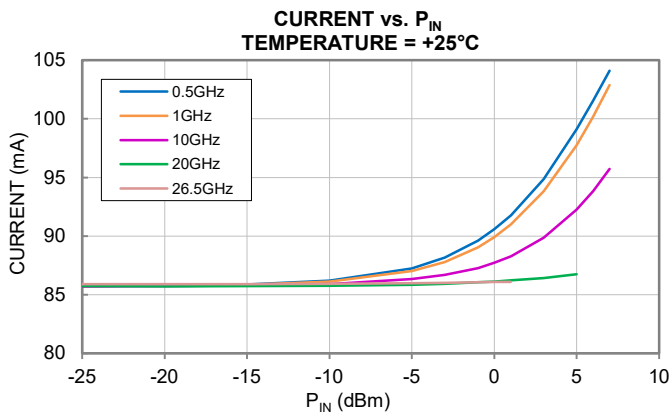
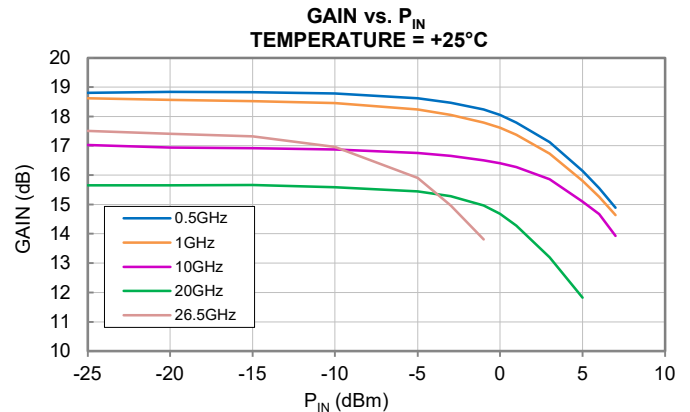
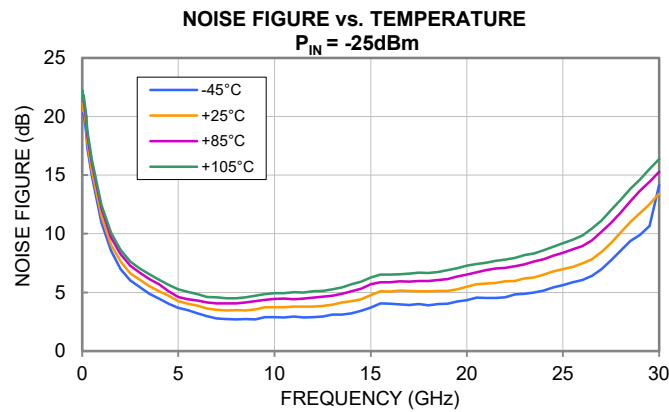
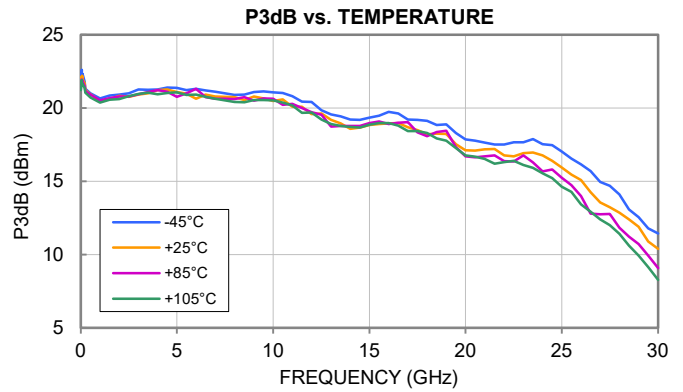
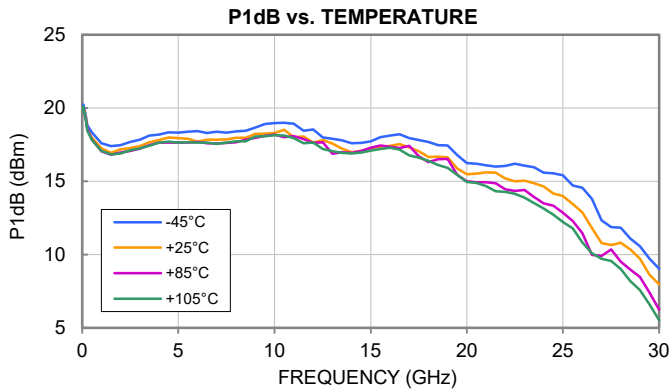

## Typical Performance Curves

Note: All data taken at nominal conditions  $V_{CC} = +5V$ ,  $V_C = +5V$ , and  $V_B = +5V$  unless noted otherwise.

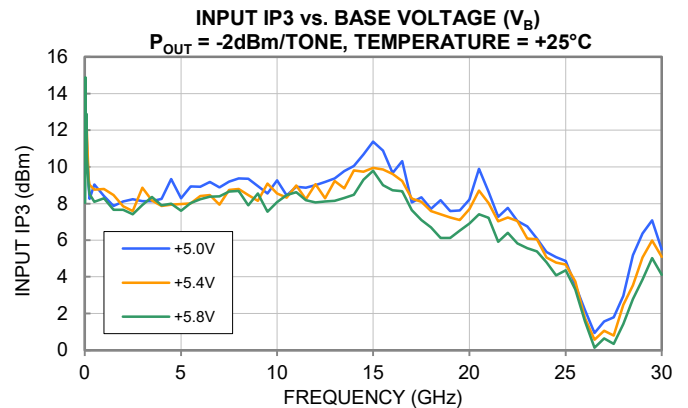
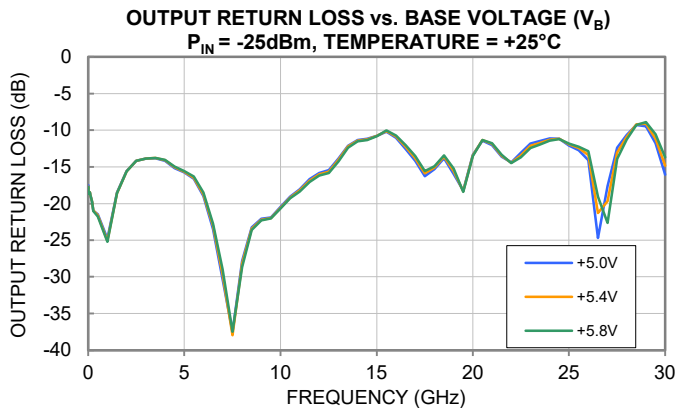
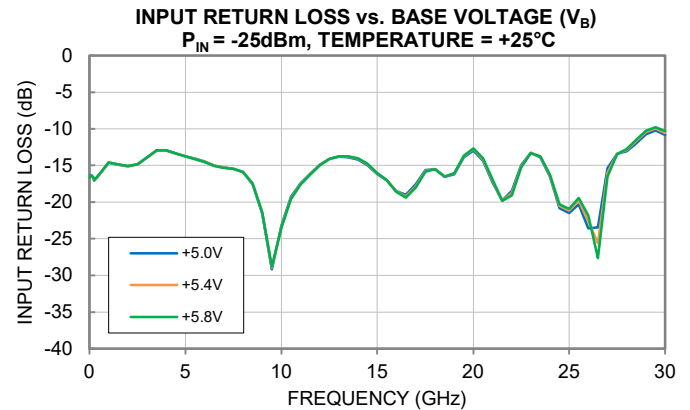
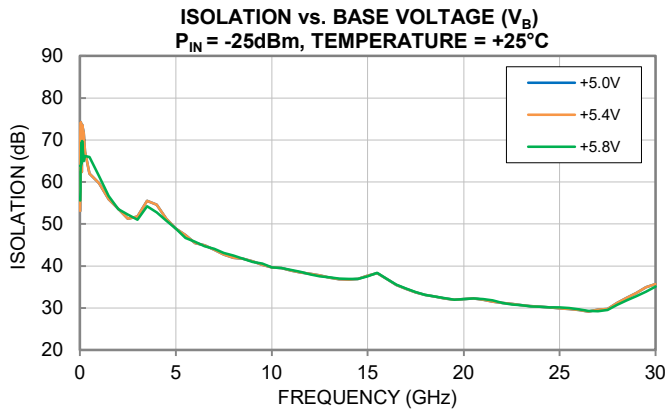
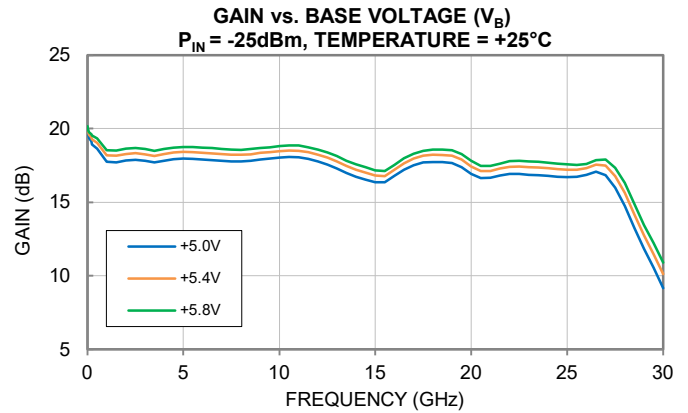
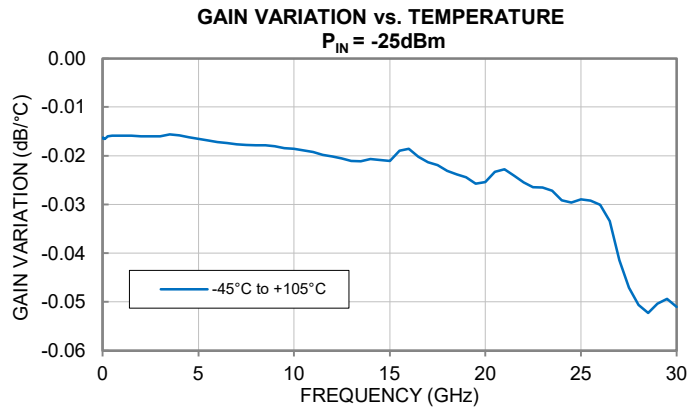

## Typical Performance Curves

Note: All data taken at nominal conditions  $V_{CC} = +5V$  and  $V_C = +5V$  unless noted otherwise.

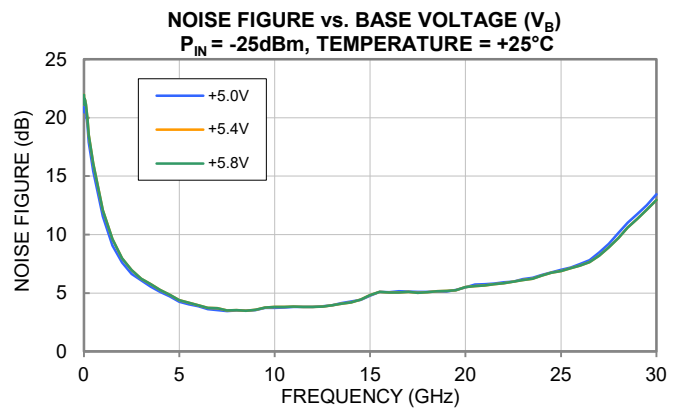
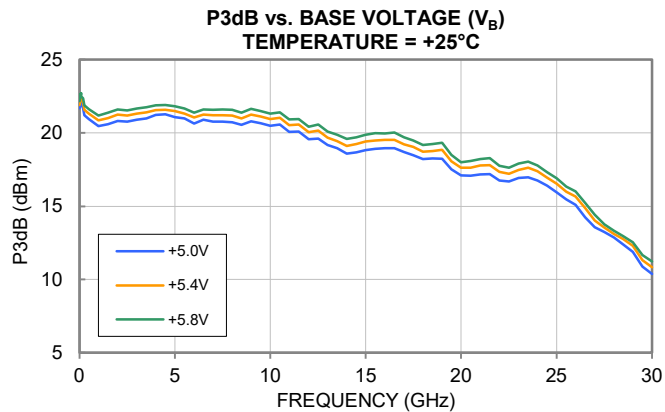
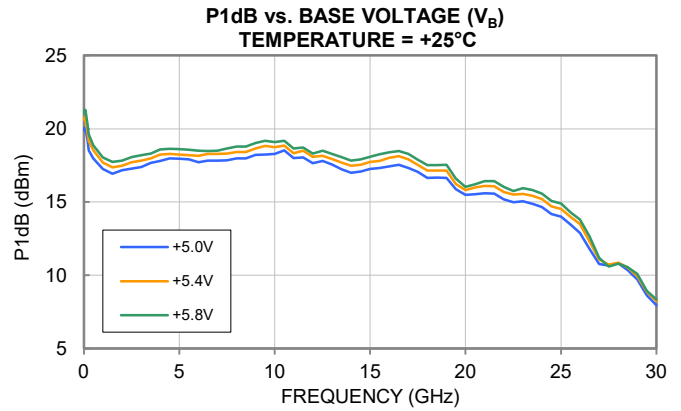
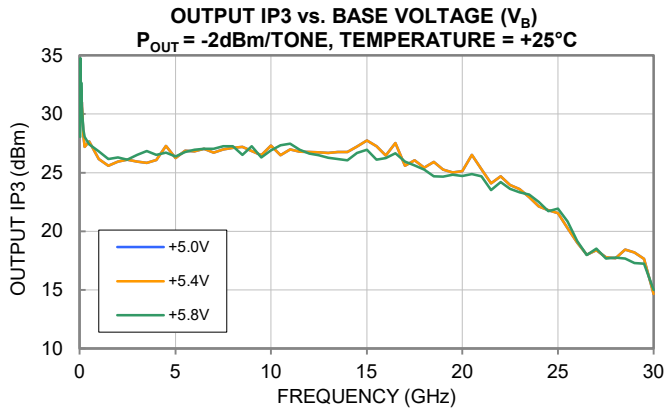

## Typical Performance Curves

Note: All data taken at nominal conditions  $V_{CC} = +5V$ ,  $V_C = +5V$ , and  $V_B = +5V$  unless noted otherwise.

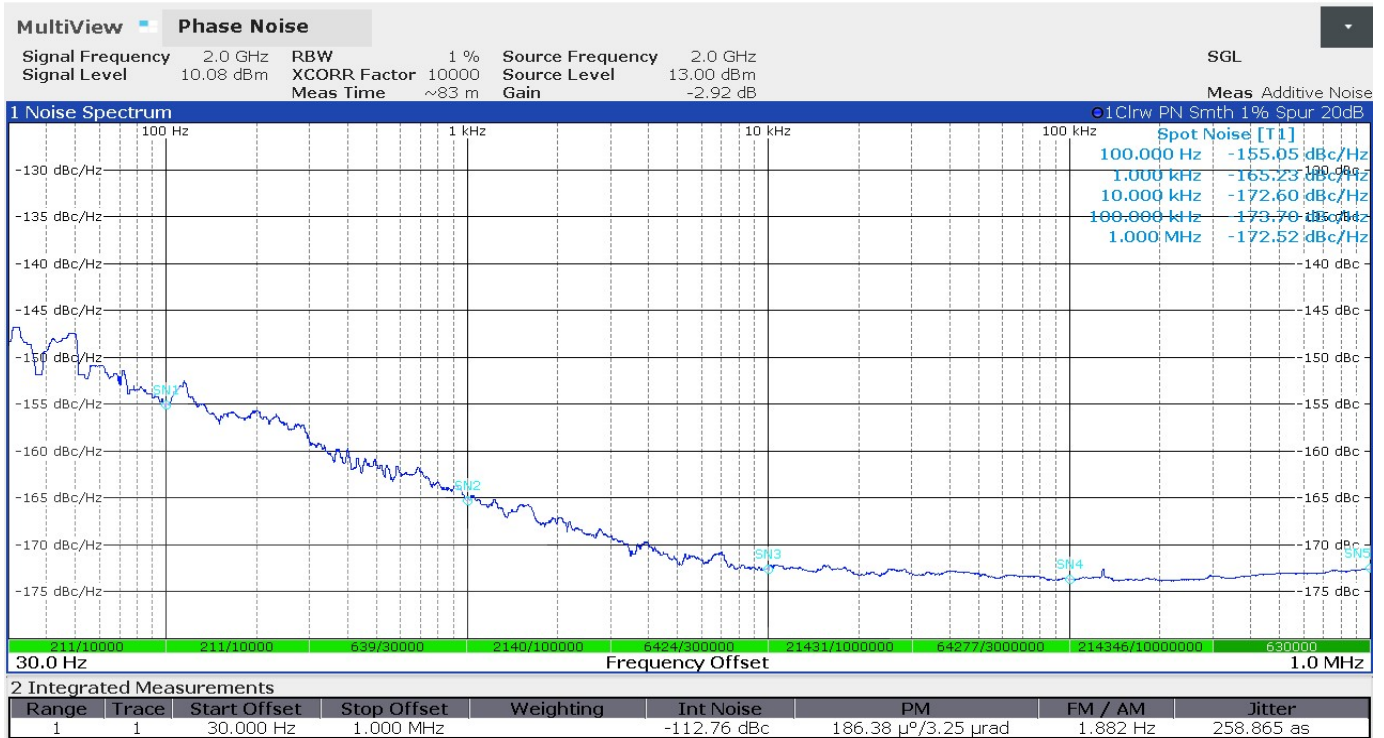

Note: Tested in a 4x4mm 24-lead QFN-style package.

All Mini-Circuits products are manufactured under exacting quality assurance and control standards, and are capable of meeting published specifications after being subjected to any or all of the following physical and environmental test.

Specification	Test/Inspection Condition	Reference/Spec
Operating Temperature	-40° to 85° C or -40° to 105° C or -55° to 105° C or -45° to 105° C Ambient Environment	Refer to Individual Model Data Sheet
Storage Environment (Die)	-65° to 150°C	Individual Model Data Sheet
Storage Environment(Packaging)	-40° to 70°C and 40 to 60% humidity (In Factory Shipped Package)	