

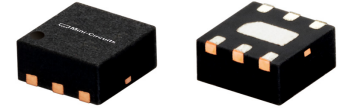

Monolithic Amplifier

THE BIG DEAL

- High IP3, +41 dBm typ. at 2 GHz, +5V
- Gain, 14.0 dB typ. at 2 GHz, 5V
- High P1 dB +22.5 dBm typ. at 2 GHz, +5V
- Low noise figure, 2.1 dB @2 GHz, +5V
- Usable to +4.0V
- No external matching components required



Generic photo used for illustration purposes only

CASE STYLE: MC1630-1

+RoHS Compliant

The +Suffix identifies RoHS Compliance. See our website for methodologies and qualifications

APPLICATIONS

- Base station infrastructure
- Portable Wireless
- CATV & DBS
- MMDS & Wireless LAN
- LTE

PRODUCT OVERVIEW

LHY-1H+ (RoHS compliant) is an advanced wideband amplifier fabricated using E-PHEMT technology and offers extremely high dynamic range over a broad frequency range and with low noise figure. In addition, the LHY-1H+, unlike competitive models, is well matched (input and output) over a broad frequency range without the need for external matching components. Lead finish is tin-silver over nickel. It is enclosed in a 2x2 mm MCLP package for low parasitic interface.

KEY FEATURES

Feature	Advantages
Broad Band: 0.05 to 6.0 GHz	Broadband covering primary wireless communications bands: Cellular, PCS, LTE, WiMAX
Extremely High IP3 versus DC power Consumption +41 dBm typical at 2 GHz	The LHY-1H+ matches industry leading IP3 performance relative to device size and power consumption. The combination of the design and E-PHEMT Structure provides enhanced linearity over a broad frequency range as evidence in the IP3 being typically 17 dB above the P 1dB point. This feature makes this amplifier ideal for use in: <ul style="list-style-type: none"> • Driver amplifiers for complex waveform up converter paths • Drivers in linearized transmit systems • Secondary amplifiers in ultra High Dynamic range receivers
Low Noise Figure: <ul style="list-style-type: none"> • 2.7 dB typ. up to 4 GHz • 3.1 dB typ. up to 6 GHz 	A unique feature of the LHY-1H+ which separates this design from all competitors is the low noise figure performance in combination with the high dynamic range.
Small size 2 x 2 mm	Saves PCB area

ELECTRICAL SPECIFICATIONS¹ AT 25°C, 50Ω, UNLESS NOTED OTHERWISE

Parameter	Condition (GHz)	Vd=+5.0V			Vd=+4.5V	Vd=+4.0V	Units
		Min.	Typ.	Max.	Typ.	Typ.	
Frequency Range		0.05		6	0.05-6	0.05-6	GHz
Gain	0.05	16.0	17.7	19.6	17.5	17.3	dB
	0.8	14.3	15.8	17.5	15.7	15.4	
	2.0	—	14.0	—	13.8	13.6	
	3.0	—	12.4	—	12.2	11.9	
	4.0	9.9	10.9	12.0	10.7	10.4	
	6.0	—	8.5	—	8.3	8.0	
Input Return Loss	0.05	—	11.1	—	11.0	10.6	dB
	0.8	12.5	15.5	—	15.3	14.9	
	2.0	—	10.9	—	10.8	10.6	
	3.0	—	9.2	—	9.1	8.9	
	4.0	—	7.8	—	7.7	7.6	
	6.0	—	6.7	—	6.7	6.7	
Output Return Loss	0.05	—	14.1	—	14.0	13.8	dB
	0.8	16.0	21.0	—	20.6	20.0	
	2.0	—	18.8	—	18.0	16.8	
	3.0	—	17.3	—	16.6	15.4	
	4.0	—	16.2	—	15.4	14.3	
	6.0	—	13.7	—	13.3	12.6	
Reverse Isolation	2.0	—	19.3	—	19.1	18.9	dB
Output Power @1 dB Compression	0.05	20.0	22.7	—	21.4	19.9	dBm
	0.8	20.0	22.6	—	21.4	19.9	
	2.0	20.0	22.5	—	21.3	19.8	
	3.0	—	22.8	—	21.5	19.9	
	4.0	—	22.7	—	21.5	20.0	
	6.0	—	22.3	—	21.2	19.7	
Output IP3	0.05	—	40.1	—	37.9	34.6	dBm
	0.8	37.0	40.0	—	39.7	35.1	
	2.0	—	41.0	—	36.3	33.0	
	3.0	—	41.6	—	36.2	32.6	
	4.0	—	40.8	—	35.7	32.2	
	6.0	—	39.4	—	35.4	31.9	
Noise Figure	0.05	—	1.6	—	1.5	1.4	dB
	0.8	—	1.8	—	1.7	1.7	
	2.0	—	2.1	—	2.0	2.0	
	3.0	—	2.3	—	2.3	2.2	
	4.0	—	2.6	—	2.4	2.4	
	6.0	—	3.1	—	3.1	2.8	
Device Operating Voltage		+4.8	+5.0	+5.2	+4.5	+4.0	V
Device Operating Current		—	144	165	116	88	mA
Device Current Variation vs. Temperature ²			113		136	152	μA/°C
Device Current Variation vs Voltage			0.059		0.057	0.056	mA/mV
Thermal Resistance, Junction-to-Ground Lead			55		55	55	°C/W

1. Measured on Mini-Circuits Characterization test board TB-621+. See Characterization Test Circuit (Fig. 1)

2. (Current at 85°C – Current at -45°C)/130

MAXIMUM RATINGS³

Parameter	Ratings
Operating Temperature (ground lead)	-40°C to 85°C
Storage Temperature	-65°C to 150°C
Operating Current at +5V	210 mA
Power Dissipation	1 W
Input Power (CW)	+24 dBm
DC Voltage on Pad 5	+6 V

3. Permanent damage may occur if any of these limits are exceeded.

Electrical maximum ratings are not intended for continuous normal operation.



ULTRA HIGH DYNAMIC RANGE

Monolithic Amplifier

LHY-1H+

SIMPLIFIED SCHEMATIC AND PAD DESCRIPTION



Function	Pad Number	Description
RF-IN	2	RF input pad
RF-OUT and DC-IN	5	RF output and bias pad
GND	1,3,4,6 paddle	Connections to ground.

CHARACTERIZATION TEST CIRCUIT

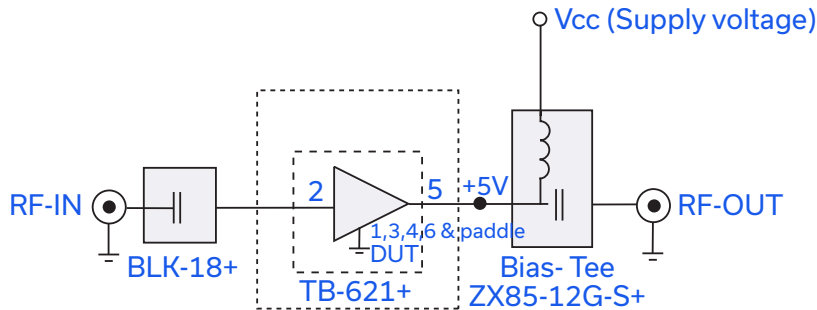

Fig 1. Block Diagram of Test Circuit used for characterization. (DUT soldered on Mini-Circuits Characterization test board TB-621+)
 Gain, Return loss, Output power at 1dB compression (P1 dB) , output IP3 (OIP3) and noise figure measured using Agilent's N5242A PNA-X microwave network analyzer.

Conditions:

1. Gain and Return loss: Pin= -25dBm
2. Output IP3 (OIP3): Two tones, spaced 1 MHz apart, 5 dBm/tone at output.



RECOMMENDED APPLICATION CIRCUIT

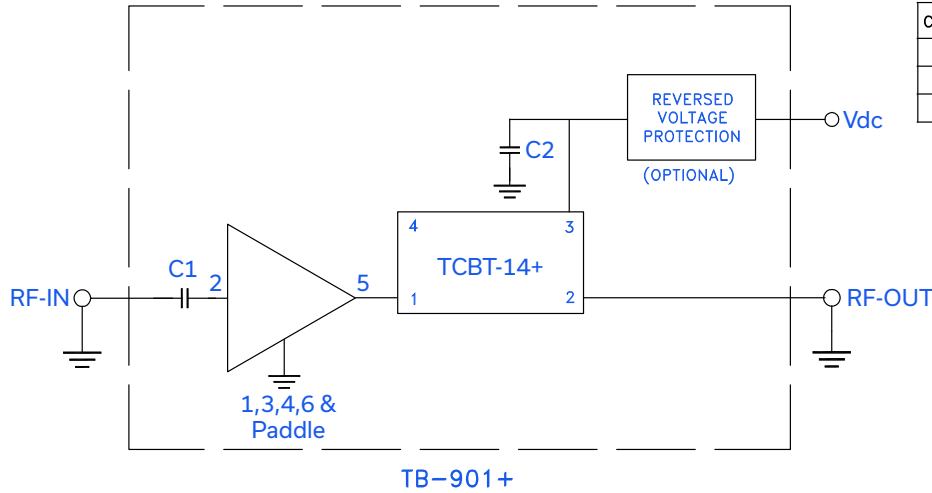

COMPONENT	SIZE	VALUE	P/N	MANUFACTURER
C1	0402	1nF	-	VARIOUS
C2	0805	1nF	-	VARIOUS
BIAS-TEE	-	-	TCBT-14+	MINI-CIRCUITS

Fig 2. Test Board includes case, connectors, and components soldered to PCB.

PRODUCT MARKING

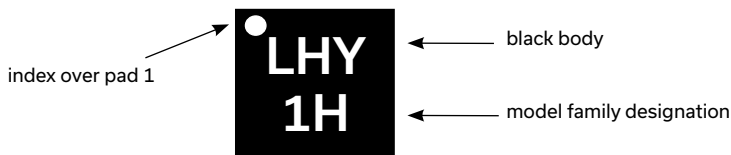

Marking may contain other features or characters for internal lot control



ULTRA HIGH DYNAMIC RANGE

Monolithic Amplifier

LHY-1H+

ADDITIONAL DETAILED TECHNICAL INFORMATION IS AVAILABLE ON OUR DASH BOARD. TO ACCESS [CLICK HERE](#)

Performance Data	Data Table Swept Graphs S-Parameter (S2P Files) Data Set (.zip file)
Case Style	MC1630-1 (2x2 mm MCLP) Plastic package, exposed paddle lead finish: tin-silver over nickel
Tape & Reel Standard quantities available on reel	F66 7" reels with 20, 50, 100, 200, 500, 1K, or 2K devices.
Suggested Layout for PCB Design	PL-493
Evaluation Board	TB-901+
Environmental Ratings	ENV08T1

ESD RATING

Human Body Model (HBM): Class 1B (500 to <1000V) in accordance with ANSI/ESD STM 5.1 - 2001
Machine Model (MM): Class M1 (>25V) in accordance with ANSI/ESD STM5.2-1999

MSL RATING

Moisture Sensitivity: MSL1 in accordance with IPC/JEDEC J-STD-020D

MSL TEST FLOW CHART

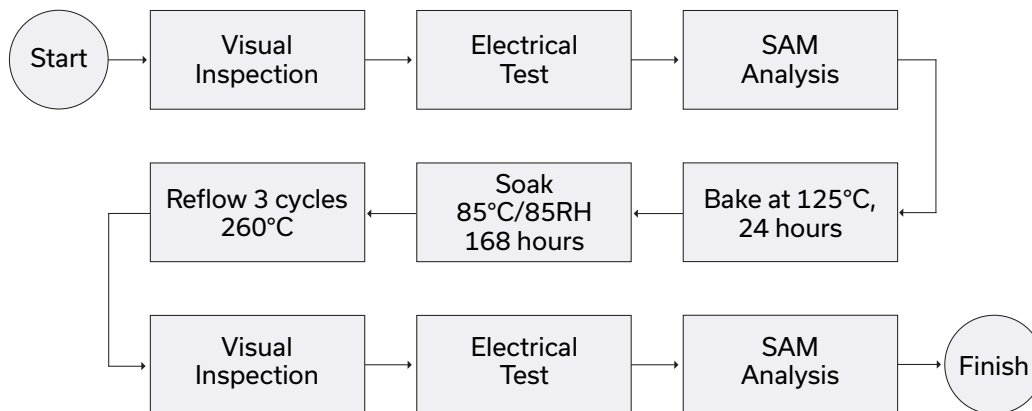

- NOTES**
- A. Performance and quality attributes and conditions not expressly stated in this specification document are intended to be excluded and do not form a part of this specification document.
 - B. Electrical specifications and performance data contained in this specification document are based on Mini-Circuit's applicable established test performance criteria and measurement instructions.
 - C. The parts covered by this specification document are subject to Mini-Circuits standard limited warranty and terms and conditions (collectively, "Standard Terms"); Purchasers of this part are entitled to the rights and benefits contained therein. For a full statement of the standard. Terms and the exclusive rights and remedies thereunder, please visit Mini-Circuits' website at www.minicircuits.com/MCLStore/terms.jsp



Typical Performance Data

Definitions:

Input Return Loss = -S11 (dB)

Gain(Power Gain) = S21 (dB)

Reverse Isolation = -S12 (dB)

Output Return Loss = -S22 (dB)

TEST CONDITIONS: Vd = 5V, Id = 143.15 mA @ Temperature = +25degC

FREQ	Gain	Isolation	Input Return Loss	Output Return Loss	Stability		IP-3 Output	1dB Comp. Output	Noise Figure
					K	Measure			
(MHz)	(dB)	(dB)	(dB)	(dB)	K	Measure	(dBm)	(dBm)	(dB)
20	19.66	23.71	7.21	9.82	0.88	0.69	40.54	21.43	1.54
30	18.88	22.43	8.90	11.48	0.90	0.66	40.80	22.29	1.56
40	18.28	21.78	10.48	12.98	0.94	0.65	40.39	22.65	1.51
50	17.86	21.50	11.77	14.18	0.97	0.64	39.56	23.10	1.55
60	17.56	21.21	13.04	15.34	1.00	0.63	40.20	22.26	1.61
70	17.35	21.12	14.11	16.29	1.02	0.63	40.39	22.26	1.56
80	17.20	20.99	14.98	17.09	1.03	0.63	40.51	22.37	1.63
90	17.08	20.92	15.72	17.69	1.04	0.62	40.16	22.41	1.63
100	17.00	20.87	16.36	18.26	1.05	0.62	41.15	22.52	1.63
200	16.66	20.69	19.67	21.04	1.09	0.62	40.87	22.48	1.62
400	16.46	20.62	19.90	21.93	1.10	0.63	40.95	22.33	1.76
600	16.27	20.54	18.46	21.61	1.10	0.64	41.21	22.46	1.81
800	16.05	20.43	16.98	21.13	1.10	0.66	40.47	22.39	1.75
1000	15.79	20.31	15.64	20.66	1.10	0.68	41.52	22.54	1.82
1200	15.51	20.17	14.54	20.14	1.09	0.70	41.08	22.49	1.92
1400	15.20	19.98	13.56	19.85	1.09	0.72	42.00	22.56	1.90
1600	14.88	19.82	12.73	19.58	1.09	0.75	42.51	22.61	1.98
1800	14.54	19.63	12.05	19.37	1.09	0.77	41.73	22.48	2.02
2000	14.20	19.41	11.44	19.30	1.08	0.79	42.07	22.71	2.05
2200	13.85	19.20	10.87	19.34	1.08	0.81	43.75	23.00	2.10
2600	13.17	18.75	9.92	19.61	1.08	0.85	43.03	22.77	2.25
2800	12.83	18.52	9.50	20.00	1.07	0.86	42.40	22.78	2.28
3000	12.49	18.28	9.14	20.34	1.07	0.88	42.45	22.80	2.29
3200	12.17	18.04	8.80	20.84	1.07	0.90	42.51	22.81	2.45
3400	11.85	17.79	8.47	21.52	1.07	0.91	42.68	22.87	2.54
3600	11.54	17.55	8.16	22.04	1.06	0.92	42.86	22.90	2.60
3800	11.23	17.30	7.92	22.65	1.06	0.93	42.65	22.90	2.62
4000	10.94	17.04	7.66	23.13	1.06	0.94	43.10	22.94	2.66
4200	10.66	16.81	7.43	23.21	1.05	0.95	42.46	22.75	2.72
4400	10.38	16.56	7.23	23.26	1.05	0.96	41.88	22.60	2.75
4600	10.11	16.32	7.04	22.92	1.04	0.97	41.09	22.50	2.85
4800	9.85	16.08	6.89	22.08	1.04	0.98	41.61	22.48	2.93
5000	9.60	15.82	6.77	21.36	1.03	0.98	40.36	21.82	2.97
5200	9.35	15.59	6.67	20.50	1.03	0.98	40.78	22.30	2.99
5400	9.11	15.34	6.58	19.52	1.02	0.98	41.76	22.30	3.16
5600	8.88	15.11	6.51	18.58	1.01	0.99	39.99	21.72	3.11
5800	8.66	14.86	6.48	17.56	1.00	0.98	40.17	21.80	3.18
6000	8.44	14.64	6.48	16.60	1.00	0.98	40.17	21.53	3.24
6200	8.24	14.39	6.46	15.77	0.99	0.98	39.72	21.52	3.27
6400	8.03	14.14	6.48	14.85	0.98	0.97	39.81	21.59	3.30
6600	7.84	13.91	6.53	13.98	0.97	0.96	39.72	21.50	3.32
6800	7.63	13.68	6.60	13.26	0.96	0.95	38.88	21.43	3.43
7000	7.44	13.45	6.65	12.42	0.95	0.94	38.85	21.40	3.38

Typical Performance Data

Definitions:

Input Return Loss = -S11 (dB)

Gain(Power Gain) = S21 (dB)

Reverse Isolation = -S12 (dB)

Output Return Loss = -S22 (dB)

TEST CONDITIONS: Vd = 4.5V, Id =113.39 mA @ Temperature = +25degC

FREQ	Gain	Isolation	Input Return Loss	Output Return Loss	Stability		IP-3 Output	1dB Comp. Output	Noise Figure
					K	Measure			
(MHz)	(dB)	(dB)	(dB)	(dB)	K	Measure	(dBm)	(dBm)	(dB)
20	19.53	23.78	7.04	9.70	0.88	0.71	37.65	20.27	1.40
30	18.75	22.40	8.68	11.32	0.89	0.68	38.57	21.16	1.44
40	18.14	21.71	10.21	12.78	0.93	0.66	38.34	21.47	1.41
50	17.72	21.45	11.50	14.04	0.97	0.66	37.58	21.84	1.46
60	17.41	21.07	12.76	15.14	0.99	0.64	38.54	21.08	1.50
70	17.19	20.98	13.82	16.10	1.02	0.64	39.01	21.08	1.48
80	17.03	20.85	14.68	16.85	1.03	0.63	39.43	21.20	1.52
90	16.91	20.79	15.45	17.50	1.04	0.63	39.76	21.21	1.53
100	16.82	20.72	16.06	18.07	1.05	0.63	40.44	21.34	1.53
200	16.47	20.54	19.38	20.79	1.09	0.62	43.28	21.30	1.52
400	16.26	20.46	19.67	21.57	1.10	0.63	45.49	21.15	1.72
600	16.08	20.38	18.29	21.10	1.10	0.65	42.92	21.31	1.76
800	15.85	20.29	16.84	20.54	1.10	0.67	40.69	21.25	1.70
1000	15.60	20.15	15.52	19.93	1.09	0.68	40.65	21.39	1.78
1200	15.31	19.99	14.43	19.34	1.09	0.70	39.36	21.35	1.84
1400	15.00	19.82	13.48	19.01	1.09	0.73	39.03	21.39	1.80
1600	14.68	19.64	12.66	18.70	1.08	0.75	39.53	21.45	1.90
1800	14.34	19.42	11.98	18.48	1.08	0.77	38.24	21.33	1.92
2000	14.00	19.22	11.38	18.39	1.08	0.79	38.05	21.54	1.96
2200	13.65	19.00	10.82	18.40	1.08	0.81	38.82	21.78	2.01
2600	12.97	18.56	9.89	18.66	1.07	0.85	37.99	21.58	2.17
2800	12.63	18.31	9.48	19.01	1.07	0.86	37.72	21.61	2.18
3000	12.30	18.08	9.13	19.33	1.07	0.88	37.69	21.58	2.19
3200	11.98	17.84	8.78	19.79	1.06	0.89	37.45	21.63	2.33
3400	11.66	17.61	8.46	20.37	1.06	0.91	37.52	21.67	2.40
3600	11.35	17.36	8.17	20.78	1.06	0.92	37.62	21.75	2.43
3800	11.05	17.13	7.91	21.25	1.06	0.93	37.40	21.72	2.48
4000	10.76	16.87	7.67	21.56	1.05	0.94	37.46	21.81	2.54
4200	10.47	16.63	7.44	21.51	1.05	0.95	37.15	21.62	2.61
4400	10.20	16.39	7.24	21.50	1.05	0.96	36.49	21.43	2.60
4600	9.93	16.15	7.07	21.11	1.04	0.97	36.45	21.38	2.67
4800	9.67	15.91	6.92	20.38	1.03	0.97	36.77	21.41	2.74
5000	9.42	15.68	6.80	19.74	1.03	0.98	35.27	20.85	2.74
5200	9.18	15.45	6.70	19.03	1.03	0.98	36.39	21.18	2.86
5400	8.94	15.20	6.62	18.19	1.02	0.98	36.73	21.16	2.90
5600	8.70	14.97	6.56	17.39	1.01	0.98	35.37	20.67	2.92
5800	8.49	14.73	6.53	16.48	1.00	0.98	35.56	20.74	2.97
6000	8.27	14.52	6.54	15.67	1.00	0.97	35.41	20.49	3.04
6200	8.07	14.27	6.52	14.94	0.99	0.97	35.16	20.51	3.05
6400	7.86	14.04	6.55	14.11	0.98	0.96	35.38	20.53	3.02
6600	7.67	13.81	6.60	13.35	0.97	0.95	35.13	20.47	3.08
6800	7.46	13.59	6.68	12.70	0.97	0.94	34.70	20.39	3.21
7000	7.27	13.38	6.74	11.93	0.96	0.92	34.42	20.39	3.20

Typical Performance Data

NOTE: Use PDF Bookmarks to view DATA at required conditions

Definitions:

Input Return Loss = -S11 (dB)

Gain(Power Gain) = S21 (dB)

Reverse Isolation = -S12 (dB)

Output Return Loss = -S22 (dB)

TEST CONDITIONS: Vd = 4.75V, Id = 128.26 mA @ Temperature = +25degC

FREQ	Gain	Isolation	Input Return Loss	Output Return Loss	Stability		IP-3 Output	1dB Comp. Output	Noise Figure
					K	Measure			
(MHz)	(dB)	(dB)	(dB)	(dB)	K	Measure	(dBm)	(dBm)	(dB)
20	19.61	23.76	7.14	9.77	0.88	0.70	38.43	20.86	1.48
30	18.83	22.44	8.81	11.43	0.90	0.67	40.02	21.75	1.49
40	18.23	21.77	10.36	12.89	0.93	0.65	39.91	22.07	1.46
50	17.80	21.30	11.66	14.15	0.96	0.63	39.02	22.50	1.49
60	17.50	21.16	12.90	15.25	1.00	0.63	39.62	21.72	1.55
70	17.28	21.01	13.97	16.20	1.02	0.63	39.87	21.71	1.52
80	17.13	20.95	14.84	16.96	1.03	0.63	40.04	21.79	1.58
90	17.01	20.84	15.60	17.62	1.04	0.62	40.17	21.85	1.58
100	16.92	20.80	16.23	18.17	1.05	0.62	41.37	21.94	1.57
200	16.58	20.66	19.56	20.89	1.09	0.62	41.65	21.91	1.55
400	16.38	20.54	19.82	21.72	1.10	0.63	42.28	21.77	1.75
600	16.19	20.44	18.39	21.34	1.10	0.64	41.80	21.91	1.80
800	15.96	20.35	16.94	20.85	1.10	0.66	40.85	21.86	1.72
1000	15.71	20.25	15.60	20.31	1.10	0.68	41.66	21.99	1.79
1200	15.43	20.10	14.50	19.77	1.09	0.70	40.76	21.95	1.88
1400	15.12	19.92	13.54	19.48	1.09	0.72	40.88	22.02	1.85
1600	14.80	19.73	12.72	19.17	1.09	0.75	41.51	22.06	1.91
1800	14.45	19.53	12.03	18.99	1.08	0.77	40.34	21.94	1.99
2000	14.12	19.33	11.42	18.91	1.08	0.79	40.59	22.17	2.01
2200	13.77	19.11	10.85	18.93	1.08	0.81	41.29	22.39	2.05
2600	13.09	18.66	9.91	19.22	1.07	0.85	40.53	22.20	2.20
2800	12.75	18.43	9.50	19.59	1.07	0.86	40.12	22.22	2.26
3000	12.41	18.19	9.15	19.92	1.07	0.88	40.11	22.22	2.23
3200	12.09	17.95	8.79	20.41	1.07	0.89	39.95	22.29	2.39
3400	11.77	17.71	8.47	21.04	1.07	0.91	40.04	22.33	2.46
3600	11.46	17.47	8.17	21.50	1.06	0.92	40.07	22.35	2.51
3800	11.16	17.22	7.92	22.06	1.06	0.93	39.95	22.34	2.56
4000	10.87	16.97	7.67	22.46	1.06	0.94	40.11	22.42	2.59
4200	10.58	16.74	7.44	22.48	1.05	0.95	39.47	22.23	2.67
4400	10.31	16.50	7.24	22.50	1.05	0.96	38.85	22.06	2.67
4600	10.04	16.25	7.06	22.10	1.04	0.97	38.63	21.95	2.74
4800	9.78	16.01	6.91	21.31	1.04	0.97	39.27	21.95	2.81
5000	9.52	15.77	6.79	20.63	1.03	0.98	37.53	21.34	2.87
5200	9.28	15.53	6.69	19.86	1.03	0.98	38.61	21.77	2.92
5400	9.04	15.29	6.60	18.92	1.02	0.98	39.24	21.73	3.01
5600	8.81	15.04	6.54	18.04	1.01	0.98	37.58	21.19	3.02
5800	8.59	14.81	6.50	17.08	1.00	0.98	37.69	21.33	3.04
6000	8.37	14.58	6.51	16.19	1.00	0.98	37.67	21.02	3.16
6200	8.17	14.33	6.49	15.41	0.99	0.97	37.26	21.07	3.15
6400	7.96	14.10	6.51	14.52	0.98	0.96	37.46	21.12	3.16
6600	7.77	13.87	6.56	13.71	0.97	0.95	37.21	20.98	3.20
6800	7.56	13.64	6.64	13.01	0.96	0.94	36.74	20.92	3.31
7000	7.37	13.42	6.69	12.21	0.95	0.93	36.51	20.93	3.28

Typical Performance Data

Definitions:

Input Return Loss = -S11 (dB)

Gain(Power Gain) = S21 (dB)

Reverse Isolation = -S12 (dB)

Output Return Loss = -S22 (dB)

TEST CONDITIONS: Vd = 5.25V, Id = 157.95 mA @ Temperature = +25degC

FREQ	Gain	Isolation	Input Return Loss	Output Return Loss	Stability		IP-3 Output	1dB Comp. Output	Noise Figure
					K	Measure			
(MHz)	(dB)	(dB)	(dB)	(dB)	K	Measure	(dBm)	(dBm)	(dB)
20	19.69	23.76	7.32	9.88	0.88	0.69	39.81	21.94	1.64
30	18.90	22.51	9.02	11.55	0.90	0.67	40.31	22.77	1.63
40	18.31	21.82	10.59	13.05	0.94	0.65	41.87	23.17	1.58
50	17.90	21.34	11.89	14.34	0.97	0.62	40.45	23.55	1.60
60	17.61	21.24	13.16	15.45	1.00	0.63	40.35	22.74	1.69
70	17.39	21.11	14.22	16.42	1.02	0.63	40.95	22.76	1.63
80	17.25	21.03	15.08	17.19	1.03	0.62	40.84	22.89	1.69
90	17.13	20.96	15.84	17.86	1.05	0.62	40.18	22.90	1.70
100	17.05	20.89	16.47	18.40	1.05	0.62	40.95	23.00	1.67
200	16.72	20.75	19.77	21.21	1.09	0.62	40.90	22.98	1.62
400	16.52	20.68	19.95	22.10	1.10	0.63	40.45	22.82	1.84
600	16.33	20.60	18.49	21.83	1.10	0.64	40.77	22.94	1.89
800	16.11	20.50	16.99	21.42	1.10	0.66	40.31	22.87	1.82
1000	15.86	20.38	15.64	20.94	1.10	0.68	41.11	23.01	1.92
1200	15.57	20.23	14.53	20.42	1.09	0.70	41.39	22.97	1.98
1400	15.26	20.06	13.56	20.16	1.09	0.72	42.13	23.05	1.95
1600	14.94	19.88	12.74	19.88	1.09	0.75	43.16	23.10	2.02
1800	14.60	19.69	12.04	19.67	1.09	0.77	42.43	22.95	2.09
2000	14.26	19.48	11.42	19.59	1.08	0.79	43.54	23.21	2.12
2200	13.91	19.27	10.86	19.61	1.08	0.81	46.09	23.51	2.18
2600	13.22	18.82	9.91	19.89	1.08	0.85	46.76	23.25	2.32
2800	12.89	18.58	9.49	20.28	1.08	0.86	45.13	23.28	2.37
3000	12.55	18.34	9.13	20.61	1.07	0.88	45.83	23.25	2.38
3200	12.22	18.09	8.77	21.14	1.07	0.90	46.42	23.28	2.51
3400	11.90	17.85	8.45	21.85	1.07	0.91	46.89	23.36	2.62
3600	11.59	17.60	8.15	22.36	1.06	0.92	46.56	23.39	2.70
3800	11.29	17.36	7.89	23.08	1.06	0.94	46.19	23.39	2.74
4000	10.99	17.10	7.64	23.62	1.06	0.95	46.23	23.44	2.78
4200	10.71	16.87	7.41	23.73	1.05	0.96	45.81	23.27	2.81
4400	10.43	16.62	7.20	23.87	1.05	0.97	45.08	23.04	2.86
4600	10.16	16.37	7.02	23.52	1.04	0.97	44.86	22.95	2.96
4800	9.90	16.12	6.87	22.66	1.03	0.98	45.63	22.95	3.02
5000	9.64	15.87	6.74	21.91	1.03	0.98	44.05	22.27	3.09
5200	9.40	15.64	6.64	21.02	1.02	0.99	43.95	22.75	3.15
5400	9.16	15.39	6.55	19.99	1.02	0.99	45.68	22.74	3.22
5600	8.93	15.14	6.49	18.97	1.01	0.99	43.09	22.14	3.25
5800	8.71	14.91	6.45	17.90	1.00	0.99	42.46	22.23	3.28
6000	8.49	14.66	6.45	16.93	0.99	0.98	43.74	21.98	3.38
6200	8.29	14.40	6.42	16.04	0.98	0.98	42.78	21.98	3.38
6400	8.08	14.18	6.44	15.08	0.97	0.97	42.35	21.96	3.38
6600	7.88	13.94	6.49	14.19	0.96	0.96	42.18	21.84	3.47
6800	7.68	13.71	6.56	13.43	0.96	0.95	41.60	21.77	3.57
7000	7.49	13.48	6.61	12.57	0.95	0.94	41.71	21.79	3.52

Typical Performance Data

Definitions:

Input Return Loss = -S11 (dB)

Gain(Power Gain) = S21 (dB)

Reverse Isolation = -S12 (dB)

Output Return Loss = -S22 (dB)

TEST CONDITIONS: Vd = 5V, Id = 131.90 mA @ Temperature = -45degC

FREQ	Gain	Isolation	Input Return Loss	Output Return Loss	Stability		IP-3 Output	1dB Comp. Output	Noise Figure
					K	Measure			
(MHz)	(dB)	(dB)	(dB)	(dB)	K	Measure	(dBm)	(dBm)	(dB)
20	19.79	23.76	6.84	9.28	0.84	0.69	41.34	21.43	1.42
30	18.95	22.28	8.37	10.64	0.85	0.66	41.84	22.29	1.31
40	18.27	21.50	9.81	11.86	0.89	0.64	40.24	22.61	1.19
50	17.76	21.10	11.01	12.91	0.92	0.64	39.07	22.99	1.20
60	17.39	20.80	12.25	13.84	0.96	0.63	38.52	22.21	1.23
70	17.11	20.65	13.29	14.67	0.98	0.62	38.45	22.25	1.20
80	16.91	20.49	14.15	15.32	1.00	0.61	38.14	22.32	1.29
90	16.75	20.44	14.94	15.91	1.02	0.61	37.23	22.38	1.27
100	16.64	20.35	15.56	16.43	1.03	0.61	38.00	22.52	1.26
200	16.19	20.15	19.52	18.85	1.08	0.61	36.86	22.47	1.24
400	15.96	20.08	20.88	18.64	1.09	0.61	36.39	22.33	1.43
600	15.80	20.01	19.35	18.90	1.10	0.62	36.51	22.53	1.49
800	15.62	19.93	18.24	19.16	1.10	0.64	36.22	22.49	1.39
1000	15.42	19.84	16.80	19.71	1.10	0.66	37.12	22.66	1.46
1200	15.19	19.71	15.93	19.57	1.10	0.67	36.80	22.63	1.54
1400	14.93	19.57	14.84	19.48	1.10	0.69	37.64	22.68	1.49
1600	14.66	19.43	13.93	19.84	1.10	0.71	37.87	22.70	1.55
1800	14.37	19.26	13.15	20.11	1.10	0.73	37.62	22.59	1.60
2000	14.08	19.09	12.47	20.50	1.10	0.75	38.67	22.78	1.63
2200	13.78	18.90	11.84	20.85	1.10	0.77	39.82	23.04	1.65
2600	13.16	18.50	10.74	21.05	1.09	0.80	39.53	22.82	1.75
2800	12.86	18.30	10.28	21.72	1.09	0.82	39.76	22.84	1.77
3000	12.56	18.07	9.91	22.15	1.09	0.83	40.16	22.82	1.76
3200	12.27	17.85	9.55	23.07	1.09	0.85	40.13	22.87	1.91
3400	11.97	17.64	9.11	24.29	1.08	0.86	40.55	22.92	1.98
3600	11.68	17.41	8.73	24.45	1.08	0.88	40.26	22.92	1.98
3800	11.40	17.16	8.48	25.00	1.07	0.89	40.81	22.96	2.05
4000	11.13	16.95	8.18	25.60	1.07	0.90	40.87	23.03	2.06
4200	10.87	16.70	7.90	26.45	1.06	0.91	40.65	22.94	2.09
4400	10.61	16.46	7.68	26.16	1.06	0.92	40.20	22.74	2.11
4600	10.37	16.22	7.45	25.57	1.05	0.92	41.05	22.73	2.18
4800	10.12	15.99	7.25	24.67	1.04	0.93	41.23	22.69	2.24
5000	9.88	15.75	7.07	23.05	1.04	0.93	39.49	22.03	2.29
5200	9.64	15.53	6.96	21.34	1.03	0.94	41.89	22.53	2.33
5400	9.41	15.30	6.79	20.71	1.02	0.94	40.52	22.34	2.41
5600	9.17	15.08	6.65	19.07	1.02	0.94	40.76	21.92	2.45
5800	8.97	14.83	6.71	18.15	1.01	0.94	41.32	22.04	2.48
6000	8.77	14.61	6.68	17.41	1.00	0.94	41.05	21.69	2.51
6200	8.58	14.36	6.69	16.37	0.99	0.93	41.17	21.78	2.55
6400	8.38	14.13	6.74	15.43	0.98	0.93	41.19	21.77	2.47
6600	8.19	13.90	6.83	14.48	0.97	0.92	40.89	21.55	2.60
6800	8.00	13.65	6.93	13.89	0.97	0.91	40.81	21.62	2.64
7000	7.85	13.43	7.08	13.17	0.96	0.90	40.38	21.54	2.61

Typical Performance Data

Definitions:

Input Return Loss = -S11 (dB)

Gain(Power Gain) = S21 (dB)

Reverse Isolation = -S12 (dB)

Output Return Loss = -S22 (dB)

TEST CONDITIONS: Vd = 4.5V, Id =101.79 mA @ Temperature = -45degC

FREQ	Gain	Isolation	Input Return Loss	Output Return Loss	Stability		IP-3 Output	1dB Comp. Output	Noise Figure
					K	Measure			
(MHz)	(dB)	(dB)	(dB)	(dB)	K	Measure	(dBm)	(dBm)	(dB)
20	19.60	23.66	6.70	9.03	0.84	0.70	38.29	20.15	1.20
30	18.78	22.16	8.18	10.42	0.85	0.67	37.98	21.05	1.16
40	18.10	21.39	9.62	11.70	0.89	0.65	37.64	21.25	1.08
50	17.59	20.94	10.88	12.73	0.92	0.64	37.06	21.71	1.10
60	17.21	20.65	12.07	13.74	0.96	0.63	37.61	20.93	1.17
70	16.93	20.49	13.10	14.63	0.98	0.63	37.72	20.92	1.16
80	16.73	20.35	13.96	15.33	1.00	0.62	37.82	20.97	1.23
90	16.57	20.25	14.76	15.94	1.02	0.62	37.75	21.07	1.22
100	16.46	20.23	15.39	16.51	1.03	0.62	38.82	21.22	1.21
200	16.00	19.97	19.41	19.36	1.08	0.61	38.26	21.18	1.19
400	15.78	19.90	21.01	19.24	1.09	0.61	37.79	21.06	1.41
600	15.61	19.84	19.43	19.44	1.10	0.63	38.43	21.25	1.45
800	15.43	19.78	18.23	19.62	1.10	0.64	37.63	21.20	1.36
1000	15.23	19.68	16.80	20.09	1.10	0.66	39.67	21.34	1.43
1200	15.01	19.55	15.89	19.81	1.10	0.68	38.03	21.28	1.51
1400	14.75	19.42	14.83	19.61	1.10	0.69	39.10	21.33	1.44
1600	14.48	19.29	13.89	19.88	1.10	0.71	39.61	21.35	1.52
1800	14.20	19.13	13.12	20.02	1.10	0.73	38.37	21.25	1.55
2000	13.92	18.96	12.42	20.31	1.10	0.75	39.10	21.36	1.58
2200	13.62	18.78	11.79	20.59	1.10	0.77	40.35	21.63	1.60
2600	13.00	18.42	10.69	20.66	1.09	0.81	39.41	21.42	1.71
2800	12.70	18.23	10.22	21.23	1.09	0.83	38.99	21.45	1.76
3000	12.40	18.00	9.85	21.57	1.09	0.84	38.97	21.44	1.71
3200	12.12	17.80	9.48	22.35	1.09	0.86	39.06	21.50	1.85
3400	11.83	17.56	9.04	23.48	1.08	0.87	39.08	21.57	1.91
3600	11.54	17.35	8.66	23.68	1.08	0.89	39.11	21.59	1.97
3800	11.26	17.13	8.41	24.14	1.07	0.90	39.18	21.60	1.92
4000	10.99	16.91	8.11	24.66	1.07	0.91	39.03	21.71	1.98
4200	10.73	16.67	7.84	25.51	1.06	0.92	38.90	21.57	1.99
4400	10.48	16.44	7.61	25.37	1.06	0.93	38.25	21.41	2.05
4600	10.24	16.19	7.39	24.88	1.05	0.94	38.04	21.39	2.13
4800	9.99	15.99	7.19	24.13	1.05	0.94	38.45	21.40	2.17
5000	9.76	15.74	7.02	22.66	1.04	0.95	36.84	20.81	2.20
5200	9.52	15.52	6.91	20.99	1.03	0.95	38.10	21.20	2.23
5400	9.29	15.30	6.75	20.38	1.02	0.96	37.80	21.09	2.36
5600	9.05	15.08	6.61	18.83	1.02	0.96	37.00	20.67	2.34
5800	8.85	14.85	6.67	17.86	1.01	0.95	37.17	20.82	2.37
6000	8.65	14.62	6.64	17.12	1.00	0.95	36.91	20.53	2.44
6200	8.46	14.39	6.65	16.12	0.99	0.95	36.70	20.56	2.41
6400	8.26	14.15	6.70	15.18	0.99	0.94	36.94	20.54	2.38
6600	8.08	13.92	6.79	14.24	0.98	0.93	36.61	20.40	2.49
6800	7.89	13.69	6.88	13.65	0.97	0.92	36.30	20.34	2.50
7000	7.73	13.46	7.04	12.95	0.96	0.91	35.98	20.34	2.47

Typical Performance Data

Definitions:

Input Return Loss = -S11 (dB)

Gain(Power Gain) = S21 (dB)

Reverse Isolation = -S12 (dB)

Output Return Loss = -S22 (dB)

TEST CONDITIONS: Vd = 4.75V, Id = 116.73 mA @ Temperature = -45degC

FREQ	Gain	Isolation	Input Return Loss	Output Return Loss	Stability		IP-3 Output	1dB Comp. Output	Noise Figure
					K	Measure			
(MHz)	(dB)	(dB)	(dB)	(dB)	K	Measure	(dBm)	(dBm)	(dB)
20	19.71	23.72	6.77	9.16	0.84	0.69	40.66	20.77	1.29
30	18.88	22.31	8.30	10.55	0.85	0.67	40.12	21.71	1.22
40	18.20	21.45	9.71	11.80	0.89	0.65	39.12	21.97	1.13
50	17.69	21.10	11.00	12.79	0.93	0.64	38.33	22.35	1.17
60	17.31	20.74	12.17	13.80	0.96	0.63	38.52	21.60	1.19
70	17.03	20.52	13.23	14.65	0.98	0.62	38.40	21.61	1.15
80	16.83	20.44	14.05	15.32	1.00	0.62	38.02	21.71	1.26
90	16.68	20.37	14.87	15.90	1.02	0.62	37.49	21.76	1.25
100	16.56	20.31	15.53	16.45	1.03	0.62	38.35	21.91	1.24
200	16.11	20.06	19.49	19.05	1.08	0.61	37.28	21.86	1.23
400	15.88	19.95	20.94	18.87	1.09	0.61	36.85	21.73	1.42
600	15.72	19.92	19.39	19.10	1.10	0.62	37.07	21.93	1.48
800	15.54	19.87	18.23	19.35	1.10	0.64	36.57	21.89	1.36
1000	15.34	19.75	16.81	19.86	1.10	0.66	37.84	22.04	1.44
1200	15.11	19.64	15.92	19.67	1.10	0.67	37.15	22.01	1.52
1400	14.85	19.52	14.84	19.53	1.10	0.69	38.16	22.05	1.45
1600	14.59	19.37	13.92	19.86	1.10	0.71	38.43	22.09	1.52
1800	14.30	19.21	13.14	20.09	1.10	0.73	37.84	21.97	1.57
2000	14.01	19.04	12.46	20.43	1.10	0.75	39.00	22.13	1.59
2200	13.71	18.85	11.82	20.75	1.10	0.77	40.31	22.37	1.61
2600	13.09	18.47	10.71	20.88	1.09	0.81	39.60	22.15	1.73
2800	12.79	18.27	10.26	21.52	1.09	0.82	39.61	22.19	1.80
3000	12.49	18.04	9.89	21.90	1.09	0.84	39.76	22.17	1.76
3200	12.20	17.83	9.52	22.75	1.09	0.85	39.86	22.22	1.86
3400	11.91	17.60	9.09	23.94	1.08	0.87	40.01	22.29	1.92
3600	11.62	17.39	8.70	24.10	1.08	0.88	40.04	22.31	1.96
3800	11.34	17.15	8.45	24.67	1.07	0.89	40.45	22.31	1.98
4000	11.06	16.94	8.15	25.17	1.07	0.91	40.26	22.43	2.00
4200	10.81	16.69	7.88	26.00	1.06	0.91	40.21	22.29	2.07
4400	10.56	16.45	7.65	25.83	1.06	0.92	39.47	22.13	2.07
4600	10.31	16.22	7.43	25.24	1.05	0.93	39.77	22.13	2.14
4800	10.07	15.98	7.22	24.44	1.04	0.94	40.03	22.08	2.18
5000	9.83	15.74	7.05	22.89	1.04	0.94	38.10	21.44	2.23
5200	9.59	15.53	6.95	21.20	1.03	0.94	39.84	21.91	2.28
5400	9.35	15.30	6.78	20.58	1.02	0.95	39.07	21.76	2.39
5600	9.12	15.08	6.64	18.96	1.02	0.95	38.73	21.36	2.33
5800	8.92	14.83	6.70	18.04	1.01	0.95	39.01	21.43	2.40
6000	8.72	14.61	6.67	17.31	1.00	0.95	38.71	21.14	2.46
6200	8.52	14.37	6.67	16.27	0.99	0.94	38.69	21.18	2.51
6400	8.33	14.13	6.72	15.33	0.98	0.93	38.95	21.23	2.45
6600	8.14	13.90	6.82	14.36	0.97	0.92	38.20	21.02	2.54
6800	7.95	13.67	6.91	13.79	0.97	0.92	38.21	21.06	2.54
7000	7.80	13.45	7.07	13.08	0.96	0.90	37.74	21.04	2.54

Typical Performance Data

Definitions:

Input Return Loss = -S11 (dB)

Gain(Power Gain) = S21 (dB)

Reverse Isolation = -S12 (dB)

Output Return Loss = -S22 (dB)

TEST CONDITIONS: Vd = 5.25V, Id = 147.31mA @ Temperature = -45degC

FREQ	Gain	Isolation	Input Return Loss	Output Return Loss	Stability		IP-3 Output	1dB Comp. Output	Noise Figure
					K	Measure			
(MHz)	(dB)	(dB)	(dB)	(dB)	K	Measure	(dBm)	(dBm)	(dB)
20	19.85	23.71	6.90	9.33	0.84	0.69	41.79	22.01	1.56
30	19.01	22.35	8.43	10.72	0.85	0.67	41.46	22.81	1.39
40	18.33	21.57	9.88	11.92	0.89	0.65	41.57	23.19	1.27
50	17.82	21.20	11.17	12.97	0.93	0.64	39.90	23.58	1.26
60	17.45	20.90	12.34	13.87	0.96	0.63	38.75	22.78	1.29
70	17.17	20.68	13.38	14.71	0.98	0.62	38.52	22.80	1.24
80	16.97	20.56	14.23	15.34	1.00	0.61	38.17	22.89	1.31
90	16.82	20.51	15.03	15.90	1.02	0.61	37.25	22.95	1.30
100	16.71	20.41	15.66	16.43	1.03	0.61	37.88	23.08	1.27
200	16.26	20.20	19.58	18.75	1.08	0.60	36.63	23.04	1.25
400	16.04	20.12	20.89	18.53	1.09	0.61	36.18	22.88	1.44
600	15.88	20.07	19.34	18.80	1.10	0.62	36.42	23.07	1.50
800	15.69	20.00	18.24	19.06	1.10	0.64	36.02	23.02	1.39
1000	15.49	19.89	16.77	19.65	1.10	0.65	36.91	23.21	1.49
1200	15.26	19.78	15.92	19.54	1.10	0.67	36.68	23.16	1.54
1400	15.00	19.62	14.83	19.47	1.10	0.69	37.37	23.23	1.50
1600	14.73	19.48	13.93	19.86	1.10	0.71	37.58	23.27	1.55
1800	14.43	19.31	13.15	20.16	1.10	0.73	37.42	23.15	1.63
2000	14.15	19.14	12.48	20.59	1.10	0.75	38.46	23.35	1.64
2200	13.84	18.95	11.84	20.92	1.10	0.76	39.30	23.64	1.65
2600	13.22	18.55	10.75	21.21	1.09	0.80	39.19	23.38	1.80
2800	12.91	18.34	10.29	21.89	1.09	0.82	39.46	23.41	1.84
3000	12.61	18.12	9.93	22.35	1.09	0.83	39.96	23.39	1.82
3200	12.32	17.89	9.57	23.30	1.09	0.85	40.12	23.44	1.93
3400	12.03	17.66	9.13	24.50	1.08	0.86	40.20	23.50	2.00
3600	11.73	17.43	8.74	24.72	1.08	0.88	40.24	23.53	2.05
3800	11.45	17.19	8.49	25.31	1.07	0.89	40.85	23.54	2.07
4000	11.17	16.98	8.19	25.86	1.07	0.90	40.50	23.60	2.08
4200	10.92	16.73	7.91	26.78	1.06	0.91	40.59	23.48	2.20
4400	10.66	16.46	7.69	26.47	1.06	0.91	39.94	23.27	2.18
4600	10.41	16.23	7.46	25.83	1.05	0.92	41.22	23.30	2.25
4800	10.17	16.00	7.25	24.89	1.04	0.93	41.30	23.22	2.29
5000	9.93	15.75	7.08	23.22	1.04	0.93	39.93	22.45	2.33
5200	9.68	15.53	6.97	21.47	1.03	0.93	42.26	23.03	2.38
5400	9.45	15.32	6.80	20.84	1.02	0.94	40.96	22.81	2.46
5600	9.21	15.09	6.66	19.20	1.02	0.94	41.47	22.41	2.50
5800	9.01	14.83	6.71	18.27	1.01	0.94	42.05	22.57	2.52
6000	8.81	14.60	6.69	17.52	1.00	0.94	41.96	22.22	2.59
6200	8.62	14.37	6.69	16.47	0.99	0.93	42.65	22.31	2.66
6400	8.42	14.13	6.74	15.51	0.98	0.92	42.87	22.26	2.57
6600	8.23	13.89	6.83	14.56	0.97	0.92	42.89	22.07	2.63
6800	8.04	13.66	6.93	13.96	0.96	0.91	43.54	22.10	2.70
7000	7.89	13.42	7.09	13.23	0.96	0.89	42.56	22.03	2.73

Typical Performance Data

Definitions:

Input Return Loss = -S11 (dB)

Gain(Power Gain) = S21 (dB)

Reverse Isolation = -S12 (dB)

Output Return Loss = -S22 (dB)

TEST CONDITIONS: Vd = 5V, Id = 146.02 mA @ Temperature = +85degC

FREQ	Gain	Isolation	Input Return Loss	Output Return Loss	Stability		IP-3 Output	1dB Comp. Output	Noise Figure
					K	Measure			
(MHz)	(dB)	(dB)	(dB)	(dB)	K	Measure	(dBm)	(dBm)	(dB)
20	19.45	23.74	7.56	10.08	0.91	0.69	37.44	21.36	1.94
30	18.72	22.53	9.30	11.93	0.93	0.67	38.72	22.19	1.92
40	18.19	21.91	10.88	13.58	0.97	0.65	39.55	22.60	1.87
50	17.84	21.51	12.18	15.00	0.99	0.63	38.72	23.05	1.89
60	17.58	21.42	13.37	16.27	1.02	0.64	39.17	22.22	1.92
70	17.41	21.28	14.35	17.38	1.04	0.63	39.84	22.19	1.89
80	17.29	21.25	15.15	18.27	1.05	0.64	40.07	22.31	1.96
90	17.19	21.14	15.87	19.05	1.06	0.63	40.35	22.34	1.98
100	17.12	21.14	16.42	19.69	1.07	0.63	41.04	22.43	1.95
200	16.84	20.98	19.27	22.55	1.09	0.63	43.08	22.38	1.90
400	16.64	20.92	18.74	23.19	1.10	0.64	45.74	22.22	2.11
600	16.44	20.82	17.04	22.77	1.10	0.66	45.71	22.34	2.18
800	16.19	20.70	15.81	21.33	1.10	0.68	45.76	22.26	2.11
1000	15.91	20.56	14.54	20.52	1.09	0.70	43.54	22.40	2.20
1200	15.60	20.38	13.51	19.73	1.09	0.73	43.15	22.37	2.29
1400	15.27	20.18	12.66	19.14	1.08	0.75	42.28	22.45	2.30
1600	14.93	19.98	11.93	18.75	1.08	0.77	42.43	22.51	2.37
1800	14.57	19.77	11.33	18.41	1.07	0.79	41.68	22.39	2.41
2000	14.21	19.52	10.79	18.17	1.07	0.81	41.09	22.61	2.43
2200	13.84	19.30	10.27	18.10	1.06	0.83	41.19	22.86	2.52
2600	13.11	18.83	9.41	18.25	1.06	0.87	41.08	22.65	2.67
2800	12.76	18.58	9.02	18.53	1.06	0.89	40.84	22.67	2.70
3000	12.40	18.34	8.69	18.84	1.06	0.91	40.71	22.61	2.73
3200	12.06	18.10	8.36	19.30	1.05	0.92	40.32	22.66	2.90
3400	11.72	17.85	8.06	19.96	1.05	0.94	40.27	22.75	2.99
3600	11.40	17.60	7.79	20.48	1.05	0.95	40.47	22.74	3.05
3800	11.09	17.35	7.56	21.12	1.05	0.96	40.31	22.76	3.09
4000	10.78	17.11	7.35	21.71	1.05	0.97	40.42	22.77	3.10
4200	10.48	16.85	7.13	21.88	1.04	0.98	39.85	22.59	3.24
4400	10.19	16.62	6.97	21.99	1.04	0.99	39.80	22.39	3.24
4600	9.92	16.37	6.81	21.75	1.04	1.00	39.21	22.27	3.33
4800	9.64	16.13	6.69	20.92	1.03	1.00	39.62	22.29	3.44
5000	9.38	15.88	6.60	20.25	1.03	1.01	38.61	21.72	3.46
5200	9.12	15.64	6.52	19.48	1.02	1.01	39.08	22.07	3.55
5400	8.89	15.40	6.45	18.50	1.02	1.01	39.89	22.13	3.62
5600	8.64	15.15	6.40	17.61	1.01	1.01	38.30	21.56	3.64
5800	8.42	14.91	6.37	16.75	1.00	1.01	38.20	21.56	3.73
6000	8.19	14.69	6.35	15.79	1.00	1.00	38.35	21.32	3.80
6200	7.98	14.43	6.31	15.02	0.98	1.00	37.86	21.29	3.82
6400	7.76	14.20	6.31	14.14	0.98	0.99	37.80	21.31	3.82
6600	7.55	13.97	6.34	13.30	0.96	0.98	37.83	21.25	3.90
6800	7.34	13.74	6.38	12.59	0.95	0.98	37.10	21.12	4.01
7000	7.14	13.53	6.40	11.80	0.94	0.96	37.01	21.17	4.05

Typical Performance Data

Definitions:

Input Return Loss = -S11 (dB)

Gain(Power Gain) = S21 (dB)

Reverse Isolation = -S12 (dB)

Output Return Loss = -S22 (dB)

TEST CONDITIONS: Vd = 4.5V, Id = 119.26 mA @ Temperature = +85degC

FREQ	Gain	Isolation	Input Return Loss	Output Return Loss	Stability		IP-3 Output	1dB Comp. Output	Noise Figure
					K	Measure			
(MHz)	(dB)	(dB)	(dB)	(dB)	K	Measure	(dBm)	(dBm)	(dB)
20	19.37	23.74	7.30	10.05	0.91	0.71	36.92	20.22	1.70
30	18.63	22.52	9.01	11.84	0.93	0.68	37.95	21.10	1.73
40	18.10	21.94	10.57	13.46	0.97	0.67	38.13	21.45	1.69
50	17.74	21.43	11.85	14.88	0.99	0.64	37.44	21.82	1.72
60	17.48	21.36	13.01	16.12	1.02	0.65	38.28	21.07	1.76
70	17.30	21.23	14.01	17.22	1.04	0.64	38.71	21.06	1.75
80	17.17	21.17	14.78	18.07	1.05	0.64	38.76	21.17	1.80
90	17.08	21.04	15.45	18.83	1.06	0.63	39.81	21.20	1.80
100	17.01	21.03	16.01	19.47	1.07	0.64	39.77	21.31	1.80
200	16.72	20.88	18.79	22.17	1.09	0.63	41.92	21.26	1.80
400	16.51	20.81	18.36	22.46	1.10	0.65	43.13	21.11	1.96
600	16.30	20.71	16.68	21.92	1.10	0.67	41.37	21.25	2.05
800	16.05	20.56	15.53	20.42	1.09	0.68	40.52	21.18	1.95
1000	15.76	20.41	14.31	19.58	1.09	0.71	39.56	21.33	2.06
1200	15.45	20.21	13.31	18.80	1.08	0.73	39.00	21.30	2.13
1400	15.11	20.01	12.49	18.23	1.07	0.75	38.44	21.36	2.13
1600	14.77	19.80	11.78	17.83	1.07	0.77	38.76	21.42	2.21
1800	14.40	19.55	11.19	17.51	1.06	0.79	37.89	21.32	2.24
2000	14.04	19.32	10.67	17.30	1.06	0.81	37.79	21.51	2.29
2200	13.66	19.08	10.16	17.24	1.05	0.83	38.05	21.73	2.35
2600	12.93	18.60	9.34	17.40	1.05	0.87	37.46	21.56	2.51
2800	12.57	18.36	8.97	17.67	1.05	0.89	37.39	21.56	2.56
3000	12.22	18.10	8.65	17.97	1.05	0.91	37.25	21.55	2.55
3200	11.88	17.85	8.33	18.40	1.04	0.92	36.95	21.55	2.70
3400	11.54	17.61	8.04	18.98	1.04	0.94	36.93	21.65	2.77
3600	11.22	17.37	7.77	19.45	1.04	0.95	37.06	21.69	2.83
3800	10.91	17.11	7.56	19.93	1.04	0.96	36.96	21.68	2.85
4000	10.60	16.87	7.35	20.30	1.04	0.97	36.95	21.74	2.95
4200	10.30	16.62	7.15	20.34	1.04	0.98	36.51	21.53	3.03
4400	10.01	16.39	6.99	20.29	1.04	0.99	36.01	21.38	3.02
4600	9.74	16.15	6.83	19.96	1.03	0.99	35.91	21.26	3.14
4800	9.46	15.92	6.73	19.20	1.03	1.00	36.26	21.25	3.19
5000	9.20	15.67	6.64	18.62	1.03	1.00	35.09	20.72	3.21
5200	8.94	15.44	6.56	17.92	1.02	1.00	35.86	21.05	3.30
5400	8.71	15.20	6.50	17.13	1.02	1.00	36.32	21.09	3.39
5600	8.46	14.96	6.46	16.35	1.01	1.00	34.92	20.56	3.42
5800	8.24	14.74	6.43	15.61	1.01	0.99	35.11	20.57	3.44
6000	8.01	14.51	6.42	14.79	1.00	0.99	35.17	20.40	3.57
6200	7.80	14.26	6.38	14.10	0.99	0.98	34.69	20.34	3.55
6400	7.58	14.05	6.40	13.35	0.98	0.98	34.78	20.36	3.63
6600	7.37	13.83	6.43	12.60	0.97	0.97	34.74	20.35	3.67
6800	7.16	13.62	6.47	11.99	0.96	0.96	34.26	20.13	3.71
7000	6.95	13.40	6.50	11.28	0.95	0.95	34.11	20.25	3.80

Typical Performance Data

Definitions:

Input Return Loss = -S11 (dB)

Gain(Power Gain) = S21 (dB)

Reverse Isolation = -S12 (dB)

Output Return Loss = -S22 (dB)

TEST CONDITIONS: Vd = 4.75V, Id = 132.76 mA @ Temperature = +85degC

FREQ	Gain	Isolation	Input Return Loss	Output Return Loss	Stability		IP-3 Output	1dB Comp. Output	Noise Figure
					K	Measure			
(MHz)	(dB)	(dB)	(dB)	(dB)	K	Measure	(dBm)	(dBm)	(dB)
20	19.43	23.75	7.42	10.04	0.91	0.70	38.07	20.87	1.79
30	18.69	22.56	9.16	11.89	0.93	0.67	38.68	21.68	1.79
40	18.16	21.90	10.73	13.54	0.97	0.65	38.60	22.04	1.76
50	17.80	21.64	12.02	14.89	1.00	0.65	38.12	22.47	1.79
60	17.54	21.44	13.20	16.18	1.02	0.65	38.94	21.67	1.84
70	17.37	21.28	14.18	17.31	1.04	0.64	39.49	21.65	1.82
80	17.24	21.17	14.97	18.18	1.05	0.63	39.56	21.77	1.89
90	17.15	21.15	15.68	18.93	1.06	0.64	40.13	21.81	1.87
100	17.08	21.10	16.23	19.60	1.07	0.63	40.70	21.89	1.86
200	16.79	20.93	19.05	22.37	1.09	0.63	42.60	21.85	1.82
400	16.59	20.85	18.57	22.87	1.10	0.64	45.14	21.69	2.02
600	16.39	20.77	16.90	22.36	1.10	0.66	43.63	21.83	2.12
800	16.14	20.63	15.71	20.92	1.09	0.68	42.57	21.74	2.02
1000	15.85	20.50	14.44	20.10	1.09	0.70	41.67	21.90	2.11
1200	15.54	20.31	13.43	19.32	1.08	0.73	40.97	21.86	2.22
1400	15.21	20.12	12.60	18.75	1.08	0.75	40.38	21.94	2.19
1600	14.86	19.89	11.87	18.34	1.07	0.77	40.54	22.00	2.25
1800	14.50	19.69	11.28	18.03	1.07	0.79	39.80	21.87	2.31
2000	14.14	19.45	10.75	17.80	1.06	0.81	39.45	22.10	2.37
2200	13.77	19.22	10.23	17.75	1.06	0.83	39.85	22.33	2.40
2600	13.04	18.73	9.38	17.90	1.06	0.87	39.30	22.12	2.59
2800	12.68	18.49	9.00	18.19	1.05	0.89	39.07	22.14	2.61
3000	12.33	18.23	8.68	18.49	1.05	0.91	39.04	22.08	2.62
3200	11.99	18.00	8.35	18.94	1.05	0.92	38.74	22.15	2.74
3400	11.65	17.75	8.06	19.56	1.05	0.94	38.71	22.23	2.88
3600	11.33	17.49	7.79	20.06	1.05	0.95	38.83	22.24	2.92
3800	11.01	17.25	7.57	20.64	1.05	0.96	38.62	22.22	2.95
4000	10.71	17.00	7.36	21.13	1.05	0.97	38.62	22.26	3.05
4200	10.41	16.75	7.14	21.23	1.04	0.98	38.39	22.10	3.09
4400	10.12	16.52	6.99	21.24	1.04	0.99	37.90	21.90	3.17
4600	9.84	16.28	6.83	20.91	1.04	1.00	37.57	21.78	3.21
4800	9.57	16.04	6.71	20.15	1.03	1.00	37.89	21.80	3.27
5000	9.31	15.78	6.62	19.52	1.03	1.00	36.70	21.25	3.33
5200	9.05	15.55	6.54	18.78	1.02	1.00	37.47	21.57	3.42
5400	8.81	15.30	6.48	17.87	1.02	1.00	38.18	21.66	3.48
5600	8.57	15.07	6.43	17.05	1.01	1.00	36.56	21.07	3.51
5800	8.35	14.82	6.40	16.24	1.00	1.00	36.67	21.12	3.56
6000	8.12	14.61	6.38	15.34	1.00	1.00	36.73	20.85	3.66
6200	7.91	14.37	6.35	14.60	0.99	0.99	36.28	20.87	3.66
6400	7.69	14.13	6.36	13.79	0.98	0.99	36.24	20.85	3.71
6600	7.48	13.91	6.39	13.00	0.97	0.98	36.24	20.80	3.78
6800	7.27	13.68	6.42	12.33	0.96	0.97	35.74	20.65	3.82
7000	7.07	13.48	6.45	11.58	0.95	0.96	35.54	20.73	3.87

Typical Performance Data

Definitions:

Input Return Loss = -S11 (dB)

Gain(Power Gain) = S21 (dB)

Reverse Isolation = -S12 (dB)

Output Return Loss = -S22 (dB)

TEST CONDITIONS: Vd = 5.25V, Id = 158.85 mA @ Temperature = +85degC

FREQ	Gain	Isolation	Input Return Loss	Output Return Loss	Stability		IP-3 Output	1dB Comp. Output	Noise Figure
					K	Measure			
(MHz)	(dB)	(dB)	(dB)	(dB)	K	Measure	(dBm)	(dBm)	(dB)
20	19.45	23.82	7.70	10.13	0.92	0.70	37.69	21.81	2.08
30	18.72	22.58	9.46	11.99	0.94	0.67	38.63	22.66	2.04
40	18.20	21.97	11.03	13.64	0.97	0.65	39.16	23.11	1.98
50	17.84	21.58	12.32	15.09	1.00	0.64	38.59	23.53	2.01
60	17.60	21.46	13.54	16.33	1.03	0.64	39.26	22.69	2.04
70	17.42	21.34	14.54	17.45	1.04	0.64	39.63	22.68	2.03
80	17.30	21.29	15.35	18.36	1.06	0.64	39.64	22.80	2.08
90	17.21	21.18	16.06	19.15	1.06	0.63	40.43	22.81	2.07
100	17.15	21.14	16.60	19.80	1.07	0.63	40.85	22.91	2.08
200	16.87	20.99	19.46	22.73	1.09	0.63	42.91	22.86	2.02
400	16.67	20.94	18.89	23.48	1.10	0.64	45.29	22.69	2.21
600	16.47	20.86	17.16	23.08	1.10	0.66	45.78	22.80	2.27
800	16.22	20.74	15.89	21.66	1.10	0.68	45.16	22.71	2.21
1000	15.94	20.60	14.61	20.83	1.09	0.70	44.55	22.86	2.31
1200	15.64	20.45	13.57	20.03	1.09	0.73	44.48	22.83	2.39
1400	15.31	20.24	12.71	19.45	1.08	0.75	43.40	22.90	2.38
1600	14.97	20.04	11.97	19.04	1.08	0.77	42.97	22.97	2.46
1800	14.61	19.83	11.36	18.69	1.08	0.79	43.05	22.85	2.50
2000	14.25	19.60	10.81	18.44	1.07	0.81	41.86	23.07	2.55
2200	13.88	19.38	10.29	18.37	1.07	0.83	41.91	23.34	2.61
2600	13.16	18.89	9.41	18.49	1.06	0.87	41.70	23.12	2.78
2800	12.80	18.67	9.03	18.79	1.06	0.89	41.69	23.13	2.83
3000	12.44	18.43	8.69	19.06	1.06	0.91	41.96	23.07	2.84
3200	12.10	18.18	8.36	19.54	1.06	0.93	41.30	23.14	3.01
3400	11.76	17.93	8.05	20.17	1.06	0.94	40.96	23.20	3.10
3600	11.44	17.70	7.78	20.76	1.06	0.96	41.13	23.23	3.18
3800	11.13	17.43	7.55	21.39	1.05	0.97	41.28	23.20	3.20
4000	10.81	17.19	7.34	22.09	1.05	0.98	41.38	23.23	3.27
4200	10.52	16.93	7.11	22.35	1.05	0.99	40.77	23.04	3.36
4400	10.23	16.69	6.96	22.46	1.04	1.00	40.89	22.85	3.43
4600	9.96	16.44	6.79	22.31	1.04	1.00	40.63	22.72	3.46
4800	9.68	16.20	6.67	21.54	1.04	1.01	40.79	22.71	3.54
5000	9.42	15.94	6.57	20.82	1.03	1.01	40.35	22.17	3.64
5200	9.16	15.71	6.49	20.03	1.03	1.01	40.38	22.50	3.66
5400	8.93	15.46	6.42	18.99	1.02	1.02	41.08	22.56	3.75
5600	8.68	15.22	6.37	18.07	1.01	1.02	39.81	21.94	3.81
5800	8.46	14.97	6.34	17.14	1.00	1.01	39.79	21.99	3.88
6000	8.23	14.73	6.31	16.16	0.99	1.01	39.81	21.74	3.93
6200	8.02	14.49	6.27	15.31	0.98	1.01	39.21	21.70	3.97
6400	7.80	14.24	6.28	14.43	0.97	1.00	39.14	21.67	3.99
6600	7.60	14.02	6.30	13.53	0.96	0.99	39.10	21.56	4.08
6800	7.38	13.78	6.33	12.80	0.95	0.98	38.47	21.45	4.18
7000	7.18	13.57	6.35	11.97	0.94	0.97	38.46	21.51	4.15

Typical Performance Curves

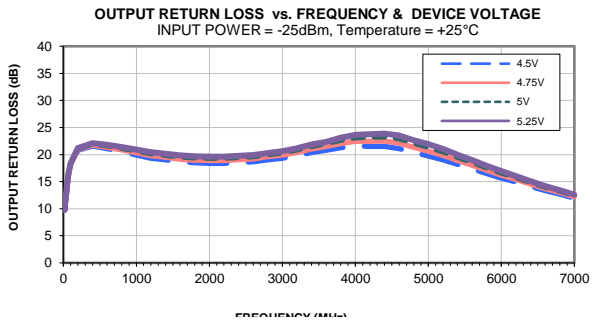
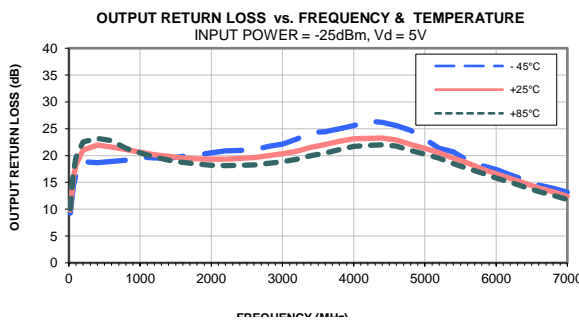
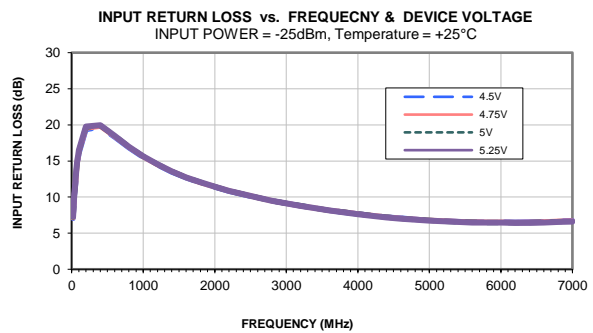
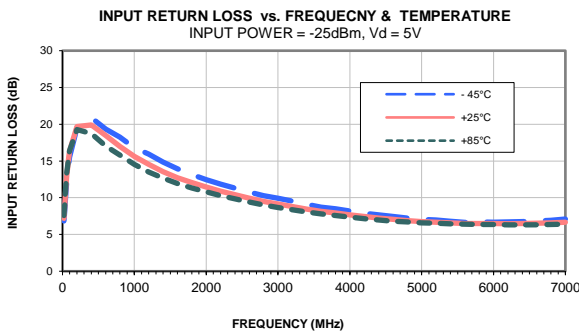
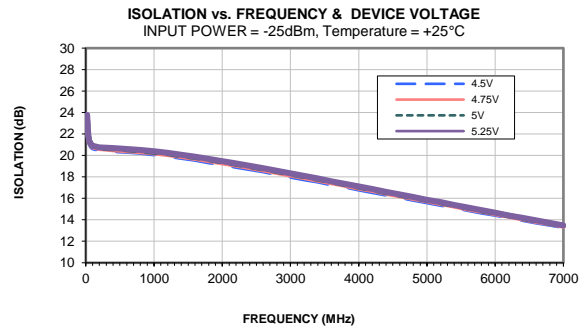
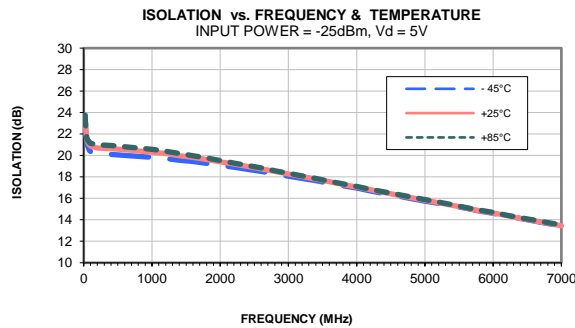
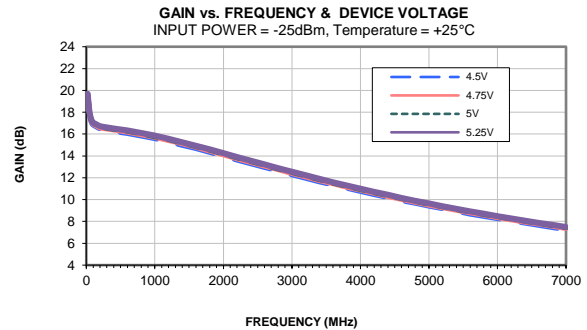
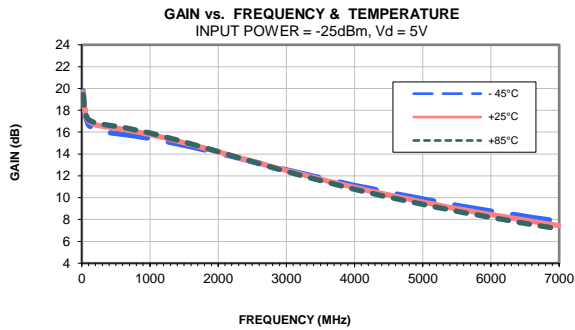

P.O. Box 350166, Brooklyn, New York 11235-0003 (718) 934-4500 • Fax (718) 332-4661 For detailed performance specs & shopping online see Mini-Circuits web site
The Design Engineers Search Engine Provides ACTUAL Data Instantly From MINI-CIRCUITS At: www.minicircuits.com



IF/RF MICROWAVE COMPONENTS

Typical Performance Curves

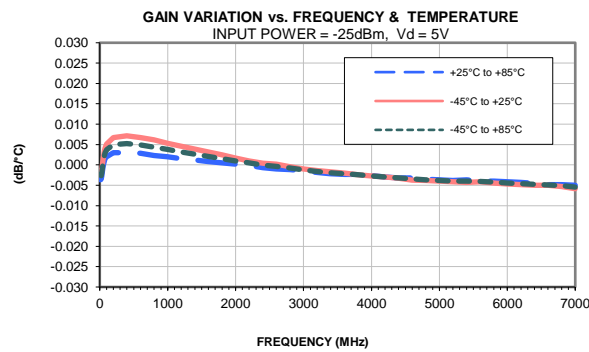
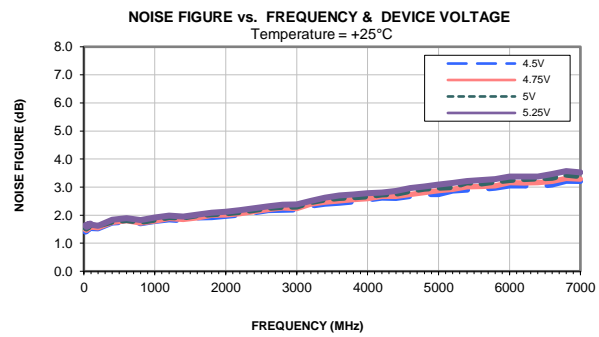
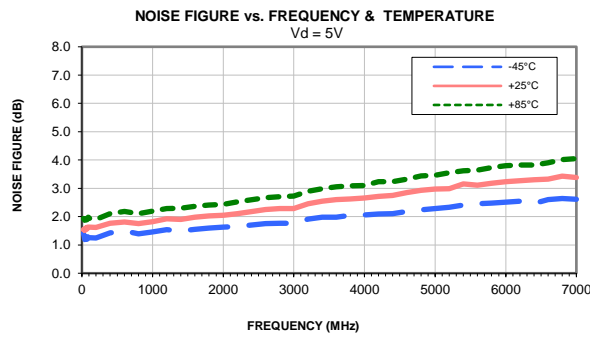
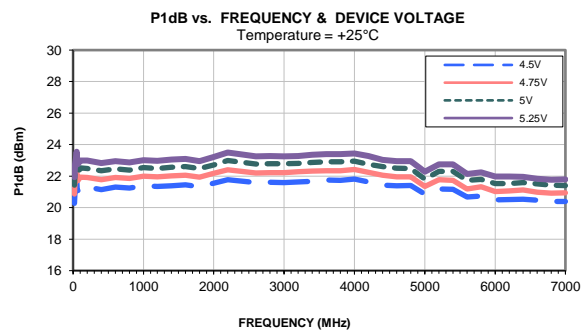
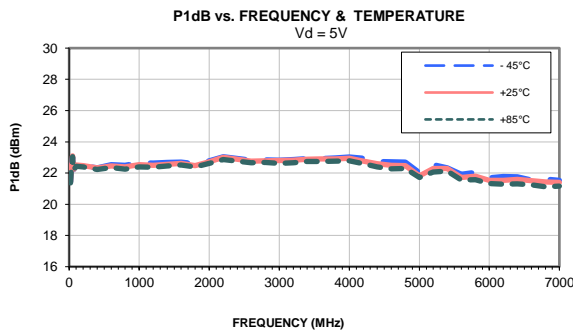
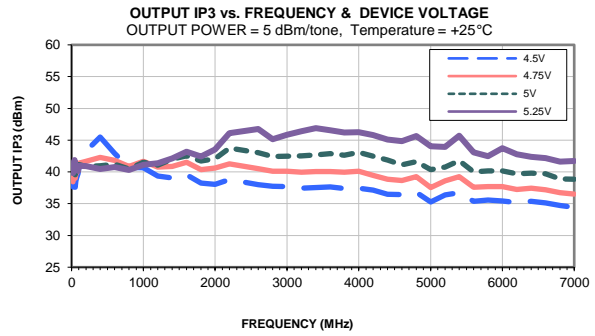
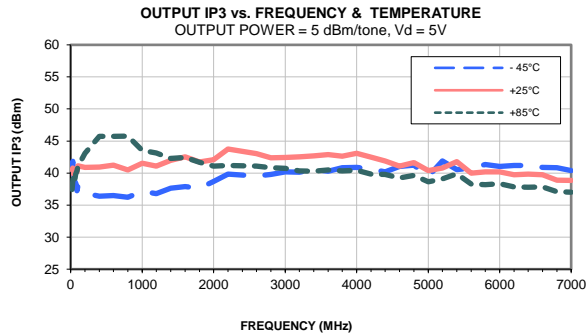

Outline Dimensions

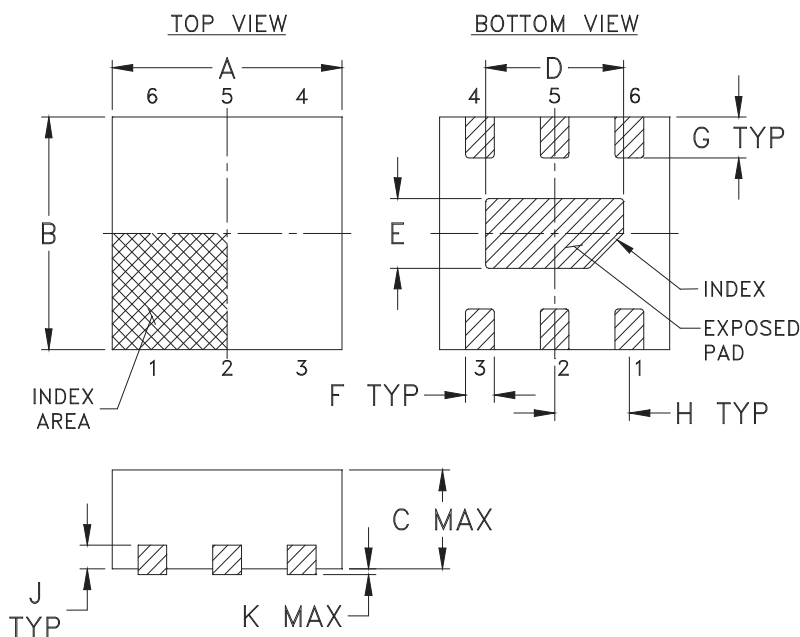

PCB Land Pattern

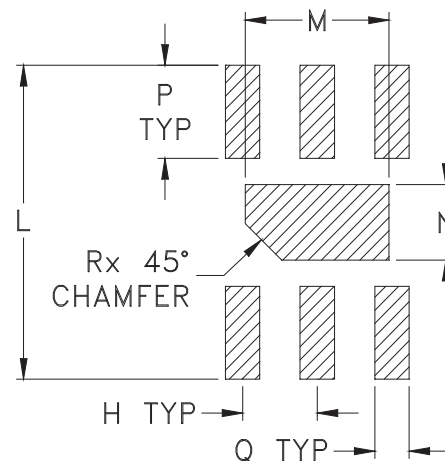

Suggested Layout,
Tolerance to be within $\pm .002$

CASE #.	A	B	C	D	E	F	G	H	J	K	L	M	N	P
MC1630-1	.079 (2.00)	.079 (2.00)	.039 (1.00)	.047 (1.20)	.024 (.60)	.010 (.25)	.014 (.35)	.026 (.65)	.008 (.20)	.002 (.05)	.106 (2.70)	.049 (1.25)	.026 (.65)	.031 (.80)

CASE #.	Q	R	WT, GRAM
MC1630-1	.012 (.30)	.012 (.30)	.006

Dimensions are in inches (mm). Tolerances: 2 Pl. $\pm .01$; 3 Pl. $\pm .005$

Notes:

- Case material: Plastic.
- Termination finish:
For RoHS Case Styles: Tin-Silver over Nickel plated or Matte-Tin plated (See Data sheet).
All models, (+) suffix.
- Lead #1 identifier shall be located in the cross-hatched area shown.
Identifier may be either a molded or marked feature.

Tape & Reel Packaging TR-F66

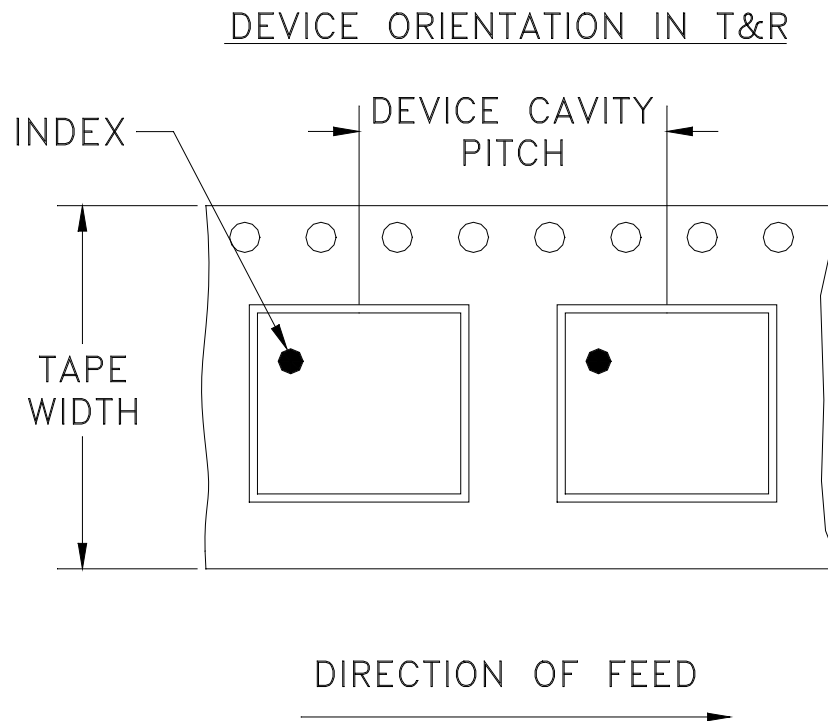

Tape Width, mm	Device Cavity Pitch, mm	Reel Size, inches	Devices per Reel see note	
8	4	7	Small quantity standard	20
				50
				100
				200
				500
		7	Standard	1000, 2000, 3000

Note: Please consult individual model data sheet to determine device per reel availability.

Mini-Circuits carrier tape materials provide protection from ESD (Electro-Static Discharge) during handling and transportation. Tapes are static dissipative and comply with industry standards EIA-481/EIA-541.

Go to: www.minicircuits.com/pages/pdfs/tape.pdf

Mini-Circuits®

INTERNET <http://www.minicircuits.com>

P.O. Box 350166, Brooklyn, New York 11235-0003 (718) 934-4500 Fax (718) 332-4661

Distribution Centers NORTH AMERICA 800-654-7949 • 417-335-5935 • Fax 417-335-5945 • EUROPE 44-1252-832600 • Fax 44-1252-837010

Mini-Circuits ISO 9001 & ISO 14001 Certified

THIRD ANGLE PROJECTION

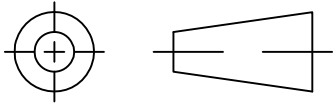

REVISIONS

REV	ECN No.	DESCRIPTION	DATE	DR	AUTH
OR	M159615	NEW RELEASE	01/05/17	GF	RS
A	M169363	CHANGED PIN CODE	08/02/18	GF	IL

SUGGESTED MOUNTING CONFIGURATION FOR
MC1630-1 CASE STYLE, "06AM06" PIN CODE

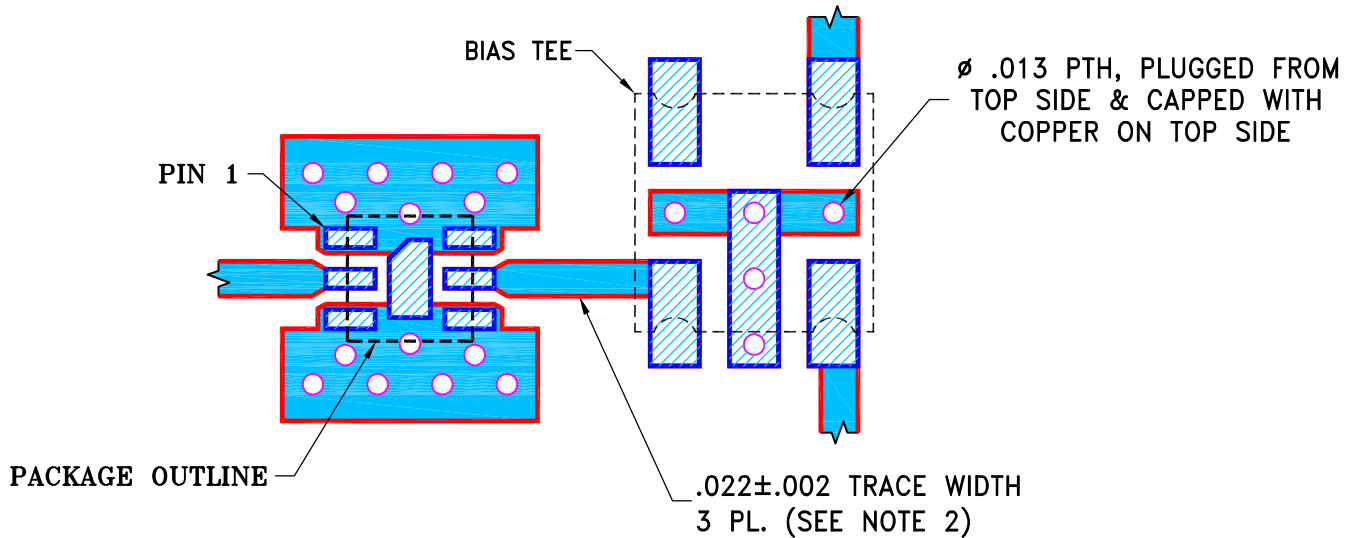

COPPER LAYER 1

COMPONENT	SIZE
DUT	2X2mm 6 LEAD MCLP
BIAS TEE	.15"X.15"

NOTES:

1. PCB IS MULTILAYER PCB, SEE STACK-UP DIAGRAM.
2. TRACE WIDTH & GAP PARAMETERS ARE SHOWN FOR ROGERS RO 4350B WITH DIELECTRIC THICKNESS $.010 \pm .001$ "; COPPER: 1/2 OZ. FOR OTHER MATERIALS TRACE WIDTH AND GAP MAY NEED TO BE MODIFIED.
3. COPPER LAYER 3 OF THE PCB IS CONTINUOUS GROUND PLANE.

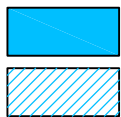

SOLID BLUE DENOTES PCB COPPER LAYOUT WITH SMOBC (SOLDER MASK OVER BARE COPPER)
 HATCHED BLUE DENOTES COPPER LAND PATTERN FREE OF SOLDER MASK

UNLESS OTHERWISE SPECIFIED	INITIALS		DATE
	DRAWN	GF	12/29/16
	CHECKED	IL	01/05/17
	APPROVED	RS	01/05/17

Mini-Circuits® 13 Neptune Avenue
Brooklyn NY 11235

PL, 06AM06, MC1630-1, TB-901+

SIZE	CODE IDENT	DRAWING NO:	REV:
A	15542	98-PL-493	A
FILE:	98PL493	SCALE: 8:1	SHEET: 1 OF 2

Mini-Circuits®
 THIS DOCUMENT AND ITS CONTENTS ARE THE PROPERTY OF MINI-CIRCUITS. EXCEPT FOR USE EXPRESSLY GRANTED, IN WRITING, TO ITS VENDORS, VENDEE AND THE UNITED STATES GOVERNMENT, MINI-CIRCUITS RESERVES ALL PROPRIETARY DESIGN, USE, MANUFACTURING AND REPRODUCTION RIGHTS THERETO. THESE CONTENTS SHALL NOT BE USED, DUPLICATED OR DISCLOSED TO ANY OUTSIDE PARTY, IN WHOLE OR IN PART, WITHOUT WRITTEN PERMISSION OF MINI-CIRCUITS.

SCRATCH IN COPPER
LAYER 2 UNDER
BIAS TEE PADS, 4 PL.

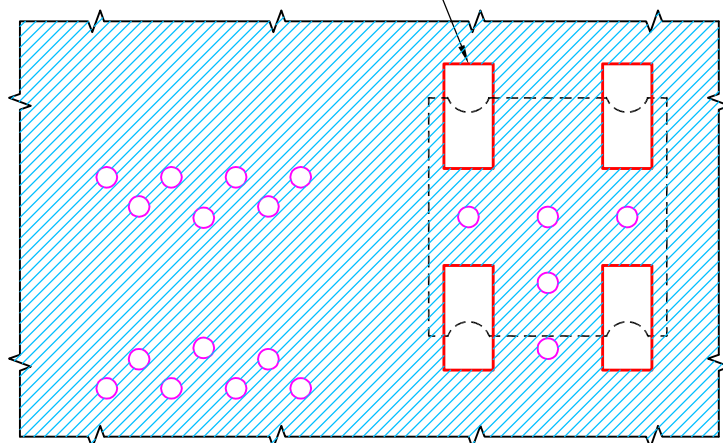

COPPER LAYER 2

STACK-UP DIAGRAM

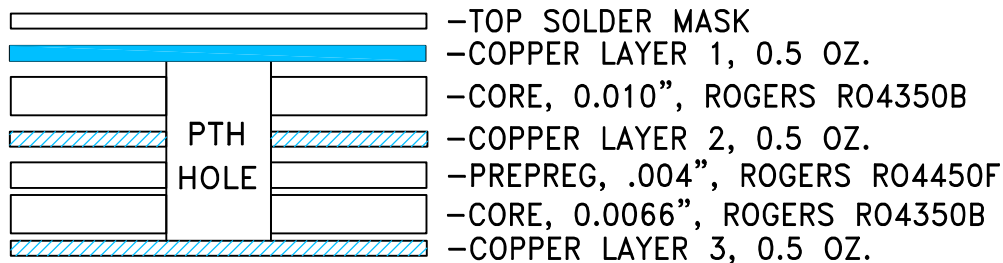

1. TOTAL FINISHED THICKNESS 0.026" ± 10%.
2. PTH HOLES PRESENT FROM COPPER LAYER 1 TO 3.

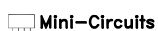

THIS DOCUMENT AND ITS CONTENTS ARE THE PROPERTY OF MINI-CIRCUITS. EXCEPT FOR USE EXPRESSLY GRANTED, IN WRITING, TO ITS VENDORS, VENDEE AND THE UNITED STATES GOVERNMENT, MINI-CIRCUITS RESERVES ALL PROPRIETARY DESIGN, USE, MANUFACTURING AND REPRODUCTION RIGHTS THERETO. THESE CONTENTS SHALL NOT BE USED, DUPLICATED OR DISCLOSED TO ANY OUTSIDE PARTY, IN WHOLE OR IN PART, WITHOUT WRITTEN PERMISSION OF MINI-CIRCUITS.

ALL DIMENSIONS ARE IN INCHES EXCEPT OTHERWISE SPECIFIED

SIZE A	CODE IDENT 15542	DRAWING NO: 98-PL-493	REV: A
FILE: 98PL493	SCALE: 8:1	SHEET: 2	OF 2

Evaluation Board and Circuit

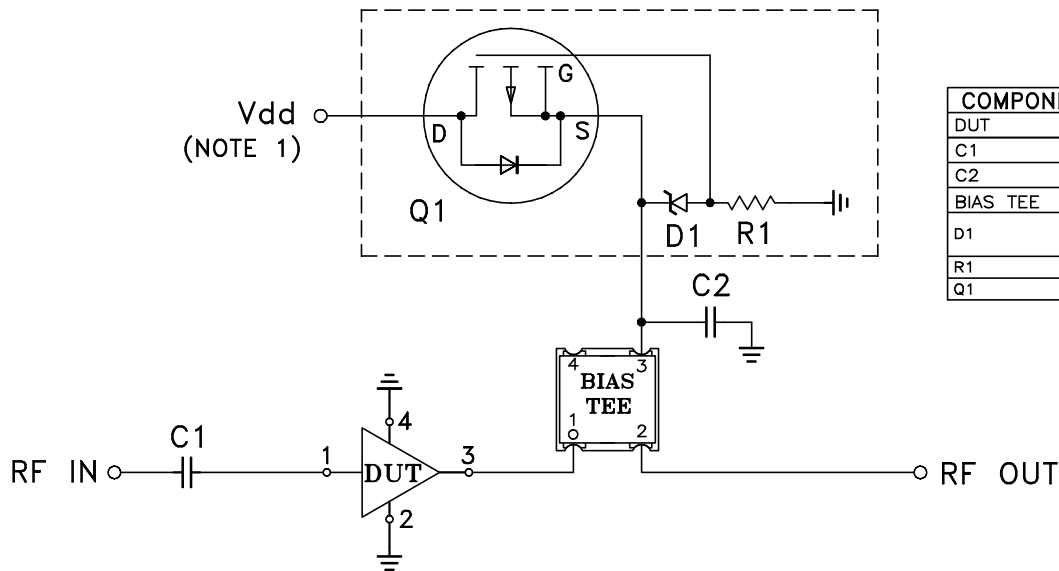
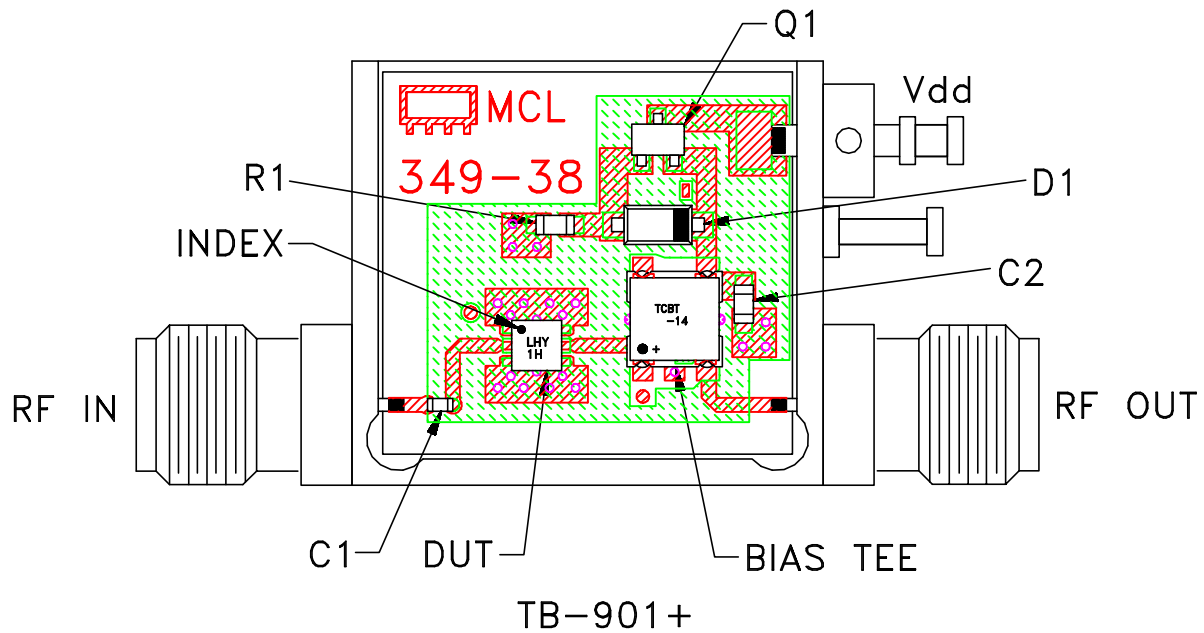

COMPONENT	VALUE	SIZE
DUT	LHY-1H+	3X3 MM
C1	1 nF	0402
C2	1 nF	0603
BIAS TEE	Mini-Circuits TCBT-14+	-
D1	Zener Diode 5.6V ONSEMI MMSZ4690T1G	SOD123
R1	1.5 kOhm	
Q1	Transistor ONSEMI FET NTS4101P	SOT323

Schematic Diagram

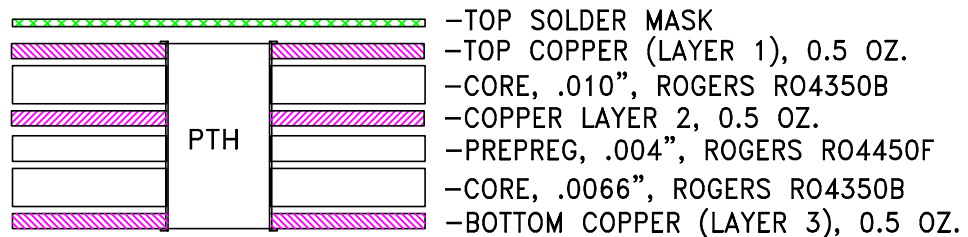

Stack-Up Diagram

NOTES:

1. Vs voltage: $+5 \pm 0.2V$.
2. SMA Female connectors.
3. PCB material: Rogers R04350 or equivalent, dielectric constant=3.5, Total Finished Thickness - $.026'' \pm 10\%$.

Mini-Circuits®

All Mini-Circuits products are manufactured under exacting quality assurance and control standards, and are capable of meeting published specifications after being subjected to any or all of the following physical and environmental test.

Specification	Test/Inspection Condition	Reference/Spec
Operating Temperature	-40° to 85° C or -45° to 85° C or -55° to 105° C or -40° to 105° C or -40° to 95° C Ambient Environment	Individual Model Data Sheet
Storage Temperature	-55° to 100° C or -65° to 150° Ambient Environment	Individual Model Data Sheet
HTOL	1000 hours at 125°C	MIL-STD-883, Method 1005, Condition B
Thermal Shock	-55° to 100°C, 100 cycles	MIL-STD-202, Method 107, Condition A-3, except +100°C
Mechanical Shock	1.5Kg, 0.5 ms, 5 shock pulses, Y1 direction only	MIL-STD-883, Method 2002, Condition B, except Y1 direction only
Vibration (Variable Frequency)	50g peak	MIL-STD-883, Method 2007, Condition B
Autoclave	15 psig, 100% RH, 121°C, 96 hours	JESD22-A102, Condition C
HAST	130°C, 85% RH, 96 hours	JESD22-A110
Solderability	10X Magnification	J-STD-002, Para 4.2.5, Test S, 95% Coverage
Solder Reflow Heat	Sn-Pb Eutetic Process: 240°C peak Pb-Free Process: 260°C peak	J-STD-020, Table 4-1, 4-2 and 5-2; Figure 5-1
Moisture Sensitivity: Level 1	Bake at 125°C for 24 hours Soak at 85°C/85% RH for 168 hours, Reflow 3 cycles at 260°C peak	J-STD-020

All Mini-Circuits products are manufactured under exacting quality assurance and control standards, and are capable of meeting published specifications after being subjected to any or all of the following physical and environmental test.

Specification	Test/Inspection Condition	Reference/Spec
Marking Resistance to Solvents	Isopropyl alcohol + mineral spirits at 25°C; terpene defluxer at 25°C; distilled water + proylene glycol monomethyl ether + monoethanolamine at 63°C to 70°C	MIL-STD-202, Method 215