



ULTRA HIGH DYNAMIC RANGE

Monolithic Amplifier

LHA-13LN+

50Ω 1 MHz to 1 GHz

THE BIG DEAL

- Ultra-High IP3, +38.3 dBm typ.
- Gain, 22.4 dB typ. at 0.5 GHz
- Low supply voltage, +3 to +5V
- Excellent Noise Figure, 1.1 dB typ.

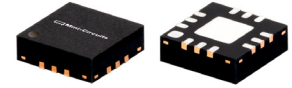

Generic photo used for illustration purposes only

CASE STYLE: DQ1225

+RoHS Compliant

The +Suffix identifies RoHS Compliance. See our website for methodologies and qualifications

APPLICATIONS

- Base station infrastructure
- CATV
- Cellular

PRODUCT OVERVIEW

LHA-13LN+ (RoHS compliant) is an advanced wideband amplifier fabricated using E-PHEMT technology and offers extremely high dynamic range over a broad frequency range and with low noise figure. In addition, the LHA-13LN+ has good input and output return loss over a broad frequency range. LHA-13LN+ is enclosed in a 3mm x 3mm, 12-lead MCLP package and has very good thermal performance.

KEY FEATURES

Feature	Advantages
Broad Band: 1 MHz to 1 GHz	Broadband covering primary wireless communications bands: VHF, UHF, Cellular
Extremely High IP3 +36.1 dBm typical at 1 MHz +38.3 dBm typical at 0.5 GHz	The LHA-13LN+ matches industry leading IP3 performance relative to device size and power consumption. The combination of the design and E-PHEMT Structure provides enhanced linearity over a broad frequency range as evidence in the IP3 being approximately 13-17 dB above the P1dB point. This feature makes this amplifier ideal for use in: <ul style="list-style-type: none"> • Driver amplifiers for complex waveform up converter paths • Drivers in linearized transmit systems • Secondary amplifiers in ultra-High Dynamic range receivers
Low Noise Figure, 0.9 dB at 0.5 GHz	Enables lower system noise figure performance and along with High OIP3 provides high dynamic range
Low Supply Voltage	LHA-13LN+ supports low supply voltage operations which indicate low power consumption

REV. A
ECO-011665
LHA-13LN+
MCL NY
240725





ULTRA HIGH DYNAMIC RANGE

Monolithic Amplifier

LHA-13LN+

Mini-Circuits

50Ω 1 MHz to 1 GHz

ELECTRICAL SPECIFICATIONS¹ AT +25°C, 50Ω, UNLESS NOTED OTHERWISE

Parameter	Condition (MHz)	Vd=+5V ¹			Vd=+3V ¹	Units
		Min.	Typ.	Max.	Typ.	
Frequency Range		1		1000	1-1000	MHz
Gain	1	22.1	24.6	27.1	23.7	dB
	20	—	24.0	—	23.2	
	250	—	22.8	—	22.0	
	500	20.2	22.4	24.6	21.5	
	1000	—	20.1	—	18.7	
Input Return Loss	1		11		10	dB
	20		15		15	
	250		18		18	
	500		18		15	
	1000		11		9	
Output Return Loss	1		12		12	dB
	20		20		22	
	250		18		20	
	500		25		22	
	1000		11		9	
Reverse Isolation	500		26		25.6	dB
Output Power @ 1 dB compression	1		+20.8		+14.6	dBm
	20		+22.0		+15.8	
	250		+24.2		+19.3	
	500		+23.9		+18.9	
	1000		+23.3		+17.6	
Output IP3 ²	1	—	+36.1		+29.6	dBm
	20	—	+38.9		+32.5	
	250	—	+40.0		+33.6	
	500	+36	+38.3		+32.3	
	1000	—	+36.4		+28.5	
Noise Figure	1		3.1		3.0	dB
	20		1.1		1.0	
	250		0.9		1.0	
	500		1.1		1.0	
	1000		1.2		1.2	
Device Operating Voltage			+5.0		+3.0	V
Device Operating Current			143	162	73	mA
Device Current Variation vs. Temperature ³			98.2		-29.7	μA/°C
Device Current Variation vs Voltage			0.0355		0.0354	mA/mV
Thermal Resistance, junction-to-ground lead Junction-to-ground lead at 85°C stage temperature			23.3		23.3	°C/W

1. Measured on Mini-Circuits Characterization test board TB-1063-13LN+. See Characterization Test Circuit (Fig. 1)

2. Tested at Pout= 0 dBm / tone.

3. (Current at 105°C – Current at -45°C)/140

ABSOLUTE MAXIMUM RATINGS⁴

Parameter	Ratings
Operating Temperature (ground lead)	-40°C to +95°C
Storage Temperature	-65°C to +150°C
Power Dissipation	3.3 W ⁵
Input Power (CW)	+21 dBm (5 minutes max) ⁶ +10 dBm (continuous) for 1-10 MHz +11 dBm (continuous) for 10-1000 MHz
DC Voltage on Pad ⁷	+10 V

4. Permanent damage may occur if any of these limits are exceeded.

Electrical maximum ratings are not intended for continuous normal operation.

5. up to 85°C, derate linearly to 2.5 W at 95°C.

6. up to 85°C, derate linearly to 18 dBm at 95°C.





ULTRA HIGH DYNAMIC RANGE

Monolithic Amplifier

LHA-13LN+

50Ω 1 MHz to 1 GHz

SIMPLIFIED SCHEMATIC AND PAD DESCRIPTION

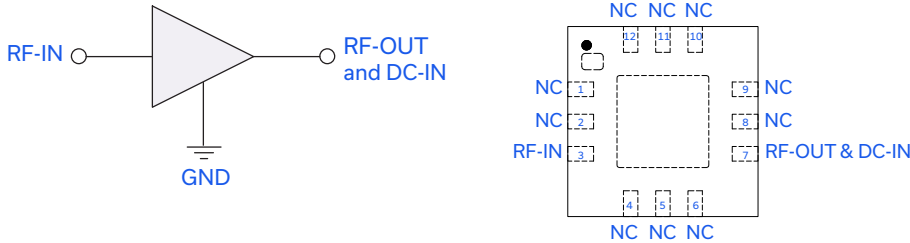

Function	Pad Number	Description
RF-IN	3	RF Input
RF-OUT and DC-IN	7	RF Output and DC Bias
GND	Paddle	Connections to ground.
NC	1-2, 4-6, 8-12	No connection, grounded externally

CHARACTERIZATION TEST / RECOMMENDED APPLICATION CIRCUIT

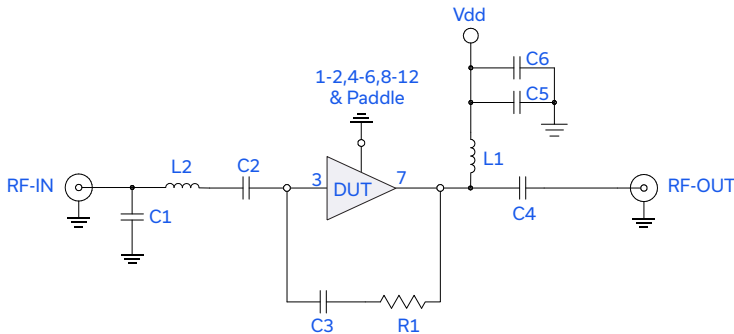

Fig 1. Block Diagram of Test Circuit used for characterization. (DUT soldered on Mini-Circuits Characterization test board TB-1063-13HLN+) Gain, Return loss, Output power at 1dB compression (P1 dB), output IP3 (OIP3) and noise figure measured using Agilent's N5242A PNA-X microwave network analyzer.

Conditions:

1. Gain and Return loss: $P_{IN} = -25\text{dBm}$
2. Output IP3 (OIP3): Two tones, spaced 1 MHz apart, 0 dBm/ tone at output.

Components	Size	Value	Manufacturer	P/N
C1	0402	1.5 pF	Murata	GRM1555C1H1R5CA01
C2	0603	2.2 uF		GRM188R61C225KE15
C3	0402	0.1 uF		GRM155R71C104KA88
C4	0603	2.2uF		GRM188R61C225KE15
C5	0402	1000 pF		GRM1555C1H102JA01
C6	0805	10 uF		GRM21BR61C106KE15
L1	1210	15 uH	Coilcraft	LQH32DN150K53L
L2	0603	5.1 nH		0603CS-5N1XJL
R1	0402	1500 Ohms	Koa	RK73H1ELTP1501F

PRODUCT MARKING

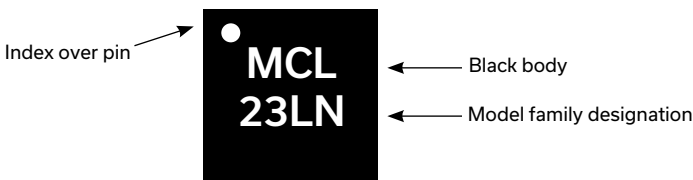

Marking may contain other features or characters for internal lot control





ULTRA HIGH DYNAMIC RANGE

Monolithic Amplifier

LHA-13LN+

Mini-Circuits

50Ω 1 MHz to 1 GHz

ADDITIONAL DETAILED TECHNICAL INFORMATION IS AVAILABLE ON OUR DASHBOARD. [CLICK HERE](#)

Performance Data	Data Table Swept Graphs
Case Style	DQ1225 Plastic package, exposed paddle lead finish: Matte-Tin
Tape & Reel Standard quantities available on reel	F66 7" reels with 20, 50, 100, 200, 500, 1K, 2K or 3K devices
Suggested Layout for PCB Design	PL-594
Evaluation Board	TB-1063-13LN+
Environmental Ratings	ENV08T9

ESD RATING

Human Body Model (HBM): Class 1B (Pass 500 V) in accordance with ANSI/ESD STM 5.1 - 2001

MSL RATING

Moisture Sensitivity: MSL1 in accordance with IPC/JEDEC J-STD-020D

NOTES

- A. Performance and quality attributes and conditions not expressly stated in this specification document are intended to be excluded and do not form a part of this specification document.
- B. Electrical specifications and performance data contained in this specification document are based on Mini-Circuit's applicable established test performance criteria and measurement instructions.
- C. The parts covered by this specification document are subject to Mini-Circuits standard limited warranty and terms and conditions (collectively, "Standard Terms"); Purchasers of this part are entitled to the rights and benefits contained therein. For a full statement of the standard terms and the exclusive rights and remedies thereunder, please visit Mini-Circuits' website at www.minicircuits.com/terms/viewterm.html



Typical Performance Data

NOTE: Use PDF Bookmarks to view DATA at required conditions

Definitions:

Input Return Loss = -S11 (dB)

Gain(Power Gain) = S21 (dB)

Reverse Isolation = -S12 (dB)

Output Return Loss = -S22 (dB)

TEST CONDITIONS: Vd = 3.00V, Id = 72.96765mA @ Temperature = +25°C

FREQ	Gain	Isolation	Input Return Loss	Output Return Loss	Stability		IP-3 Output	1dB Comp. Output	Noise Figure
					K	Measure			
(MHz)	(dB)	(dB)	(dB)	(dB)	K	Measure	(dBm)	(dBm)	(dB)
1.00	23.80	28.90	9.90	11.30	1.10	0.63	30.98	14.62	2.92
3.00	24.10	28.40	12.30	22.30	1.09	0.66	30.96	14.89	1.94
5.00	24.10	28.20	12.70	31.30	1.08	0.66	31.19	14.90	1.69
7.00	24.00	27.90	13.00	34.70	1.06	0.65	31.36	15.02	1.51
9.00	23.90	27.70	13.20	29.40	1.05	0.63	31.56	15.33	1.50
10.00	23.90	27.50	13.40	27.60	1.05	0.63	31.65	15.31	1.21
20.00	23.30	26.40	14.80	20.70	1.02	0.56	32.55	15.77	1.01
30.00	22.90	25.90	15.90	18.90	1.02	0.52	35.09	17.39	1.00
40.00	22.70	25.60	16.80	18.10	1.03	0.50	34.10	18.29	0.98
50.00	22.60	25.40	17.30	17.80	1.03	0.48	33.95	18.74	0.99
60.00	22.50	25.30	17.60	17.60	1.03	0.48	33.54	18.79	0.98
70.00	22.40	25.30	17.90	17.50	1.03	0.47	33.88	18.88	0.92
80.00	22.40	25.20	18.10	17.50	1.04	0.47	34.45	18.96	0.94
90.00	22.30	25.20	18.10	17.50	1.04	0.47	34.21	19.01	0.97
100.00	22.30	25.20	18.30	17.40	1.04	0.47	33.88	18.91	0.92
150.00	22.20	25.20	18.20	17.70	1.04	0.48	34.27	19.10	0.94
200.00	22.10	25.20	17.90	18.20	1.05	0.50	33.79	19.14	0.94
250.00	22.10	25.20	17.50	18.90	1.05	0.51	34.35	19.28	0.94
300.00	22.00	25.30	17.00	19.70	1.05	0.54	34.07	19.18	0.99
350.00	21.90	25.30	16.40	20.60	1.05	0.56	33.54	19.23	0.93
400.00	21.80	25.40	16.00	21.70	1.06	0.58	33.28	19.11	0.96
450.00	21.70	25.50	15.50	22.70	1.06	0.61	33.21	19.26	1.06
500.00	21.60	25.60	15.00	23.20	1.07	0.64	32.90	19.07	1.05
550.00	21.50	25.70	14.50	22.80	1.07	0.67	32.94	19.01	1.08
600.00	21.30	25.90	14.00	21.40	1.08	0.70	32.68	18.89	1.37
650.00	21.10	26.10	13.30	20.30	1.09	0.74	32.12	18.90	1.04
700.00	21.10	26.10	12.80	20.00	1.10	0.76	32.09	19.05	1.08
750.00	20.90	26.20	12.40	18.50	1.10	0.78	31.64	19.22	1.20
800.00	20.80	26.40	12.00	16.90	1.11	0.80	31.67	19.06	1.06
850.00	20.50	26.60	11.40	15.50	1.12	0.83	31.17	18.88	1.09
900.00	20.30	26.80	10.80	14.30	1.13	0.86	31.13	18.93	1.21
950.00	20.00	27.10	10.20	13.10	1.14	0.89	30.58	18.90	1.18
1000.00	19.70	27.40	9.50	12.00	1.16	0.92	29.66	18.78	1.23
1050.00	19.20	27.80	8.70	10.80	1.18	0.96	29.61	18.53	1.31
1100.00	18.60	28.40	7.70	9.60	1.22	1.00	29.05	18.03	1.31
1150.00	17.70	29.30	6.60	8.50	1.29	1.05	28.79	17.54	1.39
1200.00	16.40	30.50	5.50	7.60	1.42	1.10	27.41	16.58	1.48

Typical Performance Data

Definitions:

Input Return Loss = -S11 (dB)

Gain(Power Gain) = S21 (dB)

Reverse Isolation = -S12 (dB)

Output Return Loss = -S22 (dB)

TEST CONDITIONS: Vd = 2.75V, Id = 64.0952mA @ Temperature = +25°C

FREQ	Gain	Isolation	Input Return Loss	Output Return Loss	Stability		IP-3 Output	1dB Comp. Output	Noise Figure
					K	Measure			
(MHz)	(dB)	(dB)	(dB)	(dB)	K	Measure	(dBm)	(dBm)	(dB)
1.00	23.60	28.80	9.70	11.20	1.10	0.64	29.34	13.58	--
3.00	23.90	28.30	11.90	21.80	1.09	0.67	29.40	13.85	--
5.00	23.90	28.10	12.30	29.00	1.08	0.67	29.68	13.88	--
7.00	23.80	27.80	12.60	32.00	1.07	0.65	29.90	13.86	--
9.00	23.70	27.60	12.90	29.30	1.06	0.64	30.04	14.12	--
10.00	23.70	27.40	13.00	27.80	1.05	0.64	30.17	14.12	0.98
20.00	23.10	26.30	14.60	21.40	1.02	0.57	30.67	14.61	1.02
30.00	22.70	25.70	15.90	19.60	1.02	0.53	32.00	16.18	1.02
40.00	22.50	25.40	16.80	18.80	1.03	0.50	32.36	17.13	0.97
50.00	22.40	25.30	17.50	18.50	1.03	0.49	32.80	17.60	1.00
60.00	22.30	25.20	17.90	18.30	1.03	0.49	32.34	17.72	0.97
70.00	22.20	25.10	18.30	18.20	1.04	0.48	32.79	17.85	0.92
80.00	22.20	25.10	18.50	18.20	1.04	0.48	32.82	17.95	0.92
90.00	22.20	25.10	18.50	18.20	1.04	0.48	32.65	18.01	0.95
100.00	22.10	25.00	18.70	18.20	1.04	0.48	32.53	17.94	0.89
150.00	22.00	25.00	18.50	18.50	1.04	0.49	32.55	18.12	0.94
200.00	22.00	25.00	18.10	19.10	1.05	0.51	32.56	18.18	0.92
250.00	21.90	25.10	17.50	19.80	1.05	0.52	32.71	18.29	0.91
300.00	21.80	25.10	16.90	20.70	1.05	0.55	32.44	18.21	0.99
350.00	21.70	25.20	16.20	21.70	1.06	0.57	32.07	18.26	0.94
400.00	21.60	25.30	15.60	22.70	1.06	0.60	32.12	18.14	0.97
450.00	21.50	25.40	15.10	23.50	1.06	0.62	31.72	18.26	1.05
500.00	21.40	25.50	14.50	23.60	1.07	0.65	31.67	18.09	0.99
550.00	21.30	25.60	13.90	22.50	1.07	0.68	31.64	18.04	1.06
600.00	21.10	25.80	13.40	20.90	1.08	0.72	31.27	17.93	1.35
650.00	20.90	26.00	12.60	19.70	1.10	0.76	30.69	17.91	1.09
700.00	20.80	26.00	12.10	19.30	1.10	0.78	30.62	18.04	1.17
750.00	20.70	26.20	11.80	17.70	1.10	0.80	30.15	18.15	1.19
800.00	20.50	26.30	11.30	16.20	1.11	0.82	30.14	18.03	1.09
850.00	20.30	26.50	10.80	14.90	1.12	0.85	29.75	17.83	1.11
900.00	20.00	26.70	10.20	13.70	1.13	0.88	29.65	17.87	1.25
950.00	19.70	27.00	9.60	12.60	1.14	0.91	29.13	17.79	1.19
1000.00	19.30	27.40	8.90	11.50	1.16	0.94	28.27	17.52	1.25
1050.00	18.80	27.80	8.10	10.40	1.18	0.98	28.10	17.27	1.33
1100.00	18.20	28.40	7.20	9.30	1.21	1.02	27.61	16.80	1.29
1150.00	17.30	29.30	6.20	8.30	1.28	1.06	27.36	16.26	1.41
1200.00	16.00	30.50	5.20	7.50	1.41	1.11	25.96	15.30	1.47

Typical Performance Data

Definitions:

Input Return Loss = -S11 (dB)

Gain(Power Gain) = S21 (dB)

Reverse Isolation = -S12 (dB)

Output Return Loss = -S22 (dB)

TEST CONDITIONS: Vd = 3.25V, Id = 81.84666mA @ Temperature = +25°C

FREQ	Gain	Isolation	Input Return Loss	Output Return Loss	Stability		IP-3 Output	1dB Comp. Output	Noise Figure
					K	Measure			
(MHz)	(dB)	(dB)	(dB)	(dB)	K	Measure	(dBm)	(dBm)	(dB)
1.00	24.00	29.00	10.10	11.40	1.09	0.62	32.50	15.87	--
3.00	24.30	28.50	12.60	22.70	1.09	0.65	32.41	15.99	--
5.00	24.30	28.30	13.00	33.40	1.07	0.65	32.59	16.05	--
7.00	24.20	28.00	13.30	36.20	1.06	0.64	32.69	15.99	--
9.00	24.10	27.80	13.50	29.00	1.05	0.62	32.90	16.14	--
10.00	24.00	27.60	13.70	27.10	1.05	0.62	32.99	16.40	0.98
20.00	23.50	26.50	14.90	20.20	1.02	0.55	32.98	16.80	1.03
30.00	23.10	26.00	15.90	18.30	1.02	0.51	35.36	18.42	1.02
40.00	22.80	25.70	16.60	17.60	1.02	0.49	35.23	19.28	0.95
50.00	22.70	25.50	17.10	17.20	1.03	0.48	35.38	19.68	1.00
60.00	22.60	25.40	17.40	17.00	1.03	0.47	35.34	19.67	0.96
70.00	22.50	25.40	17.60	17.00	1.03	0.47	35.11	19.73	0.92
80.00	22.50	25.30	17.70	16.90	1.04	0.47	34.81	19.81	0.93
90.00	22.50	25.30	17.80	16.90	1.04	0.47	35.41	19.86	0.96
100.00	22.40	25.30	17.90	16.90	1.04	0.46	35.51	19.75	0.90
150.00	22.40	25.30	17.80	17.10	1.04	0.47	35.32	19.93	0.95
200.00	22.30	25.30	17.70	17.60	1.05	0.49	34.95	19.99	0.91
250.00	22.20	25.30	17.40	18.20	1.05	0.50	35.40	20.14	0.91
300.00	22.20	25.40	17.00	19.00	1.05	0.53	35.01	20.03	0.97
350.00	22.10	25.40	16.60	19.90	1.05	0.55	34.76	20.07	0.93
400.00	22.00	25.50	16.20	20.90	1.06	0.57	34.74	19.96	0.95
450.00	21.90	25.60	15.90	22.00	1.06	0.60	34.25	20.13	1.01
500.00	21.80	25.70	15.40	22.90	1.07	0.62	34.12	19.90	1.03
550.00	21.70	25.80	15.00	22.90	1.07	0.65	34.09	19.83	1.06
600.00	21.50	25.90	14.50	21.90	1.08	0.68	33.93	19.72	1.42
650.00	21.30	26.10	13.80	20.80	1.10	0.72	33.08	19.74	1.05
700.00	21.30	26.20	13.30	20.80	1.10	0.74	33.19	19.93	1.25
750.00	21.20	26.30	13.00	19.30	1.10	0.76	32.97	20.11	1.18
800.00	21.00	26.50	12.50	17.60	1.11	0.78	32.71	19.94	1.07
850.00	20.80	26.60	12.00	16.20	1.12	0.81	32.28	19.75	1.09
900.00	20.60	26.90	11.40	14.80	1.13	0.84	32.31	19.84	1.23
950.00	20.30	27.10	10.70	13.60	1.14	0.87	31.86	19.86	1.17
1000.00	19.90	27.50	10.00	12.40	1.16	0.91	30.95	19.78	1.22
1050.00	19.50	27.90	9.10	11.20	1.19	0.94	30.79	19.56	1.31
1100.00	18.90	28.50	8.10	10.00	1.23	0.99	30.26	19.16	1.32
1150.00	18.00	29.30	7.00	8.80	1.30	1.03	29.93	18.60	1.38
1200.00	16.70	30.60	5.80	7.80	1.43	1.09	28.69	17.69	1.45

Typical Performance Data

Definitions:

Input Return Loss = -S11 (dB)

Gain(Power Gain) = S21 (dB)

Reverse Isolation = -S12 (dB)

Output Return Loss = -S22 (dB)

TEST CONDITIONS: Vd = 3.00V, Id = 70.32125mA @ Temperature = -45°C

FREQ	Gain	Isolation	Input Return Loss	Output Return Loss	Stability		IP-3 Output	1dB Comp. Output	Noise Figure
					K	Measure			
(MHz)	(dB)	(dB)	(dB)	(dB)	K	Measure	(dBm)	(dBm)	(dB)
1.00	23.70	28.80	9.80	11.00	1.09	0.62	31.01	14.52	--
3.00	24.00	28.30	12.20	21.40	1.08	0.65	31.04	14.82	--
5.00	24.00	28.10	12.60	28.30	1.07	0.65	31.37	14.87	--
7.00	24.00	27.80	12.90	31.20	1.06	0.64	31.47	15.13	--
9.00	23.90	27.50	13.20	28.80	1.05	0.62	31.67	15.10	--
10.00	23.80	27.40	13.30	27.50	1.05	0.62	31.78	15.08	0.80
20.00	23.30	26.30	14.80	21.30	1.02	0.55	33.36	15.66	0.79
30.00	22.90	25.70	16.10	19.60	1.02	0.51	34.16	17.29	0.81
40.00	22.60	25.50	17.00	18.90	1.02	0.49	33.63	18.26	0.72
50.00	22.50	25.30	17.70	18.70	1.03	0.48	35.05	18.75	0.76
60.00	22.40	25.20	18.20	18.60	1.03	0.47	33.57	18.83	0.72
70.00	22.40	25.10	18.60	18.60	1.03	0.47	34.75	18.94	0.68
80.00	22.30	25.10	18.90	18.70	1.04	0.47	34.47	19.03	0.72
90.00	22.30	25.10	19.00	18.80	1.04	0.47	34.52	19.08	0.72
100.00	22.30	25.10	19.30	18.90	1.04	0.47	34.62	19.00	0.68
150.00	22.20	25.00	19.30	19.60	1.04	0.47	34.27	19.17	0.69
200.00	22.20	25.00	19.00	19.90	1.04	0.48	33.94	19.23	0.69
250.00	22.10	25.10	18.40	20.00	1.05	0.50	33.65	19.36	0.72
300.00	22.00	25.10	17.80	20.20	1.05	0.51	33.66	19.28	0.73
350.00	22.00	25.20	17.20	20.80	1.05	0.54	33.46	19.34	0.75
400.00	21.90	25.30	16.80	22.00	1.05	0.56	32.70	19.22	0.70
450.00	21.80	25.30	16.30	23.30	1.06	0.58	32.39	19.36	0.77
500.00	21.70	25.40	15.70	24.30	1.06	0.61	32.36	19.18	0.78
550.00	21.60	25.50	15.30	24.00	1.07	0.63	32.34	19.13	0.79
600.00	21.50	25.70	14.80	22.50	1.07	0.66	32.13	19.00	1.13
650.00	21.30	25.90	14.30	20.60	1.08	0.70	31.34	18.97	0.78
700.00	21.20	26.00	13.50	20.60	1.09	0.73	31.44	19.13	0.73
750.00	21.10	26.00	13.30	19.10	1.09	0.73	30.91	19.28	0.88
800.00	21.00	26.20	13.00	17.40	1.10	0.75	30.94	19.14	0.79
850.00	20.80	26.30	12.50	16.00	1.10	0.78	30.50	18.93	0.81
900.00	20.60	26.50	11.90	14.80	1.11	0.81	30.52	19.00	0.94
950.00	20.40	26.80	11.20	13.70	1.12	0.84	29.98	18.94	0.87
1000.00	20.10	27.10	10.40	12.60	1.14	0.87	29.36	18.72	0.93
1050.00	19.70	27.40	9.50	11.60	1.15	0.91	29.24	18.50	0.99
1100.00	19.20	27.90	8.60	10.40	1.18	0.95	28.72	18.01	0.97
1150.00	18.50	28.60	7.50	9.10	1.22	0.99	28.52	17.47	1.04
1200.00	17.40	29.70	6.30	7.90	1.31	1.04	27.13	16.37	1.06

Typical Performance Data

Definitions:

Input Return Loss = -S11 (dB)

Gain(Power Gain) = S21 (dB)

Reverse Isolation = -S12 (dB)

Output Return Loss = -S22 (dB)

TEST CONDITIONS: Vd = 2.75V, Id = 59.15511mA @ Temperature = -45°C

FREQ	Gain	Isolation	Input Return Loss	Output Return Loss	Stability		IP-3 Output	1dB Comp. Output	Noise Figure
					K	Measure			
(MHz)	(dB)	(dB)	(dB)	(dB)	K	Measure	(dBm)	(dBm)	(dB)
1.00	23.50	28.70	9.50	10.90	1.10	0.63	29.36	13.51	--
3.00	23.80	28.20	11.80	20.90	1.09	0.67	29.43	13.63	--
5.00	23.80	27.90	12.20	26.50	1.08	0.66	29.76	13.68	--
7.00	23.70	27.70	12.50	28.80	1.07	0.65	29.88	13.81	--
9.00	23.60	27.40	12.80	28.00	1.05	0.64	30.07	13.78	--
10.00	23.60	27.30	12.90	27.20	1.05	0.63	30.22	14.05	0.77
20.00	23.00	26.20	14.50	22.00	1.02	0.57	30.37	14.51	0.79
30.00	22.70	25.60	16.00	20.40	1.02	0.52	31.86	16.09	0.82
40.00	22.40	25.30	17.10	19.80	1.03	0.50	32.34	17.06	0.75
50.00	22.30	25.20	17.90	19.50	1.03	0.49	32.63	17.55	0.78
60.00	22.20	25.10	18.40	19.50	1.03	0.48	32.40	17.70	0.74
70.00	22.20	25.00	18.90	19.50	1.04	0.48	32.50	17.87	0.69
80.00	22.10	25.00	19.20	19.70	1.04	0.48	32.62	17.97	0.72
90.00	22.10	24.90	19.40	19.80	1.04	0.48	32.76	18.04	0.74
100.00	22.10	24.90	19.60	19.90	1.04	0.48	32.55	17.99	0.69
150.00	22.00	24.90	19.60	20.60	1.04	0.48	32.41	18.15	0.72
200.00	22.00	24.90	19.10	21.10	1.05	0.50	32.32	18.22	0.72
250.00	21.90	24.90	18.30	21.10	1.05	0.51	32.47	18.32	0.68
300.00	21.80	25.00	17.60	21.40	1.05	0.53	32.38	18.27	0.75
350.00	21.70	25.10	16.90	22.00	1.05	0.55	31.59	18.32	0.74
400.00	21.70	25.10	16.20	23.20	1.06	0.58	31.63	18.21	0.72
450.00	21.60	25.20	15.60	24.40	1.06	0.60	31.34	18.31	0.79
500.00	21.50	25.30	15.00	24.80	1.06	0.63	31.10	18.16	0.74
550.00	21.30	25.40	14.50	23.70	1.07	0.66	31.05	18.14	0.80
600.00	21.20	25.60	13.90	21.70	1.07	0.69	30.90	18.02	1.08
650.00	21.00	25.80	13.40	19.80	1.09	0.72	30.18	17.95	0.79
700.00	20.90	25.90	12.70	19.60	1.09	0.75	30.03	18.06	0.85
750.00	20.80	26.00	12.40	18.10	1.09	0.76	29.77	18.16	0.88
800.00	20.70	26.10	12.00	16.50	1.10	0.78	29.68	18.07	0.82
850.00	20.50	26.30	11.50	15.20	1.10	0.81	29.26	17.86	0.80
900.00	20.30	26.50	11.00	14.10	1.11	0.83	29.15	17.87	0.95
950.00	20.00	26.70	10.30	13.00	1.12	0.86	28.64	17.76	0.87
1000.00	19.70	27.00	9.60	12.10	1.13	0.90	27.90	17.44	0.92
1050.00	19.30	27.40	8.80	11.10	1.15	0.93	27.69	17.22	1.00
1100.00	18.80	27.90	7.90	10.00	1.17	0.97	27.22	16.72	0.98
1150.00	18.10	28.60	6.90	8.80	1.21	1.01	26.96	16.18	1.07
1200.00	17.00	29.70	5.80	7.60	1.29	1.06	25.56	15.14	1.14

Typical Performance Data

Definitions:

Input Return Loss = -S11 (dB)

Gain(Power Gain) = S21 (dB)

Reverse Isolation = -S12 (dB)

Output Return Loss = -S22 (dB)

TEST CONDITIONS: Vd = 3.25V, Id = 80.15761mA @ Temperature = -45°C

FREQ	Gain	Isolation	Input Return Loss	Output Return Loss	Stability		IP-3 Output	1dB Comp. Output	Noise Figure
					K	Measure			
(MHz)	(dB)	(dB)	(dB)	(dB)	K	Measure	(dBm)	(dBm)	(dB)
1.00	23.90	28.80	9.90	11.10	1.09	0.61	32.57	15.82	--
3.00	24.20	28.40	12.50	21.80	1.08	0.64	32.45	15.76	--
5.00	24.20	28.10	12.90	29.60	1.07	0.64	32.75	15.96	--
7.00	24.10	27.90	13.20	32.70	1.06	0.63	32.85	15.93	--
9.00	24.00	27.60	13.50	29.00	1.05	0.61	33.05	16.07	--
10.00	24.00	27.50	13.60	27.40	1.04	0.61	33.12	16.04	0.82
20.00	23.40	26.40	15.00	20.80	1.02	0.54	32.68	16.69	0.78
30.00	23.00	25.80	16.10	19.10	1.02	0.51	36.17	18.37	0.78
40.00	22.80	25.60	17.00	18.40	1.02	0.48	36.05	19.31	0.74
50.00	22.70	25.40	17.60	18.20	1.03	0.47	35.74	19.75	0.78
60.00	22.60	25.30	17.90	18.10	1.03	0.47	35.60	19.77	0.74
70.00	22.50	25.30	18.30	18.10	1.03	0.46	35.48	19.84	0.70
80.00	22.50	25.20	18.60	18.20	1.03	0.46	35.39	19.92	0.70
90.00	22.40	25.20	18.70	18.30	1.04	0.46	35.38	19.97	0.72
100.00	22.40	25.20	19.00	18.40	1.04	0.46	35.63	19.85	0.67
150.00	22.40	25.10	19.10	18.90	1.04	0.46	35.36	20.05	0.70
200.00	22.30	25.10	18.90	19.30	1.04	0.47	35.24	20.10	0.70
250.00	22.20	25.20	18.40	19.30	1.05	0.49	35.06	20.25	0.69
300.00	22.20	25.20	17.90	19.60	1.05	0.50	34.37	20.15	0.73
350.00	22.10	25.30	17.50	20.20	1.05	0.52	33.88	20.21	0.98
400.00	22.10	25.40	17.10	21.30	1.05	0.54	33.89	20.09	0.72
450.00	22.00	25.40	16.70	22.80	1.06	0.57	33.64	20.25	0.77
500.00	21.90	25.50	16.30	24.20	1.06	0.59	32.90	20.06	0.77
550.00	21.80	25.60	16.00	24.60	1.07	0.62	33.17	20.00	0.81
600.00	21.70	25.70	15.60	23.50	1.07	0.64	32.88	19.85	0.77
650.00	21.50	25.90	15.10	21.60	1.09	0.68	31.91	19.84	0.76
700.00	21.40	26.10	14.30	21.70	1.09	0.71	32.22	20.04	0.71
750.00	21.40	26.10	14.10	20.20	1.09	0.71	32.00	20.23	0.89
800.00	21.20	26.20	13.80	18.30	1.10	0.73	31.86	20.06	0.79
850.00	21.10	26.40	13.30	16.80	1.11	0.76	31.48	19.87	0.78
900.00	20.90	26.60	12.70	15.40	1.12	0.78	31.42	19.93	0.90
950.00	20.70	26.80	11.90	14.30	1.13	0.81	31.05	19.96	0.84
1000.00	20.40	27.10	11.10	13.10	1.14	0.85	30.40	19.85	0.90
1050.00	20.00	27.50	10.20	12.00	1.16	0.89	30.28	19.64	0.98
1100.00	19.60	28.00	9.10	10.70	1.19	0.93	29.92	19.19	0.95
1150.00	18.80	28.70	8.00	9.40	1.23	0.97	29.73	18.67	1.03
1200.00	17.70	29.80	6.70	8.10	1.33	1.02	28.49	17.60	1.08

Typical Performance Data

Definitions:

Input Return Loss = -S11 (dB)

Gain(Power Gain) = S21 (dB)

Reverse Isolation = -S12 (dB)

Output Return Loss = -S22 (dB)

TEST CONDITIONS: Vd = 3.00V, Id = 74.07835mA @ Temperature = +105°C

FREQ	Gain	Isolation	Input Return Loss	Output Return Loss	Stability		IP-3 Output	1dB Comp. Output	Noise Figure
					K	Measure			
(MHz)	(dB)	(dB)	(dB)	(dB)	K	Measure	(dBm)	(dBm)	(dB)
1.00	23.60	28.80	9.80	11.40	1.10	0.65	30.20	14.51	--
3.00	23.90	28.30	11.90	22.00	1.09	0.68	30.26	14.46	--
5.00	23.90	28.10	12.30	28.80	1.08	0.67	30.54	14.64	--
7.00	23.80	27.90	12.60	31.50	1.07	0.66	30.76	14.60	--
9.00	23.70	27.60	12.90	29.20	1.06	0.65	30.97	14.90	--
10.00	23.60	27.50	13.00	27.90	1.05	0.64	31.06	14.87	1.21
20.00	23.10	26.30	14.60	21.60	1.02	0.57	32.16	15.41	1.26
30.00	22.70	25.70	15.90	19.70	1.02	0.53	31.92	17.00	1.26
40.00	22.50	25.40	16.80	18.90	1.03	0.51	33.19	17.87	1.22
50.00	22.40	25.30	17.40	18.40	1.03	0.50	33.84	18.32	1.26
60.00	22.30	25.20	17.80	18.10	1.04	0.49	34.14	18.38	1.23
70.00	22.20	25.10	18.10	18.00	1.04	0.49	33.56	18.50	1.17
80.00	22.20	25.10	18.10	17.80	1.04	0.48	33.67	18.58	1.17
90.00	22.10	25.10	18.20	17.70	1.04	0.48	33.89	18.64	1.21
100.00	22.10	25.10	18.20	17.60	1.04	0.48	34.00	18.55	1.17
150.00	22.00	25.10	17.80	17.40	1.05	0.49	33.60	18.74	1.21
200.00	21.90	25.10	17.50	17.80	1.05	0.51	33.50	18.79	1.21
250.00	21.80	25.10	17.10	18.70	1.05	0.53	33.97	18.91	1.23
300.00	21.80	25.20	16.60	20.10	1.06	0.56	33.73	18.81	1.29
350.00	21.70	25.30	16.00	21.80	1.06	0.59	32.88	18.87	1.24
400.00	21.60	25.40	15.40	23.50	1.07	0.61	33.03	18.75	1.24
450.00	21.50	25.40	15.00	24.80	1.07	0.64	32.90	18.92	1.32
500.00	21.40	25.60	14.40	24.70	1.08	0.67	32.85	18.71	1.30
550.00	21.20	25.70	14.00	23.10	1.08	0.70	32.73	18.65	1.38
600.00	21.00	25.90	13.40	21.10	1.09	0.73	32.65	18.55	1.60
650.00	20.80	26.10	12.80	19.80	1.11	0.76	31.91	18.55	1.35
700.00	20.70	26.20	12.30	18.90	1.11	0.78	31.92	18.70	1.37
750.00	20.60	26.30	11.90	17.30	1.12	0.80	31.26	18.82	1.48
800.00	20.40	26.50	11.40	15.80	1.13	0.83	31.32	18.66	1.39
850.00	20.20	26.70	10.90	14.60	1.14	0.85	30.87	18.47	1.41
900.00	19.90	26.90	10.30	13.50	1.15	0.88	30.86	18.52	1.55
950.00	19.60	27.20	9.70	12.50	1.17	0.91	30.23	18.46	1.52
1000.00	19.20	27.60	9.00	11.50	1.19	0.94	29.41	18.25	1.58
1050.00	18.80	28.00	8.30	10.60	1.22	0.98	29.32	18.03	1.69
1100.00	18.20	28.60	7.40	9.70	1.26	1.02	28.79	17.58	1.70
1150.00	17.30	29.30	6.40	8.90	1.34	1.07	28.57	17.06	1.81
1200.00	16.30	30.40	5.50	8.30	1.46	1.13	27.39	16.30	1.88

Typical Performance Data

Definitions:

Input Return Loss = -S11 (dB)

Gain(Power Gain) = S21 (dB)

Reverse Isolation = -S12 (dB)

Output Return Loss = -S22 (dB)

TEST CONDITIONS: Vd = 2.75V, Id = 65.63857mA @ Temperature = +105°C

FREQ	Gain	Isolation	Input Return Loss	Output Return Loss	Stability		IP-3 Output	1dB Comp. Output	Noise Figure
					K	Measure			
(MHz)	(dB)	(dB)	(dB)	(dB)	K	Measure	(dBm)	(dBm)	(dB)
1.00	23.40	28.70	9.60	11.30	1.10	0.65	28.77	13.29	--
3.00	23.70	28.20	11.60	21.40	1.10	0.69	28.88	13.60	--
5.00	23.60	28.00	11.90	26.80	1.09	0.68	29.15	13.62	--
7.00	23.60	27.70	12.20	29.10	1.07	0.67	29.38	13.59	--
9.00	23.50	27.50	12.50	28.20	1.06	0.66	29.60	13.57	--
10.00	23.40	27.30	12.70	27.50	1.06	0.65	29.66	13.87	1.20
20.00	22.90	26.20	14.30	22.30	1.03	0.58	30.08	14.30	1.26
30.00	22.50	25.60	15.80	20.50	1.03	0.54	31.09	15.87	1.26
40.00	22.30	25.30	16.80	19.70	1.03	0.52	31.46	16.81	1.23
50.00	22.20	25.10	17.60	19.20	1.03	0.50	32.16	17.27	1.26
60.00	22.10	25.00	18.00	18.90	1.04	0.50	32.22	17.40	1.23
70.00	22.00	25.00	18.40	18.70	1.04	0.49	32.61	17.55	1.17
80.00	22.00	25.00	18.50	18.60	1.04	0.49	32.44	17.64	1.19
90.00	22.00	24.90	18.50	18.50	1.04	0.49	32.47	17.72	1.23
100.00	21.90	24.90	18.60	18.30	1.04	0.49	32.63	17.64	1.17
150.00	21.80	24.90	18.20	18.10	1.05	0.50	32.39	17.83	1.21
200.00	21.70	24.90	17.70	18.60	1.05	0.52	32.30	17.89	1.22
250.00	21.70	25.00	17.20	19.60	1.05	0.54	32.57	17.99	1.21
300.00	21.60	25.10	16.50	21.20	1.06	0.57	32.41	17.90	1.30
350.00	21.50	25.10	15.70	22.90	1.06	0.60	31.86	17.94	1.30
400.00	21.40	25.20	15.10	24.60	1.07	0.62	32.07	17.83	1.24
450.00	21.30	25.30	14.50	25.30	1.07	0.65	31.65	17.97	1.33
500.00	21.10	25.50	13.90	24.30	1.08	0.68	31.55	17.78	1.29
550.00	21.00	25.60	13.40	22.30	1.08	0.71	31.47	17.73	1.36
600.00	20.80	25.80	12.80	20.30	1.09	0.74	31.27	17.62	1.59
650.00	20.60	26.00	12.20	19.10	1.11	0.78	30.52	17.60	1.35
700.00	20.50	26.10	11.80	18.00	1.11	0.80	30.39	17.73	1.49
750.00	20.30	26.20	11.30	16.50	1.12	0.82	29.90	17.82	1.53
800.00	20.10	26.40	10.90	15.20	1.13	0.84	29.89	17.68	1.41
850.00	19.90	26.60	10.30	14.00	1.14	0.87	29.44	17.49	1.41
900.00	19.60	26.90	9.80	13.00	1.15	0.90	29.36	17.50	1.56
950.00	19.30	27.10	9.20	12.00	1.17	0.93	28.87	17.39	1.52
1000.00	18.90	27.50	8.60	11.10	1.19	0.96	28.05	17.13	1.61
1050.00	18.40	27.90	7.80	10.20	1.22	0.99	27.97	16.91	1.70
1100.00	17.80	28.50	7.00	9.40	1.26	1.03	27.46	16.43	1.69
1150.00	17.00	29.30	6.10	8.60	1.33	1.08	27.30	15.92	1.81
1200.00	15.90	30.30	5.20	8.10	1.45	1.14	26.05	15.14	1.90

Typical Performance Data

Definitions:

Input Return Loss = -S11 (dB)

Gain(Power Gain) = S21 (dB)

Reverse Isolation = -S12 (dB)

Output Return Loss = -S22 (dB)

TEST CONDITIONS: Vd = 3.25V, Id = 82.49949mA @ Temperature = +105°C

FREQ	Gain	Isolation	Input Return Loss	Output Return Loss	Stability		IP-3 Output	1dB Comp. Output	Noise Figure
					K	Measure			
(MHz)	(dB)	(dB)	(dB)	(dB)	K	Measure	(dBm)	(dBm)	(dB)
1.00	23.70	28.90	10.00	11.50	1.10	0.64	31.64	15.46	--
3.00	24.00	28.40	12.20	22.40	1.09	0.67	31.61	15.41	--
5.00	24.00	28.20	12.60	30.60	1.08	0.66	31.85	15.76	--
7.00	23.90	28.00	12.90	33.60	1.07	0.65	32.06	15.71	--
9.00	23.80	27.70	13.20	29.40	1.06	0.64	32.21	15.71	--
10.00	23.80	27.60	13.30	27.80	1.05	0.63	32.31	15.96	1.20
20.00	23.30	26.40	14.70	21.00	1.02	0.57	33.40	16.41	1.26
30.00	22.90	25.90	15.90	19.10	1.02	0.53	34.80	17.97	1.25
40.00	22.60	25.60	16.70	18.30	1.03	0.50	34.65	18.78	1.22
50.00	22.50	25.40	17.20	17.80	1.03	0.49	35.30	19.19	1.24
60.00	22.40	25.30	17.50	17.60	1.03	0.48	34.47	19.22	1.21
70.00	22.30	25.30	17.70	17.40	1.04	0.48	35.07	19.31	1.17
80.00	22.30	25.20	17.80	17.20	1.04	0.48	34.39	19.38	1.18
90.00	22.30	25.20	17.80	17.10	1.04	0.48	34.72	19.44	1.21
100.00	22.20	25.20	17.90	17.00	1.04	0.48	35.29	19.35	1.15
150.00	22.10	25.20	17.50	16.80	1.05	0.49	35.08	19.54	1.21
200.00	22.10	25.20	17.20	17.20	1.05	0.50	34.76	19.58	1.23
250.00	22.00	25.30	17.00	18.10	1.05	0.52	34.95	19.72	1.23
300.00	21.90	25.30	16.70	19.40	1.06	0.55	35.11	19.61	1.25
350.00	21.80	25.40	16.20	21.00	1.06	0.57	34.42	19.68	1.26
400.00	21.70	25.50	15.70	22.70	1.06	0.60	34.48	19.56	1.24
450.00	21.60	25.50	15.30	24.20	1.07	0.63	33.97	19.74	1.34
500.00	21.50	25.70	14.90	24.80	1.08	0.65	33.86	19.53	1.31
550.00	21.40	25.80	14.40	23.70	1.08	0.68	33.99	19.46	1.33
600.00	21.20	25.90	13.90	21.80	1.09	0.71	33.87	19.37	1.52
650.00	21.10	26.10	13.30	20.60	1.11	0.75	33.15	19.37	1.32
700.00	20.90	26.20	12.80	19.70	1.11	0.77	33.20	19.53	1.24
750.00	20.80	26.40	12.40	18.00	1.12	0.79	32.56	19.68	1.59
800.00	20.60	26.50	12.00	16.50	1.13	0.81	32.61	19.51	1.38
850.00	20.40	26.70	11.40	15.20	1.14	0.84	32.18	19.31	1.42
900.00	20.20	27.00	10.80	14.00	1.15	0.87	32.07	19.38	1.51
950.00	19.90	27.30	10.20	12.90	1.17	0.90	31.54	19.35	1.51
1000.00	19.50	27.60	9.50	11.90	1.20	0.93	30.68	19.19	1.58
1050.00	19.00	28.10	8.70	10.90	1.23	0.97	30.61	18.99	1.70
1100.00	18.40	28.60	7.70	9.90	1.27	1.01	30.04	18.57	1.68
1150.00	17.60	29.40	6.70	9.10	1.35	1.06	29.77	18.00	1.77
1200.00	16.60	30.40	5.70	8.40	1.48	1.12	28.66	17.27	1.90

Typical Performance Data

Definitions:

Input Return Loss = -S11 (dB)

Gain(Power Gain) = S21 (dB)

Reverse Isolation = -S12 (dB)

Output Return Loss = -S22 (dB)

TEST CONDITIONS: Vd = 5.00V, Id = 144.4664mA @ Temperature = +25°C

FREQ	Gain	Isolation	Input Return Loss	Output Return Loss	Stability		IP-3 Output	1dB Comp. Output	Noise Figure
					K	Measure			
(MHz)	(dB)	(dB)	(dB)	(dB)	K	Measure	(dBm)	(dBm)	(dB)
1.00	24.70	29.20	10.90	11.50	1.08	0.58	38.96	21.07	3.20
3.00	25.00	28.80	14.00	23.40	1.07	0.61	38.59	21.01	1.99
5.00	24.90	28.60	14.50	38.30	1.06	0.60	38.48	21.35	1.84
7.00	24.80	28.30	14.70	32.50	1.05	0.59	38.40	21.30	1.75
9.00	24.70	28.10	14.80	26.40	1.04	0.58	38.66	21.27	1.61
10.00	24.70	27.90	14.90	24.80	1.04	0.57	38.77	21.25	1.23
20.00	24.10	26.90	15.40	18.50	1.01	0.51	38.45	21.92	1.09
30.00	23.60	26.40	15.70	16.70	1.01	0.48	38.86	22.99	1.06
40.00	23.40	26.10	15.90	16.00	1.02	0.46	39.06	23.59	1.02
50.00	23.20	25.90	16.00	15.70	1.02	0.45	38.99	23.83	1.04
60.00	23.10	25.90	16.10	15.50	1.03	0.44	43.51	23.73	0.99
70.00	23.10	25.80	16.20	15.50	1.03	0.44	43.07	23.74	0.94
80.00	23.00	25.80	16.20	15.40	1.03	0.44	41.50	23.85	0.96
90.00	23.00	25.70	16.30	15.40	1.03	0.44	41.58	23.87	0.96
100.00	23.00	25.70	16.40	15.40	1.03	0.43	42.17	23.73	0.93
150.00	22.90	25.70	16.40	15.60	1.04	0.44	40.28	23.98	0.96
200.00	22.80	25.70	16.50	16.00	1.04	0.45	39.52	24.02	0.95
250.00	22.80	25.70	16.60	16.50	1.05	0.47	40.65	24.25	0.91
300.00	22.80	25.80	16.70	17.20	1.05	0.48	40.01	24.11	0.98
350.00	22.70	25.80	16.80	18.10	1.05	0.50	40.06	24.19	0.94
400.00	22.70	25.90	16.90	19.20	1.06	0.52	38.94	24.08	0.95
450.00	22.60	26.00	16.90	20.60	1.06	0.54	38.97	24.31	1.05
500.00	22.50	26.00	17.00	22.40	1.07	0.56	38.42	24.07	1.01
550.00	22.40	26.10	16.90	24.50	1.08	0.59	38.25	23.98	1.06
600.00	22.30	26.30	16.80	26.30	1.09	0.62	38.23	23.85	1.32
650.00	22.20	26.50	16.40	26.60	1.10	0.65	37.84	23.86	1.06
700.00	22.10	26.50	15.90	29.30	1.11	0.67	37.69	24.13	1.08
750.00	22.00	26.60	15.70	27.20	1.11	0.68	37.45	24.39	1.11
800.00	21.90	26.80	15.40	23.50	1.12	0.71	37.88	24.16	1.07
850.00	21.80	26.90	14.90	20.70	1.13	0.74	37.62	23.93	1.09
900.00	21.60	27.20	14.20	18.40	1.15	0.77	37.89	24.06	1.20
950.00	21.30	27.40	13.50	16.40	1.17	0.80	37.21	24.12	1.18
1000.00	21.00	27.80	12.60	14.60	1.20	0.83	36.64	24.19	1.22
1050.00	20.60	28.20	11.50	12.90	1.23	0.87	36.78	24.03	1.30
1100.00	20.00	28.90	10.30	11.30	1.29	0.92	36.53	23.73	1.27
1150.00	19.20	29.80	8.80	9.90	1.39	0.98	36.33	23.16	1.38
1200.00	17.90	31.10	7.30	8.70	1.59	1.04	35.47	22.51	1.43

Typical Performance Data

Definitions:

Input Return Loss = -S11 (dB)

Gain(Power Gain) = S21 (dB)

Reverse Isolation = -S12 (dB)

Output Return Loss = -S22 (dB)

TEST CONDITIONS: Vd = 4.75V, Id = 135.537mA @ Temperature = +25°C

FREQ	Gain	Isolation	Input Return Loss	Output Return Loss	Stability		IP-3 Output	1dB Comp. Output	Noise Figure
					K	Measure			
(MHz)	(dB)	(dB)	(dB)	(dB)	K	Measure	(dBm)	(dBm)	(dB)
1.00	24.60	29.20	10.80	11.50	1.08	0.59	38.50	20.34	--
3.00	24.90	28.80	13.80	23.40	1.07	0.61	38.02	20.59	--
5.00	24.90	28.60	14.30	37.90	1.06	0.61	37.98	20.61	--
7.00	24.80	28.30	14.50	32.70	1.05	0.60	38.06	20.59	--
9.00	24.70	28.10	14.70	26.60	1.04	0.59	38.17	20.84	--
10.00	24.60	27.90	14.70	24.90	1.04	0.58	38.29	20.82	1.10
20.00	24.00	26.90	15.30	18.60	1.01	0.52	36.63	21.35	1.07
30.00	23.60	26.30	15.70	16.80	1.01	0.48	38.31	22.54	1.08
40.00	23.30	26.10	16.00	16.10	1.02	0.46	39.57	23.12	1.01
50.00	23.20	25.90	16.10	15.80	1.02	0.45	40.85	23.38	1.03
60.00	23.10	25.80	16.20	15.60	1.03	0.44	41.07	23.28	0.97
70.00	23.00	25.80	16.30	15.50	1.03	0.44	40.63	23.29	0.93
80.00	23.00	25.70	16.40	15.50	1.03	0.44	41.18	23.39	0.93
90.00	23.00	25.70	16.40	15.50	1.03	0.44	40.45	23.42	0.96
100.00	22.90	25.70	16.50	15.50	1.03	0.44	40.71	23.28	0.91
150.00	22.90	25.70	16.50	15.60	1.04	0.44	40.89	23.53	0.94
200.00	22.80	25.70	16.60	16.10	1.04	0.46	39.33	23.57	0.90
250.00	22.80	25.70	16.70	16.60	1.05	0.47	39.71	23.79	0.92
300.00	22.70	25.80	16.80	17.30	1.05	0.49	39.97	23.64	0.92
350.00	22.60	25.80	16.80	18.20	1.05	0.51	38.91	23.73	0.92
400.00	22.60	25.90	16.80	19.20	1.06	0.52	38.71	23.61	0.95
450.00	22.50	25.90	16.90	20.60	1.06	0.55	38.26	23.83	1.04
500.00	22.50	26.00	16.90	22.40	1.07	0.57	38.16	23.59	1.00
550.00	22.40	26.10	16.80	24.20	1.08	0.59	37.87	23.50	1.06
600.00	22.30	26.20	16.60	25.50	1.08	0.62	37.92	23.36	1.34
650.00	22.10	26.40	16.20	25.40	1.10	0.66	36.91	23.38	1.05
700.00	22.00	26.50	15.60	27.30	1.10	0.68	37.52	23.63	1.09
750.00	22.00	26.60	15.40	25.50	1.11	0.69	37.27	23.90	1.20
800.00	21.80	26.70	15.10	22.50	1.12	0.71	37.14	23.66	1.06
850.00	21.70	26.90	14.60	20.00	1.13	0.74	36.77	23.43	1.08
900.00	21.50	27.10	14.00	17.90	1.15	0.77	37.29	23.56	1.21
950.00	21.20	27.40	13.20	16.00	1.17	0.81	36.83	23.64	1.17
1000.00	20.90	27.70	12.40	14.30	1.19	0.84	35.90	23.72	1.18
1050.00	20.50	28.20	11.30	12.70	1.23	0.88	35.97	23.54	1.30
1100.00	19.90	28.80	10.10	11.20	1.28	0.93	35.82	23.25	1.26
1150.00	19.00	29.70	8.60	9.70	1.38	0.98	35.62	22.68	1.37
1200.00	17.80	31.00	7.20	8.60	1.57	1.04	34.70	22.02	1.43

Typical Performance Data

Definitions:

Input Return Loss = -S11 (dB)

Gain(Power Gain) = S21 (dB)

Reverse Isolation = -S12 (dB)

Output Return Loss = -S22 (dB)

TEST CONDITIONS: Vd = 5.25V, Id = 153.2983mA @ Temperature = +25°C

FREQ	Gain	Isolation	Input Return Loss	Output Return Loss	Stability		IP-3 Output	1dB Comp. Output	Noise Figure
					K	Measure			
(MHz)	(dB)	(dB)	(dB)	(dB)	K	Measure	(dBm)	(dBm)	(dB)
1.00	24.70	29.20	11.00	11.50	1.08	0.57	39.22	21.47	--
3.00	25.00	28.80	14.10	23.40	1.07	0.60	39.13	21.72	--
5.00	25.00	28.60	14.60	38.70	1.06	0.59	38.88	21.76	--
7.00	24.90	28.30	14.80	32.40	1.05	0.59	38.86	21.73	--
9.00	24.80	28.10	14.90	26.30	1.04	0.57	39.20	21.98	--
10.00	24.70	28.00	15.00	24.70	1.03	0.57	39.29	21.94	1.10
20.00	24.10	26.90	15.40	18.40	1.01	0.51	39.32	22.44	1.10
30.00	23.70	26.40	15.70	16.70	1.01	0.47	39.66	23.39	1.07
40.00	23.40	26.10	15.80	16.00	1.02	0.46	39.56	24.04	1.00
50.00	23.30	26.00	15.90	15.70	1.02	0.44	45.27	24.25	1.05
60.00	23.20	25.90	16.00	15.50	1.03	0.44	40.24	24.15	1.00
70.00	23.10	25.80	16.10	15.40	1.03	0.44	42.36	24.14	0.92
80.00	23.10	25.80	16.10	15.40	1.03	0.43	41.99	24.28	0.96
90.00	23.00	25.80	16.20	15.40	1.03	0.43	41.72	24.30	0.98
100.00	23.00	25.80	16.30	15.30	1.03	0.43	41.46	24.15	0.91
150.00	22.90	25.70	16.30	15.50	1.04	0.44	40.87	24.41	0.94
200.00	22.90	25.80	16.40	15.90	1.04	0.45	40.68	24.45	0.91
250.00	22.80	25.80	16.50	16.40	1.04	0.46	41.44	24.68	0.94
300.00	22.80	25.80	16.70	17.20	1.05	0.48	41.05	24.54	0.98
350.00	22.70	25.90	16.70	18.00	1.05	0.50	41.26	24.63	0.95
400.00	22.70	25.90	16.90	19.10	1.06	0.52	39.21	24.52	0.97
450.00	22.60	26.00	17.00	20.50	1.06	0.54	40.22	24.75	1.05
500.00	22.60	26.10	17.00	22.40	1.07	0.56	38.46	24.52	1.02
550.00	22.50	26.20	17.00	24.80	1.08	0.58	39.37	24.44	1.04
600.00	22.40	26.30	17.00	27.10	1.09	0.61	39.48	24.31	1.42
650.00	22.20	26.50	16.60	27.90	1.10	0.65	38.50	24.33	1.02
700.00	22.20	26.60	16.10	31.70	1.11	0.66	38.69	24.59	1.14
750.00	22.10	26.60	15.90	28.90	1.11	0.68	38.26	24.86	1.18
800.00	22.00	26.80	15.60	24.40	1.12	0.70	38.54	24.63	1.05
850.00	21.80	27.00	15.10	21.20	1.14	0.73	37.97	24.40	1.08
900.00	21.60	27.20	14.40	18.70	1.15	0.76	38.61	24.54	1.21
950.00	21.40	27.50	13.70	16.60	1.17	0.79	38.05	24.59	1.16
1000.00	21.10	27.80	12.80	14.80	1.20	0.83	37.40	24.64	1.22
1050.00	20.70	28.30	11.70	13.10	1.24	0.87	37.53	24.48	1.30
1100.00	20.10	28.90	10.40	11.50	1.30	0.92	37.55	24.18	1.28
1150.00	19.20	29.80	9.00	10.00	1.41	0.97	37.47	23.63	1.39
1200.00	18.00	31.20	7.50	8.90	1.61	1.03	36.65	22.96	1.45

Typical Performance Data

Definitions:

Input Return Loss = -S11 (dB)

Gain(Power Gain) = S21 (dB)

Reverse Isolation = -S12 (dB)

Output Return Loss = -S22 (dB)

TEST CONDITIONS: Vd = 5.00V, Id = 144.1652mA @ Temperature = -45°C

FREQ	Gain	Isolation	Input Return Loss	Output Return Loss	Stability		IP-3 Output	1dB Comp. Output	Noise Figure
					K	Measure			
(MHz)	(dB)	(dB)	(dB)	(dB)	K	Measure	(dBm)	(dBm)	(dB)
1.00	24.60	29.00	10.60	11.10	1.07	0.55	36.88	20.82	--
3.00	24.90	28.50	13.90	22.30	1.07	0.58	37.96	21.07	--
5.00	24.90	28.30	14.40	31.70	1.06	0.57	38.41	21.13	--
7.00	24.80	28.10	14.70	32.50	1.04	0.56	38.72	21.09	--
9.00	24.70	27.80	14.80	27.50	1.03	0.55	38.93	21.18	--
10.00	24.60	27.70	14.90	25.90	1.03	0.55	38.98	21.15	1.09
20.00	24.00	26.70	15.70	19.50	1.01	0.50	38.38	21.78	0.88
30.00	23.60	26.20	16.10	17.80	1.01	0.47	38.03	23.14	0.84
40.00	23.30	25.90	16.50	17.20	1.02	0.45	39.05	23.84	0.78
50.00	23.20	25.70	16.80	16.90	1.02	0.44	45.16	24.08	0.82
60.00	23.10	25.70	17.00	16.90	1.03	0.43	40.47	23.95	0.77
70.00	23.00	25.60	17.20	16.90	1.03	0.43	43.76	23.93	0.70
80.00	23.00	25.60	17.30	16.90	1.03	0.43	43.49	24.07	0.71
90.00	23.00	25.50	17.50	17.00	1.03	0.43	43.65	24.09	0.74
100.00	22.90	25.50	17.70	17.10	1.03	0.43	44.09	23.92	0.69
150.00	22.90	25.50	17.90	17.50	1.04	0.43	43.44	24.19	0.73
200.00	22.80	25.50	17.90	17.80	1.04	0.44	41.97	24.22	0.68
250.00	22.80	25.50	17.70	17.80	1.04	0.45	42.22	24.48	0.68
300.00	22.70	25.60	17.60	18.10	1.05	0.46	42.42	24.31	0.74
350.00	22.70	25.60	17.60	18.70	1.05	0.48	42.19	24.39	0.72
400.00	22.70	25.70	17.70	19.90	1.05	0.49	40.81	24.27	0.73
450.00	22.60	25.70	17.90	21.50	1.06	0.51	42.73	24.53	0.74
500.00	22.60	25.80	18.00	23.90	1.06	0.53	40.23	24.28	0.81
550.00	22.50	25.90	18.20	27.30	1.07	0.55	40.37	24.19	0.82
600.00	22.40	26.00	18.30	33.50	1.08	0.58	41.27	24.05	1.05
650.00	22.30	26.20	18.30	37.50	1.09	0.61	39.86	24.05	0.78
700.00	22.20	26.30	17.50	40.40	1.10	0.64	41.01	24.36	0.74
750.00	22.20	26.40	17.50	28.50	1.10	0.64	40.49	24.68	0.87
800.00	22.10	26.50	17.30	23.90	1.11	0.66	41.06	24.42	0.79
850.00	22.00	26.70	16.80	20.90	1.12	0.68	41.08	24.19	0.77
900.00	21.80	26.90	16.10	18.60	1.13	0.71	42.10	24.36	0.95
950.00	21.60	27.10	15.20	16.70	1.15	0.74	40.65	24.49	0.87
1000.00	21.40	27.50	14.20	15.00	1.17	0.77	40.38	24.67	0.90
1050.00	21.00	27.90	12.90	13.40	1.20	0.81	40.92	24.51	0.99
1100.00	20.60	28.40	11.60	11.90	1.25	0.86	41.00	24.25	0.95
1150.00	19.90	29.20	10.10	10.30	1.33	0.91	41.72	23.70	1.05
1200.00	18.70	30.40	8.40	8.80	1.49	0.97	40.89	23.11	1.10

Typical Performance Data

Definitions:

Input Return Loss = -S11 (dB)

Gain(Power Gain) = S21 (dB)

Reverse Isolation = -S12 (dB)

Output Return Loss = -S22 (dB)

TEST CONDITIONS: Vd = 4.75V, Id = 135.3563mA @ Temperature = -45°C

FREQ	Gain	Isolation	Input Return Loss	Output Return Loss	Stability		IP-3 Output	1dB Comp. Output	Noise Figure
					K	Measure			
(MHz)	(dB)	(dB)	(dB)	(dB)	K	Measure	(dBm)	(dBm)	(dB)
1.00	24.50	29.00	10.60	11.10	1.07	0.56	36.21	20.40	--
3.00	24.80	28.50	13.70	22.30	1.07	0.59	36.99	20.49	--
5.00	24.80	28.30	14.20	31.70	1.06	0.58	37.38	20.55	--
7.00	24.70	28.00	14.50	32.80	1.05	0.57	37.65	20.51	--
9.00	24.60	27.80	14.70	27.70	1.04	0.56	37.90	20.78	--
10.00	24.50	27.70	14.80	26.00	1.03	0.56	38.11	20.74	1.01
20.00	23.90	26.70	15.60	19.60	1.01	0.50	39.82	21.21	0.85
30.00	23.50	26.10	16.10	17.90	1.01	0.47	38.40	22.68	0.82
40.00	23.30	25.90	16.60	17.30	1.02	0.45	41.88	23.34	0.76
50.00	23.10	25.70	16.90	17.00	1.02	0.44	42.06	23.62	0.78
60.00	23.00	25.60	17.10	17.00	1.03	0.44	42.59	23.49	0.72
70.00	23.00	25.60	17.30	17.00	1.03	0.43	41.54	23.49	0.71
80.00	22.90	25.50	17.50	17.00	1.03	0.43	42.70	23.60	0.72
90.00	22.90	25.50	17.60	17.10	1.03	0.43	40.87	23.63	0.73
100.00	22.90	25.50	17.80	17.20	1.03	0.43	41.46	23.46	0.68
150.00	22.80	25.50	18.00	17.70	1.04	0.43	42.09	23.73	0.69
200.00	22.80	25.50	18.10	17.90	1.04	0.44	41.48	23.76	0.70
250.00	22.70	25.50	17.90	17.90	1.04	0.45	41.24	24.00	0.70
300.00	22.70	25.50	17.70	18.20	1.05	0.46	40.45	23.83	0.73
350.00	22.60	25.60	17.70	18.90	1.05	0.48	40.48	23.92	0.71
400.00	22.60	25.60	17.80	20.10	1.05	0.50	40.07	23.79	0.71
450.00	22.60	25.70	17.90	21.70	1.06	0.51	39.44	24.04	0.74
500.00	22.50	25.80	18.00	24.10	1.06	0.53	38.30	23.79	0.75
550.00	22.40	25.90	18.20	27.60	1.07	0.56	39.58	23.70	0.81
600.00	22.40	26.00	18.20	33.00	1.08	0.58	39.26	23.56	1.02
650.00	22.20	26.20	18.10	33.70	1.09	0.61	38.11	23.54	0.77
700.00	22.10	26.30	17.30	35.80	1.10	0.64	38.38	23.84	0.81
750.00	22.10	26.30	17.30	28.10	1.10	0.64	38.78	24.15	0.93
800.00	22.00	26.50	17.10	23.60	1.11	0.66	38.31	23.91	0.76
850.00	21.90	26.60	16.60	20.70	1.12	0.68	38.04	23.67	0.79
900.00	21.80	26.90	15.90	18.50	1.13	0.71	38.85	23.83	0.90
950.00	21.60	27.10	15.00	16.60	1.15	0.74	38.24	23.95	0.86
1000.00	21.30	27.40	14.00	15.00	1.17	0.78	37.56	24.13	0.91
1050.00	21.00	27.80	12.80	13.40	1.20	0.81	38.09	23.96	0.95
1100.00	20.50	28.30	11.50	11.80	1.24	0.86	38.29	23.68	0.95
1150.00	19.80	29.10	10.00	10.30	1.32	0.91	37.97	23.14	1.02
1200.00	18.70	30.40	8.30	8.80	1.47	0.97	37.86	22.51	1.05

Typical Performance Data

Definitions:

Input Return Loss = -S11 (dB)

Gain(Power Gain) = S21 (dB)

Reverse Isolation = -S12 (dB)

Output Return Loss = -S22 (dB)

TEST CONDITIONS: Vd = 5.25V, Id = 153.272mA @ Temperature = -45°C

FREQ	Gain	Isolation	Input Return Loss	Output Return Loss	Stability		IP-3 Output	1dB Comp. Output	Noise Figure
					K	Measure			
(MHz)	(dB)	(dB)	(dB)	(dB)			(dBm)	(dBm)	(dB)
1.00	24.60	29.00	10.70	11.10	1.07	0.54	37.52	21.38	--
3.00	25.00	28.50	14.00	22.30	1.06	0.57	39.07	21.49	--
5.00	24.90	28.30	14.50	31.80	1.05	0.57	39.58	21.54	--
7.00	24.80	28.10	14.80	32.40	1.04	0.56	39.65	21.63	--
9.00	24.70	27.80	15.00	27.40	1.03	0.55	40.16	21.74	--
10.00	24.70	27.70	15.00	25.70	1.03	0.54	40.28	21.72	1.13
20.00	24.00	26.70	15.70	19.40	1.01	0.49	40.35	22.33	0.92
30.00	23.60	26.20	16.10	17.70	1.01	0.46	40.53	23.56	0.84
40.00	23.40	25.90	16.40	17.10	1.02	0.45	41.56	24.32	0.79
50.00	23.20	25.80	16.70	16.80	1.02	0.44	42.91	24.52	0.79
60.00	23.10	25.70	16.90	16.80	1.02	0.43	43.82	24.38	0.75
70.00	23.10	25.60	17.10	16.80	1.03	0.43	42.66	24.34	0.69
80.00	23.00	25.60	17.20	16.80	1.03	0.43	42.52	24.52	0.72
90.00	23.00	25.60	17.30	16.90	1.03	0.43	43.72	24.52	0.74
100.00	23.00	25.60	17.50	17.00	1.03	0.43	44.38	24.36	0.69
150.00	22.90	25.50	17.70	17.40	1.04	0.43	43.50	24.63	0.71
200.00	22.90	25.50	17.80	17.60	1.04	0.44	43.16	24.67	0.70
250.00	22.80	25.60	17.60	17.70	1.04	0.45	44.98	24.93	0.69
300.00	22.80	25.60	17.50	18.00	1.05	0.46	43.63	24.76	0.74
350.00	22.70	25.70	17.50	18.60	1.05	0.47	45.42	24.84	0.71
400.00	22.70	25.70	17.60	19.70	1.05	0.49	42.72	24.72	0.71
450.00	22.70	25.80	17.80	21.30	1.06	0.51	43.56	24.99	0.76
500.00	22.60	25.80	18.00	23.60	1.06	0.53	42.98	24.75	0.75
550.00	22.50	25.90	18.20	26.90	1.07	0.55	42.28	24.66	0.83
600.00	22.50	26.00	18.40	33.00	1.08	0.57	43.73	24.52	1.02
650.00	22.30	26.20	18.40	41.20	1.09	0.61	42.20	24.54	0.75
700.00	22.20	26.40	17.50	44.20	1.10	0.63	43.50	24.85	0.87
750.00	22.20	26.40	17.60	28.70	1.10	0.63	44.15	25.17	0.85
800.00	22.10	26.50	17.40	24.00	1.11	0.65	42.70	24.92	0.80
850.00	22.00	26.70	16.90	21.00	1.12	0.68	43.88	24.70	0.78
900.00	21.90	26.90	16.20	18.70	1.13	0.71	45.37	24.87	0.93
950.00	21.70	27.20	15.30	16.70	1.15	0.74	45.00	25.00	0.85
1000.00	21.40	27.50	14.30	15.10	1.17	0.77	43.01	25.19	0.94
1050.00	21.10	27.90	13.00	13.50	1.21	0.81	43.19	25.03	0.99
1100.00	20.60	28.40	11.70	11.90	1.25	0.85	45.43	24.78	0.96
1150.00	19.90	29.30	10.10	10.30	1.34	0.91	47.30	24.23	1.03
1200.00	18.70	30.50	8.50	8.90	1.50	0.97	43.68	23.65	1.05

Typical Performance Data

Definitions:

Input Return Loss = -S11 (dB)

Gain(Power Gain) = S21 (dB)

Reverse Isolation = -S12 (dB)

Output Return Loss = -S22 (dB)

TEST CONDITIONS: Vd = 5.00V, Id = 140.0543mA @ Temperature = +105°C

FREQ	Gain	Isolation	Input Return Loss	Output Return Loss	Stability		IP-3 Output	1dB Comp. Output	Noise Figure
					K	Measure			
(MHz)	(dB)	(dB)	(dB)	(dB)	K	Measure	(dBm)	(dBm)	(dB)
1.00	24.40	29.20	10.90	11.70	1.09	0.60	38.00	20.33	--
3.00	24.70	28.70	13.70	23.50	1.08	0.63	36.88	20.29	--
5.00	24.70	28.50	14.20	37.50	1.07	0.63	36.74	20.63	--
7.00	24.60	28.30	14.40	34.60	1.06	0.61	36.78	20.59	--
9.00	24.50	28.00	14.50	27.60	1.05	0.60	36.82	20.56	--
10.00	24.40	27.90	14.60	25.80	1.04	0.60	36.93	20.83	1.30
20.00	23.80	26.80	15.30	19.20	1.02	0.54	37.06	21.18	1.33
30.00	23.40	26.30	15.70	17.40	1.02	0.50	37.48	22.22	1.32
40.00	23.20	26.00	16.00	16.60	1.02	0.48	38.05	22.77	1.29
50.00	23.00	25.90	16.10	16.20	1.03	0.47	38.02	23.08	1.32
60.00	22.90	25.80	16.20	15.90	1.03	0.46	39.71	23.09	1.25
70.00	22.90	25.70	16.20	15.80	1.03	0.46	38.96	23.16	1.21
80.00	22.80	25.70	16.20	15.60	1.04	0.46	39.94	23.25	1.25
90.00	22.80	25.70	16.10	15.50	1.04	0.46	39.10	23.30	1.27
100.00	22.80	25.70	16.20	15.40	1.04	0.45	39.54	23.20	1.24
150.00	22.70	25.70	15.80	15.20	1.04	0.46	39.75	23.41	1.26
200.00	22.60	25.70	15.90	15.60	1.05	0.47	39.12	23.46	1.22
250.00	22.60	25.70	16.10	16.30	1.05	0.49	39.46	23.61	1.24
300.00	22.50	25.80	16.30	17.50	1.06	0.51	38.80	23.54	1.31
350.00	22.40	25.80	16.40	18.90	1.06	0.53	38.66	23.64	1.32
400.00	22.40	25.90	16.50	20.60	1.07	0.55	38.99	23.54	1.31
450.00	22.30	25.90	16.60	22.60	1.07	0.58	38.48	23.73	1.37
500.00	22.20	26.00	16.50	25.10	1.08	0.60	38.51	23.53	1.35
550.00	22.10	26.10	16.50	27.60	1.09	0.62	38.93	23.49	1.39
600.00	22.00	26.30	16.20	28.30	1.10	0.65	38.71	23.40	1.62
650.00	21.90	26.50	15.70	27.60	1.11	0.69	38.20	23.37	1.39
700.00	21.80	26.60	15.30	26.70	1.12	0.70	38.21	23.54	1.35
750.00	21.70	26.70	15.00	23.40	1.13	0.72	37.65	23.67	1.54
800.00	21.50	26.80	14.60	20.60	1.14	0.74	38.02	23.53	1.45
850.00	21.40	27.10	14.00	18.40	1.16	0.77	37.56	23.27	1.45
900.00	21.10	27.30	13.30	16.60	1.18	0.80	38.11	23.35	1.60
950.00	20.90	27.60	12.60	15.10	1.20	0.83	37.28	23.27	1.53
1000.00	20.50	28.00	11.70	13.70	1.23	0.87	36.32	23.06	1.63
1050.00	20.10	28.50	10.70	12.40	1.27	0.91	36.34	22.89	1.70
1100.00	19.50	29.10	9.50	11.20	1.34	0.96	36.01	22.48	1.74
1150.00	18.70	29.90	8.30	10.10	1.45	1.01	35.75	22.00	1.83
1200.00	17.60	31.00	7.00	9.40	1.63	1.07	34.71	21.27	1.94

Typical Performance Data

Definitions:

Input Return Loss = -S11 (dB)

Gain(Power Gain) = S21 (dB)

Reverse Isolation = -S12 (dB)

Output Return Loss = -S22 (dB)

TEST CONDITIONS: Vd = 4.75V, Id = 132.2049mA @ Temperature = +105°C

FREQ	Gain	Isolation	Input Return Loss	Output Return Loss	Stability		IP-3 Output	1dB Comp. Output	Noise Figure
					K	Measure			
(MHz)	(dB)	(dB)	(dB)	(dB)	K	Measure	(dBm)	(dBm)	(dB)
1.00	24.40	29.20	10.80	11.70	1.09	0.61	37.58	19.78	--
3.00	24.60	28.70	13.50	23.40	1.08	0.64	36.55	19.74	--
5.00	24.60	28.50	14.00	37.20	1.07	0.63	36.35	20.10	--
7.00	24.50	28.30	14.20	34.90	1.06	0.62	36.51	20.06	--
9.00	24.40	28.00	14.40	27.80	1.05	0.61	36.63	20.02	--
10.00	24.40	27.90	14.50	26.00	1.04	0.60	36.70	20.30	1.26
20.00	23.80	26.80	15.30	19.30	1.02	0.54	36.31	20.69	1.32
30.00	23.40	26.30	15.80	17.50	1.02	0.50	38.59	21.80	1.30
40.00	23.10	26.00	16.10	16.70	1.02	0.48	39.52	22.36	1.25
50.00	23.00	25.80	16.20	16.30	1.03	0.47	38.22	22.68	1.30
60.00	22.90	25.70	16.30	16.00	1.03	0.46	38.48	22.67	1.23
70.00	22.80	25.70	16.40	15.80	1.03	0.46	39.51	22.74	1.20
80.00	22.80	25.70	16.30	15.70	1.04	0.46	39.86	22.83	1.23
90.00	22.70	25.60	16.30	15.60	1.04	0.46	39.14	22.88	1.26
100.00	22.70	25.60	16.30	15.50	1.04	0.46	39.36	22.77	1.21
150.00	22.60	25.60	16.00	15.30	1.04	0.46	39.40	22.99	1.26
200.00	22.60	25.60	16.00	15.70	1.05	0.48	38.74	23.03	1.23
250.00	22.50	25.70	16.20	16.40	1.05	0.49	38.89	23.19	1.25
300.00	22.50	25.70	16.40	17.60	1.06	0.51	38.60	23.11	1.30
350.00	22.40	25.80	16.50	19.00	1.06	0.54	38.29	23.20	1.32
400.00	22.30	25.80	16.50	20.60	1.06	0.56	38.14	23.11	1.28
450.00	22.30	25.90	16.50	22.60	1.07	0.58	38.66	23.30	1.37
500.00	22.20	26.00	16.40	25.00	1.08	0.60	38.34	23.09	1.35
550.00	22.10	26.10	16.30	27.00	1.09	0.63	37.76	23.05	1.40
600.00	21.90	26.30	16.00	27.00	1.10	0.66	38.32	22.95	1.59
650.00	21.80	26.40	15.50	26.10	1.11	0.69	37.78	22.93	1.37
700.00	21.70	26.50	15.10	25.40	1.12	0.71	37.49	23.12	1.39
750.00	21.60	26.60	14.80	22.60	1.13	0.73	37.46	23.26	1.49
800.00	21.50	26.80	14.30	20.10	1.14	0.75	37.63	23.10	1.40
850.00	21.30	27.00	13.70	18.10	1.15	0.78	37.11	22.86	1.45
900.00	21.10	27.30	13.10	16.40	1.17	0.81	37.22	22.94	1.59
950.00	20.80	27.60	12.30	14.90	1.20	0.84	36.68	22.88	1.56
1000.00	20.50	27.90	11.50	13.50	1.23	0.87	35.92	22.71	1.62
1050.00	20.00	28.40	10.50	12.20	1.27	0.91	35.74	22.53	1.70
1100.00	19.40	29.00	9.30	11.10	1.33	0.96	35.24	22.13	1.71
1150.00	18.60	29.90	8.10	10.00	1.44	1.02	35.03	21.63	1.81
1200.00	17.60	31.00	6.90	9.30	1.61	1.08	33.93	20.92	1.90

Typical Performance Data

Definitions:

Input Return Loss = -S11 (dB)

Gain(Power Gain) = S21 (dB)

Reverse Isolation = -S12 (dB)

Output Return Loss = -S22 (dB)

TEST CONDITIONS: Vd = 5.25V, Id = 147.7153mA @ Temperature = +105°C

FREQ	Gain	Isolation	Input Return Loss	Output Return Loss	Stability		IP-3 Output	1dB Comp. Output	Noise Figure
					K	Measure			
(MHz)	(dB)	(dB)	(dB)	(dB)	K	Measure	(dBm)	(dBm)	(dB)
1.00	24.50	29.20	11.00	11.70	1.09	0.60	38.56	20.84	--
3.00	24.70	28.80	13.90	23.50	1.08	0.63	37.13	20.83	--
5.00	24.70	28.50	14.30	37.70	1.07	0.62	36.83	21.18	--
7.00	24.60	28.30	14.60	34.40	1.06	0.61	37.02	21.12	--
9.00	24.50	28.10	14.70	27.50	1.05	0.60	37.06	21.08	--
10.00	24.50	27.90	14.80	25.70	1.04	0.59	37.14	21.36	1.32
20.00	23.90	26.90	15.40	19.20	1.02	0.53	36.83	21.65	1.38
30.00	23.50	26.30	15.70	17.30	1.02	0.50	38.23	22.63	1.35
40.00	23.20	26.00	15.90	16.60	1.02	0.48	37.94	23.19	1.29
50.00	23.10	25.90	16.00	16.20	1.03	0.47	38.29	23.48	1.34
60.00	23.00	25.80	16.00	15.90	1.03	0.46	39.28	23.49	1.28
70.00	22.90	25.80	16.10	15.70	1.03	0.46	40.82	23.56	1.22
80.00	22.90	25.70	16.00	15.60	1.04	0.46	39.90	23.67	1.25
90.00	22.80	25.70	16.00	15.50	1.04	0.45	40.04	23.71	1.29
100.00	22.80	25.70	16.00	15.40	1.04	0.45	40.35	23.61	1.24
150.00	22.70	25.70	15.70	15.20	1.04	0.46	40.13	23.83	1.27
200.00	22.60	25.70	15.70	15.50	1.05	0.47	39.70	23.88	1.27
250.00	22.60	25.70	16.00	16.30	1.05	0.49	39.52	24.02	1.29
300.00	22.50	25.80	16.20	17.40	1.06	0.51	39.72	23.96	1.32
350.00	22.50	25.80	16.40	18.80	1.06	0.53	38.88	24.05	1.31
400.00	22.40	25.90	16.50	20.50	1.07	0.55	39.30	23.97	1.30
450.00	22.40	26.00	16.60	22.60	1.07	0.57	39.09	24.14	1.39
500.00	22.30	26.10	16.60	25.20	1.08	0.60	39.03	23.95	1.41
550.00	22.20	26.20	16.60	28.30	1.09	0.62	38.97	23.92	1.42
600.00	22.10	26.30	16.40	29.70	1.10	0.65	39.13	23.84	1.61
650.00	21.90	26.50	15.90	29.20	1.12	0.68	38.21	23.79	1.40
700.00	21.80	26.60	15.50	28.00	1.12	0.70	38.82	23.97	1.37
750.00	21.70	26.70	15.20	24.00	1.13	0.72	38.44	24.07	1.57
800.00	21.60	26.90	14.80	21.00	1.14	0.74	38.75	23.95	1.46
850.00	21.40	27.10	14.20	18.70	1.16	0.77	38.10	23.69	1.49
900.00	21.20	27.40	13.50	16.80	1.18	0.80	38.28	23.76	1.60
950.00	20.90	27.70	12.80	15.20	1.20	0.83	37.94	23.65	1.59
1000.00	20.60	28.00	11.90	13.80	1.24	0.86	37.01	23.40	1.66
1050.00	20.20	28.50	10.80	12.50	1.28	0.90	37.17	23.25	1.75
1100.00	19.60	29.10	9.70	11.30	1.35	0.95	36.71	22.83	1.73
1150.00	18.80	30.00	8.40	10.20	1.47	1.01	36.55	22.36	1.84
1200.00	17.70	31.10	7.10	9.60	1.66	1.07	35.43	21.61	1.95

MMIC Amplifier

LHA-13LN+

Typical Performance Curves

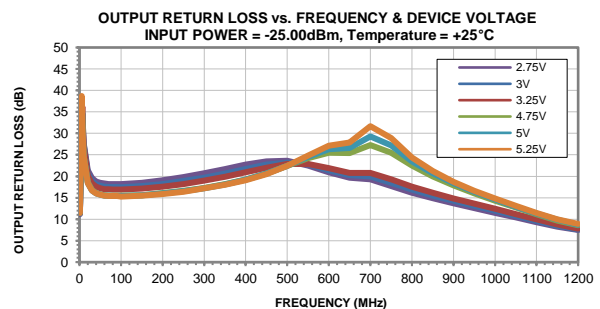
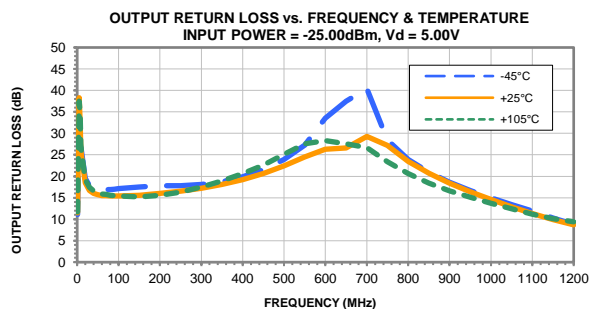
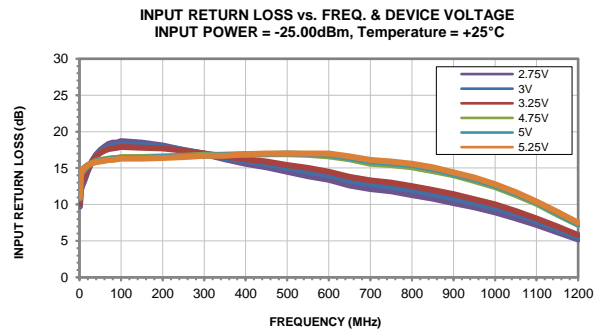
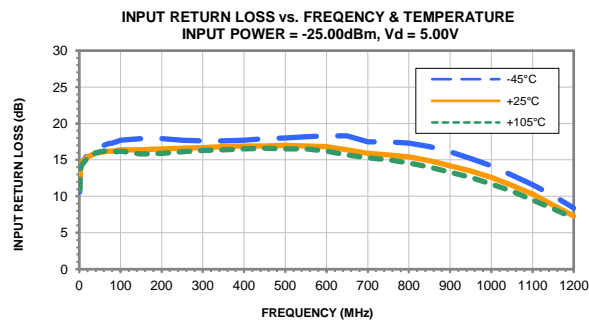
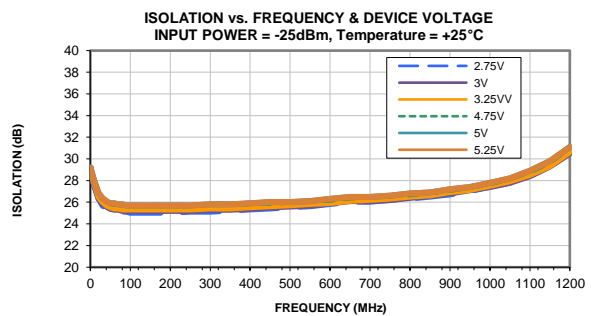
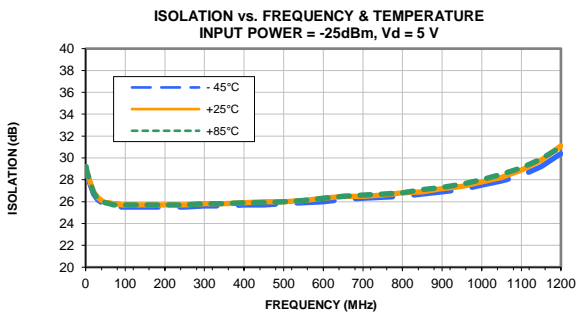
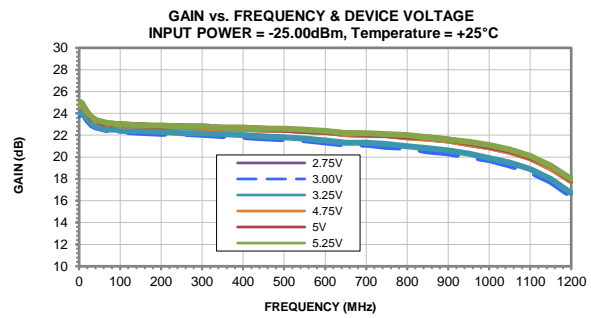
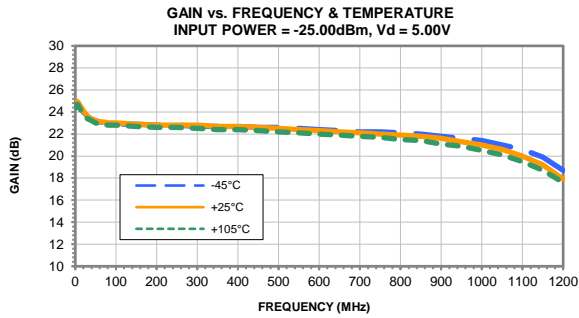

Typical Performance Curves

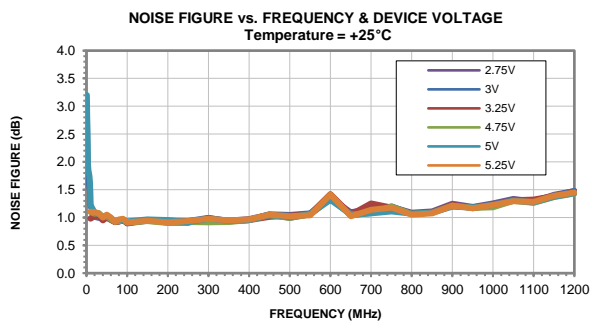
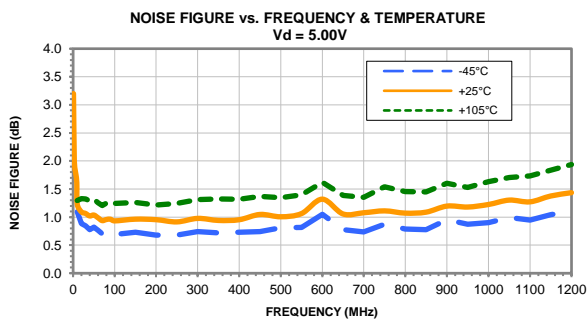
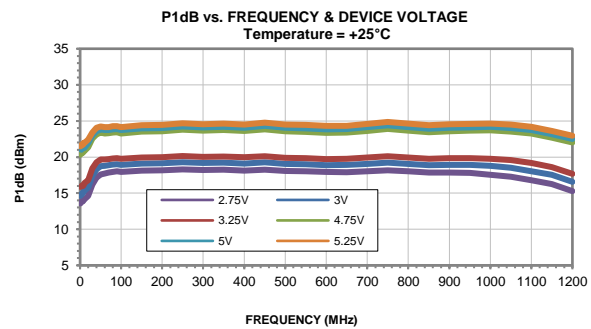
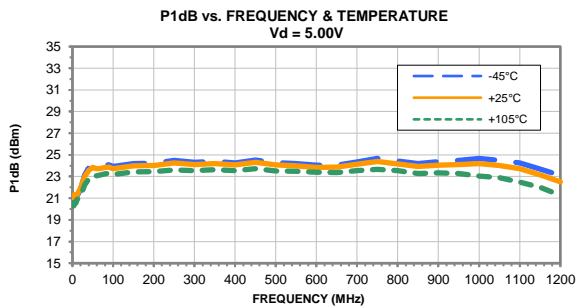
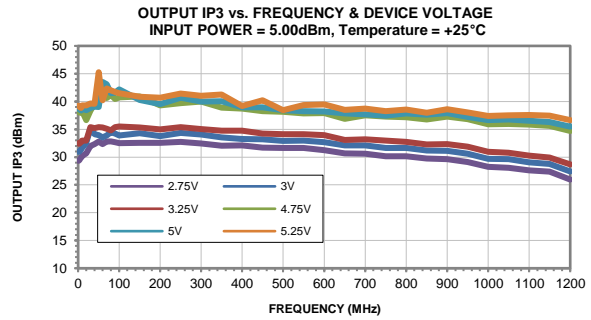
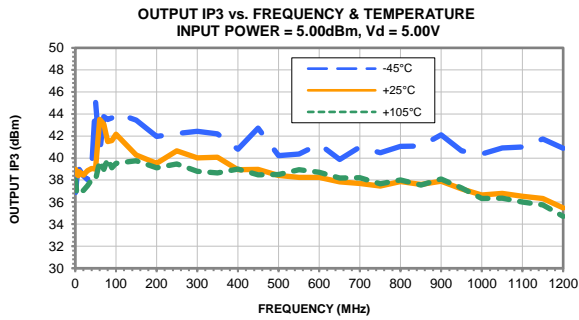

Outline Dimensions



PCB Land Pattern

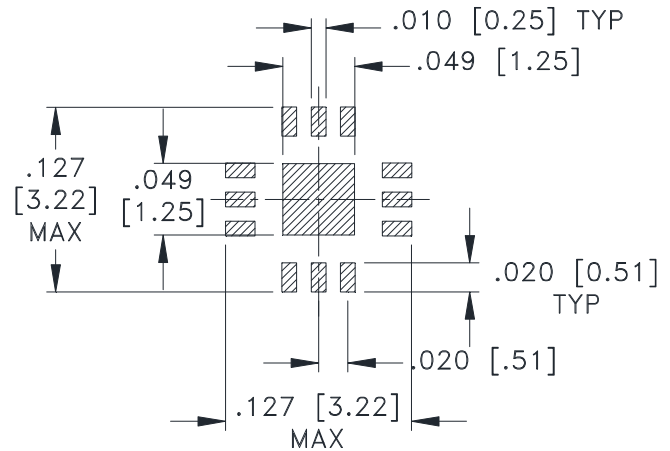

SUGGESTED LAYOUT,
TOLERANCE TO BE WITHIN $\pm .002$

Weight: .02 Grams

Dimensions are in inches (mm). Tolerances: 2Pl. $\pm .01$; 3 Pl. $\pm .004$

Notes:

1. Case material: Plastic.
2. Termination finish:
 - For RoHS Case Styles: Tin-Silver alloy plate over Nickel barrier or Matte-Tin. All models, (+) suffix. See Data sheet.
 - For RoHS-5 Case Styles: Tin-Lead plate. All models, no (+) suffix.

Tape & Reel Packaging TR-F66



Tape Width, mm	Device Cavity Pitch, mm	Reel Size, inches	Devices per Reel see note	
8	4	7	Small quantity standard	20
				50
				100
				200
				500
		7	Standard	1000, 2000, 3000

Note: Please consult individual model data sheet to determine device per reel availability.

Mini-Circuits carrier tape materials provide protection from ESD (Electro-Static Discharge) during handling and transportation. Tapes are static dissipative and comply with industry standards EIA-481/EIA-541.

Go to: www.minicircuits.com/pages/pdfs/tape.pdf

Mini-Circuits®

INTERNET <http://www.minicircuits.com>

P.O. Box 350166, Brooklyn, New York 11235-0003 (718) 934-4500 Fax (718) 332-4661

Distribution Centers NORTH AMERICA 800-654-7949 • 417-335-5935 • Fax 417-335-5945 • EUROPE 44-1252-832600 • Fax 44-1252-837010

Mini-Circuits ISO 9001 & ISO 14001 Certified

THIRD ANGLE PROJECTION

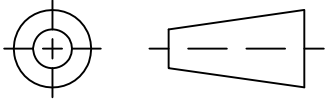

REVISIONS

REV	ECN No.	DESCRIPTION	DATE	DR	AUTH
OR	M168912	NEW RELEASE	08/02/18	ITG	RS

SUGGESTED MOUNTING CONFIGURATION
FOR DQ1225 CASE STYLE, "12AM03" PIN CODE

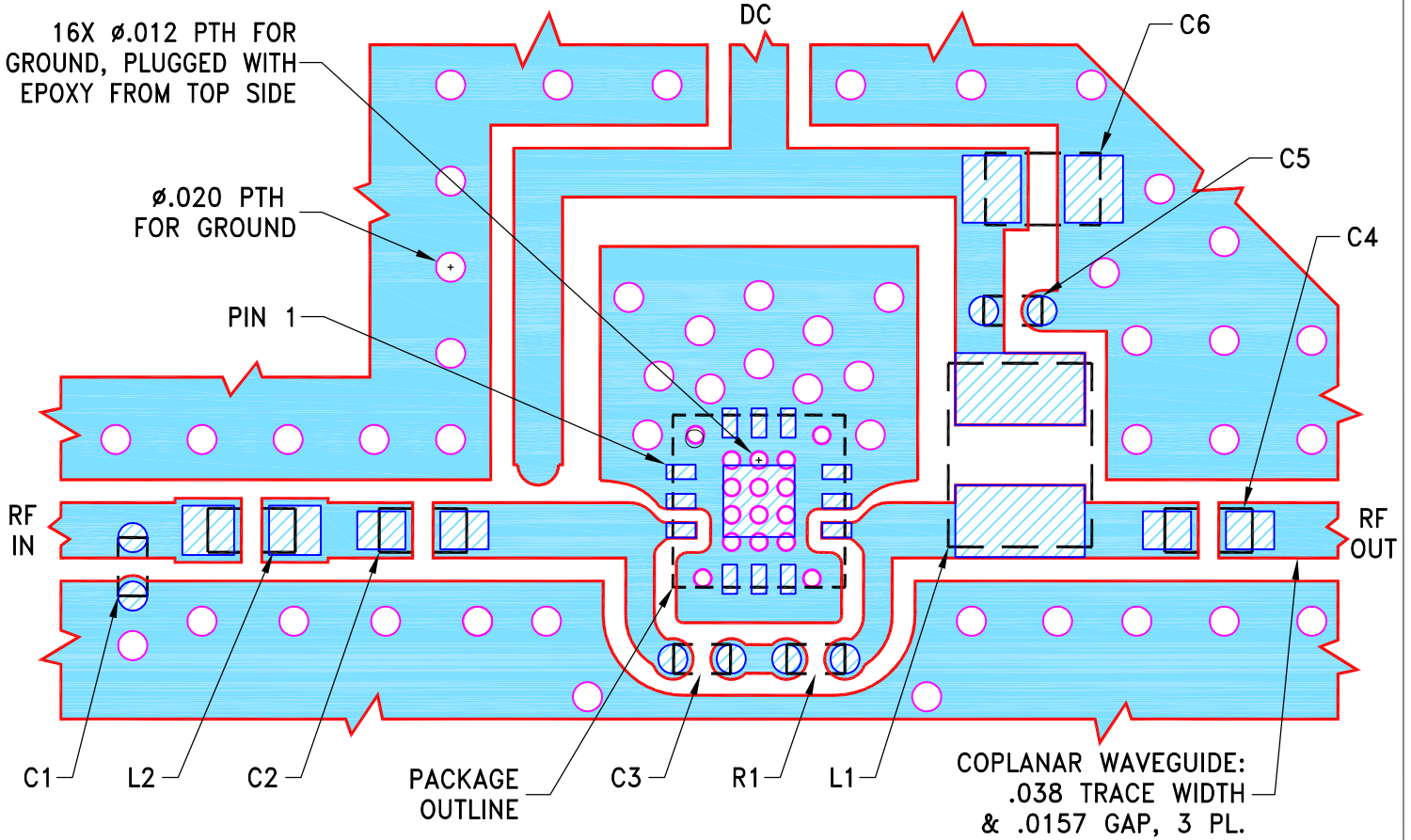

COMPONENT	SIZE
R1,C1,C3,C5	0402
L2,C2,C4	0603
L1	1210

NOTES:

1. TRACE WIDTH & GAP PARAMETERS ARE SHOWN FOR ROGERS R04350B WITH DIELECTRIC THICKNESS .020"±.0015". COPPER: 1/2 OZ. EACH SIDE. FOR OTHER MATERIALS TRACE WIDTH & GAP MAY NEED TO BE MODIFIED.
2. CHIP COMPONENT FOOT PRINTS SHOWN FOR REFERENCE. FOR COMPONENT VALUES REFER TO TB-1063-13LN+.
3. BOTTOM SIDE OF THE PCB IS CONTINUOUS GROUND PLANE.



DENOTES PCB COPPER LAYOUT WITH SMOBC (SOLDER MASK OVER BARE COPPER).

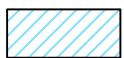

DENOTES COPPER LAND PATTERN FREE OF SOLDER MASK.

UNLESS OTHERWISE SPECIFIED	INITIALS	DATE
DIMENSIONS ARE IN INCHES	DRAWN ITG	07/12/18
TOLERANCES ON:	CHECKED GF	08/02/18
2 PL DECIMALS ±	APPROVED RS	08/02/18
3 PL DECIMALS ± .005		
ANGLES ±		
FRACTIONS ±		



Mini-Circuits®

13 Neptune Avenue
Brooklyn NY 11235

PL, 12AM03, DQ1225, TB-1063-13LN+

SIZE	CODE IDENT	DRAWING NO:	REV:
A	15542	98-PL-594	OR
FILE:	98PL594	SCALE: 8:1	SHEET: 1 OF 1

THIS DOCUMENT AND ITS CONTENTS ARE THE PROPERTY OF MINI-CIRCUITS. EXCEPT FOR USE EXPRESSLY GRANTED, IN WRITING, TO ITS VENDORS, VENDEE AND THE UNITED STATES GOVERNMENT, MINI-CIRCUITS RESERVES ALL PROPRIETARY DESIGN, USE, MANUFACTURING AND REPRODUCTION RIGHTS THERETO. THESE CONTENTS SHALL NOT BE USED, DUPLICATED OR DISCLOSED TO ANY OUTSIDE PARTY, IN WHOLE OR IN PART, WITHOUT WRITTEN PERMISSION OF MINI-CIRCUITS.

Evaluation Board and Circuit

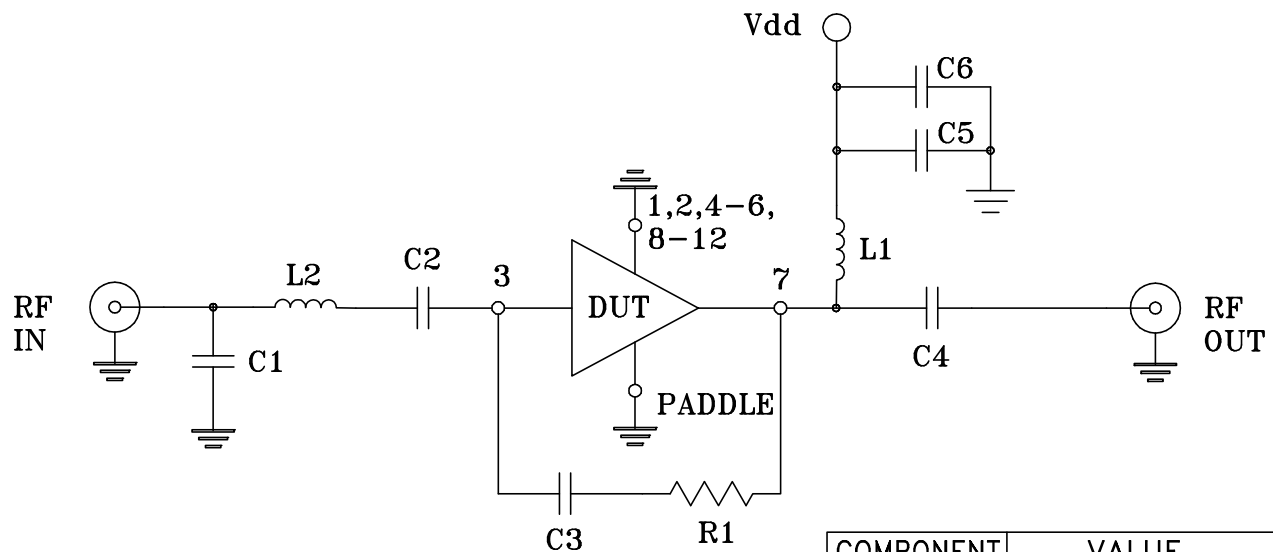
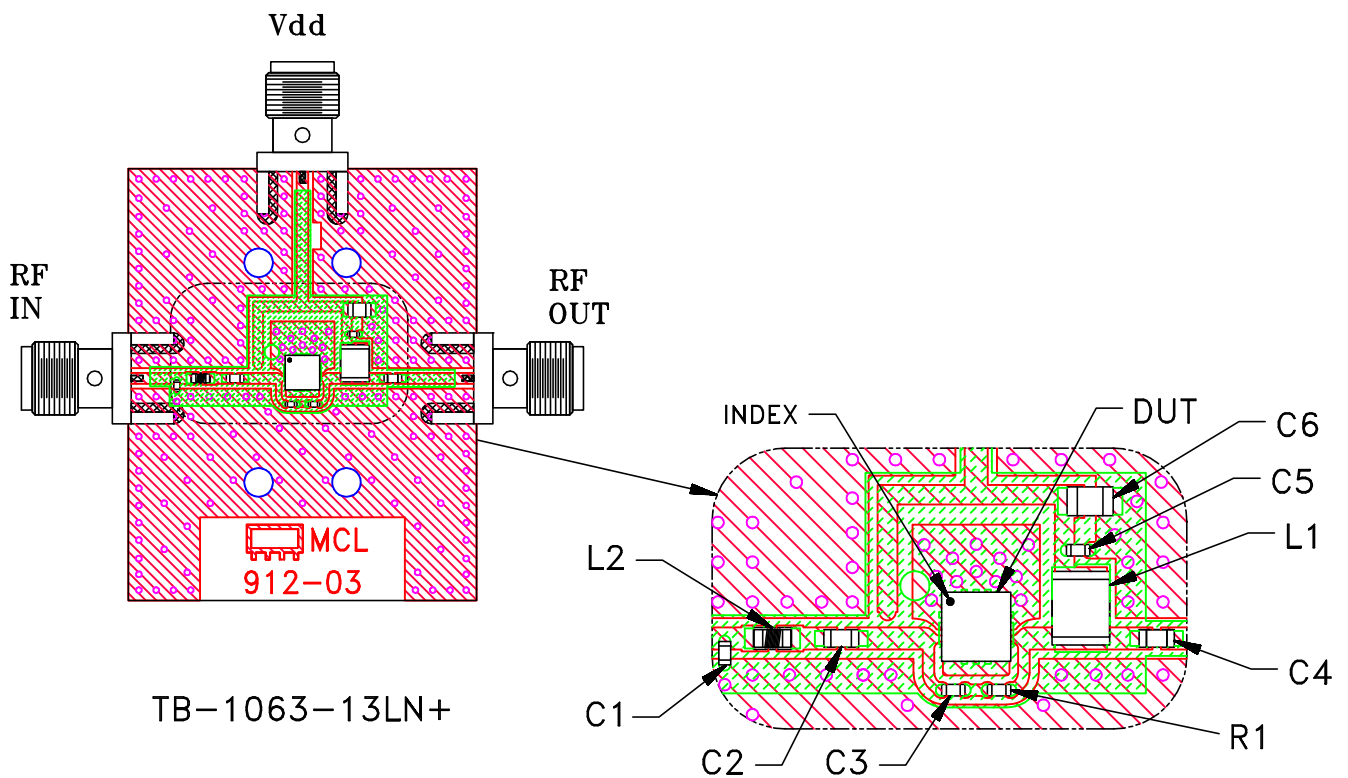

Schematic Diagram

Notes:

1. 50 Ohm SMA Female connectors.
2. PCB Material: R04350 or equivalent,
Dielectric Constant=3.5, Thickness=.020 inch.

COMPONENT	VALUE	SIZE
DUT	LHA-13LN+	3X3 MM
C1	Capacitor 1.5 pF	0402
C2,C4	Capacitor 2.2 uF	0603
C3	Capacitor 0.1 uF	0402
C5	Capacitor 0.001 uF	
C6	Capacitor 10 uF	0805
R1	Resistor 1.5 KOhm	0402
L1	Inductor 15 uH	1210
L2	Inductor 5.1 nH	0603

 **Mini-Circuits®**



All Mini-Circuits products are manufactured under exacting quality assurance and control standards, and are capable of meeting published specifications after being subjected to any or all of the following physical and environmental test.

Specification	Test/Inspection Condition	Reference/Spec
Operating Temperature	-40° to 95° C / 105° C Ambient Environment	Individual Model Data Sheet
Storage Temperature	-55° to 100° C or -65° to 150° Ambient Environment	Individual Model Data Sheet
Thermal Shock	-55° to 100°C, 100 cycles	MIL-STD-202, Method 107, Condition A-3, except +100°C
Mechanical Shock	1.5Kg, 0.5 ms, 5 shock pulses, Y1 direction only	MIL-STD-883, Method 2002, Condition B, except Y1 direction only
Vibration (Variable Frequency)	50g peak	MIL-STD-883, Method 2007, Condition B
Autoclave	15 psig, 100% RH, 121°C, 96 hours	JESD22-A102-C, Condition C
HAST	130°C, 85% RH, 96 hours	JESD22-A110
Solderability	10X Magnification	J-STD-002, Para 4.2.5, Test S, 95% Coverage
Solder Reflow Heat	Sn-Pb Eutetic Process: 240°C peak Pb-Free Process: 260°C peak	J-STD-020C, Table 4-1, 4-2 and 5-2; Figure 5-1
Moisture Sensitivity: Level 1	Bake at 125°C for 24 hours. Soak at 85°C/85%RH for 168 hours Reflow 3 cycles at 260°C peak	J-STD-020
Marking Resistance to Solvents	Isopropyl alcohol + mineral spirits at 25°C; terpene defluxer at 25°C; distilled water + proylene glycol monomethyl ether +	MIL-STD-202, Method 215



All Mini-Circuits products are manufactured under exacting quality assurance and control standards, and are capable of meeting published specifications after being subjected to any or all of the following physical and environmental test.

Specification	Test/Inspection Condition	Reference/Spec
	monoethanolamine at 63°C to 70°C	