



LTCC SURFACE MOUNT

Low Pass Filter

LFHK-2850+

50Ω

DC to 2850 MHz

THE BIG DEAL

- Low Insertion Loss, Typ. 1.5 dB
- Passband Return Loss, Typ. 17 dB
- Stopband Rejection, Typ. 75 dB
- 1008 Surface Mount Footprint
- Power Handling: 7.5 W

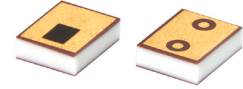

Generic photo used for illustration purposes only

APPLICATIONS

- Harmonic Rejection and Spurious Cleanup
- Radar, EW, and ECM Defense Systems
- Satellite Communications
- Test and Measurement Equipment
- UHF Transmitters / Receivers

FUNCTIONAL DIAGRAM

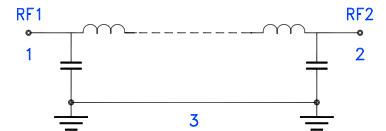

PRODUCT OVERVIEW

Mini-Circuits' LFHK-2850+ is a miniature low temperature co-fired ceramic (LTCC) low pass filter with a DC to 2850 MHz passband supporting a variety of applications. This model provides 1.5 dB typical insertion loss over a wide band due to its rugged monolithic construction. Housed in a small 1008 ceramic form factor the filter is ideal for dense signal chain PCB layouts where it complements MMIC size and performance. The LTCC fabrication process assures minimal RF performance variation while delivering a product that is well suited for environmental extremes of high humidity and temperature.

KEY FEATURES

Features	Advantages
Ultra-Wide Stopband	The LTCC lowpass filter provides a very good stopband rejection up to 50 GHz, suitable for wide band applications.
LTCC Construction	Provides repeatable performance in a rugged, ceramic package well suited for tough environments such as high humidity and temperature extremes.
Small Size, 1008	Saves space in dense circuit board layouts and minimizes the effects of parasitics.
Rugged Power Handling, 7.5 Watts	Handles up to 7.5 Watts in a small 1008 package.



LTCC SURFACE MOUNT

Low Pass Filter

LFHK-2850+

50Ω

DC to 2850 MHz

ELECTRICAL SPECIFICATIONS^{1,2,3} AT +25°C

Parameter	F#	Frequency (MHz)	Min.	Typ.	Max.	Units	
Passband	Insertion Loss	DC-F1	DC - 2850	—	1.5	2.5	dB
	Freq. Cut-Off ⁴	Fc	3100	—	3	—	dB
	Return Loss	DC-F1	DC - 2850	10	17	—	dB
Stopband	Rejection	F2-F3	3800 - 6000	20	31	—	dB
		F3-F4	6000 - 11500	65	75	—	
		F4-F5	11500 - 22000	35	50	—	
		F5-F6	22000 - 40000	20	33	—	
		F6-F7	40000 - 50000	—	29	—	

1. Tested on Evaluation Board P/N TB-LFHK-2850+ with connectors and feedline de-embedded with thru-line compensation.
2. This filter is bi-directional, RF1 and RF2 ports may be interchanged.
3. In applications where DC voltage and/or current is present at either the input or output ports, external DC blocking capacitors are required.
4. Typical variation ±5%.

ABSOLUTE MAXIMUM RATINGS⁵

Parameter	Ratings
Operating Temperature	-55°C to +125°C
Storage Temperature	-55°C to +125°C
Input Power ⁶	7.5 W @ +25°C

5. Permanent damage may occur if any of these limits are exceeded.
6. Power rating applies only to signals within the passband. Power rating above +25°C operating temperature decreases linearly to 1.3 W at +125°C.

TYPICAL FREQUENCY RESPONSE AT +25°C

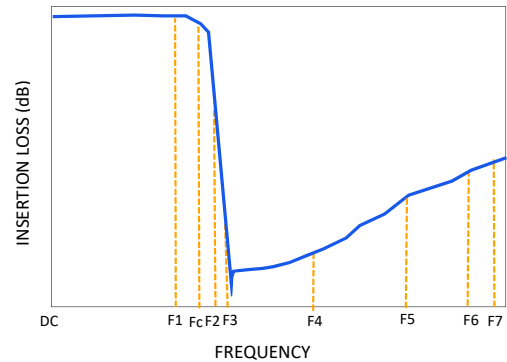



TYPICAL PERFORMANCE GRAPHS

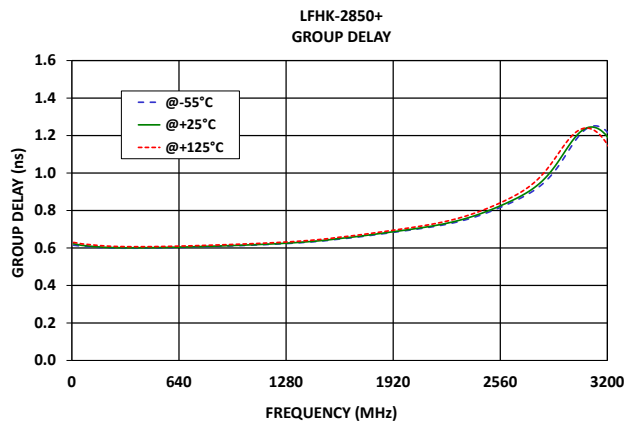
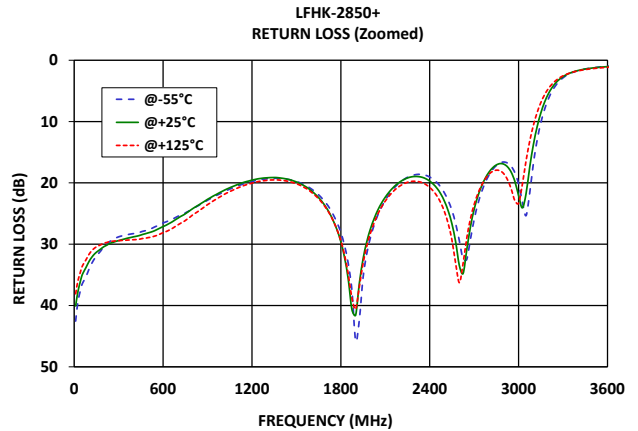
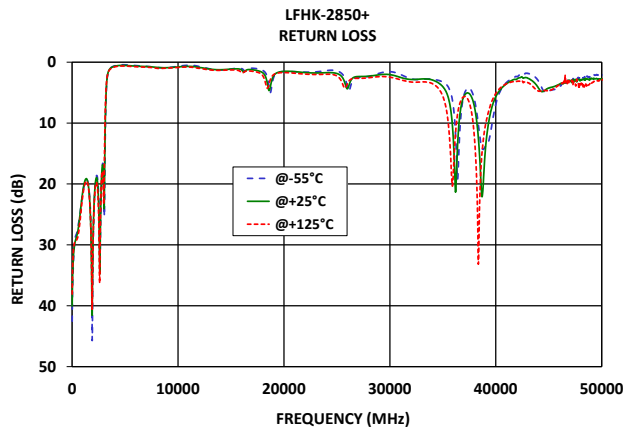
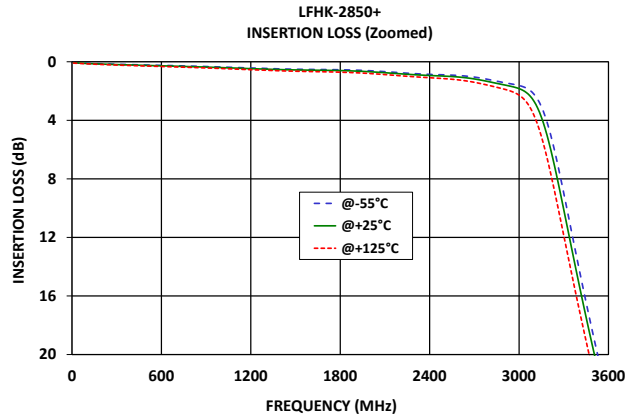
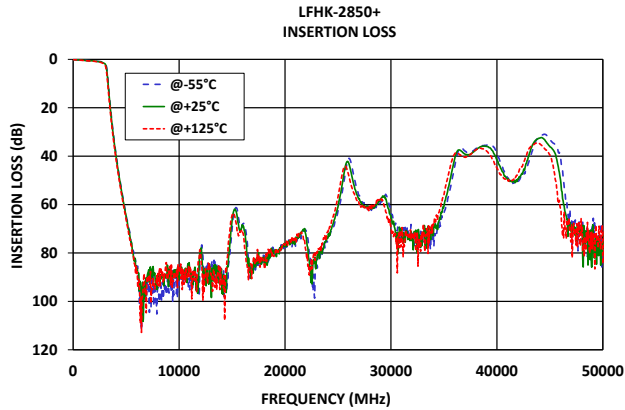



FUNCTIONAL DIAGRAM

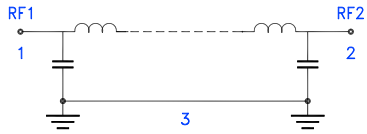
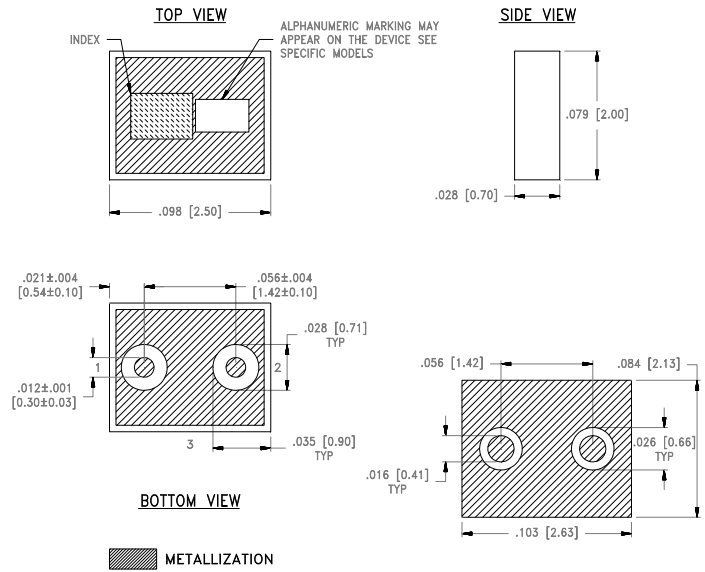

Figure 1. LFHK-2850+ Functional Diagram

PAD DESCRIPTION

Function	Pad Number	Description
RF1 ²	1	Connects to RF Input Port
RF2 ²	2	Connects to RF Output Port
GROUND	3	Connects to Ground on PCB, (See drawing PL-798)
NC	—	No connection, not used internally. See drawing PL-798 for connection to PCB

CASE STYLE DRAWING



Weight: .019 grams.

Dimensions are in inches (mm). Tolerances: 2Pl. ± .01; 3Pl. ± .005

PRODUCT MARKING*: ZX

*Marking may contain other features or characters for internal lot control.



SUGGESTED PCB LAYOUT (PL-798)

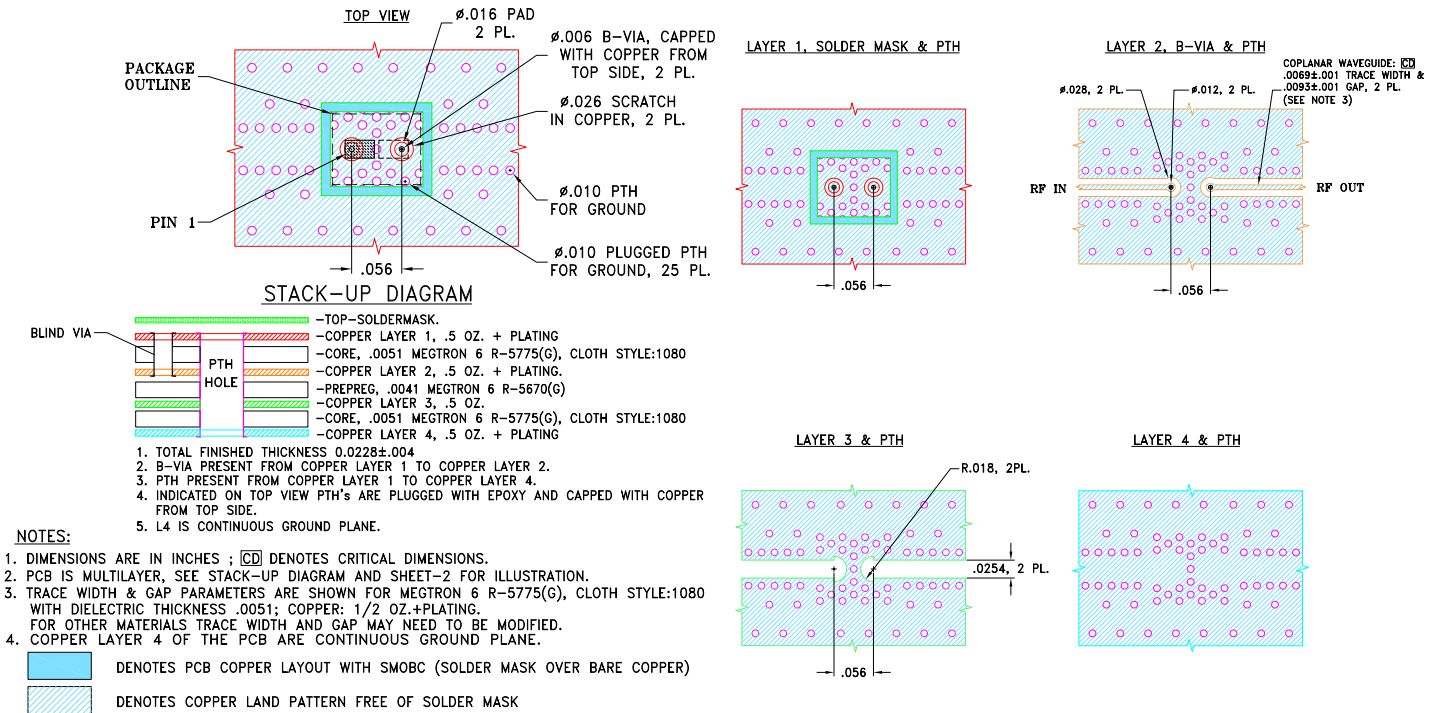

Figure 2. Suggested PCB Layout PL-798



LTCC SURFACE MOUNT

Low Pass Filter

LFHK-2850+

50Ω

DC to 2850 MHz

ADDITIONAL DETAILED INFORMATION IS AVAILABLE ON OUR DASHBOARD.

[CLICK HERE](#)

Performance Data and Graphs	Data Graphs S-Parameter (S2P Files) Data Set (.zip file) De-embedded to device pads
Case Style	NL1008C-9 Lead Finish: Gold over Electroless Nickel
RoHS Status	Compliant
Tape and Reel	TR-F75
Suggested Layout for PCB Design	PL-798
Evaluation Board	TB-LFHK-2850+
	Gerber File
Environmental Rating	ENV06T10

NOTES

- A. Performance and quality attributes and conditions not expressly stated in this specification document are intended to be excluded and do not form a part of this specification document.
- B. Electrical specifications and performance data contained in this specification document are based on Mini-Circuits' applicable established test performance criteria and measurement instructions.
- C. The parts covered by this specification document are subject to Mini-Circuits' standard limited warranty and terms and conditions (collectively, "Standard Terms"); Purchasers of this part are entitled to the rights and benefits contained therein. For a full statement of the standard terms and the exclusive rights and remedies thereunder, please visit Mini-Circuits' website at www.minicircuits.com/terms/viewterm.html



Typical Performance Data

FREQ. (MHz)	INSERTION LOSS			INPUT RETURN LOSS			OUTPUT RETURN LOSS		
	(dB)			(dB)			(dB)		
	@-55°C	@+25°C	@+125°C	@-55°C	@+25°C	@+125°C	@-55°C	@+25°C	@+125°C
10	0.06	0.06	0.09	42.54	40.05	38.09	42.44	40.16	38.11
50	0.08	0.09	0.11	36.78	35.30	33.89	36.69	35.35	33.93
100	0.10	0.12	0.14	34.08	32.82	31.66	33.83	32.81	31.68
200	0.14	0.16	0.19	30.41	30.41	29.82	30.25	30.32	29.82
500	0.22	0.25	0.29	27.59	28.15	28.92	27.46	27.93	28.66
1000	0.36	0.40	0.46	21.59	21.37	22.07	21.52	21.32	21.98
1500	0.51	0.56	0.65	19.79	19.85	20.14	19.60	19.82	20.10
1800	0.55	0.60	0.71	28.09	29.60	29.42	28.18	30.01	30.06
1950	0.59	0.66	0.77	35.46	32.41	33.14	33.84	32.05	32.90
2000	0.61	0.68	0.80	28.90	27.49	28.19	28.08	27.21	27.89
2400	0.86	0.94	1.09	19.05	19.72	20.75	18.74	19.52	20.46
2600	0.94	1.05	1.25	29.46	33.49	36.28	27.10	27.66	27.44
2850	1.33	1.47	1.74	17.16	17.07	17.93	16.59	16.61	17.37
3000	1.62	1.84	2.28	20.19	22.08	23.33	19.13	20.97	21.54
3100	2.22	2.70	3.66	16.77	13.73	10.59	15.99	13.33	10.29
3800	30.90	31.71	33.08	0.75	0.81	0.92	0.71	0.81	0.92
4000	37.69	38.45	39.75	0.61	0.68	0.79	0.59	0.69	0.80
4500	52.03	52.76	53.96	0.45	0.54	0.65	0.44	0.55	0.66
5000	64.17	64.75	66.06	0.43	0.54	0.64	0.41	0.53	0.64
5500	75.90	75.49	76.96	0.49	0.59	0.69	0.45	0.57	0.68
5800	82.66	82.24	84.61	0.53	0.62	0.72	0.48	0.61	0.72
6000	86.26	87.20	88.48	0.56	0.64	0.74	0.51	0.64	0.75
6200	92.08	88.36	90.83	0.59	0.66	0.76	0.55	0.68	0.79
6400	94.09	93.99	97.86	0.61	0.68	0.78	0.59	0.72	0.83
6600	93.41	108.28	95.12	0.63	0.69	0.79	0.64	0.78	0.88
6800	96.96	98.70	96.93	0.66	0.71	0.81	0.69	0.83	0.92
7000	91.66	89.44	89.65	0.69	0.72	0.83	0.73	0.87	0.94
7400	91.25	86.75	94.58	0.75	0.76	0.87	0.79	0.90	0.98
7800	100.47	93.37	92.88	0.82	0.82	0.94	0.82	0.93	1.01
8000	94.22	90.69	88.47	0.86	0.85	1.00	0.83	0.93	1.02
8400	92.67	90.01	87.43	0.91	0.91	1.02	0.81	0.92	1.01
8600	92.85	89.54	91.24	0.93	0.91	1.01	0.80	0.91	1.00
8800	93.52	90.31	83.95	0.92	0.91	0.99	0.78	0.89	0.98
9000	92.70	93.95	87.36	0.89	0.90	0.97	0.75	0.87	0.96
9400	100.34	89.21	91.65	0.83	0.86	0.94	0.69	0.82	0.92
9600	89.71	88.74	88.44	0.77	0.84	0.91	0.65	0.79	0.89
10000	91.73	91.17	85.86	0.68	0.78	0.87	0.59	0.75	0.86
11500	91.71	85.86	87.18	0.55	0.73	0.87	0.58	0.78	0.94
13000	87.09	88.31	89.14	1.10	1.13	1.27	1.00	1.18	1.30
16000	68.05	69.10	71.49	1.05	1.27	1.72	1.23	1.41	1.51
18000	84.22	82.60	83.18	1.34	1.73	2.22	1.05	1.40	1.71
20000	76.58	76.53	76.76	1.54	1.51	1.70	1.75	1.99	2.11
21000	77.60	74.09	74.92	1.57	1.55	1.81	1.58	1.89	2.05
22000	70.85	73.50	79.58	1.64	1.71	1.96	1.43	1.72	1.92
23000	84.32	82.76	79.04	1.59	1.77	2.02	1.34	1.62	1.88
24000	75.44	73.61	71.42	1.39	1.73	1.98	1.29	1.66	1.98
25000	62.67	60.95	56.85	1.42	1.86	2.26	1.56	2.17	2.71
26000	41.03	42.74	47.70	4.10	4.36	3.51	4.13	3.51	2.97
27000	56.21	57.49	59.96	2.51	2.35	2.64	2.29	2.58	2.80
29000	59.39	57.86	57.28	1.82	2.07	2.38	1.60	2.04	2.40
30000	63.05	64.50	69.28	1.56	2.04	2.45	1.46	1.96	2.40
33000	75.48	72.45	73.97	2.81	2.76	3.24	2.61	3.15	3.52
35000	63.59	60.67	56.00	3.28	4.04	5.62	2.81	3.42	4.53
39000	35.51	35.90	37.76	13.88	14.78	10.57	8.10	12.01	27.80
40000	38.77	41.42	44.81	6.88	5.65	5.12	12.30	9.12	6.66
41000	48.98	49.58	49.76	3.36	3.56	3.55	3.04	3.38	3.55
43000	42.59	40.09	37.15	1.84	2.61	3.32	1.97	2.79	3.55
45000	33.18	36.06	39.48	4.72	4.26	4.67	4.03	4.38	5.01
47000	66.45	71.10	75.49	2.81	3.05	3.05	2.32	2.96	3.38
50000	75.11	75.74	84.25	2.07	2.76	2.90	2.21	3.08	3.00

Typical Performance Data

FREQ. (MHz)	GROUP DELAY		
	(nsec)		
	@-55°C	@+25°C	@+125°C
10	0.62	0.62	0.63
20	0.61	0.62	0.63
30	0.61	0.62	0.63
40	0.61	0.62	0.63
50	0.61	0.62	0.62
100	0.61	0.61	0.62
200	0.60	0.60	0.61
220	0.60	0.60	0.61
240	0.60	0.60	0.61
260	0.60	0.60	0.61
280	0.60	0.60	0.61
300	0.60	0.60	0.61
400	0.60	0.60	0.61
500	0.60	0.60	0.61
600	0.60	0.60	0.61
700	0.60	0.61	0.61
800	0.61	0.61	0.61
900	0.61	0.61	0.62
1000	0.61	0.61	0.62
1100	0.62	0.62	0.62
1200	0.62	0.62	0.63
1300	0.62	0.63	0.63
1400	0.63	0.63	0.64
1500	0.64	0.64	0.65
1600	0.65	0.65	0.66
1700	0.66	0.66	0.67
1800	0.67	0.67	0.68
1900	0.68	0.68	0.69
2000	0.69	0.70	0.71
2100	0.71	0.71	0.72
2200	0.72	0.72	0.74
2300	0.74	0.74	0.76
2400	0.76	0.77	0.78
2600	0.83	0.84	0.86
2800	0.93	0.95	0.98
2850	0.97	0.99	1.03

Typical Performance Curves

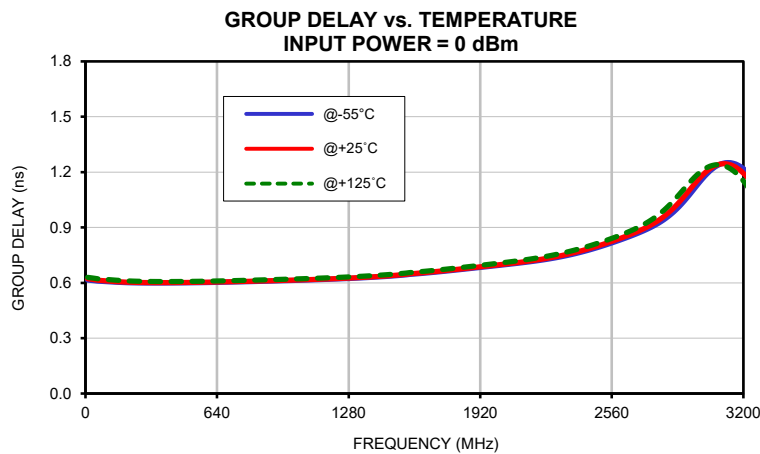
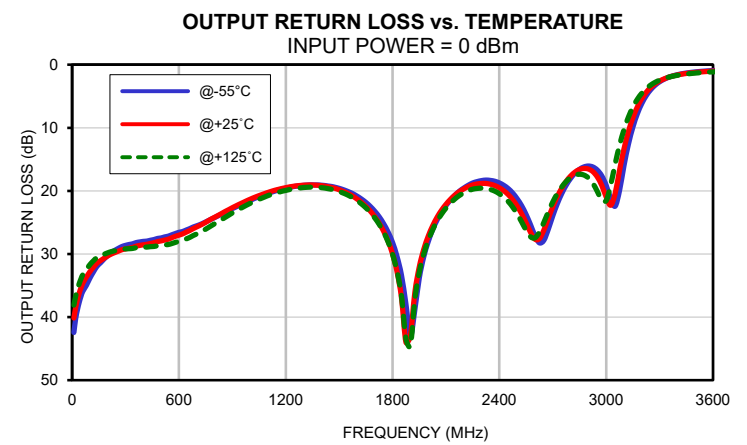
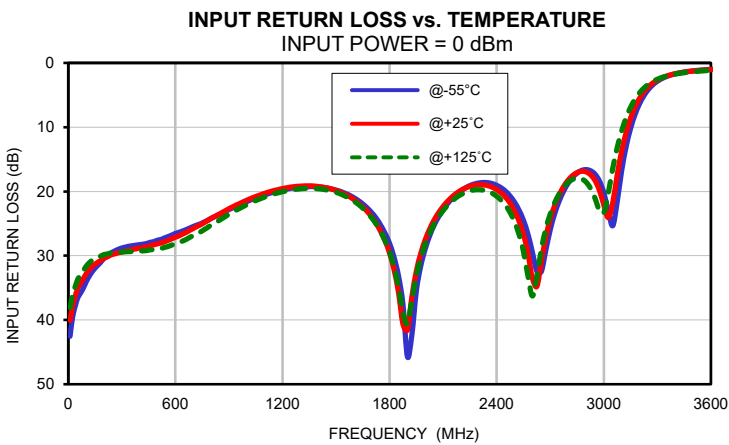
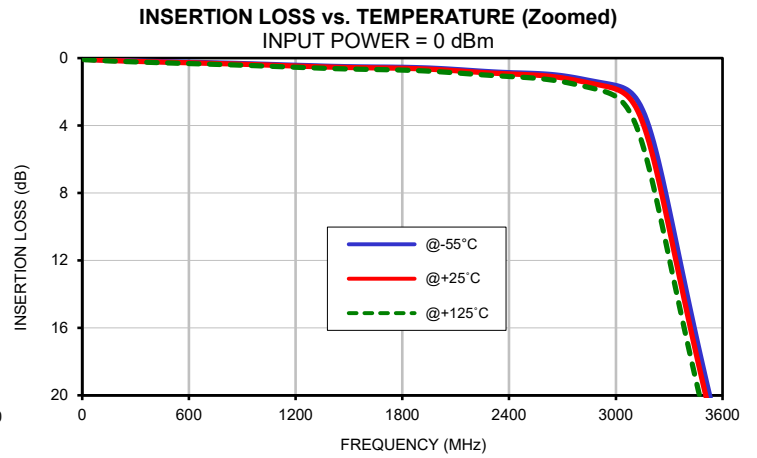
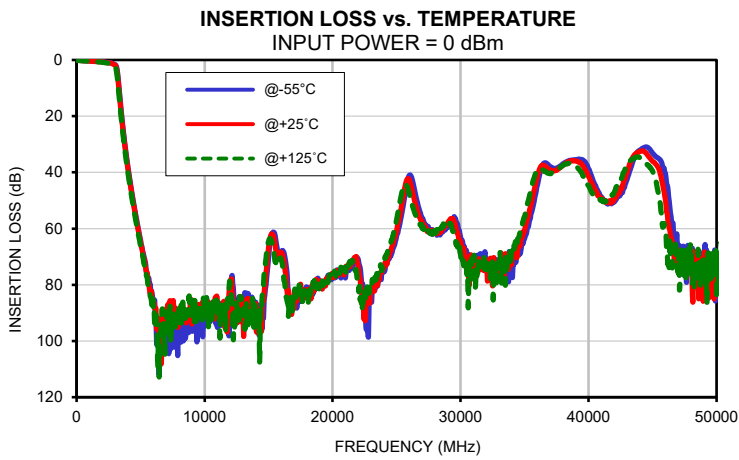

Case Style

NL

Outline Dimensions

NL1008C-9

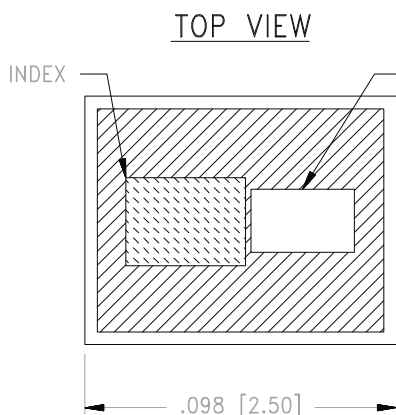

ALPHANUMERIC MARKING MAY APPEAR ON THE DEVICE SEE SPECIFIC MODELS

SIDE VIEW

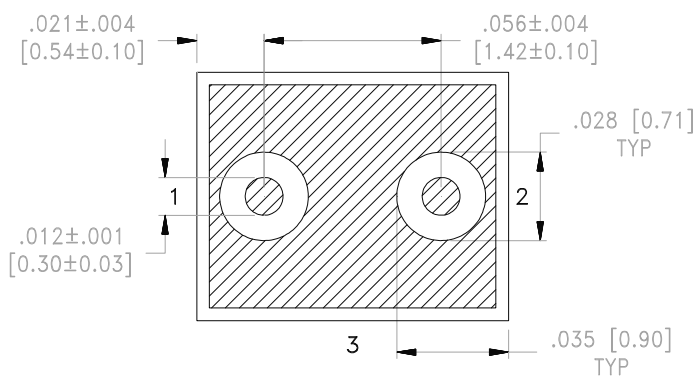
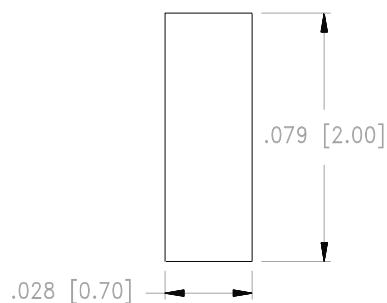

BOTTOM VIEW

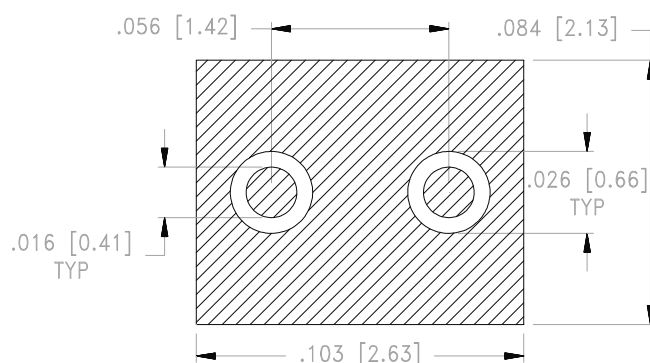

 METALLIZATION

SUGGESTED LAYOUT FOR PCB LAND PATTERN
PATTERN TO BE WITHIN ±.002

Dimensions are in inches (mm). Tolerances: 2Pl. ± .01; 3Pl. ± .005

Notes:

1. Open style, Ceramic base.
2. Termination finish: **as shown below or indicated on Data sheet.**
For RoHS Case Styles: Gold plate over nickel plate. All models, (+) suffix.
3. Weight: .019 grams.
4. Pad tolerance is non-cumulative.

 **Mini-Circuits**[®]
ISO 9001 ISO 14001 CERTIFIED

ALL NEW
 minicircuits.com

P.O. Box 350166, Brooklyn, New York 11235-0003 (718) 934-4500 Fax (718) 332-4661 For detailed performance specs & shopping online see Mini-Circuits web site



The Design Engineers Search Engine Provides ACTUAL Data Instantly From MINI-CIRCUITS At: www.minicircuits.com

RF/IF MICROWAVE COMPONENTS

THIRD ANGLE PROJECTION

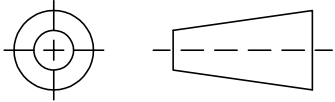

REVISIONS

REV OR	ECN No.	DESCRIPTION	DATE	DR	AUTH
	ECO-023057	NEW RELEASE	SEP 24	AGS	GT

SUGGESTED MOUNTING CONFIGURATION FOR NL1008C-9 CASE STYLE

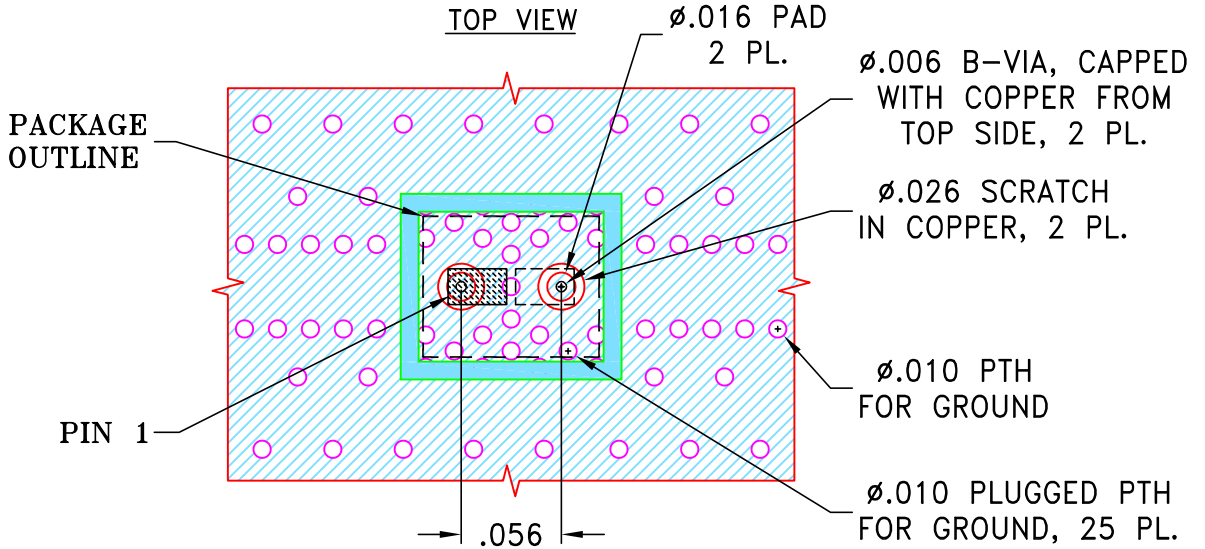

STACK-UP DIAGRAM

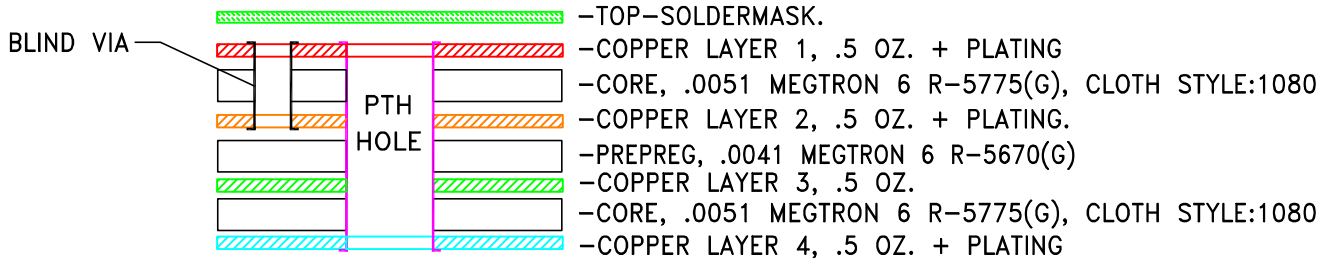

1. TOTAL FINISHED THICKNESS 0.0228±.004 .
2. B-VIA PRESENT FROM COPPER LAYER 1 TO COPPER LAYER 2.
3. PTH PRESENT FROM COPPER LAYER 1 TO COPPER LAYER 4.
4. INDICATED ON TOP VIEW PTH'S ARE PLUGGED WITH EPOXY AND CAPPED WITH COPPER FROM TOP SIDE.
5. L4 IS CONTINUOUS GROUND PLANE.

NOTES:

1. PCB IS MULTILAYER, SEE STACK-UP DIAGRAM AND SHEET-2 FOR ILLUSTRATION.
2. TRACE WIDTH & GAP PARAMETERS ARE SHOWN FOR MEGTRON6 R-5775(G), CLOTH STYLE:1080 WITH DIELECTRIC THICKNESS .0051; COPPER: 1/2 OZ.+PLATING.
FOR OTHER MATERIALS TRACE WIDTH AND GAP MAY NEED TO BE MODIFIED.
3. COPPER LAYER 4 OF THE PCB ARE CONTINUOUS GROUND PLANE.



DENOTES PCB COPPER LAYOUT WITH SMOBC (SOLDER MASK OVER BARE COPPER)

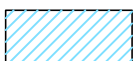

DENOTES COPPER LAND PATTERN FREE OF SOLDER MASK

UNLESS OTHERWISE SPECIFIED	INITIALS	DATE
DIMENSIONS ARE IN INCHES	DRAWN AGS	14 SEP 24
TOLERANCES ON:	CHECKED MD	16 SEP 24
2 PL DECIMALS ±	APPROVED GTP	17 SEP 24
3 PL DECIMALS ± .002		
ANGLES ±		
FRACTIONS ±		



Mini-Circuits®

13 Neptune Avenue
Brooklyn NY 11235

PL, NL1008C-9, TB-LFHK-XXXX+

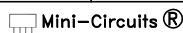

THIS DOCUMENT AND ITS CONTENTS ARE THE PROPERTY OF MINI-CIRCUITS. EXCEPT FOR USE EXPRESSLY GRANTED, IN WRITING, TO ITS VENDORS, VENDEE AND THE UNITED STATES GOVERNMENT, MINI-CIRCUITS RESERVES ALL PROPRIETARY DESIGN, USE, MANUFACTURING AND REPRODUCTION RIGHTS THERETO. THESE CONTENTS SHALL NOT BE USED, DUPLICATED OR DISCLOSED TO ANY OUTSIDE PARTY, IN WHOLE OR IN PART, WITHOUT WRITTEN PERMISSION OF MINI-CIRCUITS.

SIZE	CODE IDENT	DRAWING NO:	REV:
A	15542	98-PL-798	OR
FILE:	98-PL-798	SCALE:	9:1
		SHEET:	1 OF 2

LAYER 1, SOLDER MASK & PTH

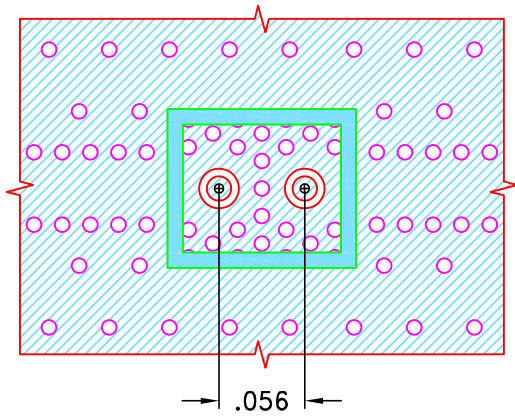

LAYER 2, B-VIA & PTH

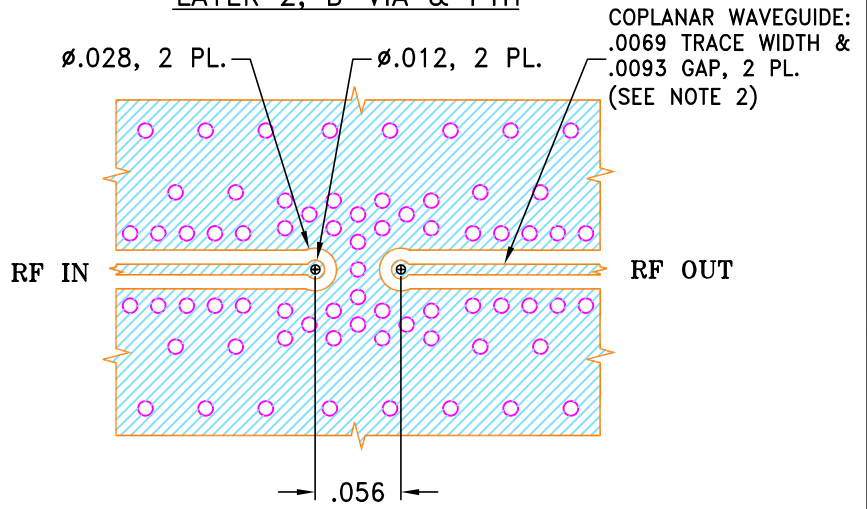

LAYER 3 & PTH

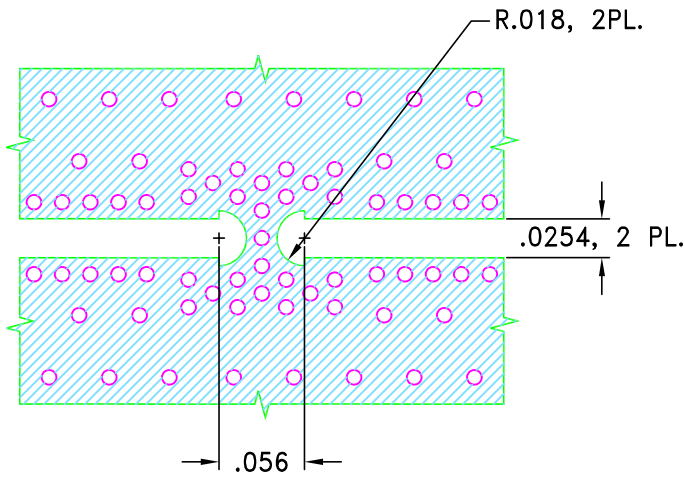

LAYER 4 & PTH

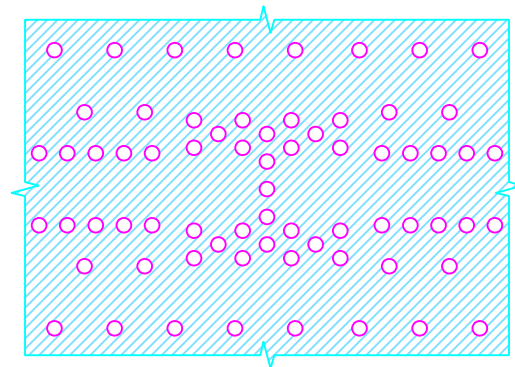

Mini-Circuits

THIS DOCUMENT AND ITS CONTENTS ARE THE PROPERTY OF MINI-CIRCUITS. EXCEPT FOR USE EXPRESSLY GRANTED, IN WRITING, TO ITS VENDORS, VENDEE AND THE UNITED STATES GOVERNMENT, MINI-CIRCUITS RESERVES ALL PROPRIETARY DESIGN, USE, MANUFACTURING AND REPRODUCTION RIGHTS THERETO. THESE CONTENTS SHALL NOT BE USED, DUPLICATED OR DISCLOSED TO ANY OUTSIDE PARTY, IN WHOLE OR IN PART, WITHOUT WRITTEN PERMISSION OF MINI-CIRCUITS.

ALL DIMENSIONS ARE IN INCHES EXCEPT OTHERWISE SPECIFIED

SIZE A	CODE IDENT 15542	DRAWING NO: 98-PL-798	REV: OR
-----------	---------------------	--------------------------	------------

Evaluation Board and Circuit

TB-LFHK-2850+

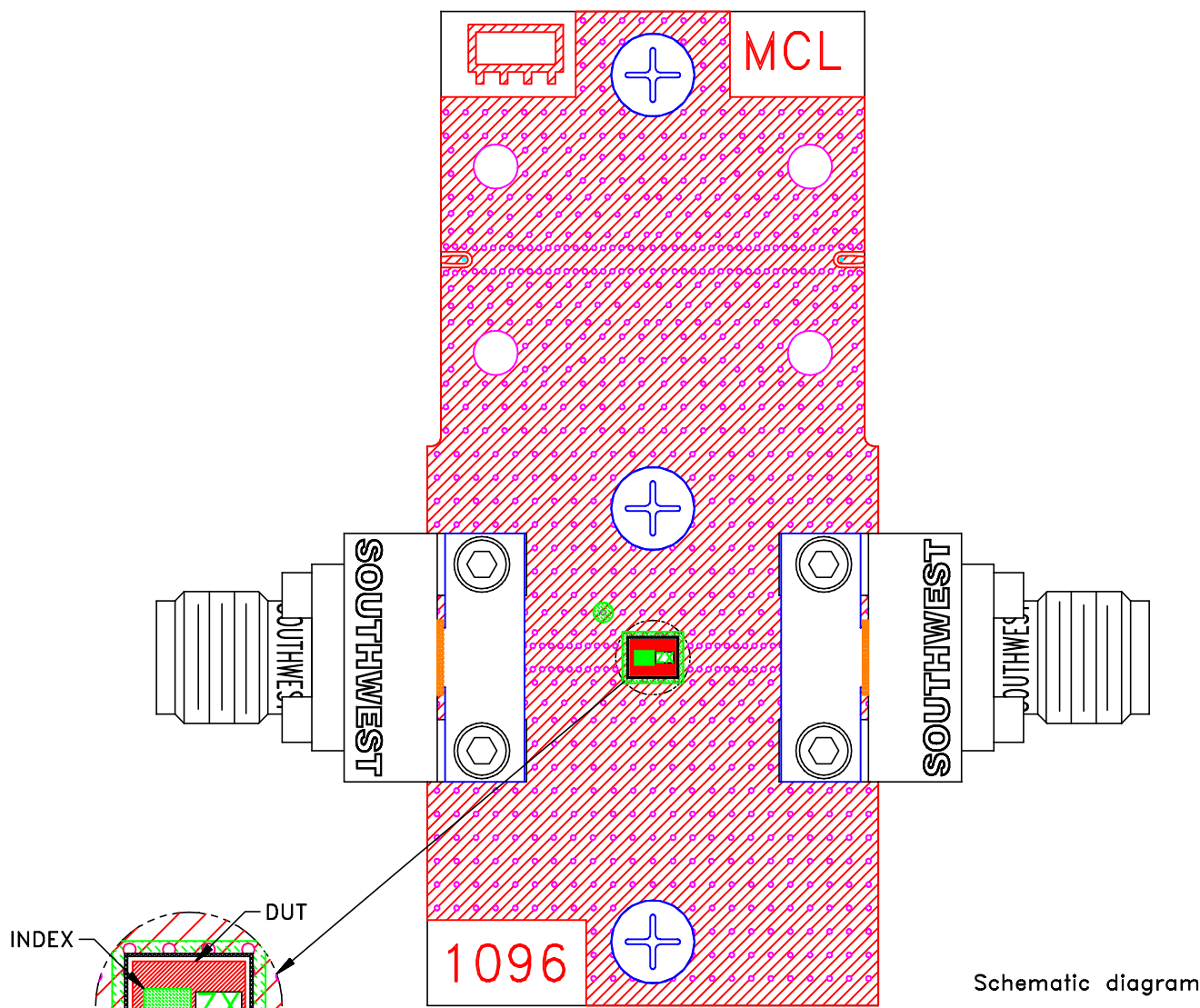

Schematic diagram

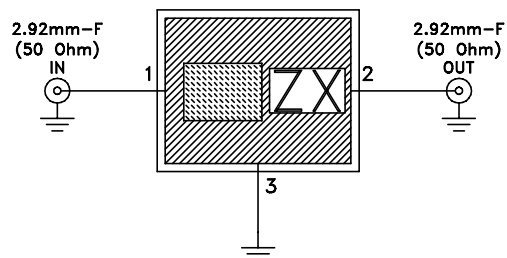

STACK-UP DIAGRAM

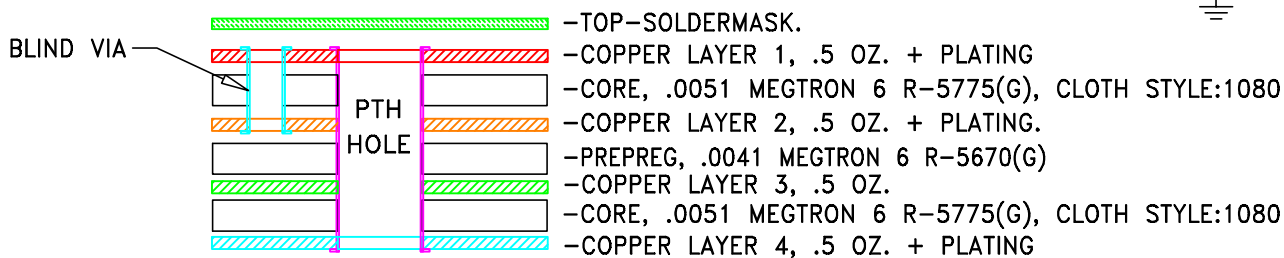

Notes:

1. PCB Material: MEGTRON-6 R5775(G) OR Equivalent, Dielectric Constant=3.6
2. Total finished thickness: .023
3. 50 Ohm 2.92mm Female End Launch Connector.

 **Mini-Circuits®**

All Mini-Circuits products are manufactured under exacting quality assurance and control standards, and are capable of meeting published specifications after being subjected to any or all of the following physical and environmental test.

Specification	Test/Inspection Condition	Reference/Spec
Operating Temperature	-55° to 125° C Ambient Environment	Individual Model Data Sheet
Storage Temperature	-55° to 125° C Ambient Environment	Individual Model Data Sheet
Humidity	90 to 95% RH, 240 hours, 50°C	MIL-STD-202, Method 103, Condition A, Except 50°C and end-point electrical test done within 12 hours
Solder Reflow Heat	Sn-Pb Eutectic Process 225°C peak Pb-Free Process 245° - 250°C peak	J-STD-020C, Table 4-1, 4-2 and 5-2, Figure 5-1
Solderability	10X Magnification	J-STD-002, Test B,B1, 95% Coverage
Thermal Shock	-55° to +125°C, 15 min dwell,250 cycles	MIL-STD-202, Method 107
Bend Test	1mm, deflection for 5 seconds Span of bending: 2.75"	--
High Temp Storage	125°C to 1000 Hrs	---