



CERAMIC

Low Pass Filter

LFCW-1292+

Mini-Circuits

50Ω DC to 12900 MHz

THE BIG DEAL

- Low loss, 1.3 dB typ.
- Good rejection 45 dB typ.
- Small size 0603 (0.063" x 0.032" x 0.024")

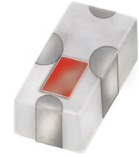

Generic photo used for illustration purposes only

CASE STYLE: JC0603C-1

+RoHS Compliant

The +Suffix identifies RoHS Compliance. See our web site for RoHS Compliance methodologies and qualifications

APPLICATIONS

- Test & Measurement
- 5G MIMO
- EW, Radar and ECM Defense Systems
- Satellite Communications

PRODUCT OVERVIEW

Mini-Circuits' LFCW-1292+ is an LTCC low pass filter with a passband from DC to 12900 MHz, supporting a variety of applications. This model provides 1.3 dB typ. passband insertion loss and provides a very good stopband rejection due to strategically constructed layout with minimal interaction between components. It handles up to 2.5W RF input power and provides a wide operating temperature range from -55 to +125°C. Housed in a small 0603 ceramic form factor, the filter is ideal for dense PCB layouts and with minimal performance variation due to parasitics.

KEY FEATURES

| Feature | Advantages |
|--|---|
| Ultra-wide stopband | The LTCC lowpass filter provides a very good stopband rejection until 26.5 GHz suitable for high end applications. |
| LTCC Construction | Provides repeatable performance in a rugged, ceramic package well suited for tough environments such as high humidity and temperature extremes. |
| Small size (0.063" x 0.032" x 0.024") | Saves space in dense circuit board layouts and minimizes the effects of parasitics. |
| Good power handling, 2.5W | Supports a wide range of system power requirements. |

REV. OR
ECO-014772
LFCW-1292+
EDU4325
URJ
220830





CERAMIC

Low Pass Filter

LFCW-1292+

ELECTRICAL SPECIFICATIONS^{1,2} AT 25°C

| Parameter | F# | Frequency (MHz) | Min. | Typ. | Max. | Units | |
|-----------|----------------|-----------------|---------------|------|------|-------|----|
| Passband | Insertion Loss | DC-F1 | DC - 12900 | — | 1.3 | 2.2 | dB |
| | Freq. Cut-Off | F2* | 13900 | — | 3 | — | dB |
| | Return Loss | DC-F1 | DC - 12900 | — | 13 | — | dB |
| Stop Band | Rejection Loss | F3-F4 | 17000 - 19500 | 20 | 45 | — | dB |
| | | F4-F5 | 19500 - 22900 | 25 | 36 | — | dB |
| | | F5-F6 | 22900 - 25000 | 20 | 33 | — | dB |
| | | F6-F7 | 25000 - 26500 | — | 25 | — | dB |

¹ DC de-coupling capacitors are required in Applications where DC voltage and/or current is present at either input or output ports. Please contact Mini-Circuits for alternatives if DC pass from IN-OUT is required.

² Measured on Mini-Circuits Characterization Test Board TB-LFCW-1292+

* Typically, a ±5% frequency deviation from the stated value may occur on a unit-to-unit basis.

MAXIMUM RATINGS

| Parameter | Ratings |
|-----------------------|----------------|
| Operating temperature | -55°C to 125°C |
| Storage temperature | -55°C to 125°C |
| RF Power Input* | 2.5W @25°C |

*Passband rating, derate linearly to 0.7W at 125°C ambient
Permanent damage may occur if any of these limits are exceeded.

TYPICAL FREQUENCY RESPONSE

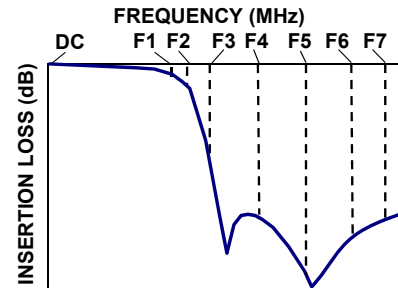

FUNCTIONAL SCHEMATIC

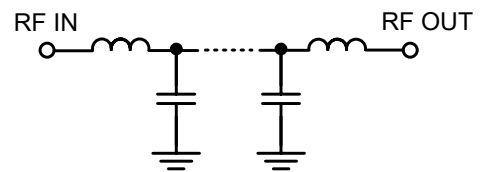



CERAMIC

Low Pass Filter

LFCW-1292+

PAD CONNECTIONS

| | |
|--------|------|
| INPUT | 1 |
| OUTPUT | 3 |
| GROUND | 2, 4 |

PRODUCT MARKING: 9

DEMO BOARD MCL P/N: TB-LFCW-1292+ SUGGESTED PCB LAYOUT (PL-661)

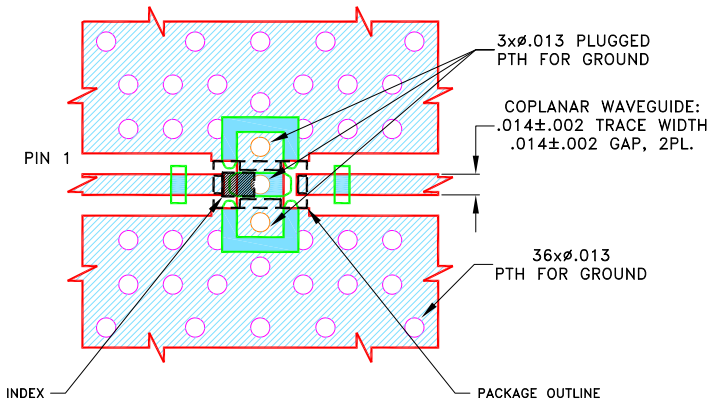

NOTES:

1. COPLANAR WAVEGUIDE PARAMETERS ARE SHOWN FOR ROGERS (R04350B) WITH DIELECTRIC THICKNESS .0066±.0007. COPPER: 1/2 Oz. EACH SIDE. FOR OTHER MATERIALS TRACE WIDTH AND GAP MAY NEED TO BE MODIFIED.
 2. BOTTOM SIDE OF THE PCB IS CONTINUOUS GROUND PLANE.
- DENOTES PCB COPPER PATTERN WITH SMOBC (SOLDER MASK OVER BARE COPPER)
 DENOTES PCB COPPER PATTERN FREE OF SOLDERMASK

OUTLINE DRAWING

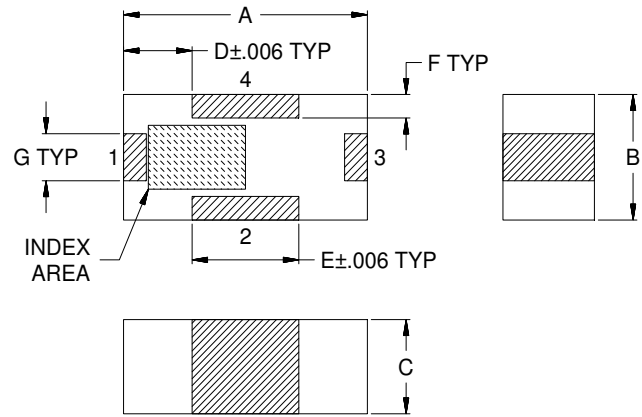

OUTLINE DIMENSIONS (Inches) mm

| A | B | C | D | E | F | G | Wt. |
|------|------|------|------|------|------|------|-------|
| .063 | .032 | .024 | .018 | .028 | .006 | .012 | grams |
| 1.60 | 0.80 | 0.60 | 0.45 | 0.70 | 0.15 | 0.30 | .005 |

Note: Please refer to case style drawing for details



CERAMIC

Low Pass Filter

LFCW-1292+

TYPICAL PERFORMANCE DATA AT 25°C

| Frequency (MHz) | Insertion Loss (dB) | Return Loss (dB) |
|-----------------|---------------------|------------------|
| 10 | 0.08 | 48.69 |
| 100 | 0.10 | 44.02 |
| 2000 | 0.19 | 31.50 |
| 5000 | 0.41 | 14.42 |
| 10000 | 0.62 | 16.01 |
| 12900 | 1.12 | 21.92 |
| 13900 | 2.18 | 12.80 |
| 14200 | 3.23 | 8.13 |
| 15550 | 20.34 | 1.09 |
| 16000 | 31.38 | 0.90 |
| 17000 | 41.50 | 0.70 |
| 19500 | 43.56 | 0.29 |
| 22900 | 37.82 | 0.13 |
| 25000 | 34.67 | 0.25 |
| 26500 | 34.84 | 0.30 |

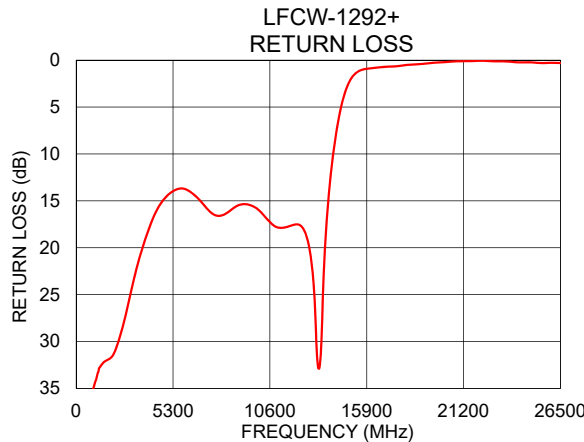
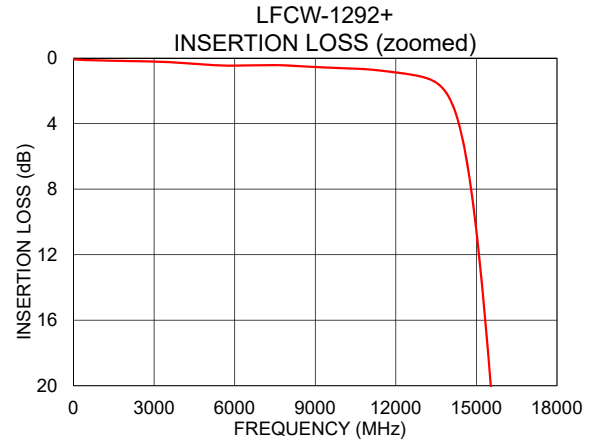
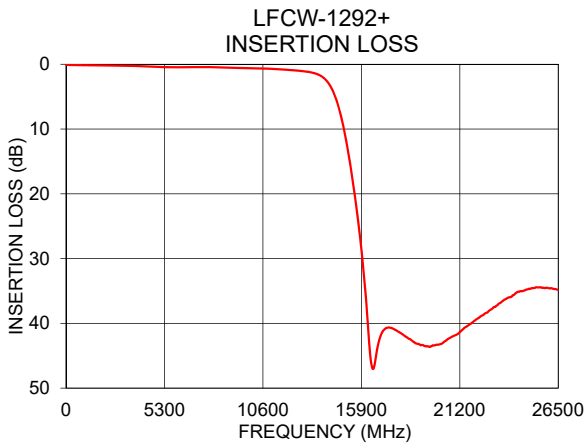

- NOTES**
- A. Performance and quality attributes and conditions not expressly stated in this specification document are intended to be excluded and do not form a part of this specification document.
 - B. Electrical specifications and performance data contained in this specification document are based on Mini-Circuit's applicable established test performance criteria and measurement instructions.
 - C. The parts covered by this specification document are subject to Mini-Circuits standard limited warranty and terms and conditions (collectively, "Standard Terms"); Purchasers of this part are entitled to the rights and benefits contained therein. For a full statement of the standard. Terms and the exclusive rights and remedies thereunder, please visit Mini-Circuits' website at www.minicircuits.com/MCLStore/terms.jsp



Typical Performance Data

| FREQ. (MHz) | INSERTION LOSS | | | INPUT RETURN LOSS | | | OUTPUT RETURN LOSS | | |
|--------------------|----------------|--------|---------|-------------------|--------|---------|--------------------|--------|---------|
| | (dB) | | | (dB) | | | (dB) | | |
| | @-55°C | @+25°C | @+125°C | @-55°C | @+25°C | @+125°C | @-55°C | @+25°C | @+125°C |
| 10 | 0.06 | 0.08 | 0.09 | 49.51 | 48.69 | 45.56 | 55.55 | 48.69 | 46.69 |
| 50 | 0.06 | 0.09 | 0.09 | 49.97 | 46.22 | 45.30 | 54.48 | 46.08 | 45.14 |
| 100 | 0.07 | 0.10 | 0.10 | 47.98 | 44.02 | 42.47 | 45.99 | 43.63 | 42.49 |
| 500 | 0.07 | 0.13 | 0.14 | 39.97 | 38.31 | 37.35 | 36.22 | 35.76 | 34.22 |
| 1000 | 0.07 | 0.15 | 0.17 | 35.11 | 34.59 | 33.50 | 31.67 | 30.23 | 30.06 |
| 1200 | 0.08 | 0.16 | 0.18 | 33.65 | 33.28 | 32.56 | 30.00 | 29.04 | 28.80 |
| 1400 | 0.08 | 0.16 | 0.19 | 33.13 | 32.46 | 32.11 | 28.93 | 28.29 | 27.82 |
| 1600 | 0.09 | 0.17 | 0.20 | 32.80 | 32.09 | 31.95 | 28.05 | 27.68 | 27.11 |
| 1800 | 0.09 | 0.18 | 0.21 | 32.42 | 31.87 | 31.77 | 27.57 | 27.20 | 26.69 |
| 2000 | 0.09 | 0.19 | 0.21 | 31.78 | 31.50 | 31.45 | 27.23 | 26.80 | 26.41 |
| 2200 | 0.09 | 0.19 | 0.22 | 30.57 | 30.65 | 30.54 | 27.00 | 26.44 | 26.22 |
| 2400 | 0.10 | 0.20 | 0.23 | 29.13 | 29.43 | 29.29 | 26.83 | 26.11 | 26.08 |
| 2600 | 0.10 | 0.20 | 0.24 | 27.72 | 28.03 | 28.15 | 26.33 | 25.62 | 25.74 |
| 2800 | 0.10 | 0.21 | 0.24 | 26.11 | 26.42 | 26.86 | 25.23 | 24.81 | 24.92 |
| 3000 | 0.10 | 0.22 | 0.25 | 24.38 | 24.69 | 25.31 | 23.80 | 23.68 | 23.76 |
| 3500 | 0.13 | 0.25 | 0.29 | 20.57 | 20.82 | 21.46 | 20.52 | 20.53 | 20.86 |
| 4000 | 0.17 | 0.30 | 0.34 | 17.48 | 17.88 | 18.40 | 17.62 | 17.76 | 18.22 |
| 4500 | 0.22 | 0.36 | 0.40 | 15.22 | 15.68 | 16.20 | 15.22 | 15.61 | 15.98 |
| 5000 | 0.27 | 0.41 | 0.45 | 13.99 | 14.42 | 14.95 | 14.03 | 14.37 | 14.86 |
| 5500 | 0.31 | 0.46 | 0.50 | 13.33 | 13.78 | 14.30 | 13.38 | 13.76 | 14.24 |
| 6000 | 0.31 | 0.46 | 0.51 | 13.42 | 13.78 | 14.32 | 13.45 | 13.82 | 14.32 |
| 6500 | 0.29 | 0.45 | 0.52 | 14.06 | 14.43 | 14.79 | 14.31 | 14.70 | 15.09 |
| 7000 | 0.26 | 0.44 | 0.52 | 15.12 | 15.47 | 15.62 | 15.51 | 15.95 | 16.17 |
| 7500 | 0.24 | 0.43 | 0.52 | 16.13 | 16.43 | 16.33 | 17.01 | 17.42 | 17.53 |
| 8000 | 0.25 | 0.46 | 0.55 | 16.32 | 16.54 | 16.46 | 17.72 | 17.95 | 18.28 |
| 10000 | 0.37 | 0.62 | 0.74 | 15.63 | 16.01 | 16.03 | 17.13 | 17.78 | 18.08 |
| 12000 | 0.56 | 0.88 | 1.06 | 17.80 | 17.52 | 18.34 | 19.78 | 19.45 | 20.60 |
| 12900 | 0.75 | 1.12 | 1.38 | 20.61 | 21.92 | 25.15 | 20.95 | 22.04 | 22.80 |
| 13900 | 1.54 | 2.18 | 2.86 | 14.42 | 12.80 | 10.92 | 14.55 | 13.51 | 12.02 |
| 14200 | 2.35 | 3.23 | 4.23 | 9.18 | 8.13 | 6.95 | 10.34 | 9.58 | 8.62 |
| 15000 | 8.61 | 10.59 | 12.94 | 2.12 | 2.12 | 2.02 | 3.80 | 3.87 | 3.83 |
| 15550 | 17.71 | 20.34 | 23.56 | 0.81 | 1.09 | 1.23 | 1.95 | 2.27 | 2.43 |
| 16000 | 27.98 | 31.38 | 35.80 | 0.58 | 0.90 | 1.07 | 1.28 | 1.60 | 1.78 |
| 17000 | 41.94 | 41.50 | 41.44 | 0.38 | 0.70 | 0.83 | 0.61 | 0.89 | 1.05 |
| 17200 | 40.74 | 40.78 | 41.15 | 0.37 | 0.69 | 0.80 | 0.51 | 0.81 | 0.95 |
| 17400 | 40.32 | 40.65 | 41.14 | 0.36 | 0.67 | 0.78 | 0.42 | 0.73 | 0.85 |
| 17600 | 40.33 | 40.81 | 41.34 | 0.32 | 0.64 | 0.74 | 0.34 | 0.66 | 0.76 |
| 17800 | 40.59 | 41.12 | 41.69 | 0.26 | 0.59 | 0.67 | 0.28 | 0.60 | 0.71 |
| 18000 | 40.90 | 41.49 | 42.06 | 0.20 | 0.53 | 0.61 | 0.24 | 0.55 | 0.66 |
| 18200 | 41.33 | 41.89 | 42.40 | 0.16 | 0.50 | 0.57 | 0.20 | 0.51 | 0.61 |
| 18400 | 41.80 | 42.28 | 42.71 | 0.14 | 0.48 | 0.55 | 0.15 | 0.47 | 0.56 |
| 18600 | 42.18 | 42.63 | 42.95 | 0.12 | 0.45 | 0.52 | 0.11 | 0.44 | 0.51 |
| 18800 | 42.50 | 43.04 | 43.09 | 0.09 | 0.42 | 0.49 | 0.07 | 0.41 | 0.47 |
| 19000 | 42.82 | 43.22 | 43.21 | 0.06 | 0.39 | 0.45 | 0.05 | 0.38 | 0.45 |
| 19200 | 43.02 | 43.34 | 43.15 | 0.02 | 0.35 | 0.42 | 0.04 | 0.36 | 0.45 |
| 19500 | 43.26 | 43.56 | 43.10 | 0.04 | 0.29 | 0.36 | 0.02 | 0.33 | 0.44 |
| 20000 | 43.24 | 43.31 | 42.73 | 0.10 | 0.23 | 0.31 | 0.04 | 0.28 | 0.40 |
| 20500 | 42.70 | 42.57 | 42.00 | 0.15 | 0.17 | 0.26 | 0.05 | 0.27 | 0.43 |
| 21000 | 42.06 | 41.78 | 41.17 | 0.20 | 0.11 | 0.23 | 0.03 | 0.28 | 0.49 |
| 21500 | 40.92 | 40.61 | 40.17 | 0.21 | 0.11 | 0.25 | 0.06 | 0.29 | 0.52 |
| 22000 | 39.81 | 39.60 | 39.17 | 0.25 | 0.07 | 0.23 | 0.06 | 0.32 | 0.57 |
| 22500 | 38.74 | 38.60 | 38.18 | 0.26 | 0.09 | 0.28 | 0.04 | 0.37 | 0.60 |
| 22900 | 37.93 | 37.82 | 37.38 | 0.24 | 0.13 | 0.31 | 0.05 | 0.38 | 0.58 |
| 23500 | 36.62 | 36.58 | 36.09 | 0.26 | 0.13 | 0.30 | 0.00 | 0.40 | 0.58 |
| 24000 | 35.63 | 35.85 | 35.51 | 0.18 | 0.21 | 0.35 | 0.01 | 0.39 | 0.53 |
| 24500 | 34.87 | 35.03 | 35.15 | 0.15 | 0.24 | 0.34 | 0.02 | 0.37 | 0.52 |
| 25000 | 34.40 | 34.67 | 34.87 | 0.13 | 0.25 | 0.35 | 0.03 | 0.36 | 0.54 |
| 25500 | 34.10 | 34.46 | 34.62 | 0.05 | 0.31 | 0.41 | 0.04 | 0.31 | 0.50 |
| 26000 | 33.83 | 34.58 | 34.35 | 0.07 | 0.29 | 0.40 | 0.07 | 0.28 | 0.51 |
| 26500 | 33.71 | 34.84 | 34.36 | 0.07 | 0.30 | 0.44 | 0.10 | 0.27 | 0.51 |

Typical Performance Data

| FREQ. (MHz) | GROUP DELAY | | |
|--------------------|-------------|--------|---------|
| | (nsec) | | |
| | @-55°C | @+25°C | @+125°C |
| 10 | 0.07 | 0.07 | 0.08 |
| 50 | 0.06 | 0.06 | 0.07 |
| 100 | 0.05 | 0.06 | 0.06 |
| 300 | 0.05 | 0.05 | 0.06 |
| 500 | 0.05 | 0.05 | 0.05 |
| 700 | 0.05 | 0.05 | 0.05 |
| 900 | 0.05 | 0.05 | 0.05 |
| 1000 | 0.05 | 0.05 | 0.05 |
| 1200 | 0.05 | 0.05 | 0.05 |
| 1400 | 0.05 | 0.05 | 0.05 |
| 1600 | 0.05 | 0.05 | 0.05 |
| 1800 | 0.05 | 0.05 | 0.05 |
| 2000 | 0.05 | 0.05 | 0.05 |
| 2200 | 0.05 | 0.05 | 0.05 |
| 2400 | 0.05 | 0.05 | 0.05 |
| 2600 | 0.05 | 0.05 | 0.06 |
| 2800 | 0.05 | 0.05 | 0.06 |
| 3000 | 0.05 | 0.05 | 0.06 |
| 3200 | 0.05 | 0.05 | 0.06 |
| 3400 | 0.05 | 0.05 | 0.06 |
| 3600 | 0.05 | 0.05 | 0.06 |
| 3800 | 0.05 | 0.05 | 0.06 |
| 4000 | 0.05 | 0.06 | 0.06 |
| 4500 | 0.05 | 0.06 | 0.06 |
| 5000 | 0.05 | 0.06 | 0.06 |
| 5500 | 0.06 | 0.06 | 0.06 |
| 6000 | 0.06 | 0.06 | 0.06 |
| 6500 | 0.06 | 0.06 | 0.06 |
| 7000 | 0.06 | 0.06 | 0.07 |
| 7500 | 0.07 | 0.07 | 0.07 |
| 8000 | 0.07 | 0.07 | 0.07 |
| 8500 | 0.07 | 0.07 | 0.07 |
| 9000 | 0.07 | 0.08 | 0.08 |
| 9500 | 0.08 | 0.08 | 0.08 |
| 10000 | 0.08 | 0.08 | 0.09 |
| 10500 | 0.09 | 0.09 | 0.09 |
| 11000 | 0.10 | 0.10 | 0.10 |
| 11500 | 0.10 | 0.11 | 0.11 |
| 12000 | 0.11 | 0.12 | 0.12 |
| 12900 | 0.14 | 0.15 | 0.16 |

Typical Performance Curves

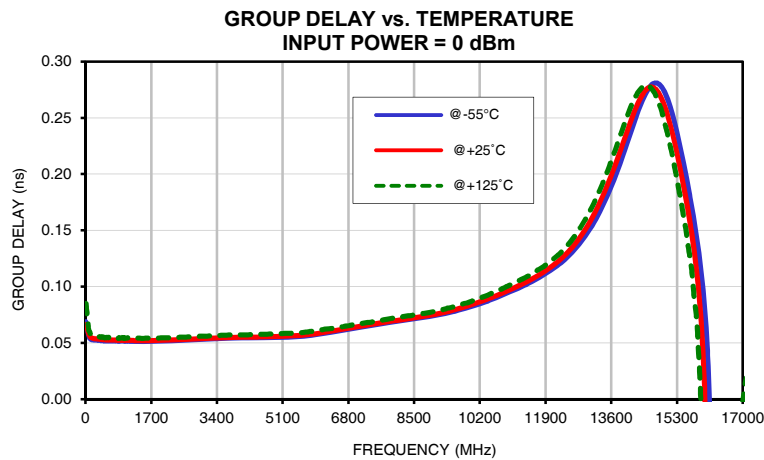
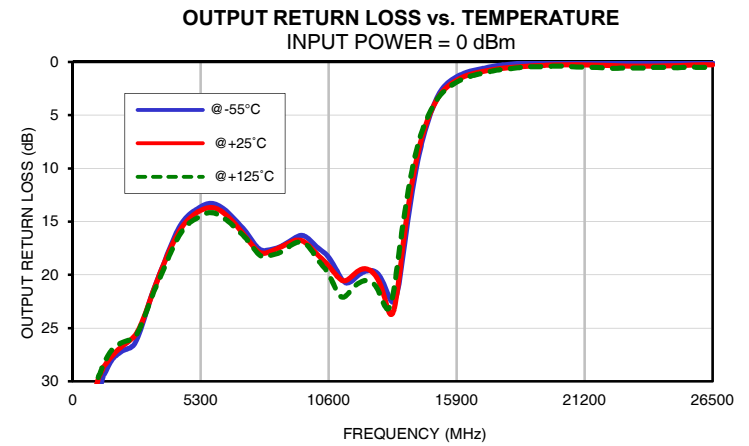
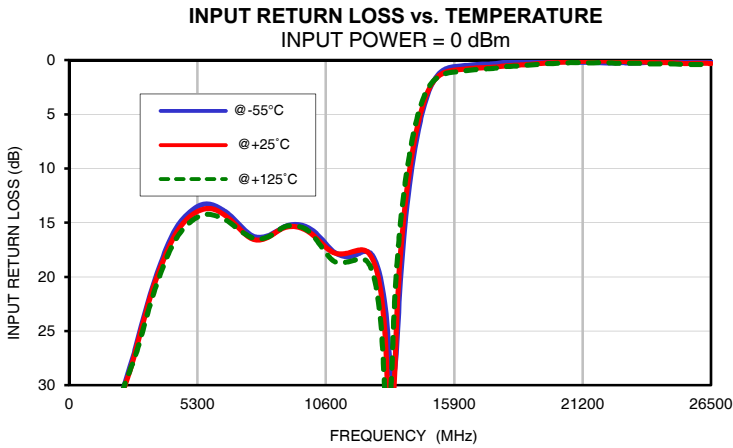
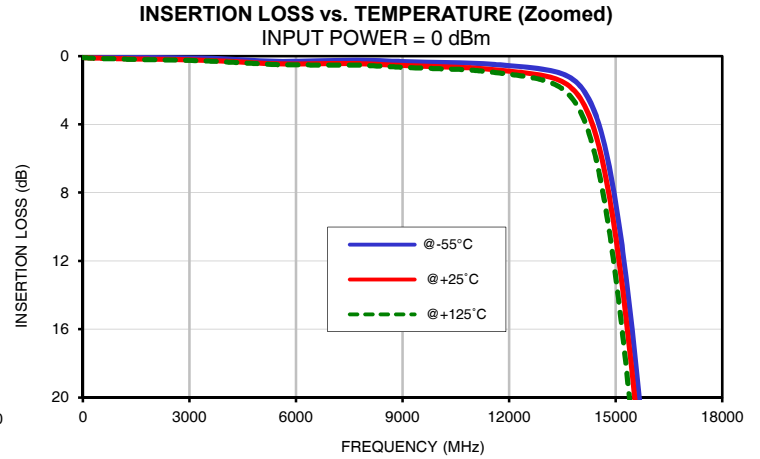
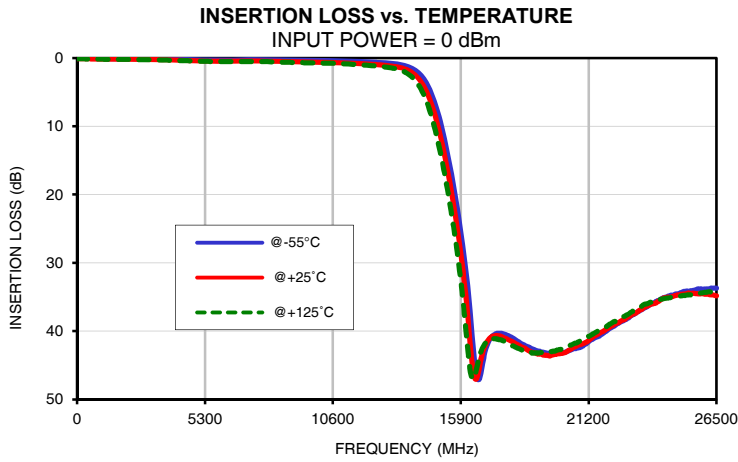

Outline Dimensions

JC0603C-1

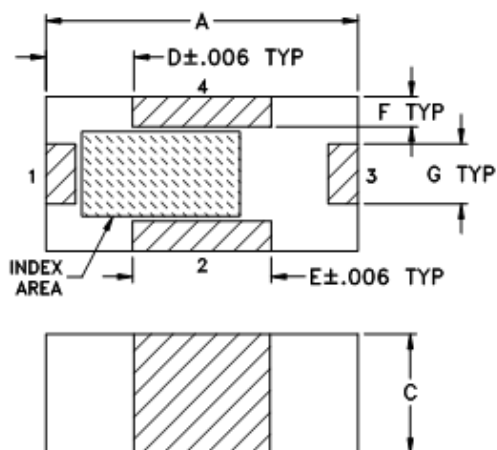

PCB Land Pattern

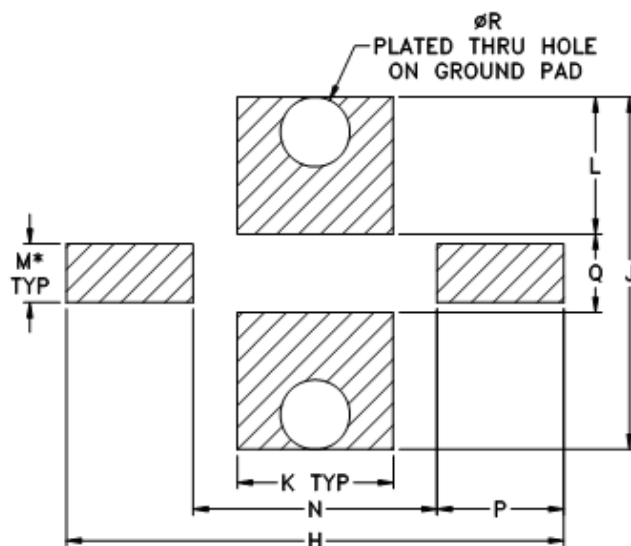

Suggested Layout,
Tolerance to be within $\pm .002$

| CASE # | A | B | C | D | E | F | G | H | J | K | L |
|-----------|----------------|----------------|----------------|----------------|----------------|----------------|----------------|----------------|----------------|----------------|----------------|
| JC0603C-1 | .063 (1.60) | .031 (0.80) | .024 (0.60) | .018 (0.45) | .028 (0.70) | .006 (0.15) | .012 (0.30) | .100 (2.54) | .071 (1.80) | .032 (0.80) | .028 (0.70) |

| CASE # | M* | N | P | Q | R | WT. GRAMS |
|-----------|----------------|----------------|----------------|----------------|----------------|-----------|
| JC0603C-1 | .012 (0.30) | .049 (1.24) | .026 (0.65) | .016 (0.40) | .014 (0.35) | .005 |

Dimensions are in inches (mm). Tolerances: 3 Pl. $\pm .004$

Notes:

1. Open style, ceramic base.
2. Termination finish:
For RoHS Case Styles: Tin plate over Nickel plate. All models, (+) suffix.
- 3.* - Line width should be designed to match 50 OHMS characteristic impedance, depending on PCB material & thickness.



P.O. Box 350166, Brooklyn, New York 11235-0003 (718) 934-4500 Fax (718) 332-4661 For detailed performance specs & shopping online see Mini-Circuits web site



The Design Engineers Search Engine Provides ACTUAL Data Instantly From MINI-CIRCUITS At: www.minicircuits.com

RF/IF MICROWAVE COMPONENTS

Tape & Reel Packaging TR-F74

DEVICE ORIENTATION IN T&R

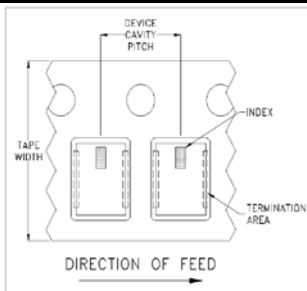

ILLUSTRATION 1

Applicable Case Styles

GE0805C-1
GE0805C-1AP
JV1210C-1
GU2939

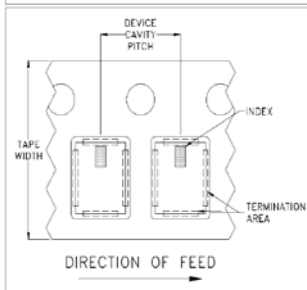

ILLUSTRATION 2

Applicable Case Styles

JV1210C
JV1210C-2
JV1210C-3
JV1210C-4
JV1210C-5
JV1210C-6
JV1210C-11

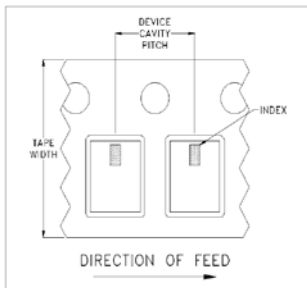

ILLUSTRATION 3

Applicable Case Styles

JC0603C-8
JV1210C-7
JV1210C-8
JV1210C-9
JV1210C-10
JV1210C-13
GE0805C-13

| Tape Width, mm | Device Cavity Pitch, mm | Real Size, inches | Devices per Reel | |
|-------------------|----------------------------|----------------------|--|------|
| 8 | 4 | 7 | Small quantity standards (see note) | 20 |
| | | | | 50 |
| | | | | 100 |
| | | | | 200 |
| | | | | 500 |
| | | | Standard | 1000 |
| | | | | 2000 |
| | | | 4000 | |

Note: Small reel availability varies by model. Refer to pricing and availability on individual model dashboard.

Mini-Circuits carrier tape materials provide protection from ESD (Electro-Static Discharge) during handling and transportation. Tapes are static dissipative and comply with industry standards EIA-481/EIA-541.

Go to: www.minicircuits.com/pages/pdfs/tape.pdf



INTERNET <http://www.minicircuits.com>

P.O. Box 350166, Brooklyn, New York 11235-0003 (718) 934-4500 Fax (718) 332-4661

Distribution Centers NORTH AMERICA 800-654-7949 • 417-335-5935 • Fax 417-335-5945 • EUROPE 44-1252-832600 • Fax 44-1252-837010

Mini-Circuits ISO 9001 & ISO 14001 Certified

THIRD ANGLE PROJECTION

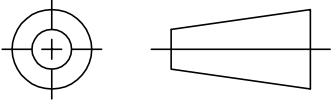

REVISIONS

| REV OR | ECN No. | DESCRIPTION | DATE | DR | AUTH |
|--------|---------|-------------|--------|-----|------|
| | M176778 | NEW RELEASE | DEC 19 | DDR | VC |
| | | | | | |
| | | | | | |

SUGGESTED MOUNTING CONFIGURATION
FOR JC0603C-1 CASE STYLE

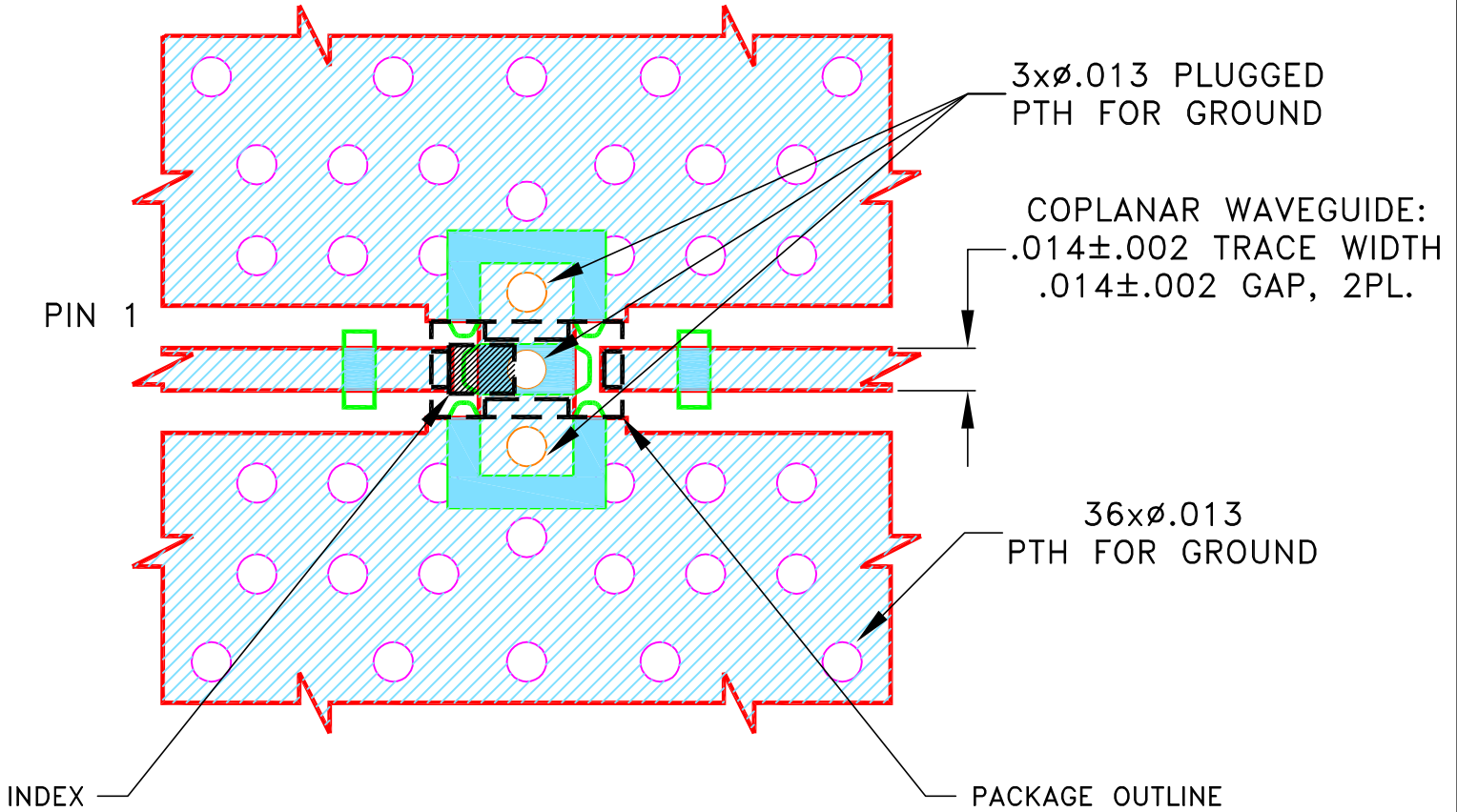

NOTES:

- COPLANAR WAVEGUIDE PARAMETERS ARE SHOWN FOR ROGERS (R04350B) WITH DIELECTRIC THICKNESS $.0066 \pm .0007$. COPPER: 1/2 Oz. EACH SIDE. FOR OTHER MATERIALS TRACE WIDTH AND GAP MAY NEED TO BE MODIFIED.
- BOTTOM SIDE OF THE PCB IS CONTINUOUS GROUND PLANE.

- DENOTES PCB COPPER PATTERN WITH SMOBC (SOLDER MASK OVER BARE COPPER)
- DENOTES PCB COPPER PATTERN FREE OF SOLDERMASK

| UNLESS OTHERWISE SPECIFIED | INITIALS | DATE |
|----------------------------|---------------|-----------|
| DIMENSIONS ARE IN INCHES | DRAWN: DDR | 14 DEC 19 |
| TOLERANCES ON: | CHECKED: RV | 14 DEC 19 |
| 2 PL DECIMALS ± | APPROVED: RKS | 14 DEC 19 |
| 3 PL DECIMALS ± .005 | | |
| ANGLES ± | | |
| FRACTIONS ± | | |

Mini-Circuits® 13 Neptune Avenue
Brooklyn NY 11235

PL, JC0603C-1, TB-1124+

Mini-Circuits®
THIS DOCUMENT AND ITS CONTENTS ARE THE PROPERTY OF MINI-CIRCUITS. EXCEPT FOR USE EXPRESSLY GRANTED, IN WRITING, TO ITS VENDORS, VENDEE AND THE UNITED STATES GOVERNMENT, MINI-CIRCUITS RESERVES ALL PROPRIETARY DESIGN, USE, MANUFACTURING AND REPRODUCTION RIGHTS THERETO. THESE CONTENTS SHALL NOT BE USED, DUPLICATED OR DISCLOSED TO ANY OUTSIDE PARTY, IN WHOLE OR IN PART, WITHOUT WRITTEN PERMISSION OF MINI-CIRCUITS.

| SIZE | CODE IDENT | DRAWING NO: | REV: |
|-------|------------|-------------|---------------|
| A | 15542 | 98-PL-661 | OR |
| FILE: | 98PL661 | SCALE: 16:1 | SHEET: 1 OF 1 |

Evaluation Board and Circuit

TB-LFCW-1292+

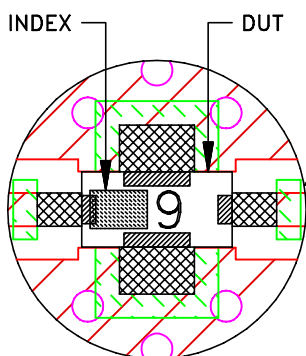
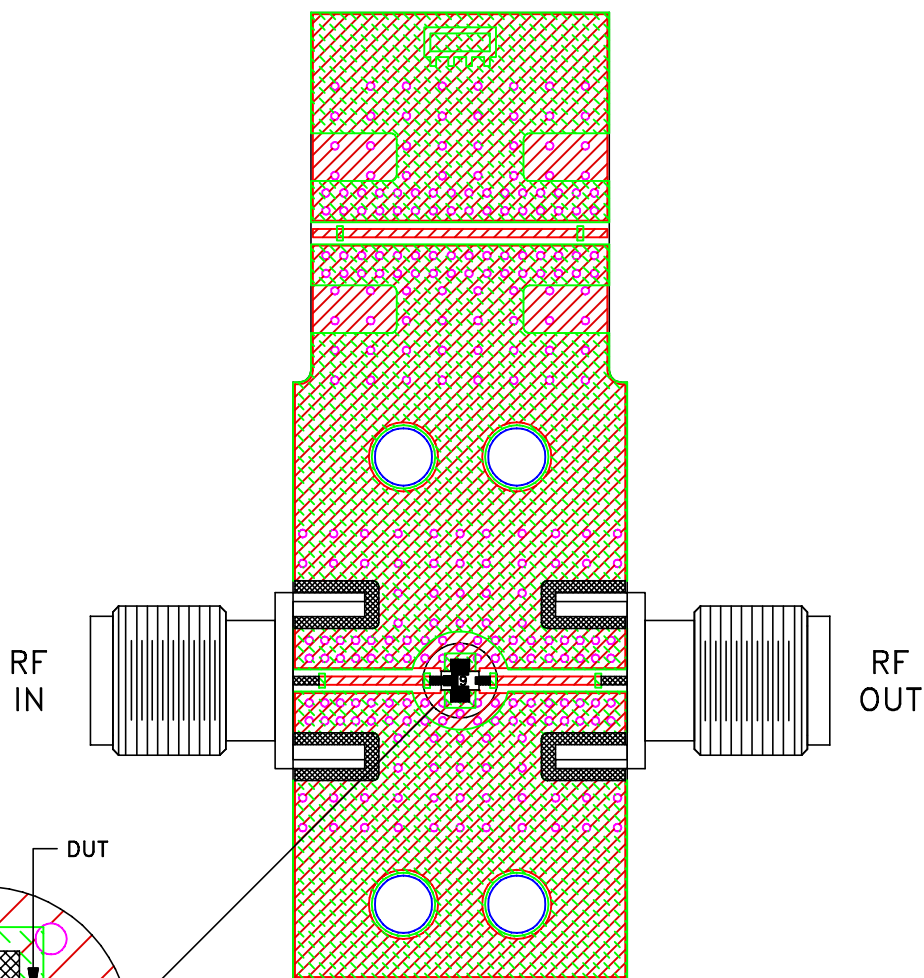

Schematic diagram

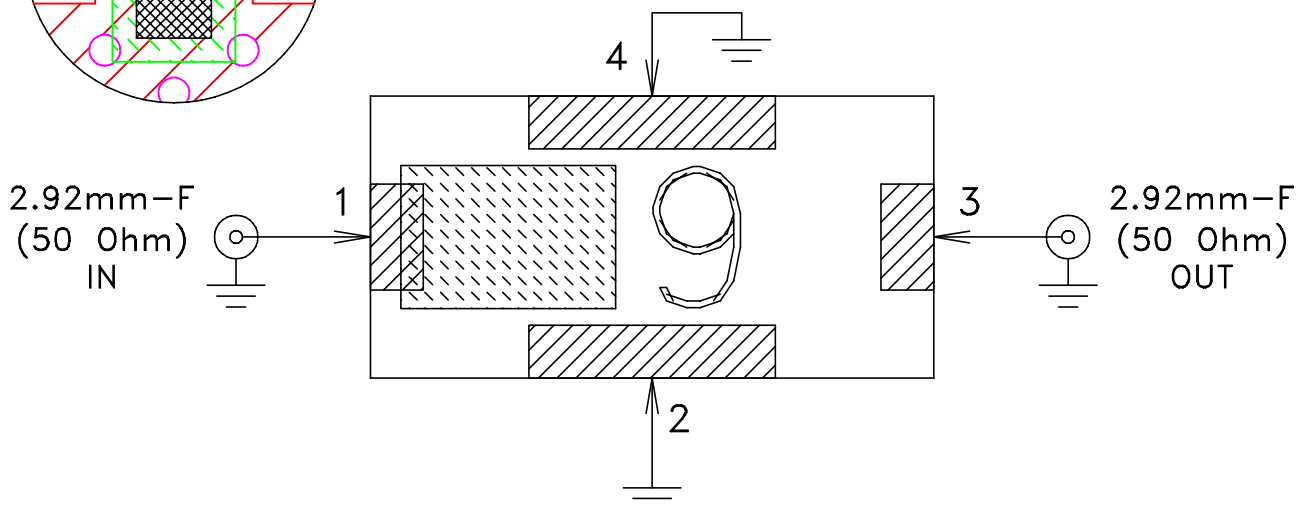

Notes:

1. PCB Material: ROGERS (RO4350B) OR Equivalent, Dielectric Constant= 3.48 ± 0.05

Dielectric Thickness: $.0066 \pm .0007$

2. 50 Ohm 2.92mm Female Connectors.

3. Connectors on the test board shall not be subjected to temperature greater than 200°C to avoid permanent damage to the connectors.

 **Mini-Circuits®**

All Mini-Circuits products are manufactured under exacting quality assurance and control standards, and are capable of meeting published specifications after being subjected to any or all of the following physical and environmental test.

| Specification | Test/Inspection Condition | Reference/Spec |
|----------------------------|---|--|
| Operating Temperature | -55° to 125° C Ambient Environment | Individual Model Data Sheet |
| Storage Temperature | -55° to 125° C Ambient Environment | Individual Model Data Sheet |
| Humidity | 90 to 95% RH, 240 hours, 50°C | MIL-STD-202, Method 103, Condition A, Except 50°C and end-point electrical test done within 12 hours |
| Solder Reflow Heat | Sn-Pb Eutectic Process 225°C peak Pb-Free Process 245° - 250°C peak | J-STD-020C, Table 4-1, 4-2 and 5-2, Figure 5-1 |
| Solderability | 10X Magnification | J-STD-002, Para 4.2.5, Test S, 95% Coverage |
| Vibration (High Frequency) | 20g peak, 10-2000 Hz, 12 times in each of three perpendicular directions (total 36) | MIL-STD-202, Method 204, Condition D |
| Mechanical Shock | 50g, 11 ms, 1/2-sine, 18 shocks: 3 each direction, each of 3 axes | MIL-STD-202, Method 213, Condition A |