

50Ω

DC to 10.6 GHz

The Big Deal

- Small size 0603 (1.6 x 0.8 mm)
- Low insertion loss, 2.1 dB typical
- Rejection 20 dB typical from 12 to 15.21 GHz
- Good power handling, 4W



CASE STYLE: JC0603C-1

Product Overview

Mini-Circuits' LFCW-1062+ is a Low Temperature Co-fired Ceramic (LTCC) low pass filter, designed in a very small, 0603 package. The multilayer construction provides high repeatability of performance. Small, wrap-around terminations minimize variations in performance due to parasitics. Covering DC – 10.6 GHz, these units offer low insertion loss, good rejection, and excellent power handling capability.

Key Features

Feature	Advantages
Small size 0603 (1.6 x 0.8 mm)	Allows for high layout density of circuit boards while minimizing the effects of parasitics.
Stop band rejection 20 dB typical over 12 –15.21 GHz	Provides good rejection in a tiny package, saving PCB space for customers.
Wrap-around terminations	Provides excellent solderability and easy visual inspection.
LTCC construction	Rugged package, well-suited for tough environments including high humidity and high temperature extremes.

Notes

- A. Performance and quality attributes and conditions not expressly stated in this specification document are intended to be excluded and do not form a part of this specification document.
 B. Electrical specifications and performance data contained in this specification document are based on Mini-Circuit's applicable established test performance criteria and measurement instructions.
 C. The parts covered by this specification document are subject to Mini-Circuits standard limited warranty and terms and conditions (collectively, "Standard Terms"); Purchasers of this part are entitled to the rights and benefits contained therein. For a full statement of the Standard Terms and the exclusive rights and remedies thereunder, please visit Mini-Circuits' website at www.minicircuits.com/MCLStore/terms.jsp

Ceramic Low Pass Filter

50Ω DC¹ to 10.6 GHz

LFCW-1062+



Generic photo used for illustration purposes only

CASE STYLE: JC0603C-1

Features

- Good power handling, 4W
- Small size 0603 (1.6 x 0.8 mm)
- 7 sections
- Temperature stable
- LTCC construction

+RoHS Compliant

The +Suffix identifies RoHS Compliance. See our web site for RoHS Compliance methodologies and qualifications

Applications

- Harmonic Rejection
- VHF/UHF transmitters / receivers
- lab use

Electrical Specifications^{1,2} at 25°C

Parameter	F#	Frequency (GHz)	Min.	Typ.	Max.	Unit
Pass Band	Insertion Loss	DC - F1	DC - 10.6	—	2.8	dB
	Freq. cut-off	F2	10.8	—	3.0	dB
	VSWR	DC - F1	DC - 10.6	—	2.2	:1
Stop Band	Rejection Loss	F3	12	—	20	dB
		F4 - F5	12.16 - 12.86	25	31	:1
		F6	15.21	—	20	dB

1 In Application where DC voltage is present at either input or output port, coupling capacitors are required.

2 Measured on Mini-Circuits Characterization Test Board TB-720+

Functional Schematic

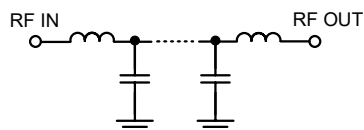

Maximum Ratings

Operating Temperature	-55°C to 100°C
Storage Temperature	-55°C to 100°C
RF Power Input ³	4W at 25°C

³Passband rating, derate linearly to 1.6W at 100°C ambient ([Reference AN-75-005](#))
Permanent damage may occur if any of these limits are exceeded.

Typical Frequency Response

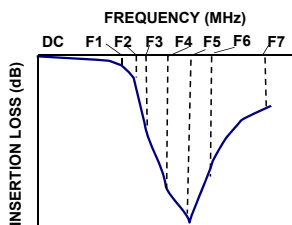

Typical Performance Data at 25°C

Frequency (GHz)	Insertion Loss (dB)	VSWR (:1)
0.01	0.07	1.00
0.50	0.10	1.03
1.00	0.13	1.07
3.00	0.23	1.21
5.00	0.24	1.01
7.00	0.44	1.38
9.00	0.69	1.34
10.00	1.00	1.18
10.60	1.56	1.38
11.10	3.10	1.69
12.00	32.69	15.76
12.16	35.14	21.74
12.86	32.64	44.06
13.86	26.86	86.35
15.21	21.54	100.15
18.00	16.11	31.94
20.00	15.72	49.40

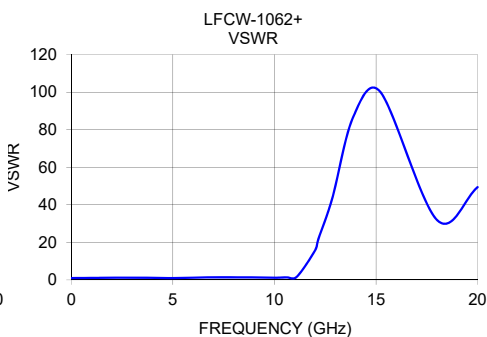
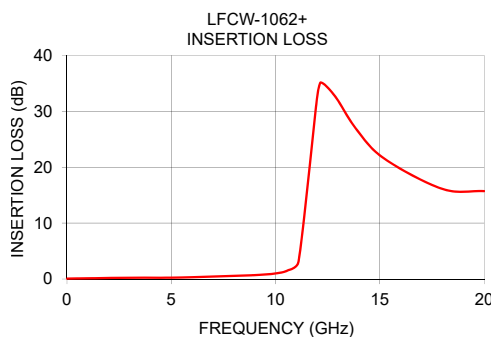

Notes

- Performance and quality attributes and conditions not expressly stated in this specification document are intended to be excluded and do not form a part of this specification document.
- Electrical specifications and performance data contained in this specification document are based on Mini-Circuit's applicable established test performance criteria and measurement instructions.
- The parts covered by this specification document are subject to Mini-Circuits standard limited warranty and terms and conditions (collectively, "Standard Terms"); Purchasers of this part are entitled to the rights and benefits contained therein. For a full statement of the Standard Terms and the exclusive rights and remedies thereunder, please visit Mini-Circuits' website at www.minicircuits.com/MCLStore/terms.jsp



www.minicircuits.com P.O. Box 350166, Brooklyn, NY 11235-0003 (718) 934-4500 sales@minicircuits.com

REV. C
ECO-011685
ED-15030/1
LFCW-1062+
MY/CP/AM
240813
Page 2 of 3

Pad Connections

INPUT	1
OUTPUT	3
GROUND	2,4

Product Marking: N/A

Evaluation Board MCL P/N: TB-720+
Suggested PCB Layout (PL-412)

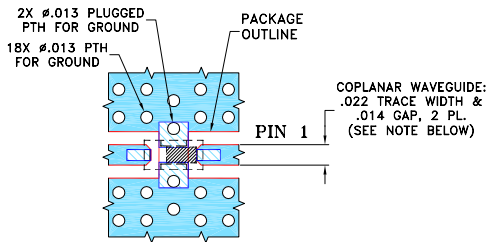

NOTES:

- TRACE WIDTH IS SHOWN FOR ROGERS R04350B WITH DIELECTRIC THICKNESS .010" ± .001"; COPPER: 1/2 OZ. EACH SIDE. FOR OTHER MATERIALS TRACE WIDTH AND GAP MAY NEED TO BE MODIFIED.
- BOTTOM SIDE OF THE PCB IS CONTINUOUS GROUND PLANE.

DENOTES PCB COPPER LAYOUT WITH SMOBC (SOLDER MASK OVER BARE COPPER).

DENOTES COPPER LAND PATTERN FREE OF SOLDER MASK.

Outline Drawing

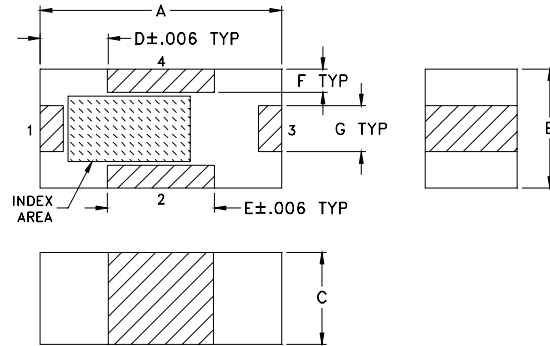

Outline Dimensions (^{inch}/_{mm})

A	B	C	D	E	F	G	wt
.063	.031	.024	.018	.028	.006	.012	grams
1.60	0.79	0.61	0.46	0.71	0.15	0.30	0.005

Notes

- Performance and quality attributes and conditions not expressly stated in this specification document are intended to be excluded and do not form a part of this specification document.
- Electrical specifications and performance data contained in this specification document are based on Mini-Circuit's applicable established test performance criteria and measurement instructions.
- The parts covered by this specification document are subject to Mini-Circuits standard limited warranty and terms and conditions (collectively, "Standard Terms"); Purchasers of this part are entitled to the rights and benefits contained therein. For a full statement of the Standard Terms and the exclusive rights and remedies thereunder, please visit Mini-Circuits' website at www.minicircuits.com/MCLStore/terms.jsp

Typical Performance Data

FREQ. (MHz)	INSERTION LOSS (dB)			INPUT RETURN LOSS (dB)			OUTPUT RETURN LOSS (dB)		
	@-55°C	@+25°C	@+100°C	@-55°C	@+25°C	@+100°C	@-55°C	@+25°C	@+100°C
	10.0	0.08	0.09	0.08	37.38	37.90	44.86	35.37	35.59
20.0	0.08	0.08	0.09	44.74	56.84	45.42	44.95	55.82	44.32
30.0	0.08	0.08	0.09	42.09	56.44	41.87	42.75	51.44	40.35
40.0	0.08	0.08	0.09	40.94	54.10	39.89	42.71	50.41	38.17
50.0	0.12	0.13	0.13	46.68	49.68	37.60	40.55	55.75	39.39
60.0	0.08	0.08	0.09	39.41	54.47	41.17	42.22	50.12	37.73
70.0	0.08	0.09	0.10	40.92	48.94	39.56	42.89	48.17	37.95
80.0	0.09	0.09	0.10	41.94	48.46	40.70	45.68	47.92	38.38
90.0	0.08	0.09	0.10	43.94	49.48	42.37	49.56	47.98	39.39
100.0	0.08	0.09	0.10	44.55	48.60	46.51	51.79	48.06	41.31
100.0	0.08	0.09	0.10	44.55	48.60	46.51	51.79	48.06	41.31
200.0	0.08	0.10	0.11	39.43	44.58	33.41	37.57	44.63	34.18
300.0	0.08	0.11	0.12	39.44	40.68	38.52	48.20	40.58	36.15
400.0	0.08	0.11	0.13	44.99	38.84	33.96	41.68	37.86	33.26
500.0	0.07	0.11	0.14	39.38	36.76	30.42	42.41	35.66	30.69
600.0	0.07	0.12	0.15	35.71	34.61	29.70	35.17	34.04	29.24
700.0	0.07	0.12	0.15	33.08	33.44	28.49	32.30	32.45	28.05
800.0	0.07	0.12	0.16	32.20	31.97	27.36	31.75	31.28	27.23
900.0	0.07	0.13	0.17	30.01	31.11	26.62	29.67	30.17	26.20
1000.0	0.07	0.13	0.17	29.82	30.20	26.06	29.04	29.43	25.83
1100.0	0.07	0.13	0.18	30.18	29.51	25.63	28.97	28.63	25.32
1200.0	0.06	0.14	0.19	29.76	28.63	25.09	28.42	27.80	24.79
1300.0	0.06	0.14	0.19	29.65	27.98	24.75	28.60	27.21	24.44
1400.0	0.06	0.14	0.20	28.92	27.46	24.62	27.81	26.59	24.21
1500.0	0.06	0.15	0.21	28.59	26.87	24.42	27.32	26.10	24.00
1600.0	0.06	0.15	0.21	28.14	26.26	24.24	26.90	25.49	23.75
1700.0	0.06	0.16	0.22	27.60	25.80	24.30	26.54	25.10	23.80
1800.0	0.06	0.16	0.23	27.20	25.47	24.37	26.16	24.66	23.73
1900.0	0.06	0.16	0.23	27.20	25.07	24.45	26.01	24.36	23.88
2000.0	0.06	0.17	0.24	27.06	24.63	24.45	25.88	23.86	23.74
2500.0	0.06	0.19	0.26	24.49	23.25	25.16	23.92	22.58	24.13
3000.0	0.07	0.20	0.29	21.56	22.97	26.26	21.34	22.35	24.85
3500.0	0.06	0.21	0.31	21.63	23.40	26.98	21.67	22.87	25.42
4000.0	0.06	0.22	0.34	21.72	24.73	28.20	21.90	24.30	26.62
4500.0	0.04	0.22	0.37	25.72	28.38	30.73	25.93	28.08	29.86
5000.0	0.03	0.23	0.39	38.85	36.07	35.10	36.97	39.77	39.83
5500.0	0.03	0.25	0.42	30.26	29.87	31.33	29.86	30.34	33.11
6000.0	0.04	0.29	0.48	27.83	23.17	23.68	27.84	22.99	23.34
6500.0	0.06	0.35	0.56	22.14	19.06	18.90	22.58	18.88	18.35
7000.0	0.11	0.43	0.67	18.43	16.39	16.27	18.69	16.20	15.84
7500.0	0.21	0.52	0.75	14.67	14.77	15.55	14.87	14.73	15.24
8000.0	0.34	0.59	0.80	12.50	14.14	16.07	12.66	14.18	15.93
8500.0	0.35	0.62	0.84	12.84	14.71	17.63	13.22	14.93	17.79
9000.0	0.32	0.64	0.91	15.52	17.52	20.36	16.09	18.13	21.43
9500.0	0.32	0.69	1.03	24.67	25.12	24.92	27.00	31.54	28.96
10000.0	0.48	0.96	1.30	21.00	17.86	21.53	21.28	18.05	21.65
10600.0	0.91	1.53	1.94	14.01	13.07	14.25	14.31	12.88	14.10
10800.0	1.08	1.73	2.24	15.44	14.82	16.10	15.24	14.13	14.92
11000.0	1.36	2.11	2.77	19.04	21.43	21.79	17.07	17.05	16.27
11100.0	1.58	2.53	3.30	23.84	18.02	17.34	17.80	14.86	13.95
11500.0	5.42	7.68	9.23	4.76	3.70	3.78	4.65	3.70	3.71
12000.0	16.92	22.84	28.52	1.13	1.46	1.53	4.22	3.34	2.68
12160.0	33.32	35.67	35.73	0.39	0.91	1.17	1.25	1.43	1.56
12500.0	34.84	34.17	35.38	0.02	0.60	0.87	0.22	0.71	1.03
12860.0	33.17	32.10	32.07	0.15	0.40	0.75	0.02	0.51	0.87
13000.0	33.06	31.00	30.94	0.20	0.38	0.72	0.03	0.48	0.82
13500.0	28.60	27.05	26.99	0.31	0.26	0.69	0.13	0.35	0.75
13860.0	25.82	25.05	24.52	0.31	0.25	0.67	0.13	0.32	0.67
14000.0	25.37	24.51	23.86	0.32	0.21	0.67	0.15	0.27	0.64
14500.0	22.18	22.48	21.64	0.34	0.19	0.67	0.18	0.21	0.54
15000.0	19.68	20.79	20.52	0.37	0.18	0.65	0.25	0.17	0.45
15210.0	18.61	20.10	20.27	0.32	0.18	0.63	0.25	0.14	0.42
15500.0	17.84	19.30	20.08	0.32	0.19	0.63	0.26	0.16	0.37
16000.0	17.33	18.33	19.97	0.34	0.22	0.59	0.29	0.16	0.37
16500.0	17.56	17.47	19.62	0.37	0.29	0.60	0.32	0.19	0.40
17000.0	17.57	16.86	18.89	0.32	0.33	0.71	0.36	0.21	0.49
17500.0	17.34	16.52	17.91	0.30	0.44	0.89	0.33	0.22	0.56
18000.0	16.54	16.32	16.60	0.19	0.52	1.18	0.31	0.22	0.76
18500.0	15.19	16.19	15.41	0.06	0.62	1.49	0.22	0.28	0.92
19000.0	13.86	16.24	14.77	0.23	0.62	1.82	0.14	0.28	1.09
19500.0	13.00	16.47	15.06	0.27	0.65	1.84	0.03	0.30	1.06
20000.0	13.16	16.59	15.95	0.13	0.60	1.49	0.03	0.27	0.93



Typical Performance Data

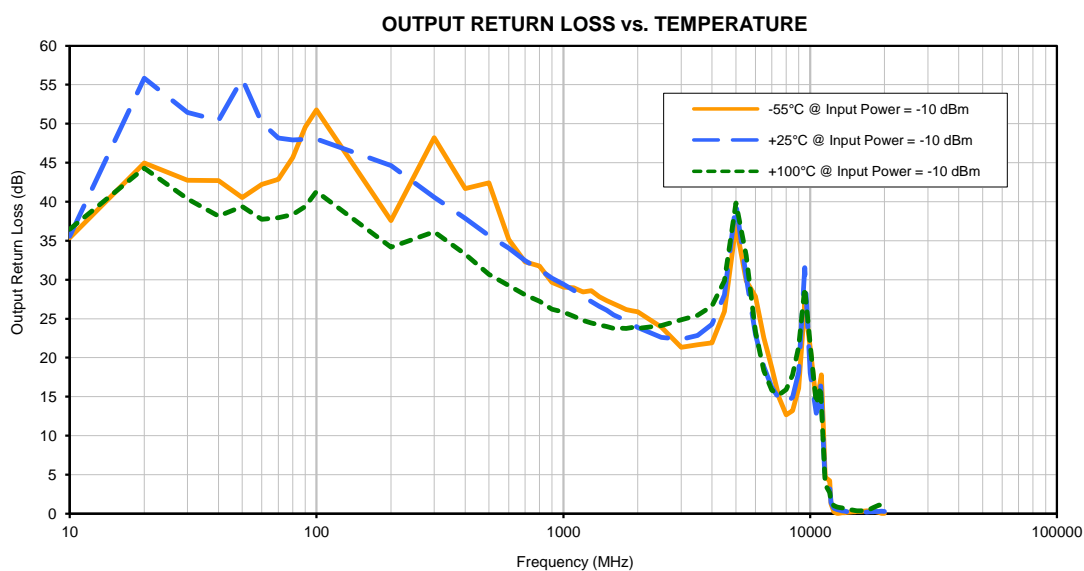
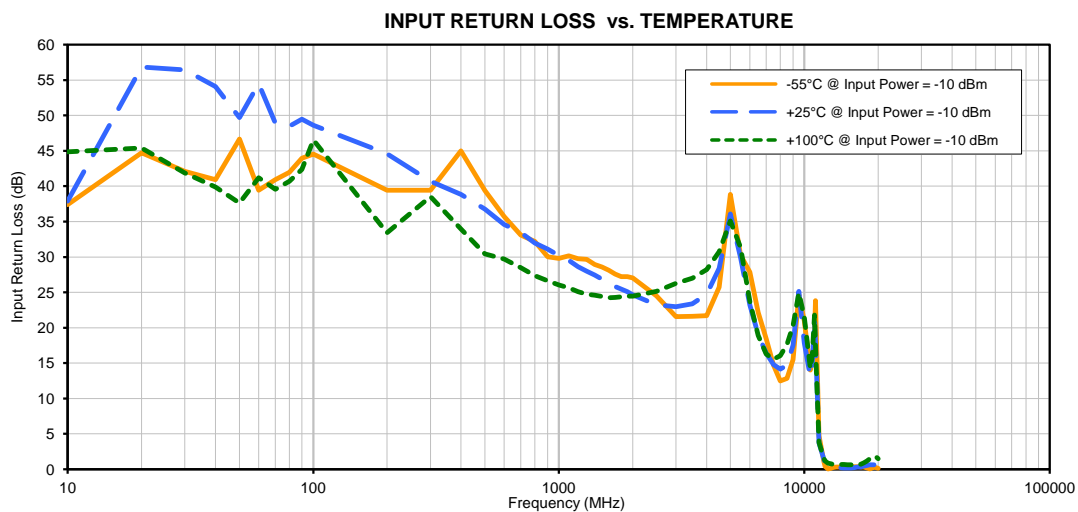
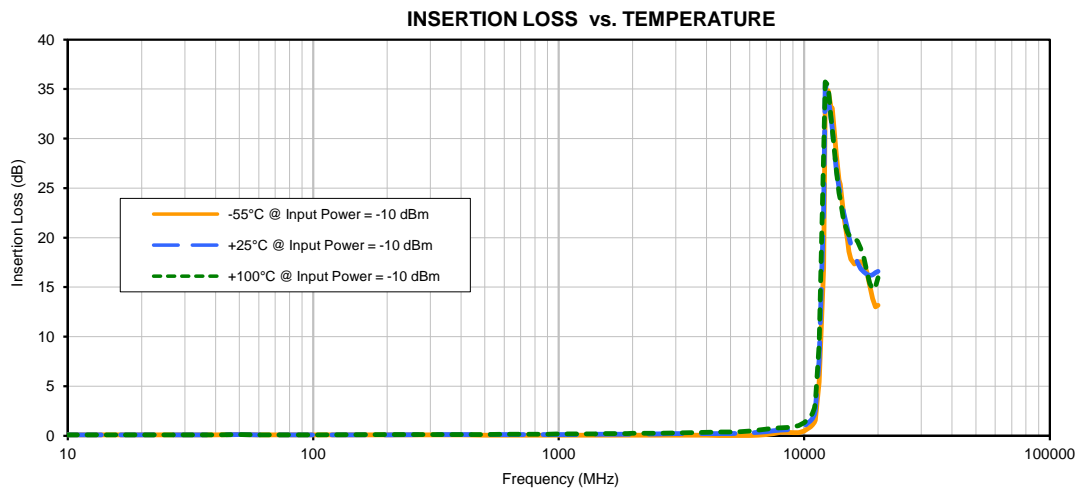

Outline Dimensions

JC0603C-1

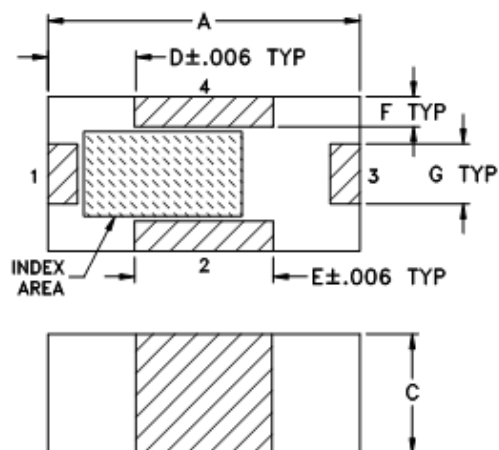

PCB Land Pattern

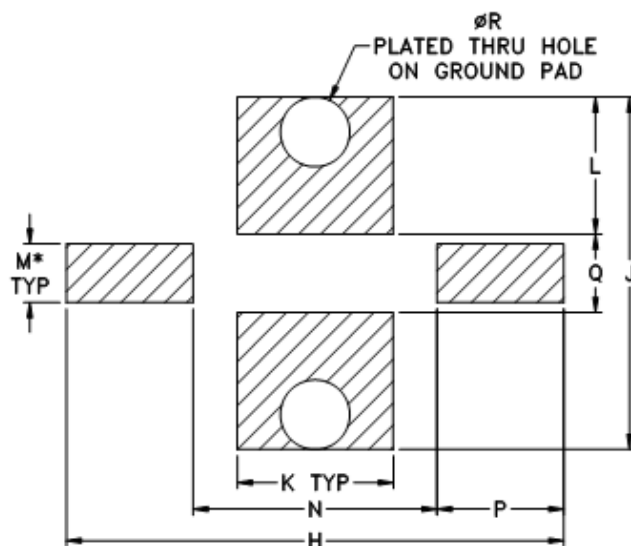

Suggested Layout,
Tolerance to be within $\pm .002$

CASE #	A	B	C	D	E	F	G	H	J	K	L
JC0603C-1	.063 (1.60)	.031 (0.80)	.024 (0.60)	.018 (0.45)	.028 (0.70)	.006 (0.15)	.012 (0.30)	.100 (2.54)	.071 (1.80)	.032 (0.80)	.028 (0.70)

CASE #	M*	N	P	Q	R	WT. GRAMS
JC0603C-1	.012 (0.30)	.049 (1.24)	.026 (0.65)	.016 (0.40)	.014 (0.35)	.005

Dimensions are in inches (mm). Tolerances: 3 Pl. $\pm .004$

Notes:

1. Open style, ceramic base.
2. Termination finish:
For RoHS Case Styles: Tin plate over Nickel plate. All models, (+) suffix.
- 3.* - Line width should be designed to match 50 OHMS characteristic impedance, depending on PCB material & thickness.



P.O. Box 350166, Brooklyn, New York 11235-0003 (718) 934-4500 Fax (718) 332-4661 For detailed performance specs & shopping online see Mini-Circuits web site



The Design Engineers Search Engine Provides ACTUAL Data Instantly From MINI-CIRCUITS At: www.minicircuits.com

RF/MICROWAVE COMPONENTS

Tape & Reel Packaging TR-F74

DEVICE ORIENTATION IN T&R

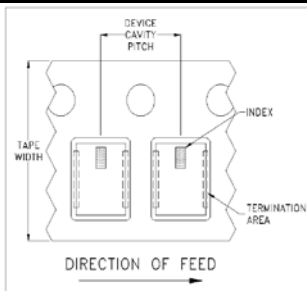

ILLUSTRATION 1

Applicable Case Styles

GE0805C-1
 GE0805C-1AP
 JV1210C-1
 GU2939

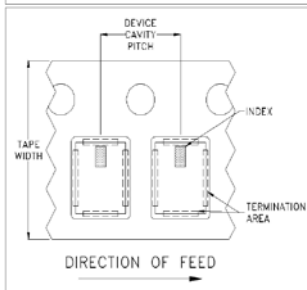

ILLUSTRATION 2

Applicable Case Styles

JV1210C
 JV1210C-2
 JV1210C-3
 JV1210C-4
 JV1210C-5
 JV1210C-6
 JV1210C-11

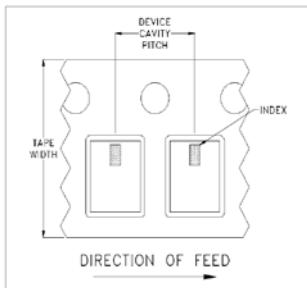

ILLUSTRATION 3

Applicable Case Styles

JC0603C-8
 JV1210C-7
 JV1210C-8
 JV1210C-9
 JV1210C-10
 JV1210C-13
 GE0805C-13

Tape Width, mm	Device Cavity Pitch, mm	Real Size, inches	Devices per Reel	
8	4	7	Small quantity standards (see note)	20
				50
				100
				200
				500
			Standard	1000
				2000
			4000	

Note: Small reel availability varies by model. Refer to pricing and availability on individual model dashboard.

Mini-Circuits carrier tape materials provide protection from ESD (Electro-Static Discharge) during handling and transportation. Tapes are static dissipative and comply with industry standards EIA-481/EIA-541.

Go to: www.minicircuits.com/pages/pdfs/tape.pdf



INTERNET <http://www.minicircuits.com>

P.O. Box 350166, Brooklyn, New York 11235-0003 (718) 934-4500 Fax (718) 332-4661

Distribution Centers NORTH AMERICA 800-654-7949 • 417-335-5935 • Fax 417-335-5945 • EUROPE 44-1252-832600 • Fax 44-1252-837010

Mini-Circuits ISO 9001 & ISO 14001 Certified

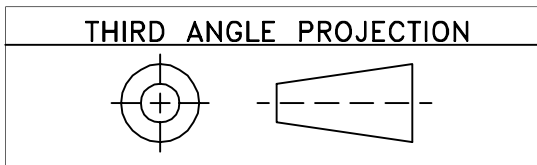

REVISIONS					
REV OR	ECN No.	DESCRIPTION	DATE	DR	AUTH
	M144975	NEW RELEASE	02/04/14	AV	RS

**SUGGESTED MOUNTING CONFIGURATION
FOR JC0603C-1 CASE STYLE, "04FL01" PIN CODE**

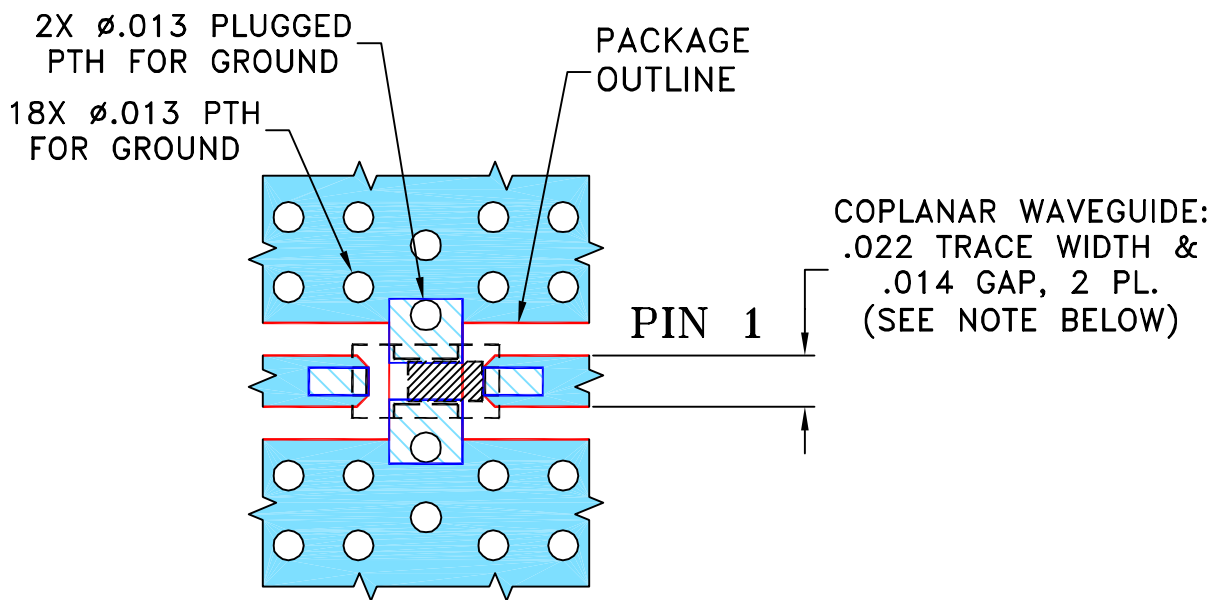

NOTES:

1. TRACE WIDTH IS SHOWN FOR ROGERS RO4350B WITH DIELECTRIC THICKNESS .010" ± .001". COPPER: 1/2 OZ. EACH SIDE. FOR OTHER MATERIALS TRACE WIDTH AND GAP MAY NEED TO BE MODIFIED.
2. BOTTOM SIDE OF THE PCB IS CONTINUOUS GROUND PLANE.



DENOTES PCB COPPER LAYOUT WITH SMOBC (SOLDER MASK OVER BARE COPPER).

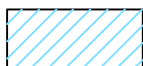

DENOTES COPPER LAND PATTERN FREE OF SOLDER MASK.

UNLESS OTHERWISE SPECIFIED	INITIALS	DATE
DIMENSIONS ARE IN INCHES TOLERANCES ON: 2 PL DECIMALS ± 3 PL DECIMALS ± .005 ANGLES ± FRACTIONS ±	DRAWN	AV 01/24/14
	CHECKED	IL 02/03/14
	APPROVED	RS 02/04/14



Mini-Circuits®

13 Neptune Avenue
Brooklyn NY 11235

PL, 04FL01, JC0603C-1, TB-720+

Mini-Circuits®
THIS DOCUMENT AND ITS CONTENTS ARE THE PROPERTY OF MINI-CIRCUITS. EXCEPT FOR USE EXPRESSLY GRANTED, IN WRITING, TO ITS VENDORS, VENDEE AND THE UNITED STATES GOVERNMENT, MINI-CIRCUITS RESERVES ALL PROPRIETARY DESIGN, USE, MANUFACTURING AND REPRODUCTION RIGHTS THERETO. THESE CONTENTS SHALL NOT BE USED, DUPLICATED OR DISCLOSED TO ANY OUTSIDE PARTY, IN WHOLE OR IN PART, WITHOUT WRITTEN PERMISSION OF MINI-CIRCUITS.

ASHEETA1.DWG REV:A DATE:01/12/95

SIZE	CODE IDENT	DRAWING NO:	REV:
A	15542	98-PL-412	OR
FILE:	98PL412	SCALE: 12:1	SHEET: 1 OF 1

Evaluation Board and Circuit

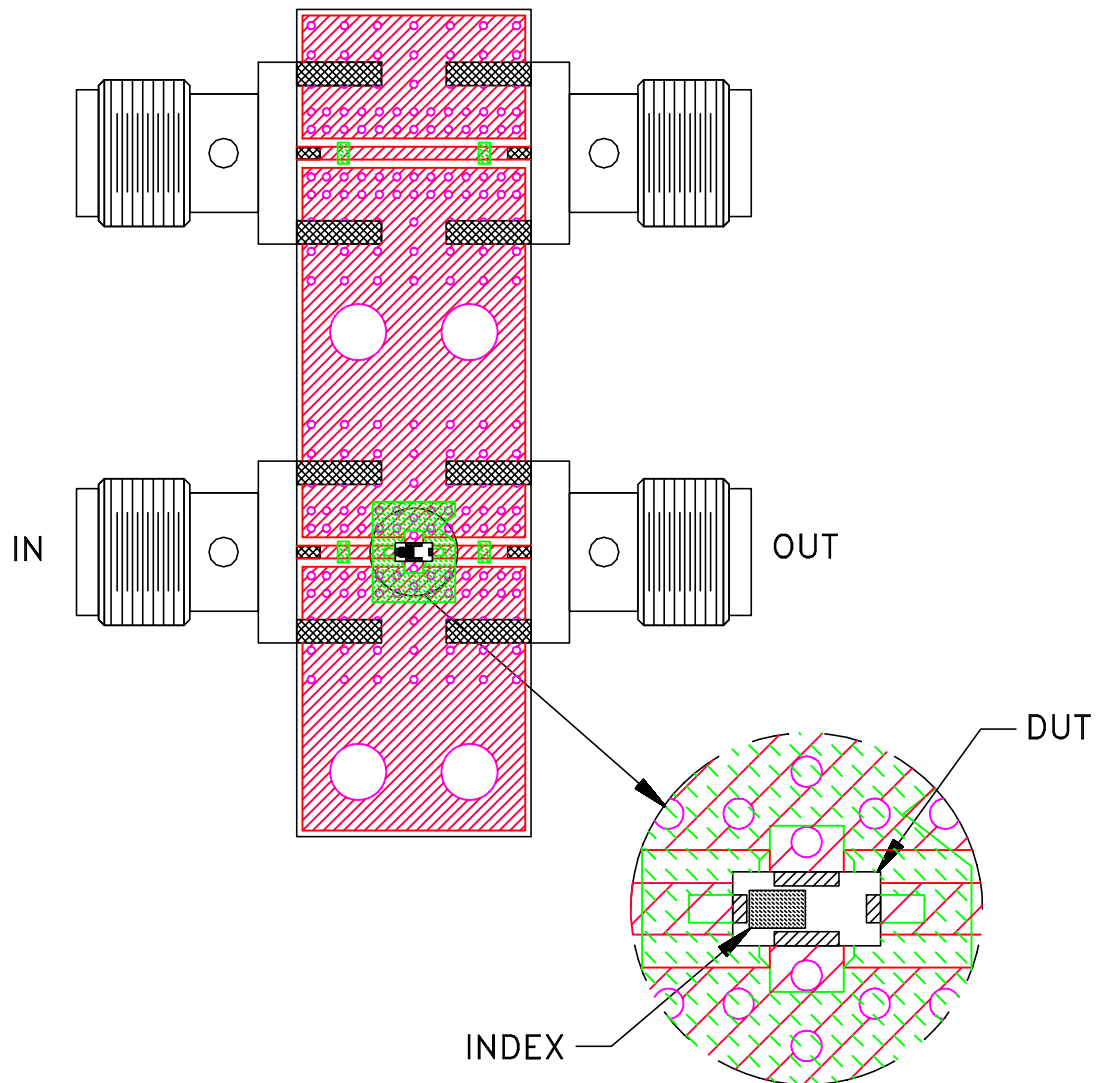

TB-720+

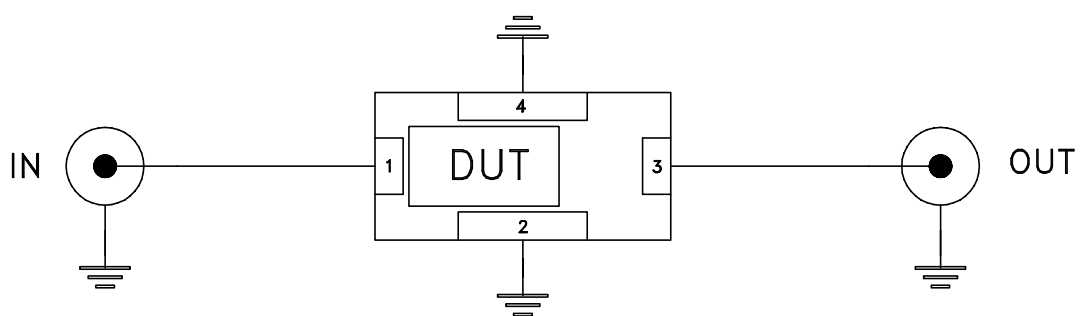

Schematic Diagram

Notes:

1. 50 Ohm 2.92 mm End Launch Female connectors.
2. PCB Material: R04350 or equivalent,
Dielectric Constant=3.5, Thickness=.010 inch.

 **Mini-Circuits®**

All Mini-Circuits products are manufactured under exacting quality assurance and control standards, and are capable of meeting published specifications after being subjected to any or all of the following physical and environmental test.

Specification	Test/Inspection Condition	Reference/Spec
Operating Temperature	-55° to 100°C Ambient Environment	Individual Model Data Sheet
Storage Temperature	-55° to 100° C Ambient Environment	Individual Model Data Sheet
Humidity	90 to 95% RH, 240 hours, 50°C	MIL-STD-202, Method 103, Condition A, Except 50°C and end-point electrical test done within 12 hours
Solder Reflow Heat	Sn-Pb Eutetic Process: 225°C peak Pb-Free Process 245° - 250°C peak	J-STD-020, Table 4-1, 4-2 and 5-2, Figure 5-1
Solderability	10X Magnification	J-STD-002, Para 4.2.5, Test S, 95% Coverage
Vibration (High Frequency)	20g peak, 10-2000 Hz, 12 times in each of three perpendicular directions (total 36)	MIL-STD-202, Method 204, Condition D
Mechanical Shock	50g, 11 ms, 1/2-sine, 18 shocks: 3 each direction, each of 3 axes	MIL-STD-202, Method 213, Condition A