



CERAMIC

Low Pass Filter

LFCN-113+

Mini-Circuits

50Ω DC¹ to 11000 MHz

FEATURES

- Excellent power handling, 8W
- Small size, 0.12" x .06"
- 7 sections
- Temperature stable
- Hermetically sealed
- LTCC construction
- Protected by U.S. Patent 6,943,646

APPLICATIONS

- Harmonic rejection
- VHF/UHF transmitters/receivers
- Lab use

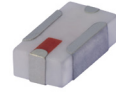

Generic photo used for illustration purposes only

CASE STYLE: FV1206-4

+RoHS Compliant

The +Suffix identifies RoHS Compliance. See our web site for RoHS Compliance methodologies and qualifications

PRODUCT OVERVIEW

The LFCN-113+ Low Pass Filter gives microwave communication system designers the ability to reject unwanted harmonics using defined RF parameters. The multilayer construction gives high repeatability of performance. Small wrap-around terminations minimize variations in performance due to parasitics. Covering DC-11000 MHz, these units offer low insertion loss and good rejection.

KEY FEATURES

Feature	Advantages
Small Size (3.20mm x1.6 mm)	Allows for high layout density of circuit boards, while minimizing affects of parasitics.
Rejection peaks at harmonic frequencies	Provides good rejection of signals at harmonic frequencies, for improved system performance.
Wrap around termination	Provides excellent solderability and easy visual inspection capability.
LTCC construction	Provides a rugged package that is well suited for tough environments including high humidity and high temperature extremes.

REV. F
ECO-011891
LFCN-113+
AD/CP/AM
220209





CERAMIC

Low Pass Filter

LFCN-113+

ELECTRICAL SPECIFICATIONS^{1,2} AT 25°C

Parameter	F#	Frequency (MHz)	Min.	Typ.	Max.	Units	
Passband	Insertion Loss	DC-F1	DC-10800	—	—	2.5	dB
	Freq. Cut-Off	F2	12250	—	3.0	—	dB
	VSWR	DC-F1	DC-10800	—	1.6	—	:1
Stop Band	Rejection Loss	F3	14000	20	—	—	dB
		F4-F5	14500-20000	—	40	—	dB
	VSWR	F3-F6	14500-20000	—	17	—	:1

1. In Application where DC voltage is present at either input or output ports, coupling capacitors are required.
2. Measured on Mini-Circuits Characterization Test Board TB-637+.

MAXIMUM RATINGS

Parameter	Ratings
Operating temperature	-55°C to 100°C
Storage temperature	-55°C to 100°C
RF Power Input ³	8 W max. at 25°C

3. Passband rating, derate linearly to 3W at 100°C ambient. Permanent damage may occur if any of these limits are exceeded.

TYPICAL FREQUENCY RESPONSE

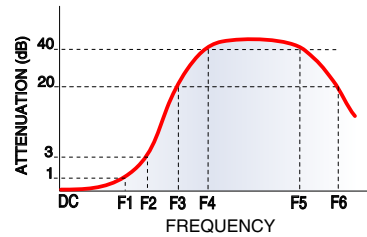

FUNCTIONAL SCHEMATIC

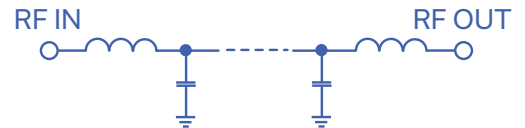



CERAMIC

Low Pass Filter

LFCN-113+

PIN CONNECTIONS

RF IN	1
RF OUT	3
GROUND	2,4

PRODUCT MARKING: AN

DEMO BOARD MCL P/N: TB-637
SUGGESTED PCB LAYOUT (PL-530)

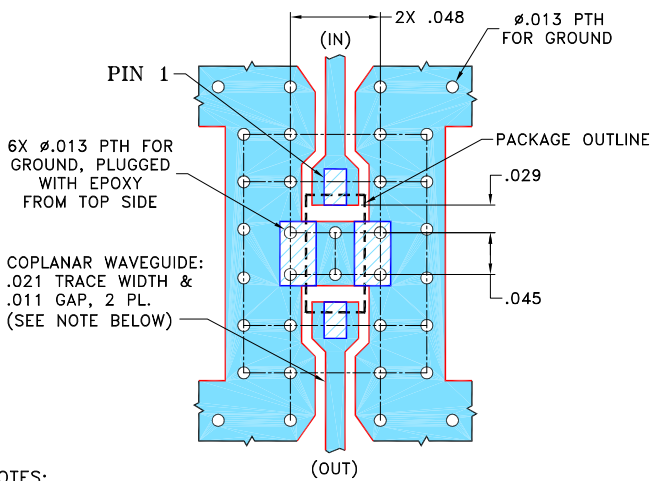

NOTES:

- TRACE WIDTH & GAP ARE SHOWN FOR ROGERS R04350B WITH DIELECTRIC THICKNESS $.010 \pm .001$; COPPER: 1/2 OZ. EACH SIDE. FOR OTHER MATERIALS TRACE WIDTH MAY NEED TO BE MODIFIED.
- BOTTOM SIDE OF THE PCB IS CONTINUOUS GROUND PLANE.

- DENOTES PCB COPPER LAYOUT WITH SMOBC (SOLDER MASK OVER BARE COPPER)
- DENOTES COPPER LAND PATTERN FREE OF SOLDER MASK

OUTLINE DRAWING

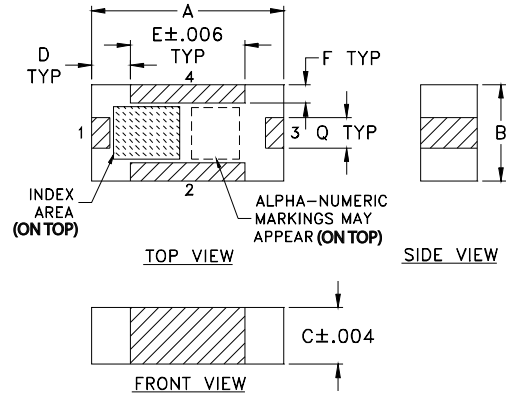

PCB Land Pattern

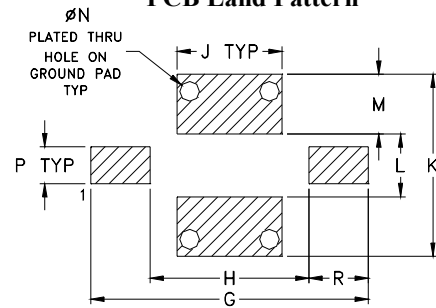

Suggested Layout,
Tolerance to be within $\pm .002$

OUTLINE DIMENSIONS (Inches / mm)

A	B	C	D	E	F	G	H	J
.126	.063	.037	.026	.075	.012	.182	.104	.069
3.20	1.60	0.94	0.66	1.91	0.30	4.62	2.64	1.75
K	L	M	N	P	Q	R	wt	
.119	.041	.039	.013	.024	.020	.039	grams	
3.02	1.04	0.99	0.33	0.61	0.51	0.99	.020	

TAPE & REEL INFORMATION: F75



CERAMIC

Low Pass Filter

LFCN-113+

TYPICAL PERFORMANCE DATA AT 25°C

Frequency (MHz)	Insertion Loss (dB)	VSWR (:1)
10.00	0.11	1.01
1000.00	0.27	1.32
1210.00	0.32	1.39
1410.00	0.37	1.47
2010.00	0.50	1.64
3200.00	0.47	1.59
3800.00	0.35	1.18
4200.00	0.35	1.18
5000.00	0.60	1.61
6260.00	0.80	1.77
8450.00	0.97	1.74
10050.00	0.97	1.74
11060.00	1.57	1.87
13290.00	30.98	27.77
15410.00	38.04	78.16
18650.00	49.07	66.83
20000.00	35.74	71.79

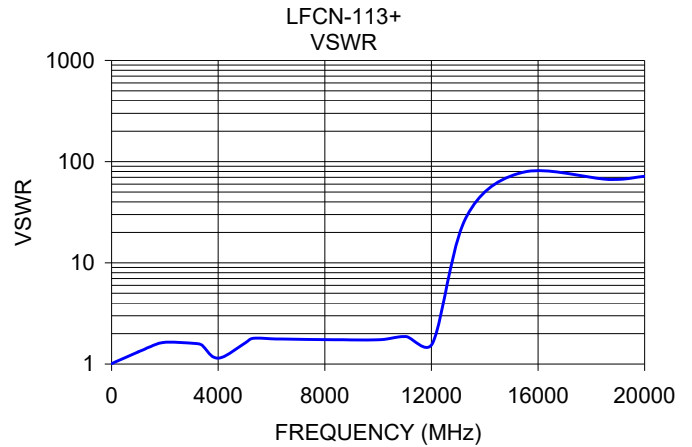
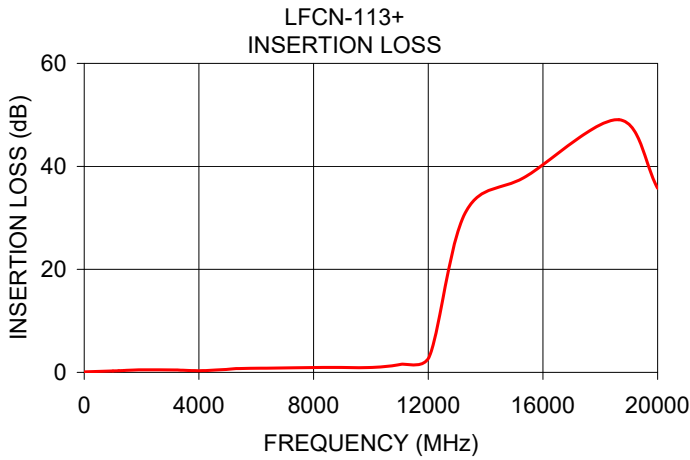

NOTES

- A. Performance and quality attributes and conditions not expressly stated in this specification document are intended to be excluded and do not form a part of this specification document.
- B. Electrical specifications and performance data contained in this specification document are based on Mini-Circuit's applicable established test performance criteria and measurement instructions.
- C. The parts covered by this specification document are subject to Mini-Circuits standard limited warranty and terms and conditions (collectively, "Standard Terms"); Purchasers of this part are entitled to the rights and benefits contained therein. For a full statement of the standard. Terms and the exclusive rights and remedies thereunder, please visit Mini-Circuits' website at www.minicircuits.com/MCLStore/terms.jsp



Typical Performance Data

FREQ. (MHz)	INSERTION LOSS (dB)			INPUT RETURN LOSS (dB)			OUTPUT RETURN LOSS (dB)		
	@ -55°C	@+25°C	@+100°C	@ -55°C	@+25°C	@+100°C	@ -55°C	@+25°C	@+100°C
10.0	0.05	0.06	0.06	68.04	63.39	56.87	62.70	62.92	57.18
50.0	0.06	0.06	0.07	44.91	49.30	54.54	44.65	48.62	51.90
100.0	0.06	0.07	0.08	38.42	40.93	44.97	38.28	40.79	44.28
170.0	0.07	0.09	0.10	34.63	34.99	35.92	34.75	35.19	36.01
280.0	0.08	0.10	0.12	32.40	31.00	29.57	32.38	31.03	29.52
390.0	0.08	0.11	0.14	29.10	27.80	26.12	29.11	27.84	26.12
500.0	0.08	0.12	0.15	25.87	25.34	24.20	26.07	25.54	24.36
1000.0	0.14	0.21	0.26	19.13	18.71	18.02	19.17	18.72	18.05
1210.0	0.17	0.25	0.31	17.06	16.67	16.35	17.10	16.71	16.38
1610.0	0.26	0.35	0.42	14.24	14.19	14.13	14.27	14.24	14.19
2010.0	0.33	0.45	0.52	12.61	12.56	12.62	12.58	12.55	12.65
2810.0	0.40	0.52	0.60	11.73	11.91	12.37	11.54	11.79	12.31
3200.0	0.34	0.48	0.58	12.59	12.83	13.45	12.43	12.78	13.48
3600.0	0.22	0.38	0.50	15.14	15.53	16.30	15.06	15.59	16.60
4000.0	0.10	0.29	0.44	22.24	22.76	23.60	22.55	23.52	25.49
4400.0	0.08	0.28	0.45	27.77	26.42	25.35	28.51	27.34	26.25
4800.0	0.15	0.36	0.52	16.78	17.01	17.60	16.85	17.06	17.62
5000.0	0.22	0.43	0.58	13.96	14.46	15.13	13.92	14.40	15.01
5640.0	0.37	0.59	0.76	11.18	11.62	12.37	11.09	11.53	12.25
5950.0	0.42	0.65	0.82	10.68	11.16	11.95	10.59	11.07	11.80
6260.0	0.38	0.63	0.84	11.48	11.86	12.54	11.41	11.81	12.41
6580.0	0.29	0.56	0.80	13.20	13.63	14.28	13.05	13.48	14.04
6890.0	0.21	0.50	0.75	15.54	16.06	16.80	15.31	15.68	16.19
7200.0	0.13	0.42	0.70	19.84	20.35	20.69	19.80	20.11	20.24
7820.0	0.19	0.50	0.78	19.58	19.63	19.50	20.69	21.04	22.64
8450.0	0.30	0.63	0.92	15.26	15.48	15.97	15.68	16.22	17.74
9070.0	0.38	0.77	1.11	16.07	16.10	16.44	16.75	16.90	17.87
9700.0	0.65	1.06	1.46	19.92	20.87	21.63	22.53	23.74	23.87
9830.0	0.69	0.99	1.39	22.97	26.14	28.40	24.41	27.12	25.29
9940.0	0.63	1.05	1.47	24.72	27.55	31.72	24.80	24.82	24.22
10160.0	0.90	1.16	1.51	25.21	32.74	43.04	22.73	23.62	24.19
10610.0	0.80	1.21	1.64	26.44	23.21	22.42	21.33	20.18	20.50
10840.0	0.81	1.16	1.71	21.55	19.66	18.98	18.30	18.83	19.26
10950.0	0.79	1.19	1.73	19.87	18.30	18.29	17.65	17.52	17.85
11060.0	0.91	1.31	1.74	17.92	16.30	15.89	15.85	15.63	16.28
11280.0	0.96	1.43	1.88	15.18	14.94	14.68	14.09	14.54	15.50
11400.0	1.04	1.50	1.99	14.62	14.44	14.42	13.62	14.06	14.51
11620.0	1.16	1.69	2.18	12.30	12.58	12.93	12.49	13.27	14.01
11830.0	1.36	1.93	2.46	10.60	11.06	11.78	13.10	13.89	14.43
12040.0	1.83	2.54	3.19	8.62	8.73	9.19	12.87	13.30	13.13
12250.0	2.91	3.96	4.85	5.82	5.74	6.00	9.41	8.90	8.37
12460.0	4.99	6.43	7.82	3.35	3.38	3.73	5.49	5.07	5.05
12880.0	12.47	14.45	16.26	0.97	1.37	1.92	1.61	1.87	2.32
13290.0	21.56	23.60	25.62	0.42	0.86	1.37	0.62	1.05	1.51
13920.0	41.17	43.82	45.92	0.17	0.55	0.93	0.21	0.60	0.97
14900.0	35.47	35.85	35.93	0.12	0.25	0.54	0.09	0.30	0.57
15240.0	35.56	35.93	35.99	0.18	0.21	0.55	0.15	0.25	0.53
16930.0	42.55	42.51	42.81	0.22	0.45	1.18	0.08	0.54	1.14
17500.0	49.83	49.81	53.04	0.17	0.41	1.07	0.05	0.54	1.26
18650.0	46.83	44.97	45.47	0.44	0.19	0.93	0.38	0.26	1.00
19800.0	36.91	37.19	36.67	0.52	0.11	0.89	0.30	0.38	1.13
20000.0	34.78	35.22	35.33	0.55	0.14	0.86	0.34	0.42	1.10



Typical Performance Data

FREQ. (MHz)	GROUP DELAY (nsec)		
	@ -55°C	@+25°C	@+100°C
10.0	0.07	0.07	0.07
50.0	0.07	0.07	0.07
100.0	0.07	0.07	0.07
230.0	0.08	0.07	0.05
280.0	0.06	0.05	0.06
340.0	0.06	0.06	0.06
390.0	0.07	0.06	0.06
450.0	0.07	0.06	0.06
500.0	0.06	0.06	0.06
560.0	0.07	0.07	0.07
610.0	0.07	0.07	0.06
670.0	0.07	0.07	0.07
720.0	0.06	0.06	0.05
780.0	0.06	0.06	0.06
830.0	0.07	0.06	0.06
890.0	0.07	0.06	0.06
940.0	0.07	0.07	0.07
1000.0	0.06	0.06	0.05
1210.0	0.06	0.06	0.06
1410.0	0.07	0.06	0.06
1610.0	0.07	0.06	0.06
1810.0	0.05	0.06	0.04
2010.0	0.06	0.06	0.06
2210.0	0.07	0.06	0.06
2410.0	0.06	0.06	0.06
2610.0	0.07	0.06	0.07
2810.0	0.03	0.04	0.05
3010.0	0.06	0.05	0.06
3200.0	0.04	0.06	0.04
3600.0	0.07	0.07	0.07
3800.0	0.08	0.07	0.06
4000.0	0.07	0.07	0.07
4200.0	0.07	0.07	0.06
4600.0	0.08	0.07	0.07
4800.0	0.07	0.07	0.06
5000.0	0.07	0.07	0.06
5020.0	0.07	0.06	0.06
5330.0	0.07	0.07	0.06
5640.0	0.07	0.07	0.07
5950.0	0.07	0.07	0.07
6260.0	0.07	0.07	0.07
6580.0	0.07	0.07	0.05
6890.0	0.08	0.08	0.08
7200.0	0.11	0.10	0.09
7510.0	0.08	0.11	0.09
7820.0	0.10	0.06	0.07
8450.0	0.10	0.10	0.12
8760.0	0.13	0.12	0.15
9070.0	0.11	0.10	0.13
10050.0	0.19	0.12	0.13
10950.0	0.13	0.26	0.15
11060.0	0.10	0.18	0.16

Typical Performance Data

INSERTION LOSS vs. TEMPERATURE

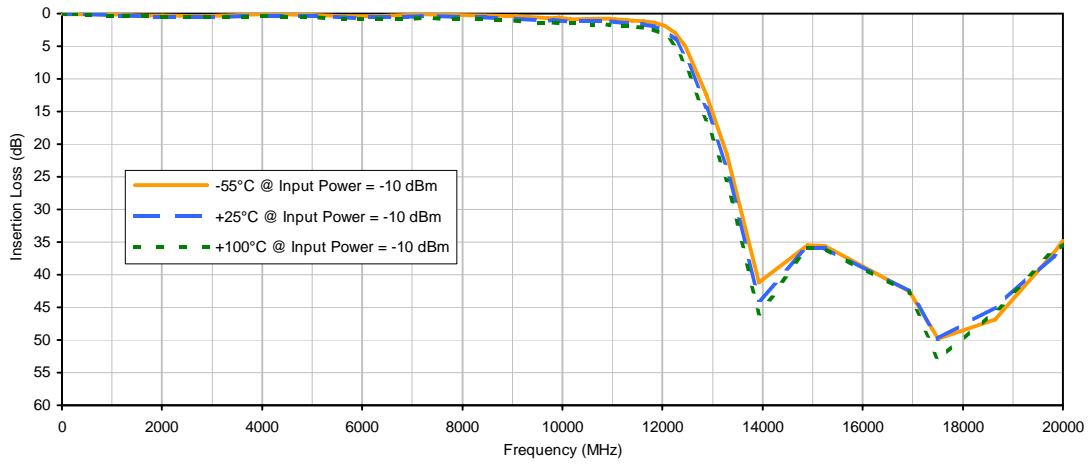

INPUT RETURN LOSS vs. TEMPERATURE

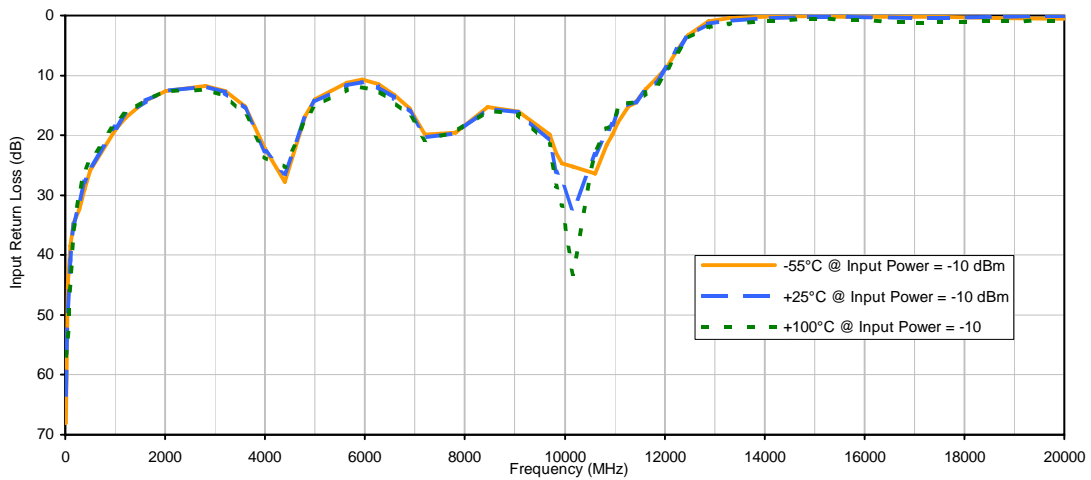

OUTPUT RETURN LOSS vs. TEMPERATURE

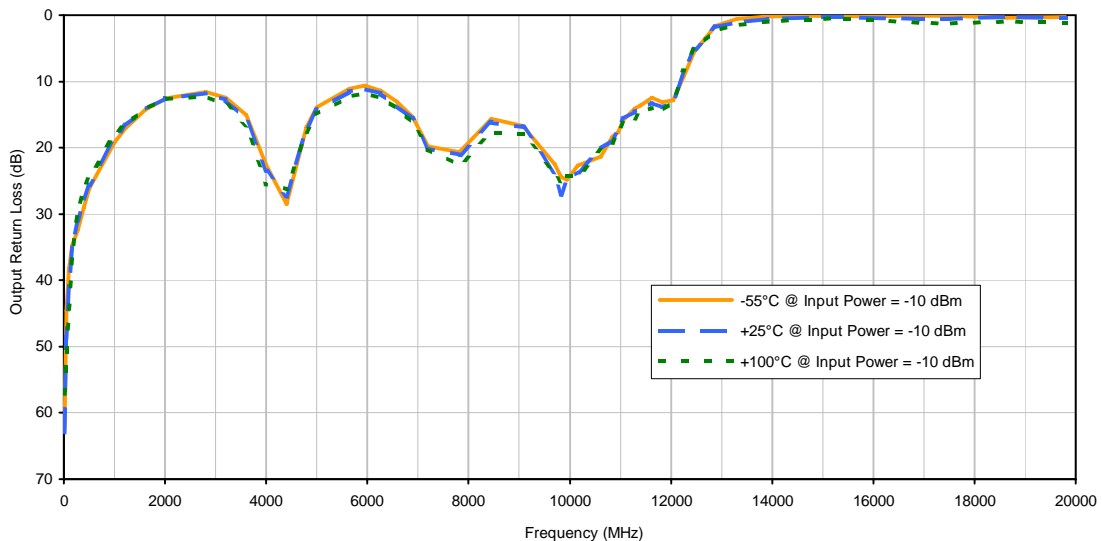

Typical Performance Data

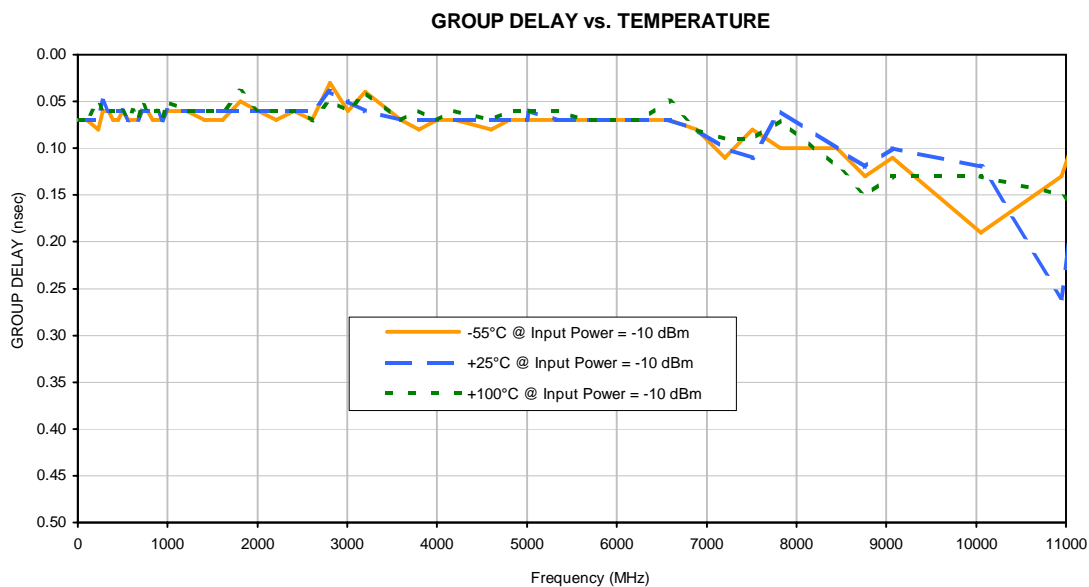

Outline Dimensions

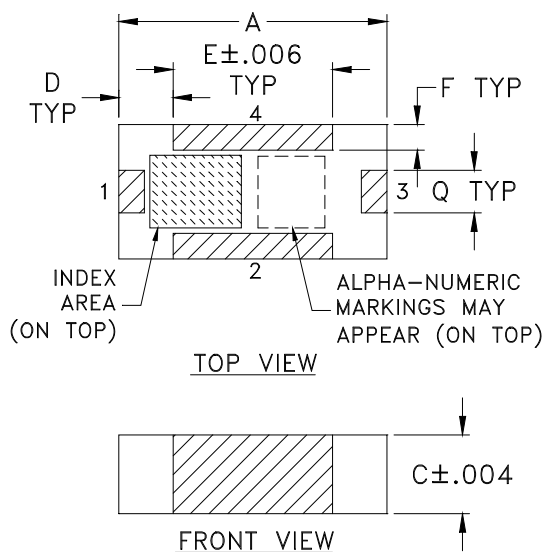

PCB Land Pattern

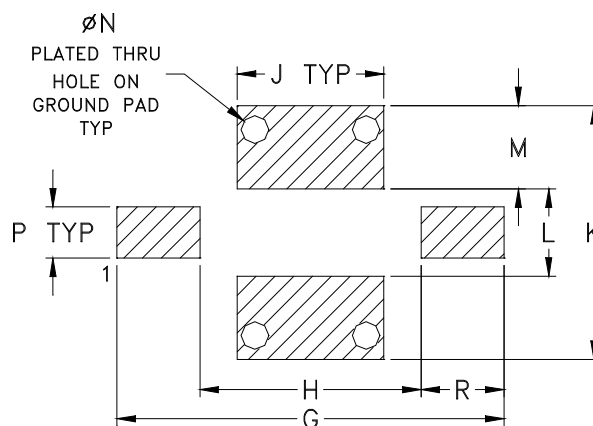

Suggested Layout,
Tolerance to be within ± 0.02

CASE #	A	B	C	D	E	F	G	H	J	K	L	M
FV1206-4	.126 (3.20)	.063 (1.60)	.037 (0.94)	.026 (0.66)	.075 (1.91)	.012 (0.30)	.182 (4.62)	.104 (2.64)	.069 (1.75)	.119 (3.02)	.041 (1.04)	.039 (0.99)

CASE #	N	P	Q	R	WT. GRAM
FV1206-4	.013 (0.33)	.024 (0.61)	.020 (0.51)	.039 (0.99)	.020

Dimensions are in inches (mm). Tolerances: 2 Pl. $\pm .01$; 3 Pl. $\pm .005$

Notes:

- Open style, ceramic base.
- Termination finish: **as shown below or indicated on Data Sheet.**
 For RoHS Case Styles: Tin plate over Nickel plate. All models, (+) suffix.
 For RoHS-5 Case Styles: Tin-Lead plate. All models, no (+) suffix.



P.O. Box 350166, Brooklyn, New York 11235-0003 (718) 934-4500 Fax (718) 332-4661 For detailed performance specs & shopping online see Mini-Circuits web site



The Design Engineers Search Engine Provides ACTUAL Data Instantly From MINI-CIRCUITS At: www.minicircuits.com

RF/IF MICROWAVE COMPONENTS

DEVICE ORIENTATION IN T&R

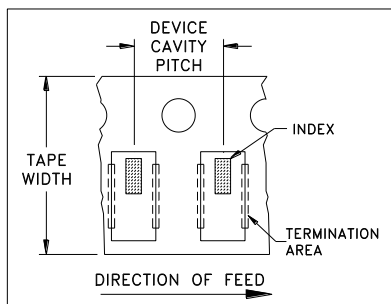

ILLUSTRATION 1

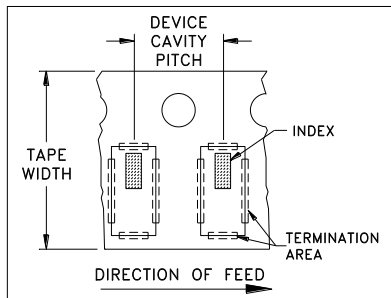

ILLUSTRATION 2

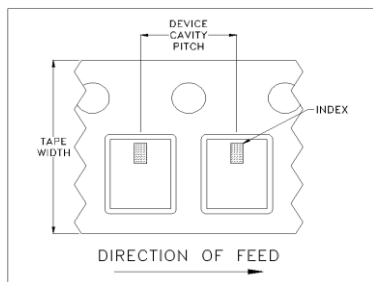

ILLUSTRATION 3

Applicable Case Styles

FV1206-1
FV1206-3

Applicable Case Styles

FV1206-4
FV1206-5
FV1206-6
FV1206-7
FV1206-9

Applicable Case Styles

FV1206-12
GE0805C-18
NL1008C-6
NL1008C-7
NL1008C-9
NL1008C-10

Tape Width, mm	Device Cavity Pitch, mm	Reel Size, inches	Devices per Reel	
8	4	7	Small quantity standards (see note)	20
				50
				100
				200
				500
			1000	
			Standard	3000

Note: Please consult individual model data sheet to determine device per reel availability.

Mini-Circuits carrier tape materials provide protection from ESD (Electro-Static Discharge) during handling and transportation. Tapes are static dissipative and comply with industry standards EIA-481/EIA-541.

Go to: www.minicircuits.com/pages/pdfs/tape.pdf

Mini-Circuits ISO 9001 & ISO 14001 Certified

Mini-Circuits[®]

INTERNET <http://www.minicircuits.com>

P.O. Box 350166, Brooklyn, New York 11235-0003 (718) 934-4500 Fax (718) 332-4661

Distribution Centers NORTH AMERICA 800-654-7949 • 417-335-5935 • Fax 417-335-5945 • EUROPE 44-1252-832600 • Fax 44-1252-837010

Mini-Circuits ISO 9001 & ISO 14001 Certified

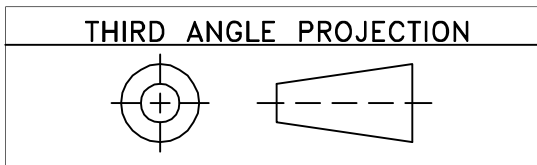

REVISIONS					
REV OR	ECN No.	DESCRIPTION	DATE	DR	AUTH
	M163991	NEW RELEASE	10/03/17	CA	JLM

**SUGGESTED MOUNTING CONFIGURATION FOR
FOR FV1206-4 CASE STYLE, "04FL01" PIN CONNECTION**

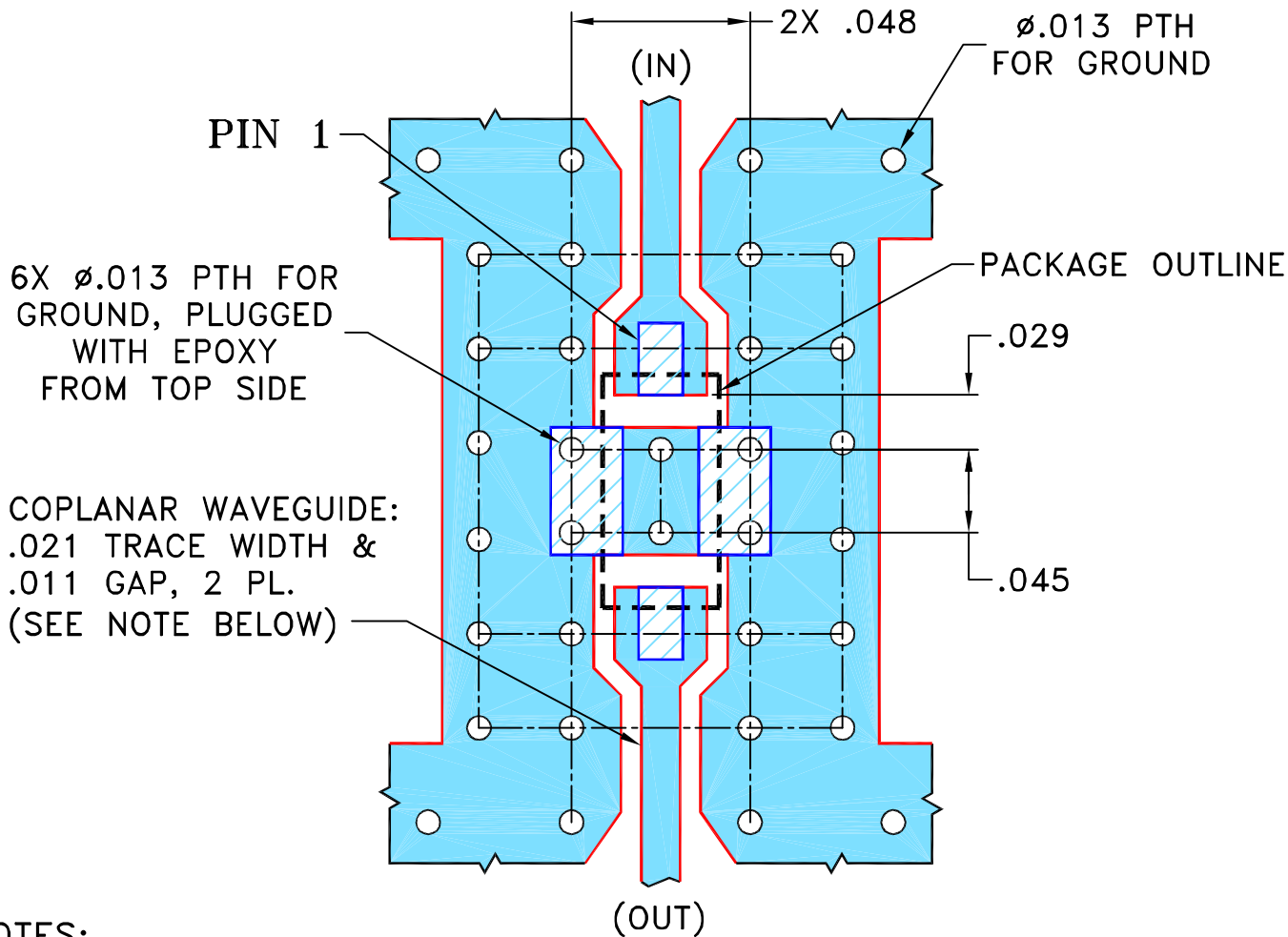

NOTES:

1. TRACE WIDTH & GAP ARE SHOWN FOR ROGERS RO4350B WITH DIELECTRIC THICKNESS .010" ± .001"; COPPER: 1/2 OZ. EACH SIDE. FOR OTHER MATERIALS TRACE WIDTH MAY NEED TO BE MODIFIED.
2. BOTTOM SIDE OF THE PCB IS CONTINUOUS GROUND PLANE.



DENOTES PCB COPPER LAYOUT WITH SMOBC (SOLDER MASK OVER BARE COPPER)



DENOTES COPPER LAND PATTERN FREE OF SOLDER MASK

UNLESS OTHERWISE SPECIFIED	INITIALS	DATE
DIMENSIONS ARE IN INCHES	DRAWN CA	09/27/17
TOLERANCES ON:	CHECKED GF	10/03/17
2 PL DECIMALS ±	APPROVED JLM	10/03/17
3 PL DECIMALS ± .005		
ANGLES ±		
FRACTIONS ±		



Mini-Circuits®

13 Neptune Avenue
Brooklyn NY 11235

PL, 04FL01, FV1206-4, TB-637+

Mini-Circuits®
THIS DOCUMENT AND ITS CONTENTS ARE THE PROPERTY OF MINI-CIRCUITS. EXCEPT FOR USE EXPRESSLY GRANTED, IN WRITING, TO ITS VENDORS, VENDEE AND THE UNITED STATES GOVERNMENT, MINI-CIRCUITS RESERVES ALL PROPRIETARY DESIGN, USE, MANUFACTURING AND REPRODUCTION RIGHTS THERETO. THESE CONTENTS SHALL NOT BE USED, DUPLICATED OR DISCLOSED TO ANY OUTSIDE PARTY, IN WHOLE OR IN PART, WITHOUT WRITTEN PERMISSION OF MINI-CIRCUITS.

ASHEETA1.DWG REV:A DATE:01/12/95

SIZE	CODE IDENT	DRAWING NO:	REV:
A	15542	98-PL-530	OR
FILE:	98PL530	SCALE: 10:1	SHEET: 1 OF 1

Evaluation Board and Circuit

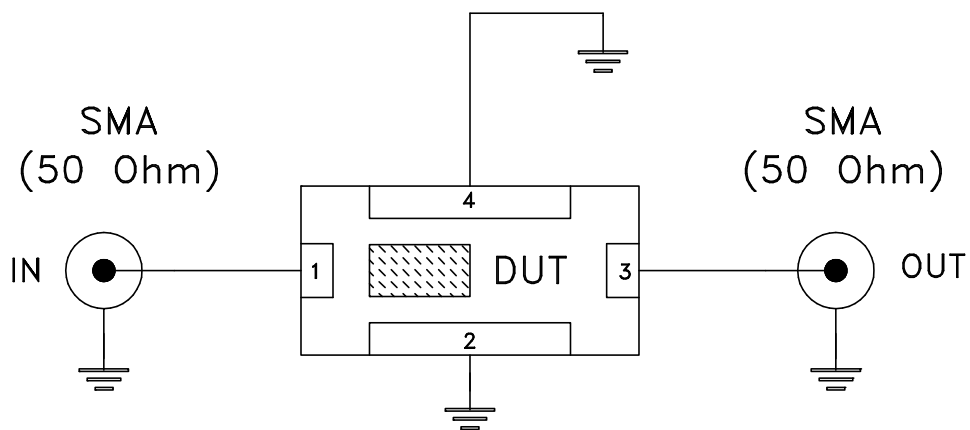
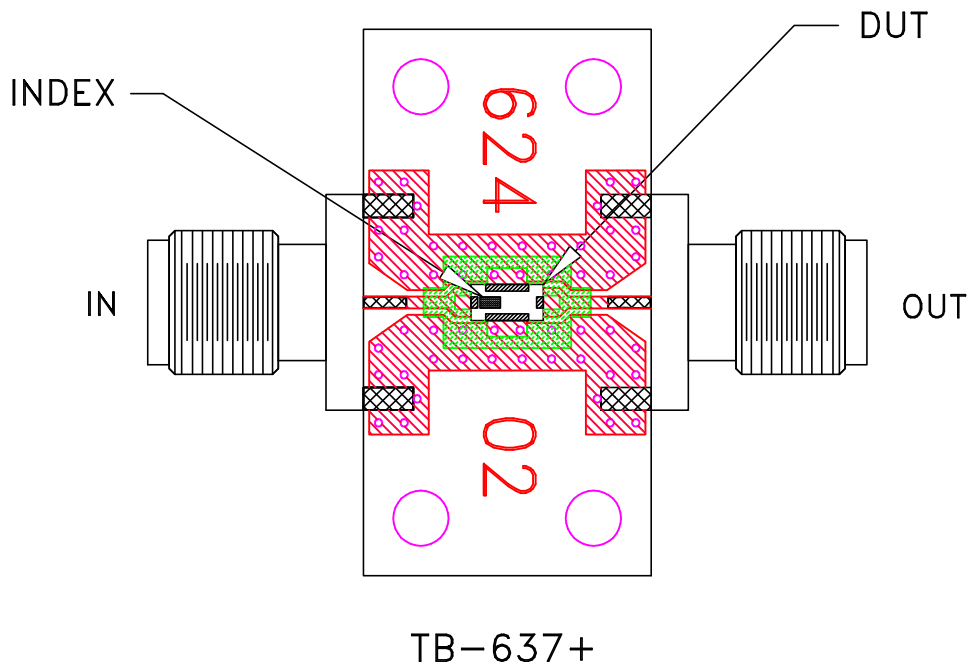

Schematic Diagram

Notes:

1. 50 Ohm SMA Female connectors.
2. PCB Material: R04350 or equivalent,
Dielectric Constant=3.5, Thickness=.010 inch.

 **Mini-Circuits®**

All Mini-Circuits products are manufactured under exacting quality assurance and control standards, and are capable of meeting published specifications after being subjected to any or all of the following physical and environmental test.

Specification	Test/Inspection Condition	Reference/Spec
Operating Temperature	-55° to 100°C Ambient Environment	Individual Model Data Sheet
Storage Temperature	-55° to 100° C Ambient Environment	Individual Model Data Sheet
Humidity	90 to 95% RH, 240 hours, 50°C	MIL-STD-202, Method 103, Condition A, Except 50°C and end-point electrical test done within 12 hours
Solder Reflow Heat	Sn-Pb Eutetic Process: 225°C peak Pb-Free Process 245° - 250°C peak	J-STD-020, Table 4-1, 4-2 and 5-2, Figure 5-1
Solderability	10X Magnification	J-STD-002, Para 4.2.5, Test S, 95% Coverage
Vibration (High Frequency)	20g peak, 10-2000 Hz, 12 times in each of three perpendicular directions (total 36)	MIL-STD-202, Method 204, Condition D
Mechanical Shock	50g, 11 ms, 1/2-sine, 18 shocks: 3 each direction, each of 3 axes	MIL-STD-202, Method 213, Condition A