

High IP3 Frequency Mixer

LAVI-10VH+

Level 21 (LO Power +21 dBm) 300 to 1000 MHz



Generic photo used for illustration purposes only
CASE STYLE: CK605

+RoHS Compliant

The +Suffix identifies RoHS Compliance. See our web site for RoHS Compliance methodologies and qualifications

Maximum Ratings

Operating Temperature	-45°C to 85°C
Storage Temperature	-55°C to 100°C
LO Power	+24 dBm
RF Power	+23 dBm

Permanent damage may occur if any of these limits are exceeded.

Pin Connections

LO	10
RF	2
IF	14
GROUND	1,3,4,5,6,7,8,9,11,12,13,15,16

Features

- very high IP3, 33 dBm typ.
- wideband, 300 to 1000 MHz
- excellent L-R isolation, 50 dB typ. and L-I isolation, 45 dB typ.
- high 1 dB compression, 20 dBm typ.
- shielded metal cover
- aqueous washable
- protected by US Patent 6,807,407

Applications

- cellular base stations
- mobile radio
- defense communications

Electrical Specifications (T_{AMB} = 25°C)

FREQUENCY (MHz)			CONVERSION LOSS (dB)			RF in at 1dB Compr (dBm)	IP3 (dBm)	LO-RF ISOLATION (dB)		LO-IF ISOLATION (dB)	
RF	LO	IF	Typ.	σ	Max.	Typ.	Typ.	Typ.	Min.	Typ.	Min.
300-1000	525-1175	60-875	6.3	0.12	8.0	+20	33	50	40	45	30

Typical Performance Data

Frequency (MHz)		Conversion Loss (dB)	Isolation L-R (dB)	Isolation L-I (dB)	VSWR RF Port (:1)	VSWR LO Port (:1)	IP3 (dBm)	IF Freq. (MHz)	VSWR IF (:1)
RF	LO	LO +21dBm	LO +21dBm	LO +21dBm	LO +21dBm	LO +21dBm	LO +21dBm	LO +21dBm	LO +21dBm
300.10	475.00	6.01	61.98	47.09	1.53	8.60	32.29	60.00	2.37
350.10	525.00	6.17	57.30	46.07	1.51	5.97	32.63	80.00	2.20
400.10	575.00	6.05	53.79	45.57	1.59	6.81	33.47	100.00	2.07
500.10	675.00	6.14	50.76	46.77	1.55	4.32	33.65	120.00	2.03
550.10	725.00	6.16	50.36	47.01	1.59	3.34	32.76	160.00	1.92
600.10	775.00	6.16	49.84	48.36	1.68	3.11	33.04	180.00	1.87
650.10	825.00	6.15	49.66	51.05	1.72	2.25	33.60	200.00	1.85
700.10	875.00	6.18	49.50	52.92	1.80	2.31	34.34	250.00	1.70
750.10	925.00	6.13	50.01	53.20	1.82	1.72	34.02	300.00	1.56
800.10	975.00	6.24	51.54	53.64	1.88	1.93	34.09	400.00	1.31
850.10	1025.00	6.18	53.99	54.13	1.89	1.94	34.21	500.00	1.28
870.10	1070.00	6.38	58.36	56.30	1.92	2.46	33.47	600.00	1.58
900.10	1070.00	6.39	58.36	56.30	1.93	2.46	33.87	700.00	1.94
950.10	1125.00	6.34	62.49	59.25	1.95	3.38	33.64	800.00	2.16
1000.10	1175.00	6.56	62.18	62.18	1.94	3.52	32.46	900.00	2.34

Outline Drawing

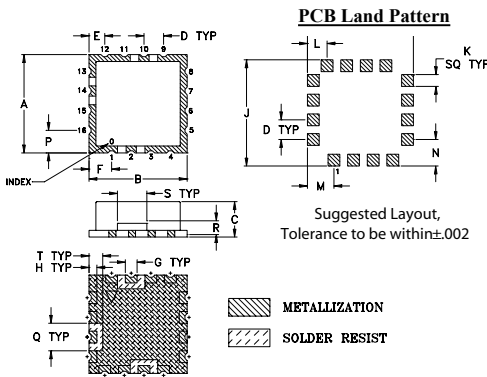

Outline Dimensions (inch/mm)

A	B	C	D	E	F	G	H	J	K
.500	.500	.180	.100	.080	.115	.060	.040	.540	.060
12.7	12.7	4.572	2.54	2.032	2.921	1.524	1.016	13.72	1.524
L	M	N	P	Q	R	S	T	wt.	
.100	.135	.135	.115	.140	.070	.150	.070	grams	
2.54	3.429	3.429	2.921	3.556	1.778	3.81	1.778	1.0	

Demo Board MCL P/N: TB-433+ Suggested PCB Layout (PL-012)

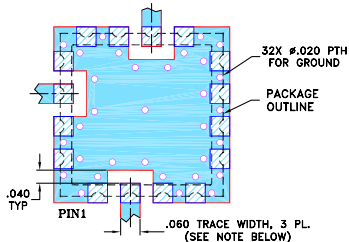

- NOTES: 1. TRACE WIDTH IS SHOWN FOR FR4 WITH DIELECTRIC THICKNESS .030" ± .002"; COPPER: 1/2 OZ. EACH SIDE. FOR OTHER MATERIALS TRACE WIDTH MAY NEED TO BE MODIFIED.
2. BOTTOM SIDE OF THE PCB IS CONTINUOUS GROUND PLANE.
- DENOTES PCB COPPER LAYOUT WITH SMOBC (SOLDER MASK OVER BARE COPPER)
- DENOTES COPPER LAND PATTERN FREE OF SOLDER MASK

Electrical Schematic

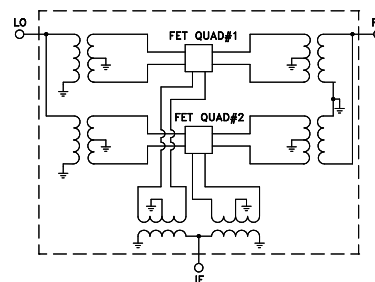

Notes

- A. Performance and quality attributes and conditions not expressly stated in this specification document are intended to be excluded and do not form a part of this specification document.
- B. Electrical specifications and performance data contained in this specification document are based on Mini-Circuits' applicable established test performance criteria and measurement instructions.
- C. The parts covered by this specification document are subject to Mini-Circuits standard limited warranty and terms and conditions (collectively, "Standard Terms"); Purchasers of this part are entitled to the rights and benefits contained therein. For a full statement of the Standard Terms and the exclusive rights and remedies thereunder, please visit Mini-Circuits' website at www.minicircuits.com/MCLStore/terms.jsp



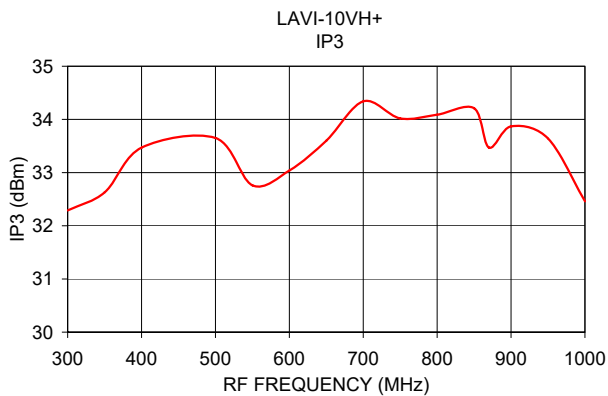
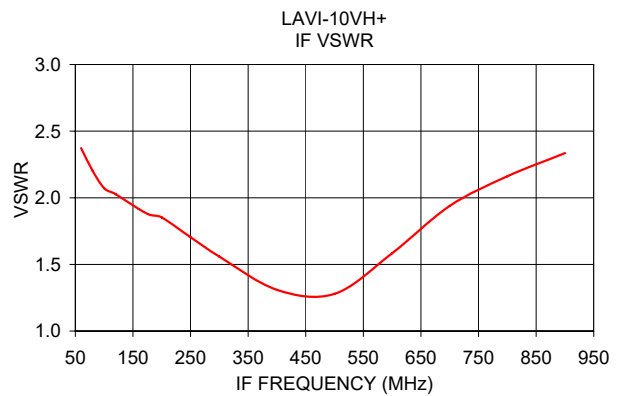
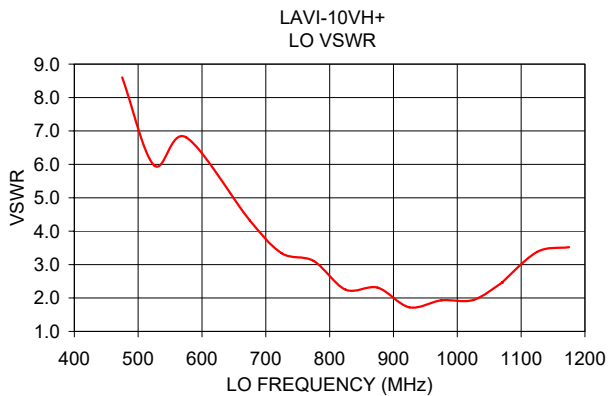
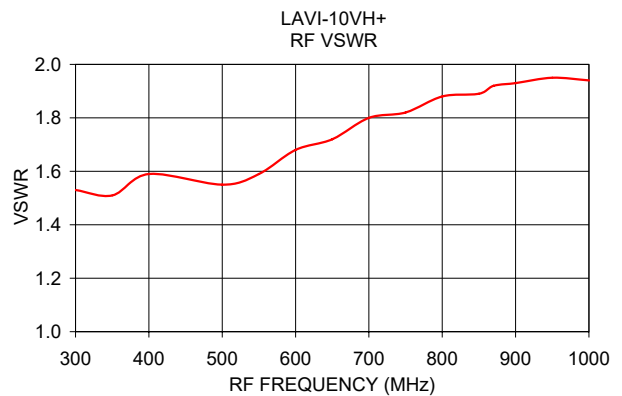
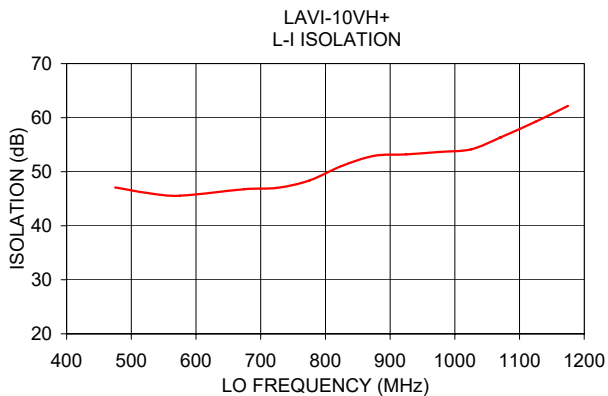
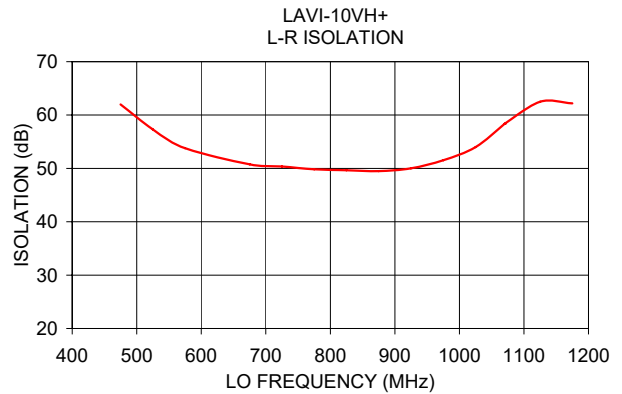
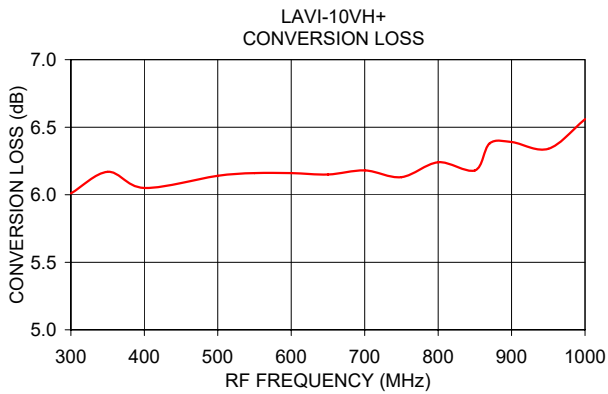

Notes

- A. Performance and quality attributes and conditions not expressly stated in this specification document are intended to be excluded and do not form a part of this specification document.
- B. Electrical specifications and performance data contained in this specification document are based on Mini-Circuit's applicable established test performance criteria and measurement instructions.
- C. The parts covered by this specification document are subject to Mini-Circuits standard limited warranty and terms and conditions (collectively, "Standard Terms"); Purchasers of this part are entitled to the rights and benefits contained therein. For a full statement of the Standard Terms and the exclusive rights and remedies thereunder, please visit Mini-Circuits' website at www.minicircuits.com/MCLStore/terms.jsp



Harmonic Table ($T_{AMB} = 25^{\circ}\text{C}$) (Relative to desired IF output)

RF HARMONICS ORDER	RF CAL (-dBc)											
	0	1	2	3	4	5	6	7	8	9	10	
0	-	-	13	23	20	33	21	34	29	43	38	52
1	-	32	0	37	14	40	26	56	42	55	54	60
2	88	60	71	55	64	58	73	60	66	66	72	78
3	96	95	72	90	70	91	72	96	76	92	80	102
4	100	105	95	100	96	103	100	106	101	106	106	107
5	97	105	104	101	104	96	100	102	103	104	104	107
6	100	106	105	107	100	101	98	103	102	105	105	107
7	100	109	109	104	104	100	101	98	101	105	105	108
8	100	109	108	108	105	103	98	100	100	99	106	105
9	101	108	108	106	105	106	102	104	100	104	102	107
10	101	107	108	110	107	106	107	100	102	99	104	103

Test conditions: RF IN: 650 MHz, 0 dBm.
 LO IN: 822.5 MHz, 21 dBm.
 IF OUT: 172.5 MHz
 C. LOSS: 6.36 dB.

Notes

- A. Performance and quality attributes and conditions not expressly stated in this specification document are intended to be excluded and do not form a part of this specification document.
- B. Electrical specifications and performance data contained in this specification document are based on Mini-Circuit's applicable established test performance criteria and measurement instructions.
- C. The parts covered by this specification document are subject to Mini-Circuits standard limited warranty and terms and conditions (collectively, "Standard Terms"); Purchasers of this part are entitled to the rights and benefits contained therein. For a full statement of the Standard Terms and the exclusive rights and remedies thereunder, please visit Mini-Circuits' website at www.minicircuits.com/MCLStore/terms.jsp



Frequency Mixer

LAVI-10VH+

Typical Performance Data

RF (IN) (MHz)	LO (MHz)	CONVERSION LOSS IF FIXED @IF(OUT)=175MHz (dB)			RF (IN) (MHz)	LO (MHz)	IP3 INPUT (dBm)		
		@LO (dBm)					@LO (dBm)		
		+18	+21	+24			+18	+21	+24
10.1	185.1	6.35	6.06	5.87	10.1	185.1	19.46	22.97	26.51
70.3	245.3	6.31	6.14	6.03	70.3	245.3	23.89	27.26	29.17
130.6	305.6	6.21	6.07	5.97	130.6	305.6	27.62	30.12	32.33
190.8	365.8	6.38	6.30	6.43	190.8	365.8	29.52	31.22	26.35
251.0	426.0	6.36	6.28	6.23	251.0	426.0	30.32	33.01	35.98
311.3	486.3	6.44	6.36	6.30	311.3	486.3	29.92	32.09	34.02
371.5	546.5	6.50	6.42	6.38	371.5	546.5	30.95	34.64	38.63
431.7	606.7	6.44	6.35	6.29	431.7	606.7	29.94	32.61	34.61
492.0	667.0	6.45	6.34	6.26	492.0	667.0	30.89	34.00	36.33
552.2	727.2	6.48	6.37	6.29	552.2	727.2	30.42	33.52	36.53
612.4	787.4	6.40	6.29	6.20	612.4	787.4	29.88	32.56	34.78
672.7	847.7	6.48	6.35	6.25	672.7	847.7	30.50	34.03	38.21
732.9	907.9	6.54	6.40	6.32	732.9	907.9	29.64	32.22	34.25
793.1	968.1	6.64	6.49	6.39	793.1	968.1	30.95	35.30	39.80
853.4	1028.4	6.84	6.72	6.62	853.4	1028.4	30.08	33.23	36.51
913.6	1088.6	7.00	6.89	6.80	913.6	1088.6	29.35	32.27	35.39
993.9	1168.9	7.23	7.12	7.04	993.9	1168.9	28.84	32.77	37.16
1054.1	1229.1	7.35	7.25	7.18	1054.1	1229.1	28.41	31.50	34.98
1134.4	1309.4	7.50	7.39	7.33	1134.4	1309.4	27.94	31.53	36.17
1194.7	1369.7	7.68	7.56	7.49	1194.7	1369.7	26.98	30.00	33.37
1275.0	1450.0	7.93	7.78	7.68	1275.0	1450.0	26.17	28.86	32.34
1335.2	1510.2	8.02	7.84	7.74	1335.2	1510.2	25.50	28.15	31.45
1415.5	1590.5	8.22	8.02	7.90	1415.5	1590.5	24.85	27.41	30.17
1475.8	1650.8	8.40	8.17	8.03	1475.8	1650.8	24.08	26.40	28.92
1556.1	1731.1	8.60	8.33	8.14	1556.1	1731.1	23.00	25.68	28.07
1616.3	1791.3	8.68	8.38	8.16	1616.3	1791.3	22.13	24.99	27.86
1696.6	1871.6	8.86	8.49	8.24	1696.6	1871.6	21.19	24.29	27.35
1756.8	1931.8	9.05	8.65	8.38	1756.8	1931.8	20.60	23.74	27.07
1837.2	2012.2	9.28	8.83	8.51	1837.2	2012.2	19.82	22.89	26.18
1897.4	2072.4	9.38	8.89	8.53	1897.4	2072.4	19.16	22.05	25.43
1977.7	2152.7	9.51	8.96	8.56	1977.7	2152.7	18.57	21.49	24.77
2037.9	2212.9	9.67	9.09	8.67	2037.9	2212.9	18.45	21.33	24.71
2118.2	2293.2	9.92	9.24	8.81	2118.2	2293.2	17.77	20.71	23.82
2178.5	2353.5	9.97	9.24	8.77	2178.5	2353.5	17.30	20.12	23.13
2258.8	2433.8	10.02	9.28	8.80	2258.8	2433.8	17.14	19.89	22.93
2319.0	2494.0	10.21	9.50	8.98	2319.0	2494.0	17.11	19.62	22.72
2399.3	2574.3	10.53	9.75	9.20	2399.3	2574.3	16.62	18.95	21.98
2459.6	2634.6	10.64	9.85	9.30	2459.6	2634.6	16.59	18.79	21.79
2539.9	2714.9	11.18	10.36	9.89	2539.9	2714.9	16.75	19.09	21.92
2600.1	2775.1	11.98	11.23	10.88	2600.1	2775.1	17.03	19.43	21.97

Frequency Mixer

LAVI-10VH+

Typical Performance Data

IF (OUT) (MHz)	LO (MHz)	CONVERSION LOSS VS. IF FREQUENCY @RF(IN)=650MHz (dB)	IF (OUT) (MHz)	LO (MHz)	CONVERSION LOSS VS. IF FREQUENCY @RF(IN)=300MHz (dB)	IF (OUT) (MHz)	LO (MHz)	CONVERSION LOSS VS. IF FREQUENCY @RF(IN)=1000.1MHz (dB)
		@LO (dBm)			@LO (dBm)			@LO (dBm)
		+21			+21			+21
629.9	20.1	13.15	10.1	310.1	13.80	980.0	20.1	13.69
598.4	51.6	8.84	50.3	350.3	6.87	960.2	39.9	9.99
566.9	83.1	8.01	90.5	390.5	6.41	940.4	59.7	9.27
535.3	114.7	7.35	130.7	430.7	6.34	920.6	79.5	8.86
503.8	146.2	7.11	171.0	471.0	6.32	900.8	99.3	8.36
472.3	177.7	6.96	211.2	511.2	6.37	881.0	119.1	8.01
440.8	209.2	6.72	251.4	551.4	6.35	861.2	138.9	7.83
409.3	240.7	6.74	291.6	591.6	6.47	841.4	158.7	7.75
377.7	272.3	6.67	331.8	631.8	6.53	821.6	178.5	7.58
346.2	303.8	6.55	392.1	692.1	6.62	801.8	198.3	7.30
314.7	335.3	6.44	432.3	732.3	6.54	782.0	218.1	7.21
283.2	366.8	6.38	492.7	792.7	6.41	762.2	237.9	7.14
251.7	398.3	6.31	532.9	832.9	6.36	742.4	257.7	7.11
220.1	429.9	6.28	593.2	893.2	6.42	722.7	277.4	7.02
188.6	461.4	6.33	633.4	933.4	6.49	702.9	297.2	6.99
157.1	492.9	6.34	693.7	993.7	6.49	683.1	317.0	6.93
125.6	524.4	6.37	733.9	1033.9	6.53	663.3	336.8	6.74
94.1	555.9	6.46	794.2	1094.2	6.62	643.5	356.6	6.91
62.5	587.5	6.70	834.5	1134.5	6.77	623.7	376.4	6.91
31.0	619.0	7.94	894.8	1194.8	6.87	603.9	396.2	6.88
10.0	660.0	13.77	935.0	1235.0	6.93	564.3	435.8	6.79
98.5	748.5	6.49	995.3	1295.3	6.96	544.5	455.6	6.74
187.0	837.0	6.33	1035.5	1335.5	7.08	504.9	495.2	6.70
275.4	925.4	6.33	1095.8	1395.8	7.30	485.1	515.0	6.70
363.9	1013.9	6.47	1136.1	1436.1	7.43	445.5	554.6	6.65
452.4	1102.4	6.54	1196.4	1496.4	7.47	425.7	574.4	6.71
540.9	1190.9	6.67	1236.6	1536.6	7.52	386.1	614.0	6.76
629.4	1279.4	6.88	1296.9	1596.9	7.60	366.3	633.8	6.72
717.8	1367.8	6.96	1337.1	1637.1	7.75	326.7	673.4	6.73
806.3	1456.3	7.18	1397.4	1697.4	7.86	306.9	693.2	6.69
894.8	1544.8	7.45	1437.7	1737.7	8.02	267.3	732.8	6.69
983.3	1633.3	7.59	1498.0	1798.0	8.25	247.6	752.5	6.75
1071.8	1721.8	7.88	1538.2	1838.2	8.50	208.0	792.1	6.81
1160.2	1810.2	8.12	1598.5	1898.5	8.78	188.2	811.9	6.86
1248.7	1898.7	8.29	1638.7	1938.7	8.95	148.6	851.5	6.93
1337.2	1987.2	8.64	1699.0	1999.0	9.26	128.8	871.3	6.96
1455.2	2105.2	9.04	1739.2	2039.2	9.58	89.2	910.9	7.25
1543.6	2193.6	9.57	1799.6	2099.6	10.10	69.4	930.7	7.45
1661.6	2311.6	10.05	1839.8	2139.8	10.31	29.8	970.3	8.67
1750.1	2400.1	10.68	1900.1	2200.1	10.55	10.0	990.1	13.97

Frequency Mixer

LAVI-10VH+

Typical Performance Data

LO (MHz)	LO-RF ISOLATION (dB)			LO-IF ISOLATION (dB)			RF (IN) (MHz)	LO (MHz)	RF-IF ISOLATION (dB)		
	@LO (dBm)			@LO (dBm)					@LO (dBm)		
	+18	+21	+24	+18	+21	+24			+18	+21	+24
185.1	50.33	50.56	50.57	46.87	46.98	46.93	10.1	185.1	45.63	47.90	50.53
245.3	48.08	48.40	48.40	44.42	44.46	44.58	70.3	245.3	41.88	44.12	44.63
305.6	48.76	48.84	48.97	44.65	44.63	44.76	130.6	305.6	47.32	47.38	34.35
365.8	50.91	51.32	50.47	46.27	46.47	48.68	190.8	365.8	39.73	38.15	29.10
426.0	55.89	56.59	57.01	49.12	48.62	48.21	251.0	426.0	42.65	40.12	36.39
486.3	67.09	70.76	69.97	48.26	47.68	46.99	311.3	486.3	43.43	42.15	39.63
546.5	56.54	56.32	56.30	46.59	45.95	45.66	371.5	546.5	41.72	41.50	40.79
606.7	52.45	52.28	51.72	46.89	46.69	46.48	431.7	606.7	39.59	38.85	36.06
667.0	50.62	50.72	50.54	46.81	46.90	46.70	492.0	667.0	39.21	38.45	35.65
727.2	49.34	49.47	49.29	47.25	47.31	46.97	552.2	727.2	38.08	38.57	38.72
787.4	47.98	48.23	48.20	48.50	48.84	48.77	612.4	787.4	37.77	38.11	38.74
847.7	47.63	47.93	48.09	51.63	52.92	53.96	672.7	847.7	37.99	38.43	39.12
907.9	47.98	48.29	48.88	53.70	54.17	54.11	732.9	907.9	38.64	39.15	39.84
968.1	48.82	49.16	49.69	46.28	46.36	46.65	793.1	968.1	39.44	40.12	41.24
1028.4	48.34	49.01	49.33	44.48	44.78	44.90	853.4	1028.4	39.64	40.22	41.43
1088.6	47.83	48.45	48.77	44.25	44.55	44.68	913.6	1088.6	39.27	39.83	41.04
1168.9	47.18	47.47	47.33	45.39	45.71	45.78	993.9	1168.9	38.51	39.26	41.14
1229.1	48.07	48.38	48.23	46.49	46.91	46.98	1054.1	1229.1	37.08	37.35	37.88
1309.4	50.17	50.14	48.78	43.57	43.55	43.48	1134.4	1309.4	36.19	36.57	38.67
1369.7	50.33	50.54	50.67	40.14	40.00	40.06	1194.7	1369.7	35.18	35.40	35.79
1450.0	53.63	53.75	51.94	39.31	39.22	39.26	1275.0	1450.0	34.23	34.34	34.30
1510.2	51.74	52.11	52.20	37.31	37.14	36.93	1335.2	1510.2	33.61	33.75	33.96
1590.5	49.54	50.21	50.73	35.93	35.64	35.41	1415.5	1590.5	34.03	33.67	33.26
1650.8	47.45	47.99	48.29	34.92	34.58	34.08	1475.8	1650.8	31.67	31.28	29.89
1731.1	44.70	44.93	45.23	33.52	33.16	32.99	1556.1	1731.1	30.78	30.54	30.39
1791.3	42.87	43.06	42.93	32.45	32.33	31.94	1616.3	1791.3	30.12	29.80	29.35
1871.6	41.37	41.46	41.30	31.57	31.45	31.14	1696.6	1871.6	29.92	29.84	29.66
1931.8	40.41	40.51	40.19	31.03	31.04	30.69	1756.8	1931.8	29.84	29.90	29.95
2012.2	39.60	39.32	39.04	30.61	30.38	30.08	1837.2	2012.2	29.86	29.94	29.93
2072.4	38.78	38.71	38.78	30.09	30.05	29.87	1897.4	2072.4	29.81	29.89	29.97
2152.7	38.02	37.84	37.71	29.58	29.57	29.34	1977.7	2152.7	29.52	29.50	29.60
2212.9	37.77	37.52	37.45	29.37	29.36	29.14	2037.9	2212.9	29.93	29.94	30.09
2293.2	37.68	37.48	36.84	29.22	29.24	29.02	2118.2	2293.2	30.11	30.06	30.10
2353.5	37.91	37.56	37.36	29.21	29.05	29.03	2178.5	2353.5	30.39	30.38	30.38
2433.8	37.81	37.41	37.38	29.37	29.19	29.22	2258.8	2433.8	31.00	31.05	31.05
2494.0	37.39	36.98	36.55	29.57	29.44	29.21	2319.0	2494.0	31.42	31.44	31.41
2574.3	36.58	36.30	35.13	29.81	29.95	29.88	2399.3	2574.3	31.25	31.30	31.26
2634.6	36.28	36.06	35.42	30.06	30.23	30.16	2459.6	2634.6	30.94	30.83	30.62
2714.9	35.82	35.66	35.12	30.83	31.03	30.91	2539.9	2714.9	30.50	30.19	29.89
2775.1	35.26	34.88	33.49	31.48	31.56	31.64	2600.1	2775.1	30.44	30.03	29.40

Frequency Mixer

LAVI-10VH+

Typical Performance Data

RF (IN) (MHz)	LO (MHz)	RF VSWR (:1)			LO (MHz)	LO VSWR (:1)			IF (OUT) (MHz)	IF VSWR @LO=1175MHz (:1)		
		@LO (dBm)				@LO (dBm)				@LO (dBm)		
		+18	+21	+24		+18	+21	+24		+18	+21	+24
10.1	185.1	1.10	1.07	1.11	185.1	4.75	4.75	4.75	10.0	10.69	10.37	10.19
70.3	245.3	1.19	1.24	1.28	245.3	5.61	5.61	5.59	29.9	3.33	3.31	3.31
130.6	305.6	1.31	1.36	1.40	305.6	6.81	6.78	6.76	69.7	1.86	1.92	1.99
190.8	365.8	1.39	1.44	1.50	365.8	7.80	7.76	7.34	89.7	1.70	1.78	1.86
251.0	426.0	1.43	1.47	1.51	426.0	7.90	7.87	7.76	129.5	1.55	1.65	1.73
311.3	486.3	1.44	1.47	1.51	486.3	7.17	7.14	7.08	149.4	1.49	1.59	1.68
371.5	546.5	1.43	1.46	1.49	546.5	6.17	6.13	6.09	189.2	1.46	1.55	1.64
431.7	606.7	1.42	1.43	1.45	606.7	5.27	5.23	5.19	209.1	1.43	1.53	1.61
492.0	667.0	1.48	1.48	1.48	667.0	4.54	4.53	4.52	249.0	1.40	1.49	1.57
552.2	727.2	1.58	1.56	1.55	727.2	3.95	3.93	3.91	268.9	1.38	1.46	1.54
612.4	787.4	1.68	1.65	1.63	787.4	3.45	3.43	3.42	308.7	1.37	1.44	1.51
672.7	847.7	1.81	1.77	1.73	847.7	3.02	3.01	3.01	328.6	1.33	1.40	1.47
732.9	907.9	1.94	1.89	1.86	907.9	2.62	2.61	2.61	368.4	1.36	1.41	1.47
793.1	968.1	2.10	2.04	2.00	968.1	2.30	2.30	2.29	388.4	1.34	1.39	1.44
853.4	1028.4	2.22	2.16	2.11	1028.4	2.07	2.07	2.08	428.2	1.30	1.33	1.37
913.6	1088.6	2.31	2.26	2.21	1088.6	1.95	1.96	1.98	448.1	1.31	1.34	1.37
993.9	1168.9	2.36	2.31	2.26	1168.9	2.10	2.13	2.15	487.9	1.26	1.28	1.30
1054.1	1229.1	2.33	2.27	2.23	1229.1	2.49	2.52	2.55	507.8	1.27	1.27	1.29
1134.4	1309.4	2.30	2.23	2.18	1309.4	3.35	3.40	3.43	547.7	1.28	1.27	1.27
1194.7	1369.7	2.28	2.20	2.15	1369.7	4.20	4.26	4.32	567.6	1.26	1.24	1.23
1275.0	1450.0	2.22	2.14	2.07	1450.0	5.31	5.36	5.41	607.4	1.28	1.23	1.21
1335.2	1510.2	2.16	2.07	2.01	1510.2	5.87	5.85	5.70	627.3	1.31	1.26	1.23
1415.5	1590.5	2.07	1.97	1.91	1590.5	6.28	6.21	5.99	667.2	1.27	1.21	1.17
1475.8	1650.8	2.02	1.92	1.85	1650.8	6.39	6.37	6.28	687.1	1.30	1.23	1.18
1556.1	1731.1	1.95	1.85	1.77	1731.1	6.19	6.15	6.03	726.9	1.33	1.25	1.20
1616.3	1791.3	1.91	1.81	1.73	1791.3	5.87	5.74	5.44	746.8	1.31	1.23	1.18
1696.6	1871.6	1.85	1.75	1.66	1871.6	5.42	5.31	5.06	786.6	1.39	1.31	1.25
1756.8	1931.8	1.81	1.70	1.61	1931.8	5.17	5.14	5.07	806.6	1.40	1.32	1.26
1837.2	2012.2	1.75	1.64	1.55	2012.2	4.75	4.73	4.64	846.4	1.43	1.35	1.30
1897.4	2072.4	1.73	1.63	1.53	2072.4	4.40	4.32	4.14	866.3	1.44	1.37	1.32
1977.7	2152.7	1.70	1.60	1.50	2152.7	4.09	4.06	3.97	906.1	1.48	1.42	1.37
2037.9	2212.9	1.66	1.56	1.47	2212.9	3.90	3.89	3.86	926.0	1.48	1.42	1.38
2118.2	2293.2	1.61	1.51	1.43	2293.2	3.59	3.56	3.50	965.9	1.57	1.51	1.48
2178.5	2353.5	1.59	1.49	1.42	2353.5	3.37	3.35	3.28	985.8	1.59	1.54	1.51
2258.8	2433.8	1.52	1.42	1.35	2433.8	3.13	3.12	3.10	1025.6	1.63	1.60	1.57
2319.0	2494.0	1.46	1.38	1.31	2494.0	2.91	2.90	2.88	1045.5	1.66	1.63	1.61
2399.3	2574.3	1.40	1.34	1.27	2574.3	2.59	2.57	2.50	1085.3	1.73	1.69	1.68
2459.6	2634.6	1.36	1.30	1.25	2634.6	2.37	2.37	2.35	1105.3	1.74	1.72	1.71
2539.9	2714.9	1.27	1.22	1.20	2714.9	2.07	2.07	2.06	1145.1	1.86	1.85	1.84
2600.1	2775.1	1.20	1.18	1.20	2775.1	1.86	1.85	1.82	1165.0	1.82	1.80	1.80

Frequency Mixer

Harmonics Tables

LAVI-10VH+

RF HARMONICS ORDER

	(-dBm)	(-dBc)										
0	-	-	27	35	40	35	40	44	41	58	59	51
1	-	30	+0	33	15	39	27	49	42	48	53	67
2	68	52	59	48	62	56	72	51	71	56	66	60
3	>90	82	62	84	59	83	62	80	70	82	74	80
4	>90	>90	>90	>90	>90	>90	88	>90	>90	83	90	>90
5	>90	>90	>90	90	>90	>90	85	>90	>90	88	89	>90
6	>90	>90	>90	>90	>90	88	>90	88	90	>90	>90	>90
7	>90	>90	>90	90	>90	>90	>90	>90	>90	>90	>90	89
8	>90	>90	>90	89	>90	>90	>90	>90	>90	>90	88	>90
9	>90	>90	>90	88	>90	88	>90	>90	>90	89	>90	85
10	>90	>90	>90	>90	>90	>90	>90	>90	>90	>90	89	>90
	RF CAL	0	1	2	3	4	5	6	7	8	9	10

LO HARMONICS ORDER

Test conditions: RF IN: 650 MHz; 5.00 dBm.
 LO IN: 825 MHz; +21.00 dBm
 IF OUT: 175 MHz; 0.03 dBm

RF HARMONICS ORDER

	(-dBm)	(-dBc)										
0	-	-	25	43	43	36	47	43	50	54	69	53
1	-	30	+0	34	15	41	29	52	42	51	45	66
2	49	42	51	37	56	47	63	42	62	50	59	56
3	88	67	44	64	40	64	43	63	51	68	57	69
4	>90	69	86	65	75	62	75	63	79	61	88	65
5	>90	91	72	84	66	87	71	86	71	80	79	85
6	>90	83	86	84	96	76	92	75	97	77	90	80
7	>90	98	88	96	95	98	84	87	87	88	82	90
8	88	>99	97	>99	95	95	95	89	93	92	96	90
9	>90	>99	>99	>99	>99	>99	94	>99	94	97	99	94
10	>90	98	>99	98	93	>99	93	96	>99	93	98	96
	RF CAL	0	1	2	3	4	5	6	7	8	9	10

LO HARMONICS ORDER

Test conditions: RF IN: 650 MHz; 15.00 dBm.
 LO IN: 825 MHz; +21.00 dBm
 IF OUT: 175 MHz; 9.28 dBm

- Notes: 1. All Harmonics are in (dBc) relative to IF OUTPUT.
 2. + entry denotes harmonics are in (dBc) above IF OUTPUT.
 3. RF Cal represent the Harmonics level of the RF input signal to the mixer.

Frequency Mixer

LAVI-10VH+

Typical Performance Curves

Conversion Loss @ IF=175MHz

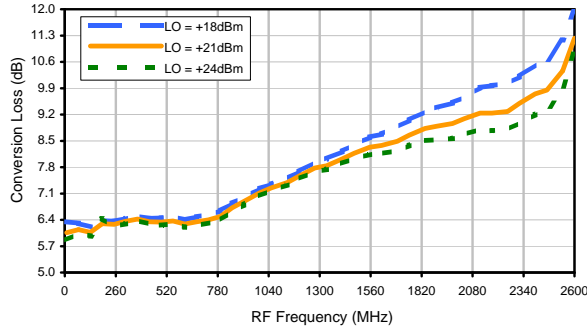

Conversion Loss vs. LO @ RF=650MHz

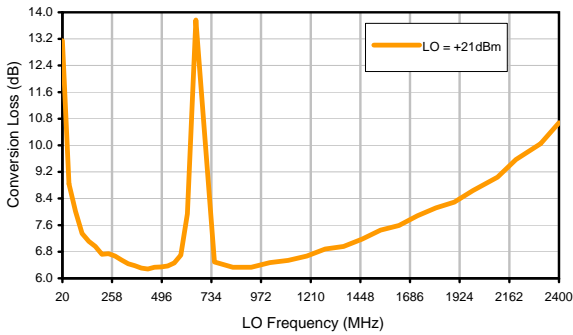

Conversion Loss vs. IF @ RF=650MHz

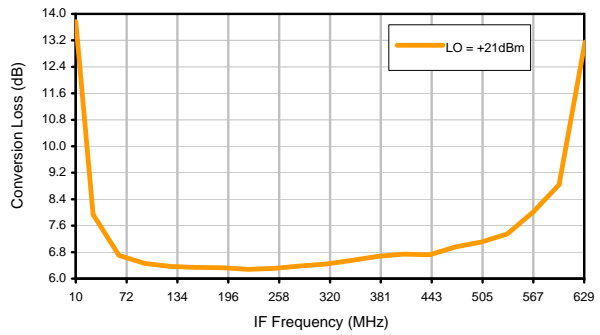

Conversion Loss vs. IF @ RF=300MHz

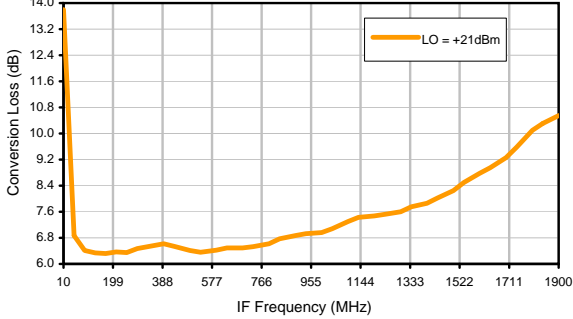

Conversion Loss vs. IF @ RF=1000.1MHz

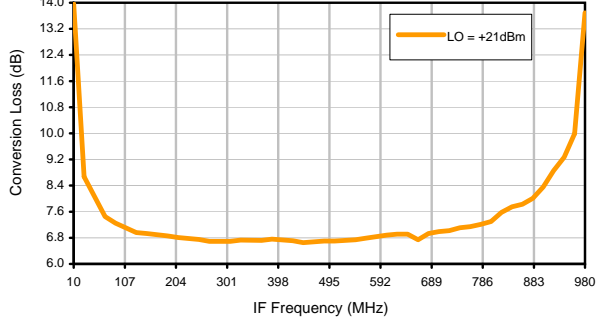

IP3 Input

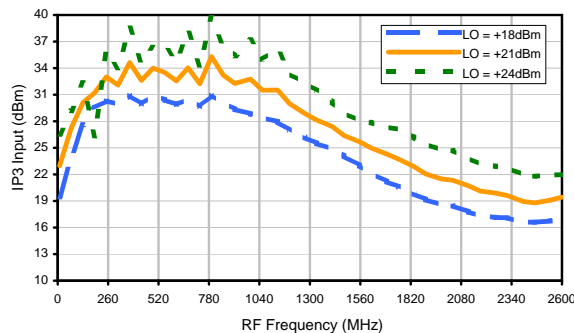

Frequency Mixer

LAVI-10VH+

Typical Performance Curves

LO-RF Isolation

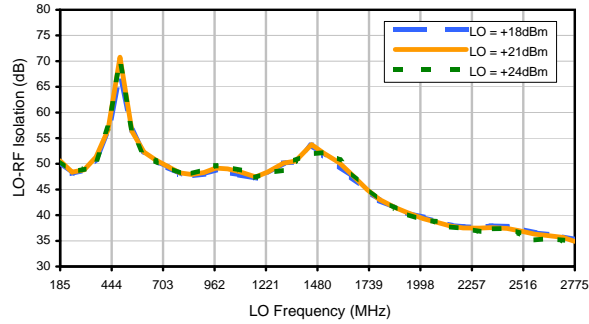

LO-IF Isolation

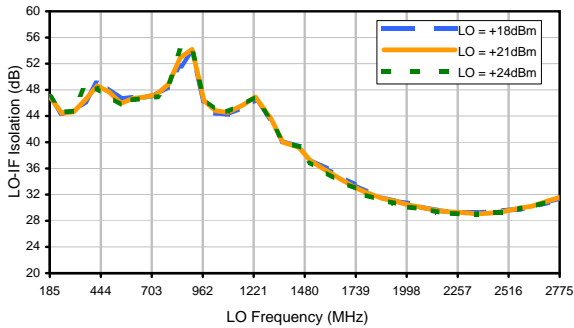

RF-IF Isolation

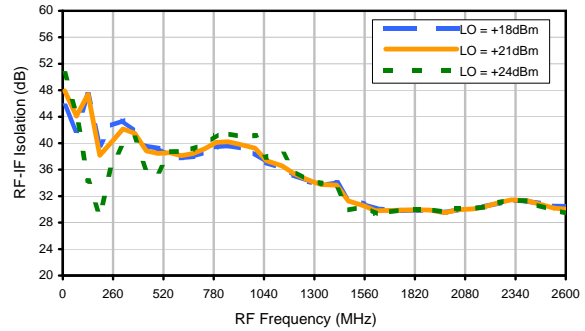

RF VSWR

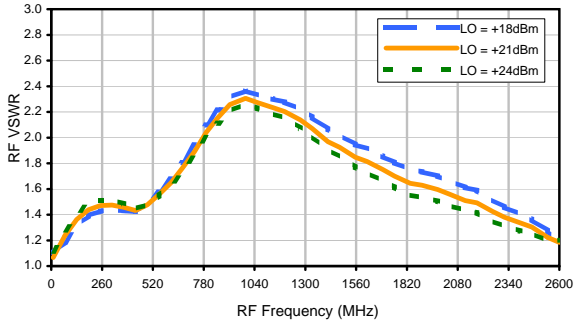

LO VSWR

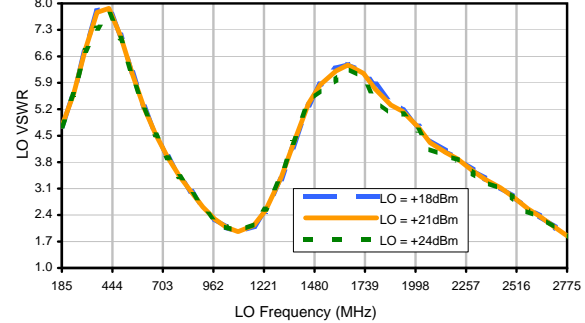

IF VSWR

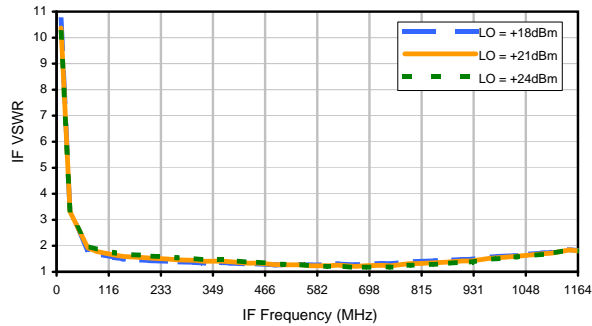

Frequency Mixer

Harmonics Tables

LAVI-10VH+

RF HARMONICS ORDER

	(-dBm)	(-dBc)										
0	-	-	27	35	40	35	40	44	41	58	59	51
1	-	30	+0	33	15	39	27	49	42	48	53	67
2	68	52	59	48	62	56	72	51	71	56	66	60
3	>90	82	62	84	59	83	62	80	70	82	74	80
4	>90	>90	>90	>90	>90	>90	88	>90	>90	83	90	>90
5	>90	>90	>90	90	>90	>90	85	>90	>90	88	89	>90
6	>90	>90	>90	>90	>90	88	>90	88	90	>90	>90	>90
7	>90	>90	>90	90	>90	>90	>90	>90	>90	>90	>90	89
8	>90	>90	>90	89	>90	>90	>90	>90	>90	>90	88	>90
9	>90	>90	>90	88	>90	88	>90	>90	>90	89	>90	85
10	>90	>90	>90	>90	>90	>90	>90	>90	>90	>90	89	>90
	RF CAL	0	1	2	3	4	5	6	7	8	9	10

LO HARMONICS ORDER

Test conditions: RF IN: 650 MHz; 5.00 dBm.
 LO IN: 825 MHz; +21.00 dBm
 IF OUT: 175 MHz; 0.03 dBm

RF HARMONICS ORDER

	(-dBm)	(-dBc)										
0	-	-	25	43	43	36	47	43	50	54	69	53
1	-	30	+0	34	15	41	29	52	42	51	45	66
2	49	42	51	37	56	47	63	42	62	50	59	56
3	88	67	44	64	40	64	43	63	51	68	57	69
4	>90	69	86	65	75	62	75	63	79	61	88	65
5	>90	91	72	84	66	87	71	86	71	80	79	85
6	>90	83	86	84	96	76	92	75	97	77	90	80
7	>90	98	88	96	95	98	84	87	87	88	82	90
8	88	>99	97	>99	95	95	95	89	93	92	96	90
9	>90	>99	>99	>99	>99	>99	94	>99	94	97	99	94
10	>90	98	>99	98	93	>99	93	96	>99	93	98	96
	RF CAL	0	1	2	3	4	5	6	7	8	9	10

LO HARMONICS ORDER

Test conditions: RF IN: 650 MHz; 15.00 dBm.
 LO IN: 825 MHz; +21.00 dBm
 IF OUT: 175 MHz; 9.28 dBm

- Notes: 1. All Harmonics are in (dBc) relative to IF OUTPUT.
 2. + entry denotes harmonics are in (dBc) above IF OUTPUT.
 3. RF Cal represent the Harmonics level of the RF input signal to the mixer.

Outline Dimensions

PCB Land Pattern

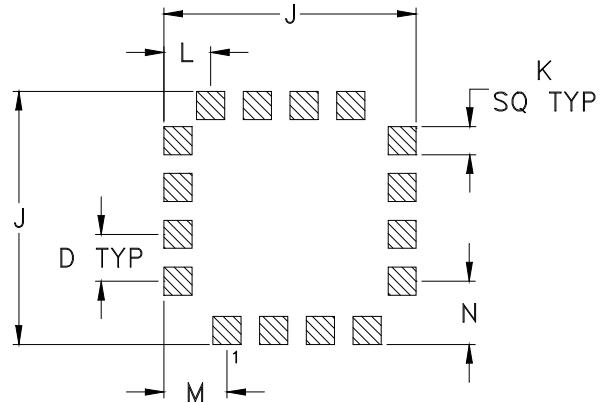
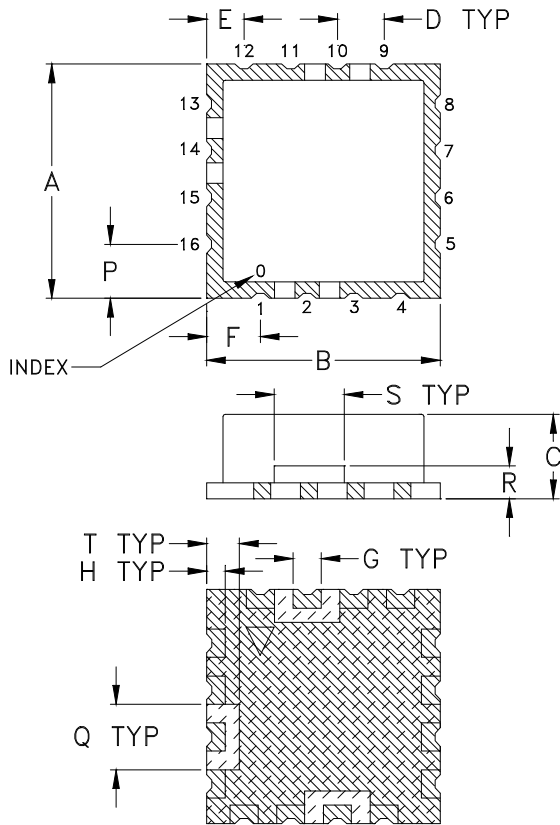

Suggested Layout,
Tolerance to be within $\pm .002$

CASE #	A	B	C	D	E	F	G	H	J	K
CK605	.500 (12.70)	.500 (12.70)	.180 (4.57)	.100 (2.54)	.080 (2.03)	.115 (2.92)	.060 (1.52)	.040 (1.02)	.540 (13.72)	.060 (1.52)

CASE #	L	M	N	P	Q	R	S	T	WT. GRAM
CK605	.100 (2.54)	.135 (3.43)	.135 (3.43)	.115 (2.92)	.140 (3.56)	.070 (1.78)	.150 (3.81)	.070 (1.78)	1.2 +0.5 -0.0

Dimensions are in inches (mm). Tolerances: 2 Pl. $\pm .03$; 3Pl. $\pm .015$

Notes:

- Case material: Nickel-Silver alloy.
- Base: Printed wiring laminate.
- Termination finish:
 For RoHS Case Styles: 3-5 μ inch (.08-.13 microns) Gold over 120-240 μ inch (3.05-6.10 microns) Nickel plate.
 All models, (+) suffix.



P.O. Box 350166, Brooklyn, New York 11235-0003 (718) 934-4500 Fax (718) 332-4661 For detailed performance specs & shopping online see Mini-Circuits web site



The Design Engineers Search Engine Provides ACTUAL Data Instantly From MINI-CIRCUITS At: www.minicircuits.com

RF/IF MICROWAVE COMPONENTS

Tape & Reel Packaging TR-F37

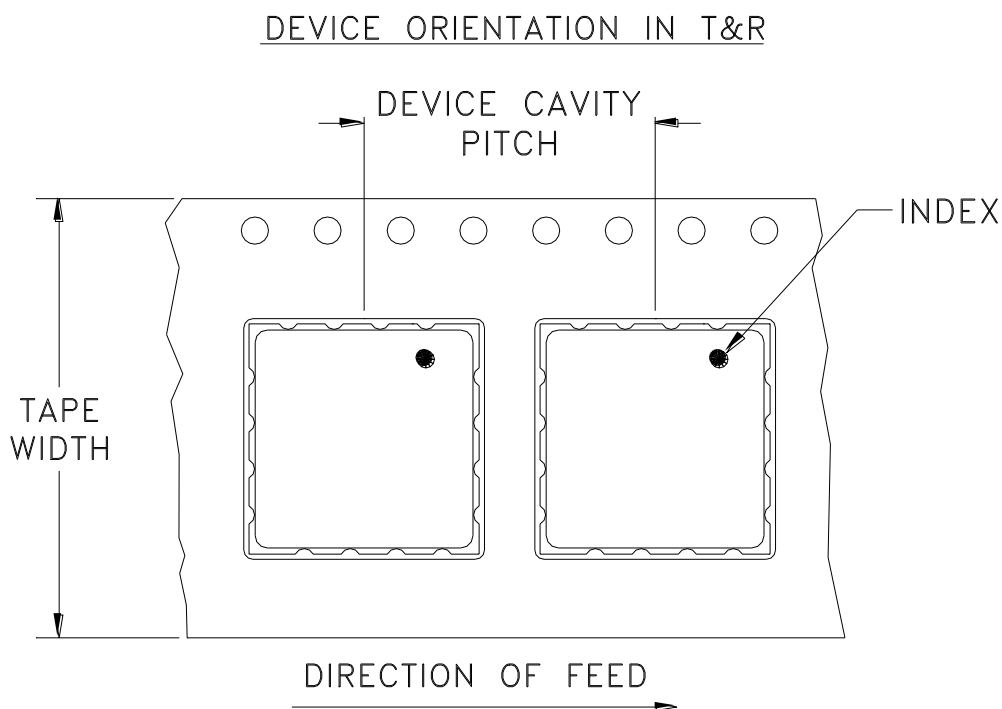

Tape Width, mm	Device Cavity Pitch, mm	Reel Size, inches	Devices per Reel	
24	16	7	Small quantity standards (see note)	10
				20
				50
				100
		13	Standard	200
500				

Note: Please consult individual model data sheet to determine device per reel availability.

Mini-Circuits carrier tape materials provide protection from ESD (Electro-Static Discharge) during handling and transportation. Tapes are static dissipative and comply with industry standards EIA-481/EIA-541.

Go to: www.minicircuits.com/pages/pdfs/tape.pdf



INTERNET <http://www.minicircuits.com>

P.O. Box 350166, Brooklyn, New York 11235-0003 (718) 934-4500 Fax (718) 332-4661

Distribution Centers NORTH AMERICA 800-654-7949 • 417-335-5935 • Fax 417-335-5945 • EUROPE 44-1252-832600 • Fax 44-1252-837010

Mini-Circuits ISO 9001 & ISO 14001 Certified

THIRD ANGLE PROJECTION

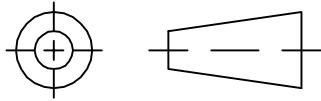

REVISIONS

REV	ECN No.	DESCRIPTION	DATE	DR	AUTH
E	M105563	ADDED "r1" PIN CONNECTION	06/02/06	MMG	DJ
F	M105640	CORRECTED NOTE 2	06/08/06	MMG	MM
G	M124395	ADDED "RAMP"	09/09	EM	HH
G	R77589	ADDED "RAMP"	09/09	EM	HH

SUGGESTED MOUNTING CONFIGURATION FOR CK605 CASE STYLE, "kg/rl/16AM01" PIN CONNECTION

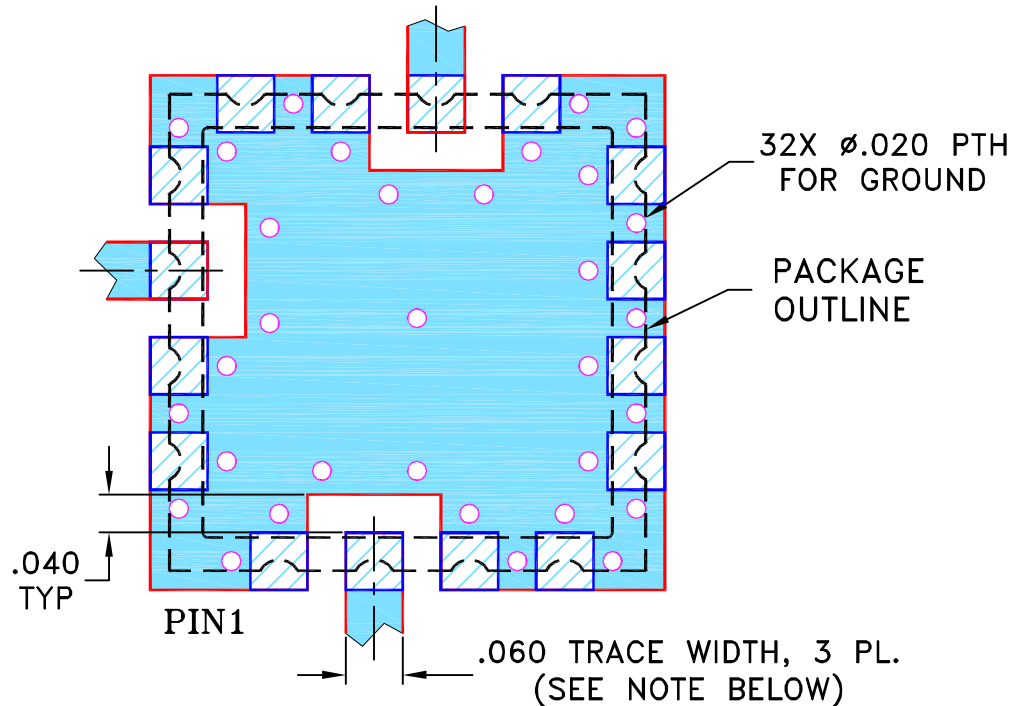

NOTES:

1. TRACE WIDTH IS SHOWN FOR FR4 WITH DIELECTRIC THICKNESS .030" ± .002"; COPPER: 1/2 OZ. EACH SIDE. FOR OTHER MATERIALS TRACE WIDTH MAY NEED TO BE MODIFIED.
2. BOTTOM SIDE OF THE BOTTOM IS CONTINUOUS GROUND PLANE.

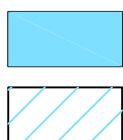

DENOTES PCB COPPER LAYOUT WITH SMOBC (SOLDER MASK OVER BARE COPPER)

DENOTES COPPER LAND PATTERN FREE OF SOLDER MASK

UNLESS OTHERWISE SPECIFIED	INITIALS	DATE
DIMENSIONS ARE IN INCHES	AV	08/07/00
TOLERANCES ON:	SK	08/08/00
2 PL DECIMALS ±	DB	08/08/00
3 PL DECIMALS ± .005		
ANGLES ±		
FRACTIONS ±		

 **Mini-Circuits®** 13 Neptune Avenue
Brooklyn NY 11235

PL,kg/rl/16AM01,CK605,ROS/LAVI/RAMP

SIZE	CODE IDENT	DRAWING NO:	REV:
A	15542	98-PL-012	G
FILE:	98PL012	SCALE: 5:1	SHEET: 1 OF 1

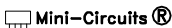
 Mini-Circuits®
THIS DOCUMENT AND ITS CONTENTS ARE THE PROPERTY OF MINI-CIRCUITS. EXCEPT FOR USE EXPRESSLY GRANTED, IN WRITING, TO ITS VENDORS, VENDEE AND THE UNITED STATES GOVERNMENT, MINI-CIRCUITS RESERVES ALL PROPRIETARY DESIGN, USE, MANUFACTURING AND REPRODUCTION RIGHTS THERETO. THESE CONTENTS SHALL NOT BE USED, DUPLICATED OR DISCLOSED TO ANY OUTSIDE PARTY, IN WHOLE OR IN PART, WITHOUT WRITTEN PERMISSION OF MINI-CIRCUITS.

Evaluation Board and Circuit

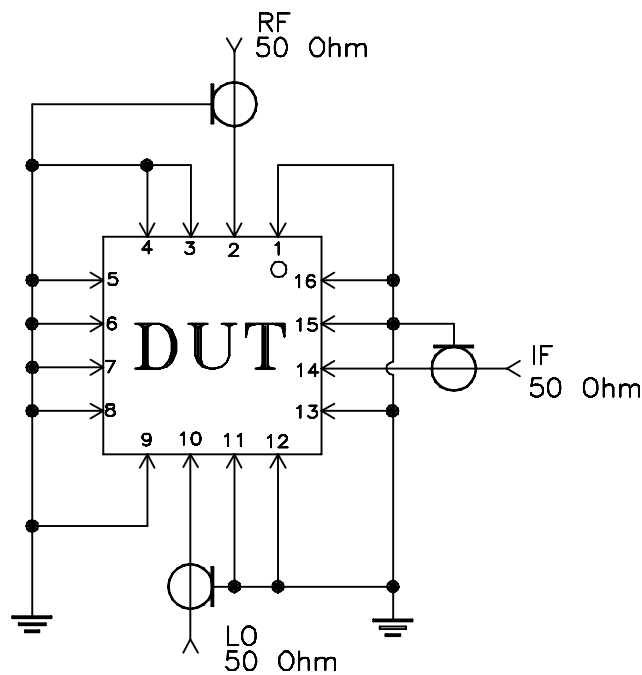
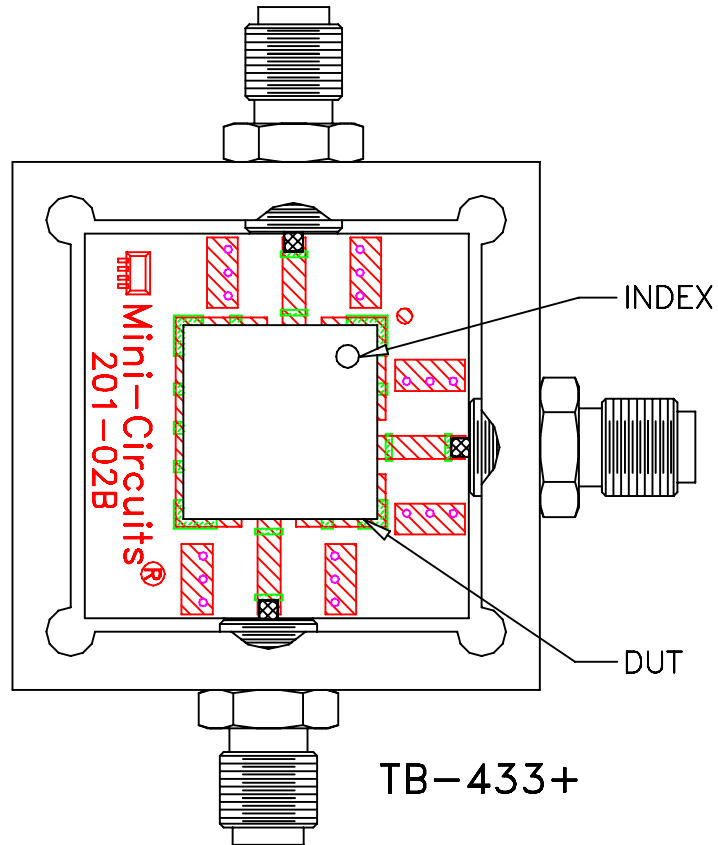

Notes:

1. SMA Female connectors.
2. PCB Material: Rogers R04350 or equivalent,
Dielectric Constant=3.5, Thickness=.028 inch.

Schematic Diagram

 **Mini-Circuits®**

All Mini-Circuits products are manufactured under exacting quality assurance and control standards, and are capable of meeting published specifications after being subjected to any or all of the following physical and environmental test.

Specification	Test/Inspection Condition	Reference/Spec
Operating Temperature	-45° to 85°C Ambient Environment	Individual Model Data Sheet
Storage Temperature	-55° to 100° C Ambient Environment	Individual Model Data Sheet
Humidity	90 to 95% RH, 240 hours, 50°C	MIL-STD-202, Method 103, Condition A, Except 50°C and end-point electrical test done within 12 hours
Thermal Shock	-55° to 100°C, 100 cycles	MIL-STD-202, Method 107, Condition A-3, except +100°C
Solder Reflow Heat	Sn-Pb Eutectic Process: 225°C peak Pb-Free Process, 245°C peak	J-STD-020, Table 4-1, 4-2 and 5-2, Figure 5-1
Solderability	10X Magnification	J-STD-002, 95% Coverage
Vibration (High Frequency)	20g peak, 10-2000 Hz, 12 times in each of three perpendicular directions (total 36)	MIL-STD-202, Method 204, Condition D
Mechanical Shock	50g, 11 ms, 1/2-sine, 18 shocks: 3 each direction, each of 3 axes	MIL-STD-202, Method 213, Condition A
Marking Resistance to Solvents	Isopropyl alcohol + mineral spirits at 25°C; terpene defluxer at 25°C; distilled water + proylene glycol monomethyl ether + monoethanolamine at 63°C to 70°C	MIL-STD-202, Method 215