



COAXIAL

# Adapter

## KMR-24F+

50Ω DC to 40 GHz Right-Angle 2.4 mm-Female to 2.92 mm-Male

### THE BIG DEAL

- Ultra-Wideband, DC to 40 GHz
- Low Insertion Loss, 0.16 dB Typ.
- Excellent VSWR, 1.09:1 Typ.
- Flat response



Generic photo used for illustration purposes only

### APPLICATIONS

- Interconnection of RF cable and equipment

Model No.	KMR-24F+
Case Style	DJ2442-9
Connectors	Right Angle 2.4 mm F to 2.92 mm M

**+RoHS Compliant**  
 The +Suffix identifies RoHS Compliance.  
 See our website for methodologies and qualifications

### PRODUCT OVERVIEW

Mini-Circuits' KMR-24F+ is a right-angle 2.4 mm-F to 2.92 mm-M adapter supporting a wide range of applications from DC to 40 GHz. This model provides excellent VSWR, low insertion loss, and flat response versus frequency. The KMR-24F+ features passivated stainless steel construction and gold-plated berillium copper construction center contact.

### KEY FEATURES

Features	Advantages
Right-Angle adapter	Converts 2.4 F to K-connector (Right-Angle) in one unit saving space and cost
Wideband, DC to 40 GHz	Wide frequency range provides application flexibility and makes this model ideal for broadband and multi-band use.
Excellent VSWR, 1.09:1 typ.	Provides good matching for 50Ω systems and minimizes signal reflections across wide frequency range.
Low insertion loss, 0.16 dB typ.	Provides excellent signal power transmission from input to output.
Passivated stainless steel construction and gold-plated berillium copper center contact	Stands up to wear and tear in demanding environments and provides excellent reliability.
Very wide operating temperature range, -55 to +100 °C	Withstands extreme operating conditions and is suitable for use near high power componentry where heat rise is common.



COAXIAL

# Adapter

## KMR-24F+

50Ω DC to 40 GHz Right-Angle 2.4 mm-Female to 2.92 mm-Male

### ELECTRICAL SPECIFICATIONS AT 25°C

Parameter	Frequency (GHz)	Min.	Typ.	Max.	Units
Frequency Range	-	DC	-	40	GHz
Insertion Loss	DC - 40	-	0.16	0.4	dB
VSWR	DC - 40	-	1.09	1.29	:1

### ABSOLUTE MAXIMUM RATINGS

Parameter	Ratings
Operating Temperature	-55°C to 100°C
Storage Temperature	-55°C to 100°C

Permanent damage may occur if any of these limits are exceeded.



COAXIAL

# Adapter

**KMR-24F+**

50Ω DC to 40 GHz Right-Angle 2.4 mm-Female to 2.92 mm-Male

## COAXIAL CONNECTIONS

Connector 1	2.4 mm -Female
Connector 2	2.92 mm -Male

## OUTLINE DRAWING

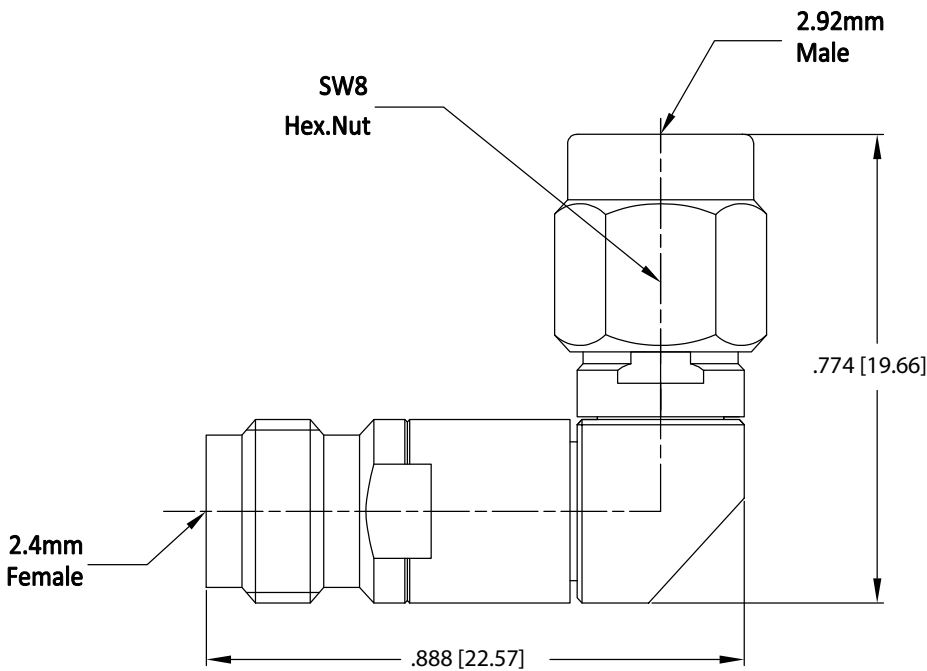

Weight: 6 grams  
Dimensions are in inches [mm]



COAXIAL

# Adapter

## KMR-24F+

Mini-Circuits

50Ω DC to 40 GHz Right-Angle 2.4 mm-Female to 2.92 mm-Male

### TYPICAL PERFORMANCE DATA AND CHARTS

Frequency (MHz)	Insertion Loss (dB)	VSWR (:1)	
		2.4mm-Female	2.92mm-Male
10	0.01	1.01	1.01
100	0.01	1.01	1.00
500	0.03	1.01	1.02
1000	0.05	1.02	1.02
2000	0.07	1.01	1.02
3000	0.10	1.02	1.01
5000	0.14	1.08	1.08
7000	0.13	1.11	1.11
10000	0.13	1.06	1.03
15000	0.14	1.06	1.01
20000	0.17	1.07	1.03
25000	0.18	1.05	1.03
30000	0.24	1.18	1.12
33000	0.23	1.09	1.15
35000	0.25	1.10	1.09
38000	0.24	1.18	1.14
40000	0.21	1.06	1.07

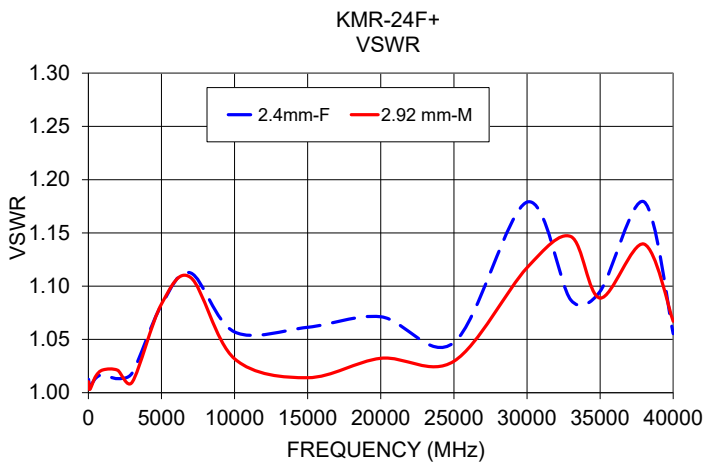
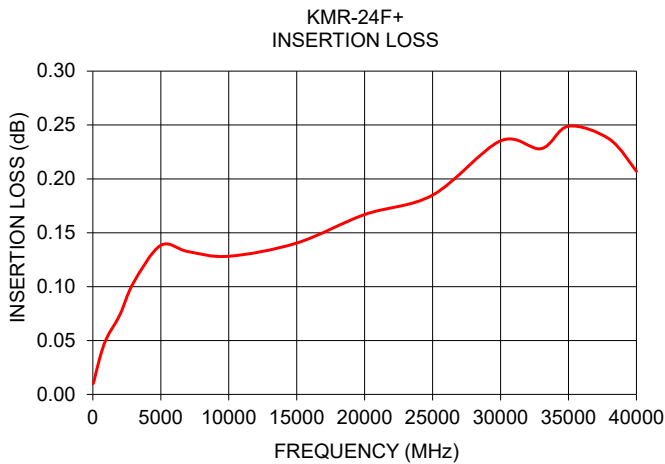

#### NOTES

- A. Performance and quality attributes and conditions not expressly stated in this specification document are intended to be excluded and do not form a part of this specification document.
- B. Electrical specifications and performance data contained in this specification document are based on Mini-Circuit's applicable established test performance criteria and measurement instructions.
- C. The parts covered by this specification document are subject to Mini-Circuits standard limited warranty and terms and conditions (collectively, "Standard Terms"); Purchasers of this part are entitled to the rights and benefits contained therein. For a full statement of the standard terms and the exclusive rights and remedies thereunder, please visit Mini-Circuits' website at [www.minicircuits.com/terms/viewterm.html](http://www.minicircuits.com/terms/viewterm.html)



# Right Angle Adapter, 2.92mm Male to 2.4mm Female KMR-24F+

## Typical Performance Data

FREQUENCY (GHz)	INSERTION LOSS (dB)	2.92mm-MALE VSWR (:1)	2.4mm-FEMALE VSWR (:1)
0.01	0.01	1.01	1.01
0.05	0.01	1.00	1.00
0.1	0.01	1.01	1.00
0.2	0.02	1.01	1.01
0.3	0.02	1.01	1.01
0.4	0.03	1.01	1.01
0.5	0.03	1.01	1.02
0.6	0.04	1.01	1.02
0.7	0.04	1.02	1.02
0.8	0.04	1.02	1.02
0.9	0.05	1.02	1.02
1.0	0.05	1.02	1.02
2.0	0.07	1.01	1.02
3.0	0.10	1.02	1.01
4.0	0.13	1.05	1.04
5.0	0.14	1.08	1.08
6.0	0.14	1.11	1.11
7.0	0.13	1.11	1.11
8.0	0.13	1.10	1.09
9.0	0.13	1.08	1.05
10.0	0.13	1.06	1.03
11.0	0.13	1.04	1.02
12.0	0.13	1.04	1.02
13.0	0.13	1.04	1.03
14.0	0.14	1.05	1.03
15.0	0.14	1.06	1.01
16.0	0.14	1.06	1.02
17.0	0.15	1.04	1.05
18.0	0.15	1.02	1.05
19.0	0.16	1.03	1.03
20.0	0.17	1.07	1.03
21.0	0.18	1.12	1.10
22.0	0.20	1.15	1.16
23.0	0.20	1.15	1.16
24.0	0.20	1.11	1.11
25.0	0.18	1.05	1.03
26.0	0.19	1.04	1.06
28.0	0.22	1.16	1.19
30.0	0.24	1.18	1.12
32.0	0.24	1.15	1.13
34.0	0.23	1.00	1.13
36.0	0.27	1.18	1.11
38.0	0.24	1.18	1.14
40.0	0.21	1.06	1.07
42.0	0.21	1.17	1.07
43.0	0.21	1.20	1.04
43.5	0.21	1.20	1.02



P.O. Box 350166, Brooklyn, New York 11235-0003 • (718) 934-4500 • Fax (718) 332-4661 For detailed performance specs & shopping online see Mini-Circuits web site  
 The Design Engineers Search Engine Provides ACTUAL Data Instantly From MINI-CIRCUITS At: [www.minicircuits.com](http://www.minicircuits.com)



IF/RF MICROWAVE COMPONENTS

REV. OR  
 KMR-24F+  
 11/6/2019  
 Page 1 of 1

Typical Performance Curves

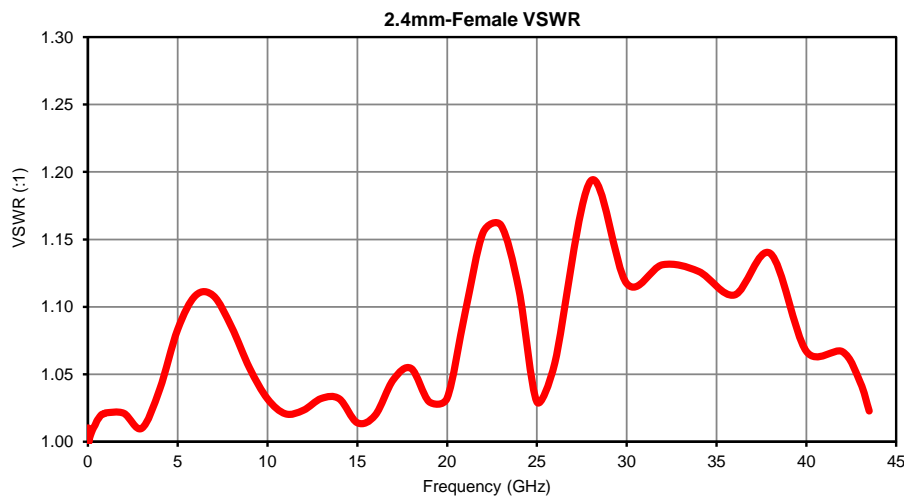
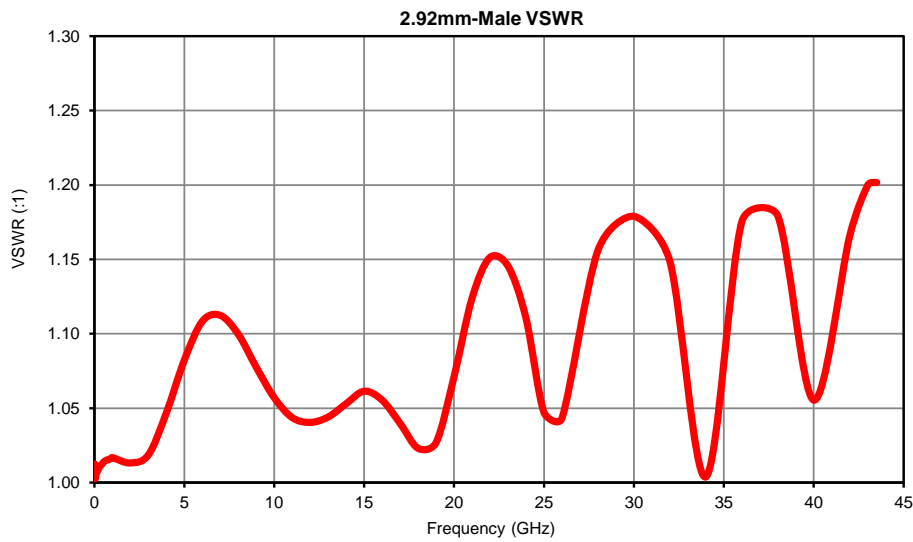
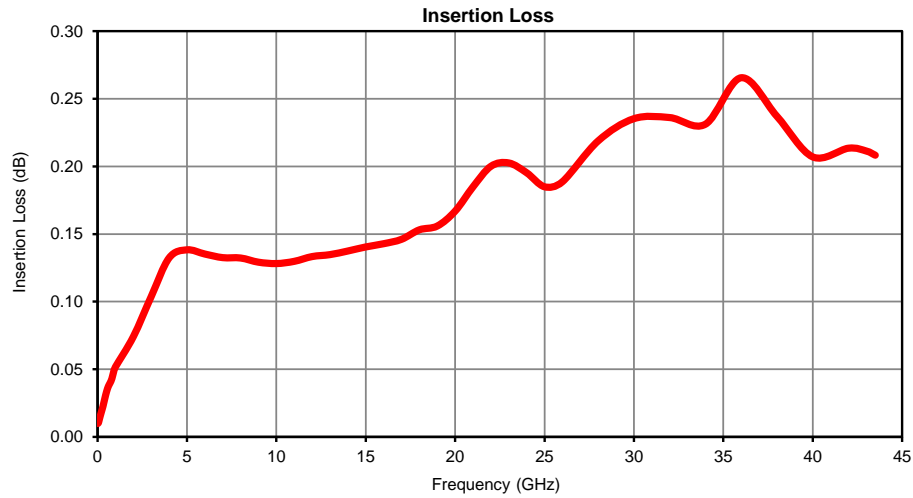

# Case Style

DJ

## Outline Dimensions

DJ2442-9

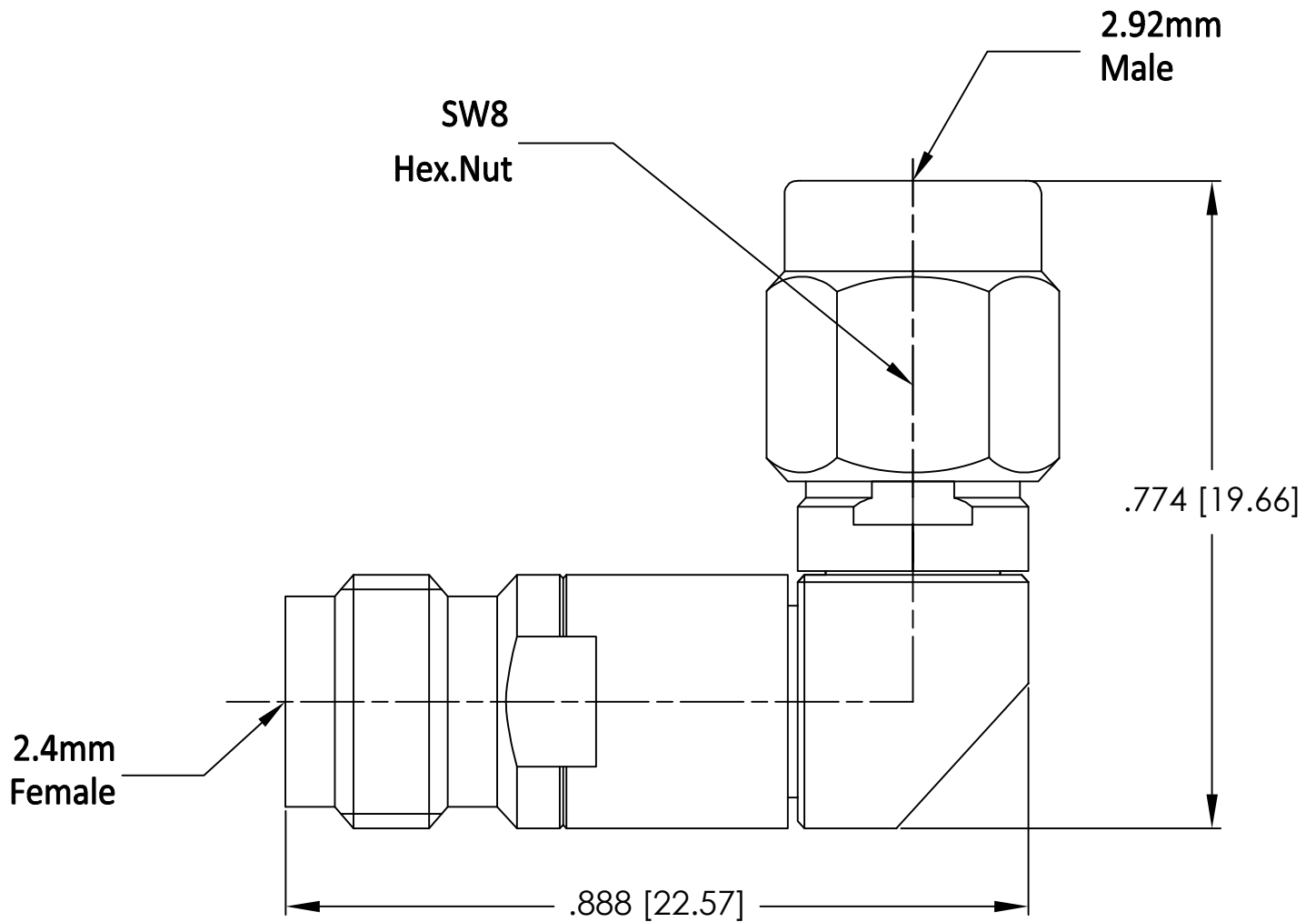

Weight: 6 grams.

Dimensions are in inches (mm). Tolerances: 2 Pl.±.030; 3 Pl. ±.015

### Notes:

1. Case material: Stainless Steel..
2. Finish: Passivation.

**Mini-Circuits®**  
ISO 9001 ISO 14001 CERTIFIED

ALL NEW  
minicircuits.com

P.O. Box 350166, Brooklyn, New York 11235-0003 (718) 934-4500 Fax (718) 332-4661 For detailed performance specs & shopping online see Mini-Circuits web site



The Design Engineers Search Engine Provides ACTUAL Data Instantly From MINI-CIRCUITS At: [www.minicircuits.com](http://www.minicircuits.com)

RF/IF MICROWAVE COMPONENTS

All Mini-Circuits products are manufactured under exacting quality assurance and control standards, and are capable of meeting published specifications after being subjected to any or all of the following physical and environmental test.

<b>Specification</b>	<b>Test/Inspection Condition</b>	<b>Reference/Spec</b>
Operating Temperature	-55° to 100°C Ambient Environment	Individual Model Data Sheet
Storage Temperature	-55° to 100° C Ambient Environment	Individual Model Data Sheet
Barometric Pressure	100,000 Feet	MIL-STD-202, Method 105, Condition D
Humidity	90% RH, 65°C Units may require bake-out after humidity to restore full performance.	MIL-STD-202, Method 103
Thermal Shock	-65° to 125°C, 5 cycles	MIL-STD-202, Method 107, Condition B
Vibration (High Frequency)	20g peak, 10-2000 Hz, 12 times in each of three perpendicular directions (total 36)	MIL-STD-202, Method 204, Condition D
Mechanical Shock	100g, 6ms sawtooth, 3 shocks each direction 3 axes (total 18)	MIL-STD-202, Method 213, Condition I