

X2 Frequency Multiplier

NON-CATALOG

KBA-40

50Ω Output 5400 to 9600 MHz



Generic photo used for illustration purposes only

CASE STYLE: SM2

Maximum Ratings

Operating Temperature	-40°C to 85 °C
Storage Temperature	-55°C to 100°C
RF Input Power	200mW
Permanent damage may occur if any of these limits are exceeded.	

Pin Connections

INPUT	10
OUTPUT	6
SAMPLE*	1
GROUND	2,3,4,5,7,8,9

* Sample port output power, -10 dBc typ.
Terminate in 50 ohms if not used.

Outline Drawing

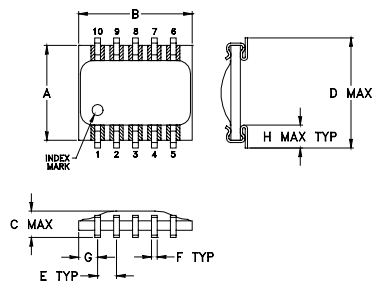

PCB Land Pattern

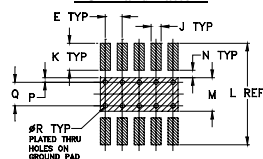

Suggested Layout,

Tolerance to be within ±.002
ADJACENT GROUND PINS SHALL BE CONNECTED TO EACH OTHER AND TO GROUND PAD

Outline Dimensions (inch/mm)

A	B	C	D	E	F	G	H	
.250	.300	.095	.290	.050	.115	.050	.060	
6.35	7.62	2.41	7.37	1.27	2.93	1.27	1.52	
J	K	L	M	N	P	Q	R	wt
.030	.080	.300	.100	.020	.015	.070	.014	grams
0.76	2.03	7.62	2.54	0.51	0.38	1.78	0.36	0.3

Demo Board MCL P/N: TB-74 Suggested PCB Layout (PL-067)

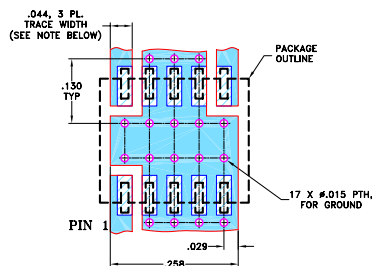

- NOTES: 1. TRACE WIDTH IS SHOWN FOR ROGERS RO4350B WITH DIELECTRIC THICKNESS 0.020" ± 0.0015"; COPPER: 1/2 OZ. EACH SIDE. FOR OTHER MATERIALS TRACE WIDTH MAY NEED TO BE MODIFIED.
2. BOTTOM SIDE OF THE PCB IS CONTINUOUS GROUND PLANE.
3. DENOTES PCB COPPER LAYOUT WITH SMOBC (SOLDER MASK OVER BARE COPPER)
4. DENOTES COPPER LAND PATTERN FREE OF SOLDER MASK

Notes

- A. Performance and quality attributes and conditions not expressly stated in this specification document are intended to be excluded and do not form a part of this specification document.
B. Electrical specifications and performance data contained in this specification document are based on Mini-Circuit's applicable established test performance criteria and measurement instructions.
C. The parts covered by this specification document are subject to Mini-Circuit's standard limited warranty and terms and conditions (collectively, "Standard Terms"); Purchasers of this part are entitled to the rights and benefits contained therein. For a full statement of the Standard Terms and the exclusive rights and remedies thereunder, please visit Mini-Circuit's website at www.minicircuits.com/MCLStore/terms.jsp

Features

- wideband, 5400 to 9600 MHz
- low insertion loss, 12.3 dB typ.
- low profile, 0.070" max.
- aqueous washable
- protected by U.S patent 5,534,830

Applications

- synthesizers
- local oscillators

Electrical Specifications

MULTIPLICATION FACTOR	FREQUENCY (MHz)		INPUT POWER (dBm)	CONVERSION LOSS (dB)	*HARMONIC OUTPUT (dBc)					
	F1	F2			F1		F3		F4	
	Input	Output			Typ.	Min.	Typ.	Min.	Typ.	Min.
2	2700-4800	5400-9600	10	16	18	10	26	15	24	14
	2700-4800	5400-9600	5	10	13	8	26	16	26	12

* Harmonics of input frequency below the power level of F2

Typical Performance Data 25°C

Input Frequency (MHz)	Conversion Loss (dB) F2	Harmonic Output (-dBc)		
		F1	F3	F4
2700.00	14.26	27.19	35.82	15.80
2750.00	13.90	26.33	40.98	16.70
2900.00	12.84	21.84	33.70	19.39
3000.00	12.90	22.03	34.30	21.18
3200.00	13.59	25.82	43.18	20.79
3600.00	10.77	23.96	26.54	24.70
3800.00	11.60	18.24	23.18	31.24
4000.00	12.09	17.42	21.89	34.19
4400.00	13.44	19.00	34.16	36.27
4800.00	13.61	18.85	29.53	38.03

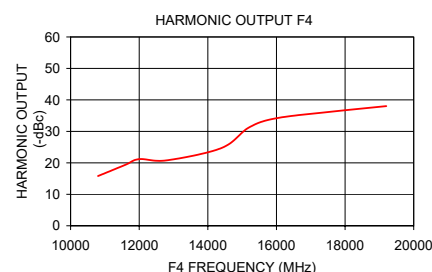
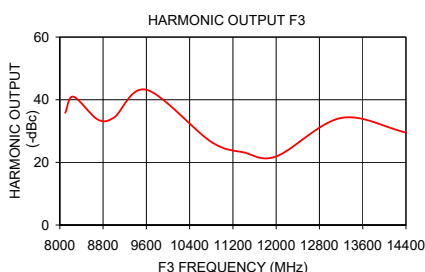
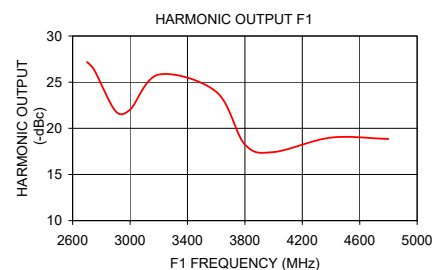
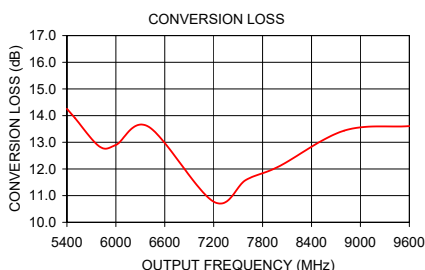

Frequency Multiplier (Doublers)

KBA-40

Typical Performance Data

FREQUENCY (MHz)				CONVERSION LOSS (dB)	HARMONIC OUTPUT*		
X 1 OUTPUT	X 2 OUTPUT	X 3 OUTPUT	X 4 OUTPUT	X 2 OUTPUT	X 1 OUTPUT	X 3 OUTPUT	X 4 OUTPUT
2700	5400	8100	10800	14.26	27.19	35.82	15.80
2750	5500	8250	11000	13.90	26.33	40.98	16.70
2900	5800	8700	11600	12.84	21.84	33.70	19.39
3000	6000	9000	12000	12.90	22.03	34.30	21.18
3200	6400	9600	12800	13.59	25.82	43.18	20.79
3600	7200	10800	14400	10.77	23.96	26.54	24.70
3800	7600	11400	15200	11.60	18.24	23.18	31.24
4000	8000	12000	16000	12.09	17.42	21.89	34.19
4400	8800	13200	17600	13.44	19.00	34.16	36.27
4800	9600	14400	19200	13.61	18.85	29.53	38.03

*Harmonic Output below power level of X 2 Output .

Frequency Multiplier (Doubler)

KBA-40

Typical Performance Curves

Conversion Loss X 2 Output

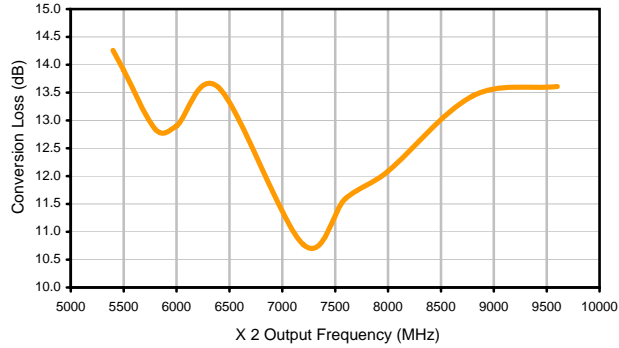

Harmonic X 1 Output

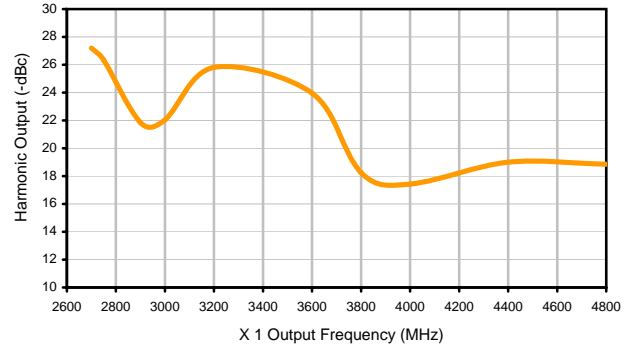

Harmonic X 3 Output

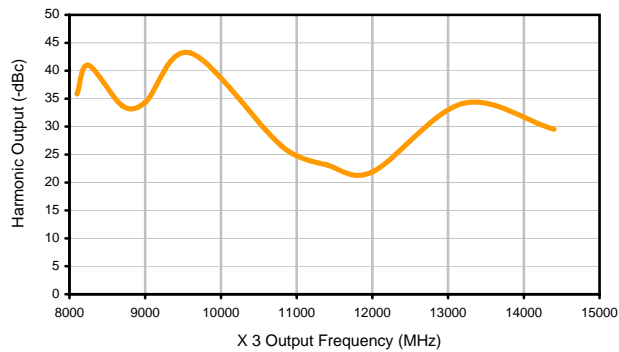

Harmonic X 4 Output

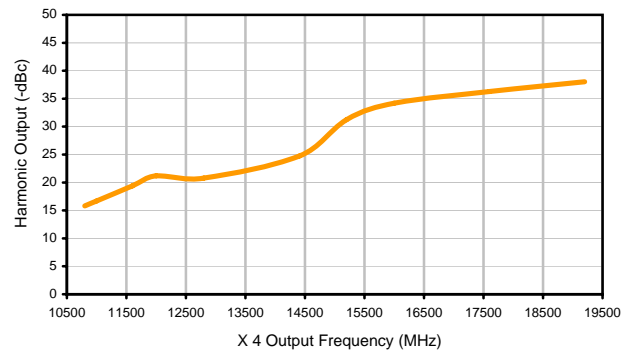

Case Style

SM2

SM2

Outline Dimensions

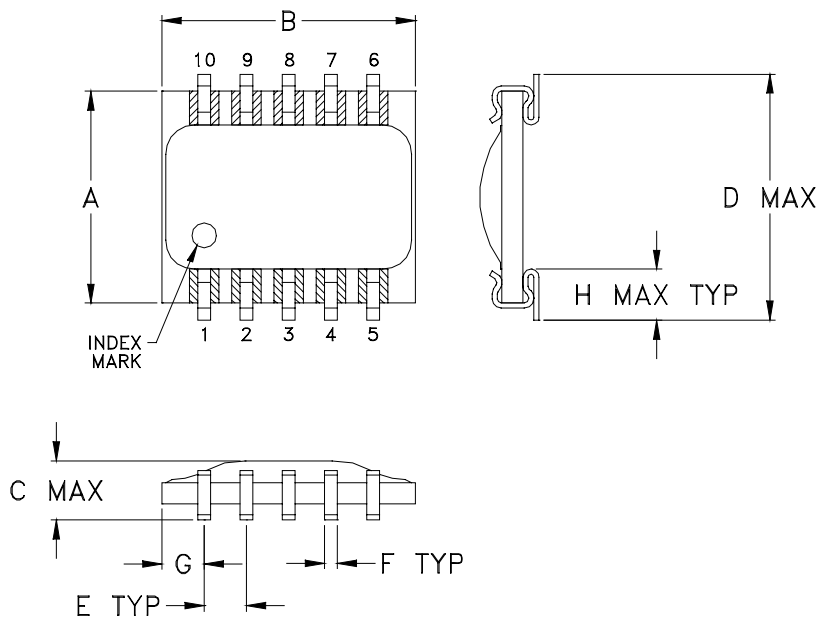

PCB Land Pattern

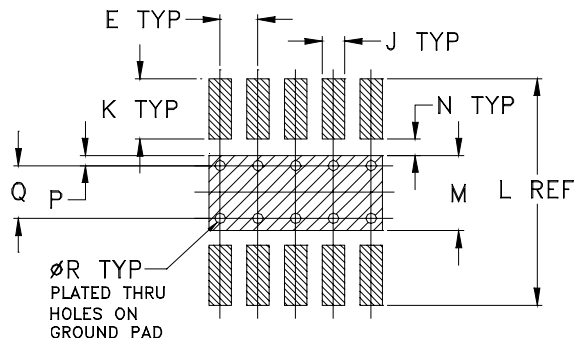

Suggested Layout,
Tolerance to be within $\pm .002$

ADJACENT GROUND PINS SHALL BE CONNECTED
TO EACH OTHER AND TO GROUND PAD

CASE #	A	B	C	D	E	F	G	H	J	K	L	M	N	P
SM2	.250 (6.35)	.300 (7.62)	.095 (2.41)	.290 (7.37)	.050 (1.27)	.015 (0.38)	.050 (1.27)	.060 (1.52)	.030 (0.76)	.080 (2.03)	.300 (7.62)	.100 (2.54)	.020 (0.51)	.015 (0.38)

CASE #	Q	R	WT. GRAM
SM2	.070 (1.78)	.014 (0.36)	.3

Dimensions are in inches (mm). Tolerances: $\pm .005$

Notes:

1. Case material: Plastic encapsulation on Ceramic base.
2. Termination finish:
For RoHS Case Styles: Tin plate over Nickel plate.
For RoHS-5 Case Styles: Tin-Lead plate.



INTERNET <http://www.minicircuits.com>

P.O. Box 350166, Brooklyn, New York 11235-0003 (718) 934-4500 Fax (718) 332-4661

Distribution Centers NORTH AMERICA 800-654-7949 • 417-335-5935 • Fax 417-335-5945 • EUROPE 44-1252-832600 • Fax 44-1252-837010

Mini-Circuits ISO 9001 & ISO 14001 Certified

Tape & Reel Packaging TR-F34

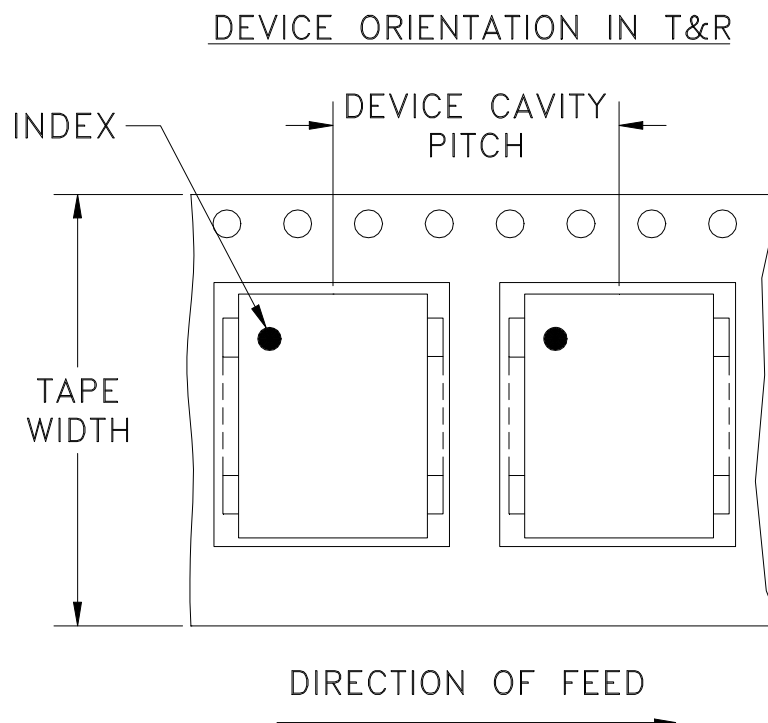

Tape Width, mm	Device Cavity Pitch, mm	Reel Size, inches	Devices per Reel see note	
16	12	7	Small quantity standard (see note)	20
				50
				100
				200
		13	Standard	500
				1000

Note: Availability of small reel quantity varies by model.
Refer to pricing and availability on individual model dashboard.

Mini-Circuits carrier tape materials provide protection from ESD (Electro-Static Discharge) during handling and transportation. Tapes are static dissipative and comply with industry standards EIA-481/EIA-541.

Go to: www.minicircuits.com/pages/pdfs/tape.pdf



INTERNET <http://www.minicircuits.com>

P.O. Box 350166, Brooklyn, New York 11235-0003 (718) 934-4500 Fax (718) 332-4661

Distribution Centers NORTH AMERICA 800-654-7949 • 417-335-5935 • Fax 417-335-5945 • EUROPE 44-1252-832600 • Fax 44-1252-837010

Mini-Circuits ISO 9001 & ISO 14001 Certified

THIRD ANGLE PROJECTION

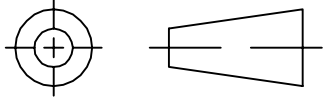

REVISIONS

REV	ECN No.	DESCRIPTION	DATE	DR	AUTH
OR	M82272	NEW RELEASE	08/02/02	AV	DJ
A	M102713	UPDATED NOTES	01/14/06	GF	IL

SUGGESTED MOUNTING CONFIGURATION FOR SM2 CASE STYLE, "le" PIN CONNECTION

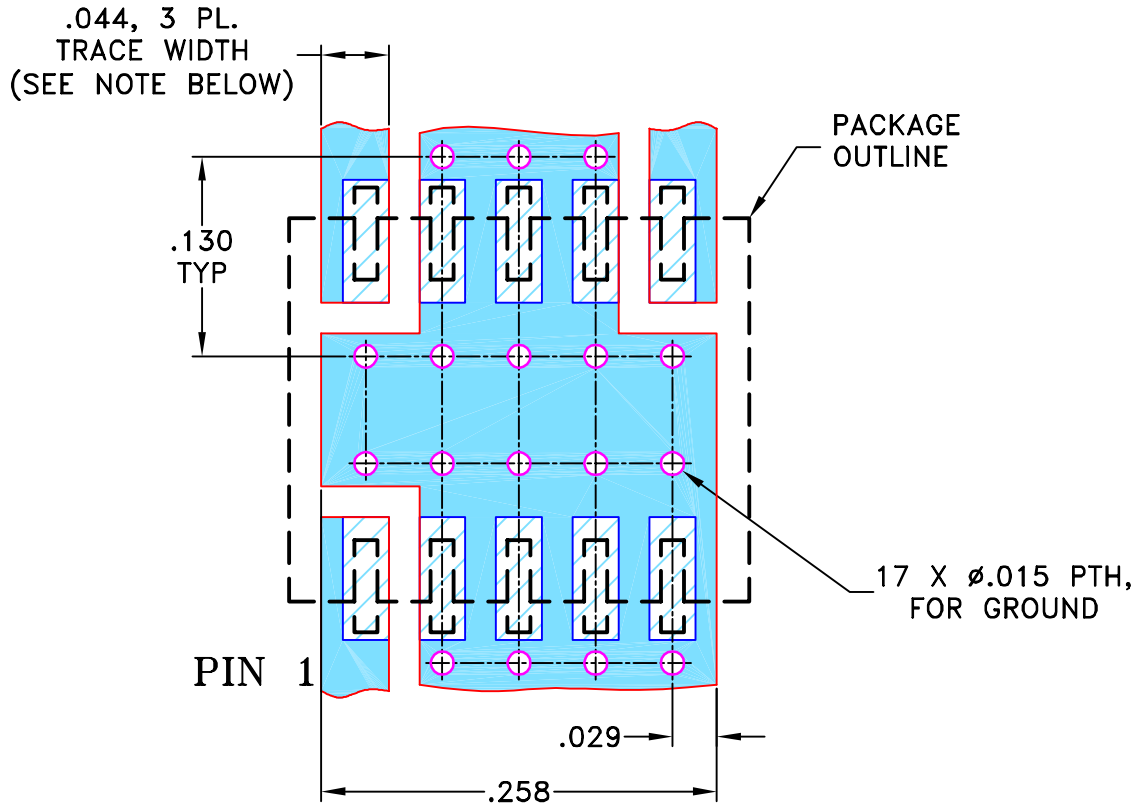

NOTES: 1. TRACE WIDTH IS SHOWN FOR ROGERS RO4350B WITH DIELECTRIC THICKNESS 0.020" ± 0.0015"; COPPER: 1/2 OZ. EACH SIDE. FOR OTHER MATERIALS TRACE WIDTH MAY NEED TO BE MODIFIED.

2. BOTTOM SIDE OF THE PCB IS CONTINUOUS GROUND PLANE.

- DENOTES PCB COPPER LAYOUT WITH SMOBC (SOLDER MASK OVER BARE COPPER)
- DENOTES COPPER LAND PATTERN FREE OF SOLDER MASK

UNLESS OTHERWISE SPECIFIED	INITIALS		DATE
DIMENSIONS ARE IN INCHES	DRAWN	AV	07/22/02
TOLERANCES ON:	CHECKED	WL	08/02/02
2 PL DECIMALS ±	APPROVED	DJ	08/02/02
3 PL DECIMALS ± .005			
ANGLES ±			
FRACTIONS ±			

Mini-Circuits[®] 13 Neptune Avenue
Brooklyn NY 11235

PL, le, SM2, MBA, TB-74

Mini-Circuits[®]
THIS DOCUMENT AND ITS CONTENTS ARE THE PROPERTY OF MINI-CIRCUITS. EXCEPT FOR USE EXPRESSLY GRANTED, IN WRITING, TO ITS VENDORS, VENDEE AND THE UNITED STATES GOVERNMENT, MINI-CIRCUITS RESERVES ALL PROPRIETARY DESIGN, USE, MANUFACTURING AND REPRODUCTION RIGHTS THERETO. THESE CONTENTS SHALL NOT BE USED, DUPLICATED OR DISCLOSED TO ANY OUTSIDE PARTY, IN WHOLE OR IN PART, WITHOUT WRITTEN PERMISSION OF MINI-CIRCUITS.

SIZE A	CODE IDENT 15542	DRAWING NO: 98-PL-067	REV: A
FILE: 98PL067	SCALE: 8:1	SHEET: 1 OF 1	

Evaluation Board and Circuit

For Pin Connections refer to Data Sheet of the DUT

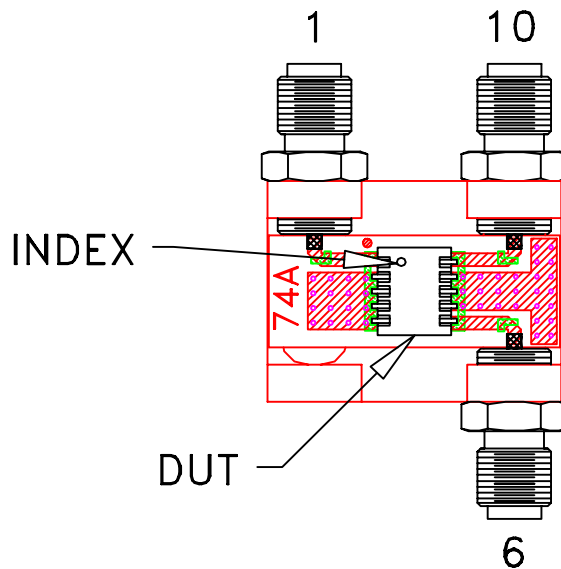

TB-74

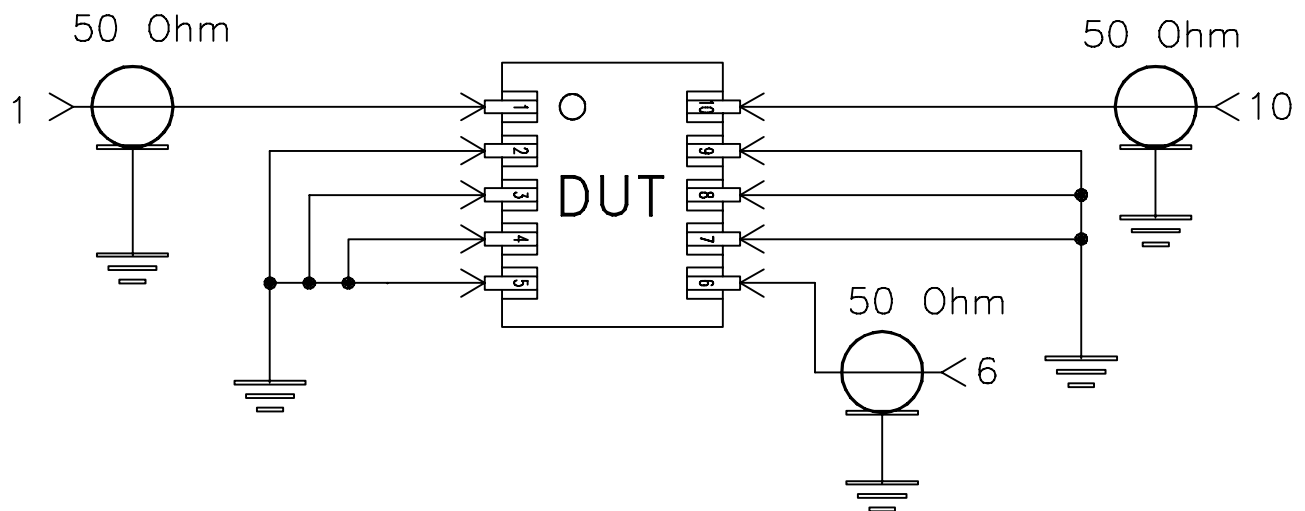

Schematic Diagram

Notes:

1. SMA Female connectors.
2. PCB Material: Rogers R04350 or equivalent,
Dielectric Constant=3.5, Thickness=.020 inch.

 Mini-Circuits®



All Mini-Circuits products are manufactured under exacting quality assurance and control standards, and are capable of meeting published specifications after being subjected to any or all of the following physical and environmental test.

Specification	Test/Inspection Condition	Reference/Spec
Operating Temperature	-40° to 85°C Ambient Environment	Individual Model Data Sheet
Storage Temperature	-55° to 100° C Ambient Environment	Individual Model Data Sheet
Humidity	90 to 95% RH, 240 hours, 50°C	MIL-STD-202, Method 103, Condition A, Except 50°C and end-point electrical test done within 12 hours
Thermal Shock	-55° to 100°C, 100 cycles	MIL-STD-202, Method 107, Condition A-3, except +100°C
Solder Reflow Heat	Sn-Pb Eutetic Process: 225°C peak Pb-Free Process 245° - 250°C peak	J-STD-020, Table 4-1, 4-2 and 5-2, Figure 5-1
Solderability	10X Magnification	J-STD-002, 95% Coverage
Vibration (High Frequency)	20g peak, 10-2000 Hz, 12 times in each of three perpendicular directions (total 36)	MIL-STD-202, Method 204, Condition D
Mechanical Shock	50g, 11 ms, 1/2-sine, 18 shocks: 3 each direction, each of 3 axes	MIL-STD-202, Method 213, Condition A
Marking Resistance to Solvents	Isopropyl alcohol + mineral spirits at 25°C; terpene defluxer at 25°C; distilled water + proylene glycol monomethyl ether + monoethanolamine at 63°C to 70°C	MIL-STD-202, Method 215