

# X2 Frequency Multiplier

## KBA-20+

50Ω Output 3200 to 4400 MHz



Generic photo used for illustration purposes only  
CASE STYLE: SM2

### Maximum Ratings

Operating Temperature	-40°C to 85°C
Storage Temperature	-55°C to 100°C
RF Input Power	200mW

Permanent damage may occur if any of these limits are exceeded.

### Pin Connections

INPUT	10
OUTPUT	5
SAMPLE*	3
GROUND	1,2,4,6,7,8,9

\* Sample port output power, -10 dBc typ.  
Terminate in 50 ohms if not used.

### Outline Drawing

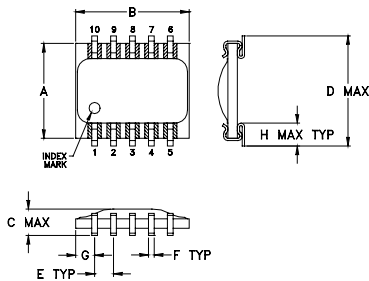

### PCB Land Pattern

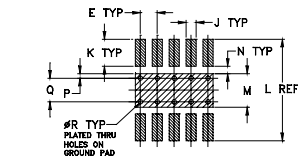

Suggested Layout,  
Tolerance to be within ±0.02  
ADJACENT GROUND PINS SHALL BE CONNECTED TO EACH OTHER AND TO GROUND PAD

### Outline Dimensions (inch/mm)

A	B	C	D	E	F	G	H	
.250	.300	.095	.290	.050	.015	.050	.060	
6.35	7.62	2.41	7.37	1.27	0.38	1.27	1.52	
J	K	L	M	N	P	Q	R	wt
.030	.080	.300	.100	.020	.015	.070	.014	grams
0.76	2.03	7.62	2.54	0.51	0.38	1.78	0.36	0.3

### Demo Board MCL P/N: TB-99 Suggested PCB Layout (PL-066)

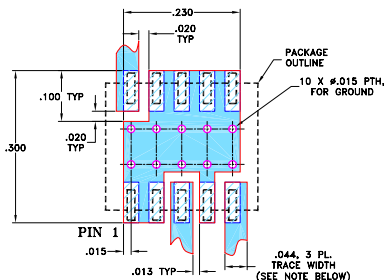

- NOTES: 1. TRACE WIDTH IS SHOWN FOR ROGERS RO4350B WITH DIELECTRIC THICKNESS 0.020" ± 0.0015". COPPER: 1/2 OZ., EACH SIDE. FOR OTHER MATERIALS TRACE WIDTH MAY NEED TO BE MODIFIED.  
2. BOTTOM SIDE OF THE PCB IS CONTINUOUS GROUND PLANE.  
DENOTES PCB COPPER LAYOUT WITH SMOBC (SOLDER MASK OVER BARE COPPER)  
DENOTES COPPER LAND PATTERN FREE OF SOLDER MASK

### Notes

- A. Performance and quality attributes and conditions not expressly stated in this specification document are intended to be excluded and do not form a part of this specification document.  
B. Electrical specifications and performance data contained in this specification document are based on Mini-Circuit's applicable established test performance criteria and measurement instructions.  
C. The parts covered by this specification document are subject to Mini-Circuits standard limited warranty and terms and conditions (collectively, "Standard Terms"); Purchasers of this part are entitled to the rights and benefits contained therein. For a full statement of the Standard Terms and the exclusive rights and remedies thereunder, please visit Mini-Circuits' website at [www.minicircuits.com/MCLStore/terms.jsp](http://www.minicircuits.com/MCLStore/terms.jsp)

### Features

- low conversion loss, 12 dB typ.
- low profile, 0.070" max.
- aqueous washable
- protected by US patent 5,534,830

### Applications

- synthesizers
- local oscillators

### Electrical Specifications

MULTIPLICATION FACTOR	FREQUENCY (MHz)		INPUT POWER (dBm)		CONVERSION LOSS (dB)		*HARMONIC OUTPUT (dBc)					
	F1 Input	F2 Output	Min.	Max.	Typ.	Max.	F1		F3		F4	
							Typ.	Min.	Typ.	Min.	Typ.	Min.
2	1600-2200	3200-4400	11	15	12	15.8	12	7	20	13	23	10

\* Harmonics of input frequency below the power level of F2

### Typical Performance Data 25°C

Input Frequency (MHz)	Conversion Loss (dB)	Harmonic Output (-dBc)		
		F1	F3	F4
1600.00	12.49	10.21	23.69	22.41
1700.00	12.07	11.36	22.56	24.44
1750.00	11.92	11.20	22.00	22.24
1800.00	11.70	12.27	23.75	22.35
1850.00	11.55	12.67	24.11	22.75
1900.00	11.38	13.23	23.71	21.07
1950.00	11.55	14.25	24.05	20.49
2000.00	11.60	14.11	22.15	18.03
2100.00	11.56	13.51	21.61	15.05
2200.00	11.74	11.80	23.02	14.68

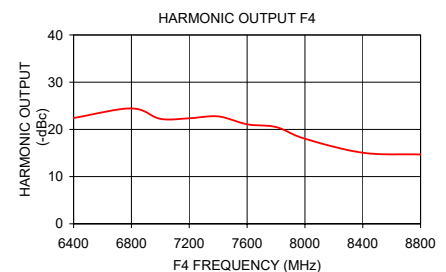
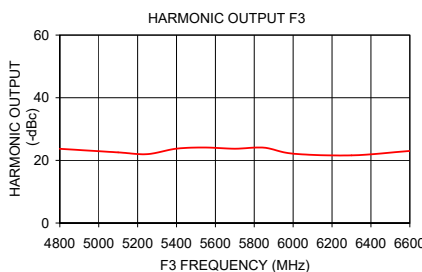
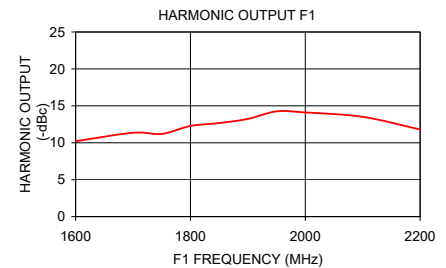
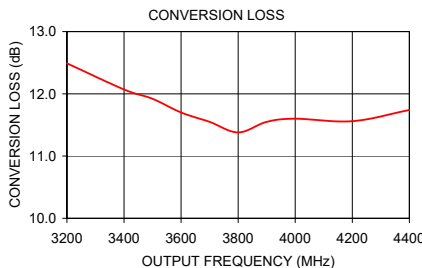

# Frequency Multiplier (Doublers)

# KBA-20+

## Typical Performance Data

FREQUENCY (MHz)				CONVERSION LOSS (dB)	HARMONIC OUTPUT*		
X 1 OUTPUT	X 2 OUTPUT	X 3 OUTPUT	X 4 OUTPUT	X 2 OUTPUT	X 1 OUTPUT	X 3 OUTPUT	X 4 OUTPUT
1600	3200	4800	6400	12.49	10.21	23.69	22.41
1700	3400	5100	6800	12.07	11.36	22.56	24.44
1750	3500	5250	7000	11.92	11.20	22.00	22.24
1800	3600	5400	7200	11.70	12.27	23.75	22.35
1850	3700	5550	7400	11.55	12.67	24.11	22.75
1900	3800	5700	7600	11.38	13.23	23.71	21.07
1950	3900	5850	7800	11.55	14.25	24.05	20.49
2000	4000	6000	8000	11.60	14.11	22.15	18.03
2100	4200	6300	8400	11.56	13.51	21.61	15.05
2200	4400	6600	8800	11.74	11.80	23.02	14.68

\*Harmonic Output below power level of X 2 Output .

# Frequency Multiplier (Doubler)

KBA-20+

## Typical Performance Curves

Conversion Loss X 2 Output

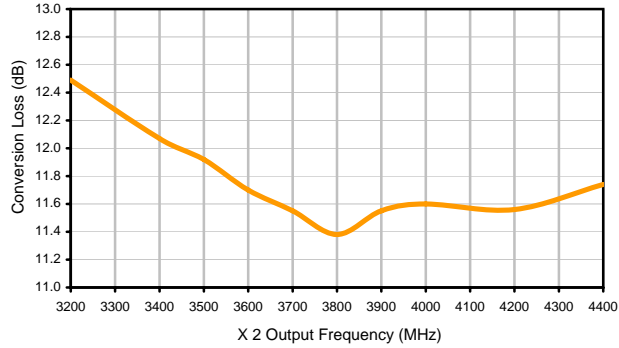

Harmonic X 1 Output

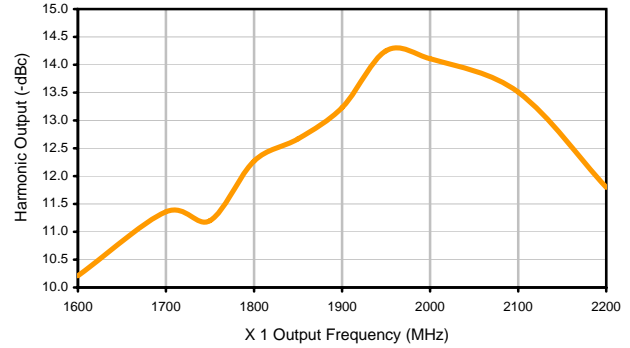

Harmonic X 3 Output

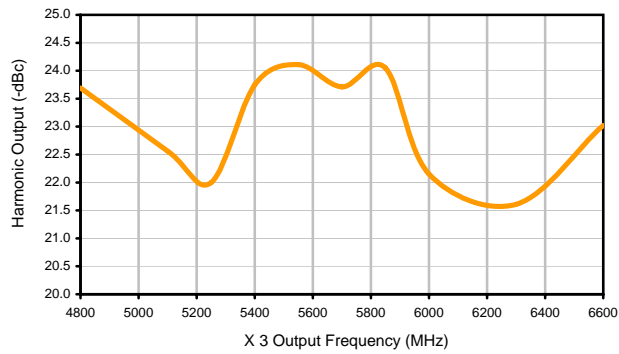

Harmonic X 4 Output

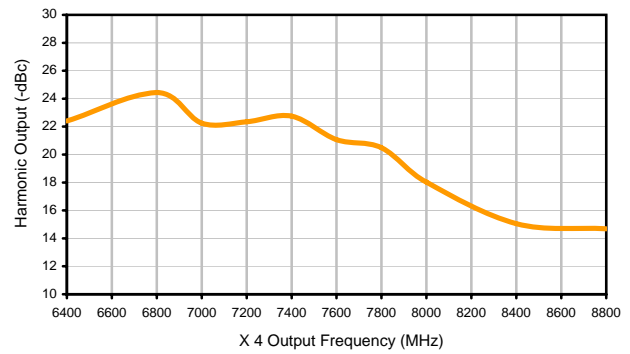

# Case Style

# SM2

SM2

## Outline Dimensions

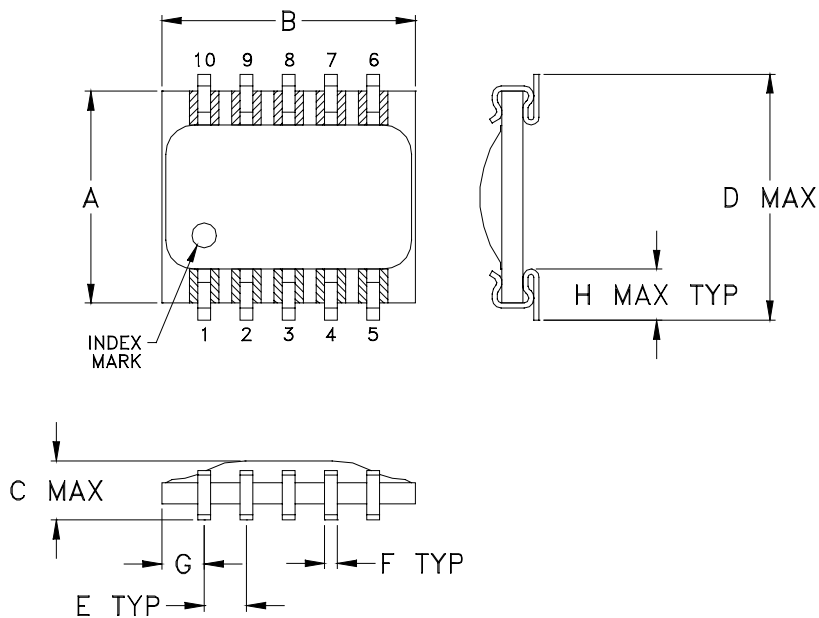

## PCB Land Pattern

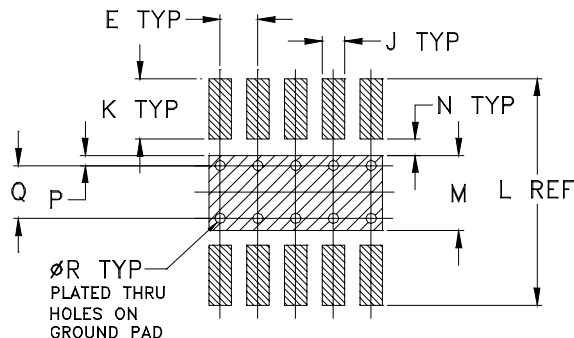

Suggested Layout,  
Tolerance to be within  $\pm 0.002$

ADJACENT GROUND PINS SHALL BE CONNECTED  
TO EACH OTHER AND TO GROUND PAD

CASE #	A	B	C	D	E	F	G	H	J	K	L	M	N	P
SM2	.250 (6.35)	.300 (7.62)	.095 (2.41)	.290 (7.37)	.050 (1.27)	.015 (0.38)	.050 (1.27)	.060 (1.52)	.030 (0.76)	.080 (2.03)	.300 (7.62)	.100 (2.54)	.020 (0.51)	.015 (0.38)

CASE #	Q	R	WT. GRAM
SM2	.070 (1.78)	.014 (0.36)	.3

Dimensions are in inches (mm). Tolerances:  $\pm .005$

### Notes:

1. Case material: Plastic encapsulation on Ceramic base.
2. Termination finish:  
For RoHS Case Styles: Tin plate over Nickel plate.  
For RoHS-5 Case Styles: Tin-Lead plate.



INTERNET <http://www.minicircuits.com>

P.O. Box 350166, Brooklyn, New York 11235-0003 (718) 934-4500 Fax (718) 332-4661

Distribution Centers NORTH AMERICA 800-654-7949 • 417-335-5935 • Fax 417-335-5945 • EUROPE 44-1252-832600 • Fax 44-1252-837010

Mini-Circuits ISO 9001 & ISO 14001 Certified

# Tape & Reel Packaging TR-F34



Tape Width, mm	Device Cavity Pitch, mm	Reel Size, inches	Devices per Reel see note	
16	12	7	Small quantity standard (see note)	20
				50
			100	
			200	
		13	Standard	500
				1000

Note: Availability of small reel quantity varies by model.  
Refer to pricing and availability on individual model dashboard.

Mini-Circuits carrier tape materials provide protection from ESD (Electro-Static Discharge) during handling and transportation. Tapes are static dissipative and comply with industry standards EIA-481/EIA-541.

Go to: [www.minicircuits.com/pages/pdfs/tape.pdf](http://www.minicircuits.com/pages/pdfs/tape.pdf)



INTERNET <http://www.minicircuits.com>

P.O. Box 350166, Brooklyn, New York 11235-0003 (718) 934-4500 Fax (718) 332-4661

Distribution Centers NORTH AMERICA 800-654-7949 • 417-335-5935 • Fax 417-335-5945 • EUROPE 44-1252-832600 • Fax 44-1252-837010

Mini-Circuits ISO 9001 & ISO 14001 Certified

THIRD ANGLE PROJECTION

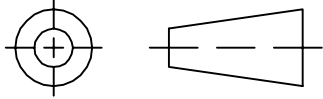

REVISIONS

REV	ECN No.	DESCRIPTION	DATE	DR	AUTH
OR	M82272	NEW RELEASE	08/02/02	GF	DJ
A	M102713	UPDATED NOTES, ADDED "...WITH SMOBC"	01/16/06	GT	IL

SUGGESTED MOUNTING CONFIGURATION FOR SM2 CASE STYLE, "Id" PIN CONNECTION

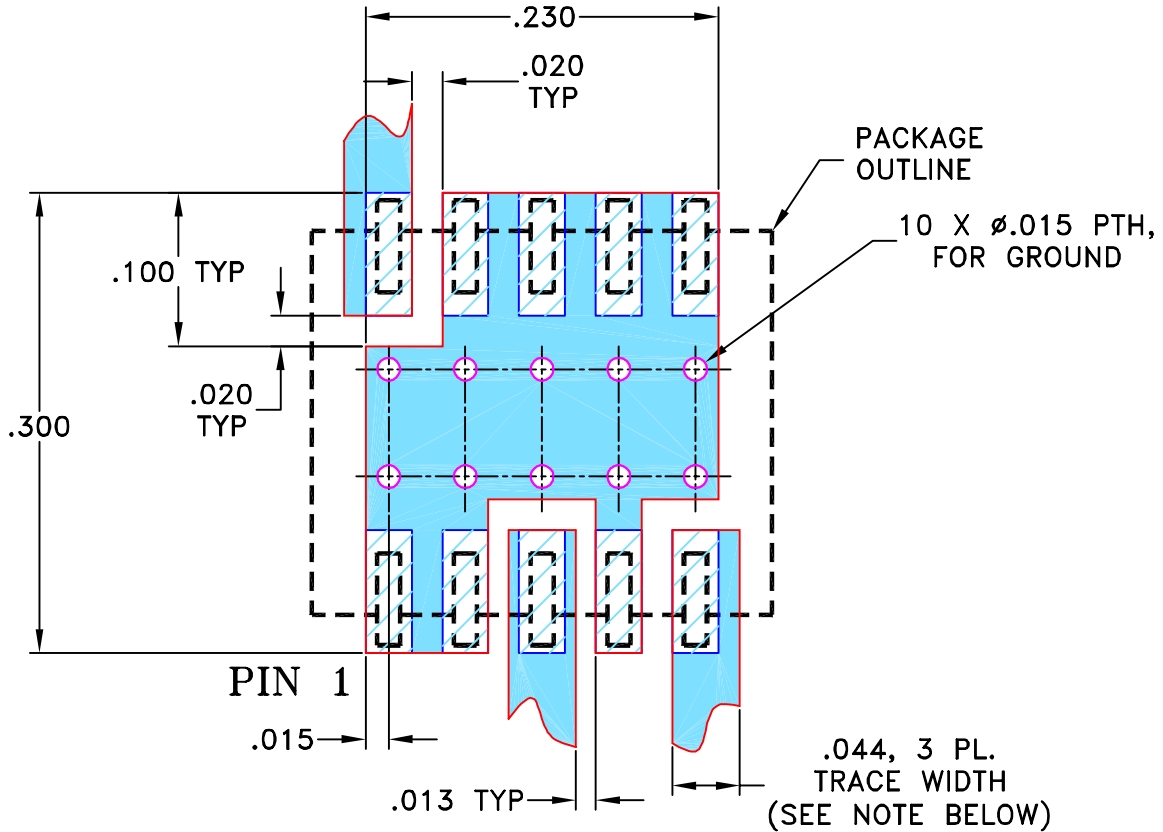

- NOTES: 1. TRACE WIDTH IS SHOWN FOR ROGERS R04350B WITH DIELECTRIC THICKNESS 0.020" ± 0.0015". COPPER: 1/2 OZ. EACH SIDE. FOR OTHER MATERIALS TRACE WIDTH MAY NEED TO BE MODIFIED.

2. BOTTOM SIDE OF THE PCB IS CONTINUOUS GROUND PLANE.

 DENOTES PCB COPPER LAYOUT WITH SMOBC (SOLDER MASK OVER BARE COPPER)

 DENOTES COPPER LAND PATTERN FREE OF SOLDER MASK

UNLESS OTHERWISE SPECIFIED	INITIALS	DATE
DIMENSIONS ARE IN INCHES	DRAWN GF	07/18/02
TOLERANCES ON:	CHECKED WL	08/02/02
2 PL DECIMALS ±	APPROVED DJ	08/02/02
3 PL DECIMALS ± .005		
ANGLES ±		
FRACTIONS ±		

 **Mini-Circuits**<sup>®</sup> 13 Neptune Avenue  
Brooklyn NY 11235

PL, Id, SM2, MBA, TB-99

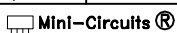
 Mini-Circuits<sup>®</sup>  
THIS DOCUMENT AND ITS CONTENTS ARE THE PROPERTY OF MINI-CIRCUITS. EXCEPT FOR USE EXPRESSLY GRANTED, IN WRITING, TO ITS VENDORS, VENDEE AND THE UNITED STATES GOVERNMENT, MINI-CIRCUITS RESERVES ALL PROPRIETARY DESIGN, USE, MANUFACTURING AND REPRODUCTION RIGHTS THERETO. THESE CONTENTS SHALL NOT BE USED, DUPLICATED OR DISCLOSED TO ANY OUTSIDE PARTY, IN WHOLE OR IN PART, WITHOUT WRITTEN PERMISSION OF MINI-CIRCUITS.

SIZE A	CODE IDENT 15542	DRAWING NO: 98-PL-066	REV: A
FILE: 98PL066	SCALE: 8:1	SHEET: 1 OF 1	

# Evaluation Board and Circuit

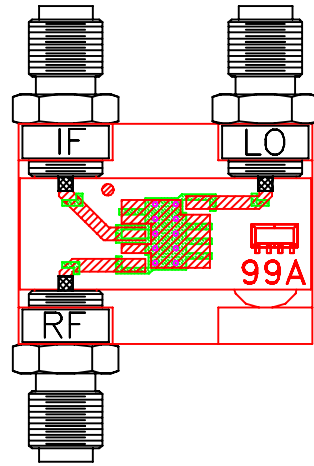

TB-99

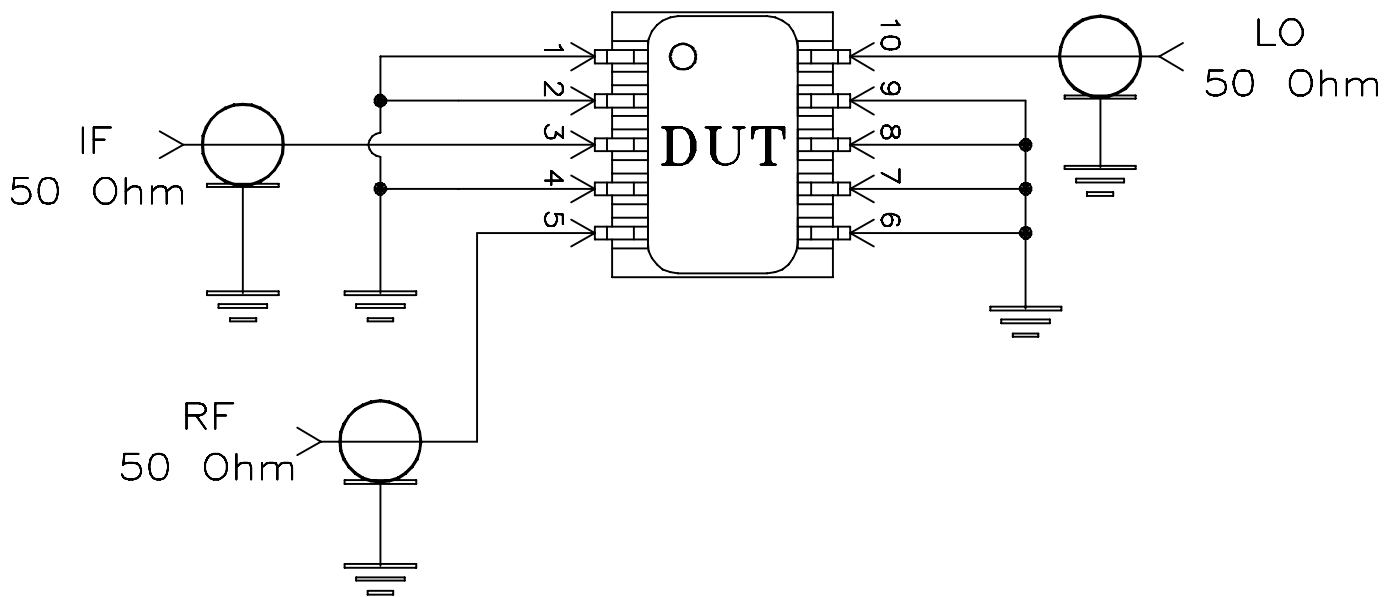

Schematic Diagram

## Notes:

1. SMA Female connectors.
2. PCB Material: Rogers R04350 or equivalent, Dielectric Constant=3.5, Thickness=.020 inch.

 Mini-Circuits®



All Mini-Circuits products are manufactured under exacting quality assurance and control standards, and are capable of meeting published specifications after being subjected to any or all of the following physical and environmental test.

Specification	Test/Inspection Condition	Reference/Spec
Operating Temperature	-40° to 85°C Ambient Environment	Individual Model Data Sheet
Storage Temperature	-55° to 100° C Ambient Environment	Individual Model Data Sheet
Humidity	90 to 95% RH, 240 hours, 50°C	MIL-STD-202, Method 103, Condition A, Except 50°C and end-point electrical test done within 12 hours
Thermal Shock	-55° to 100°C, 100 cycles	MIL-STD-202, Method 107, Condition A-3, except +100°C
Solder Reflow Heat	Sn-Pb Eutetic Process: 225°C peak Pb-Free Process 245° - 250°C peak	J-STD-020, Table 4-1, 4-2 and 5-2, Figure 5-1
Solderability	10X Magnification	J-STD-002, 95% Coverage
Vibration (High Frequency)	20g peak, 10-2000 Hz, 12 times in each of three perpendicular directions (total 36)	MIL-STD-202, Method 204, Condition D
Mechanical Shock	50g, 11 ms, 1/2-sine, 18 shocks: 3 each direction, each of 3 axes	MIL-STD-202, Method 213, Condition A
Marking Resistance to Solvents	Isopropyl alcohol + mineral spirits at 25°C; terpene defluxer at 25°C; distilled water + proylene glycol monomethyl ether + monoethanolamine at 63°C to 70°C	MIL-STD-202, Method 215