

# NON-CATALOG

Surface Mount

# Voltage Controlled Oscillator

# JTOS-850VW+

Wide Band 400 to 850 MHz

### Features

- excellent tuning linearity
- octave bandwidth
- low phase noise, -136 dBc/Hz at 1 MHz offset, typ.
- aqueous washable

### Applications

- cellular
- UHF
- wideband frequency synthesizers



CASE STYLE: BK377

**+RoHS Compliant**  
The +Suffix identifies RoHS Compliance. See our web site for RoHS Compliance methodologies and qualifications

### Electrical Specifications

FREQUENCY (MHz)	POWER OUTPUT (dBm)	TUNING VOLTAGE (V)	PHASE NOISE (dBc/Hz)				PULLING pk-pk @ 12 dB (MHz)	PUSHING (MHz/V)	TUNING SENSITIVITY (MHz/V)	HARMONICS (dBc)	3 dB MODULATION BANDWIDTH (MHz)	DC OPERATING POWER	
			SSB at offset frequencies: Typ.									Vcc (volts)	Current (mA) Max.
Min.	Max.	Typ.	Min.	Max.	1 kHz	10 kHz	100 kHz	1 MHz	Typ.	Typ.	Typ.	5	20
400	850	+6.0	0.5	18	-74	-96	-116	-136	6.0	1.5	15-80	-20	0.185

### Pin Connections

RF OUT	13
VCC	2
V-TUNE	5
GROUND	1,3,4,6,7,8,9,10,11,12,14

### Maximum Ratings

Operating Temperature	-55°C to 85°C
Storage Temperature	-55°C to 100°C
Absolute Max. Supply Voltage (Vcc)	6V
Absolute Max. Tuning Voltage (Vtune)	20V
All specifications	50 ohm system

Permanent damage may occur if any of these limits are exceeded.

### Tape & Reel: F107

7" Reels with 10, 20, 50, 100 devices  
13" Reels with 200 devices

### Environmental Ratings: ENV65

### Outline Drawing

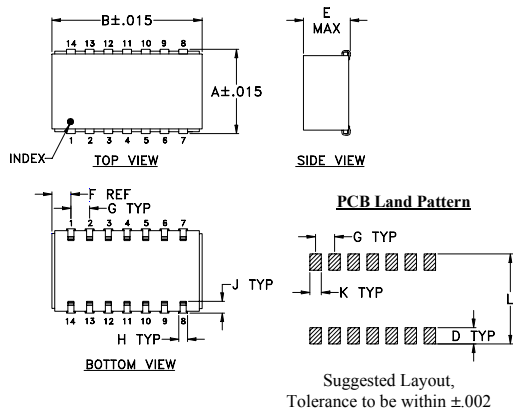

### Demo Board MCL PIN: TB-04 Suggested PCB Layout (PL-005)

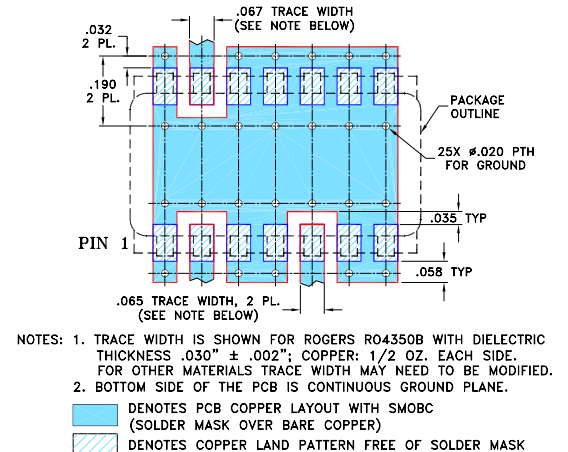

### Outline Dimensions (inch/mm)

A	B	C	D	E	F	G	H	J	K	L	wt
.505	.800	--	.100	.250	.100	.100	.047	.065	.065	.525	grams
12.83	20.32	--	2.54	6.35	2.54	2.54	1.19	1.65	1.65	13.34	3.0

### Notes

- Performance and quality attributes and conditions not expressly stated in this specification document are intended to be excluded and do not form a part of this specification document.
- Electrical specifications and performance data contained in this specification document are based on Mini-Circuit's applicable established test performance criteria and measurement instructions.
- The parts covered by this specification document are subject to Mini-Circuits standard limited warranty and terms and conditions (collectively, "Standard Terms"); Purchasers of this part are entitled to the rights and benefits contained therein. For a full statement of the Standard Terms and the exclusive rights and remedies thereunder, please visit Mini-Circuits' website at [www.minicircuits.com/VCLStore/terms.jsp](http://www.minicircuits.com/VCLStore/terms.jsp)



# NON-CATALOG

## Performance Data & Curves

## JTOS-850VW+

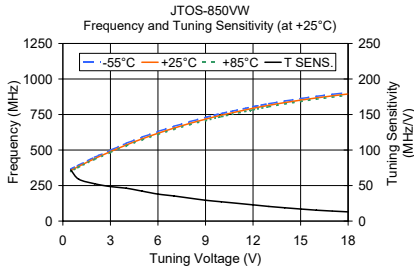

V TUNE	TUNING SENS. (MHz/V)	FREQUENCY (MHz)			POWER OUTPUT (dBm)		
		-55°C	+25°C	+85°C	-55°C	+25°C	+85°C
0.50	71.96	366.38	355.68	349.01	6.00	6.52	5.37
1.00	58.97	393.77	385.16	380.30	5.24	6.07	5.34
2.00	52.59	448.83	439.44	433.98	4.64	5.38	4.99
3.00	48.53	498.80	488.55	482.39	5.81	6.43	6.05
4.00	46.26	547.11	535.62	528.32	6.49	7.09	6.84
5.00	42.18	591.08	578.72	570.49	6.24	7.01	6.98
6.00	37.97	630.57	617.97	609.06	7.12	7.56	7.20
7.00	35.42	666.84	654.03	644.73	8.04	8.54	8.08
8.00	32.27	699.80	687.10	677.50	8.69	9.13	8.56
9.00	29.33	729.67	717.14	707.32	8.50	9.37	8.97
10.00	27.12	757.01	744.77	734.76	7.94	8.87	8.64
12.00	22.79	805.03	793.55	783.42	7.33	8.27	7.93
13.00	20.60	826.02	814.71	804.69	7.01	8.02	7.77
14.00	18.71	845.12	833.90	823.95	6.79	7.78	7.56
15.00	16.94	862.40	851.26	841.51	6.66	7.60	7.39
16.00	15.37	878.01	866.99	857.49	6.44	7.48	7.30
17.00	14.11	892.15	881.42	872.10	6.05	7.23	7.21
18.00	12.92	905.11	894.66	885.40	5.51	6.82	6.96

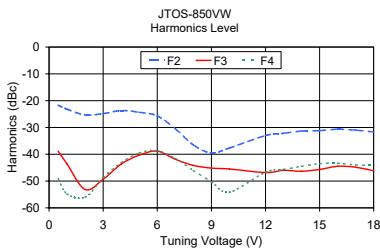
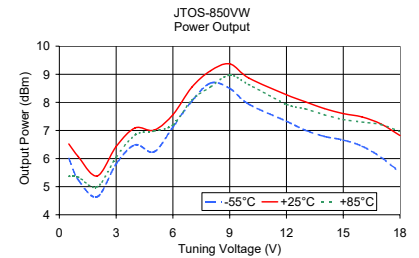

V TUNE	HARMONICS (dBc)			FREQ. PUSHING (MHz/V)
	F2	F3	F4	
0.50	-21.66	-38.83	-49.16	1.35
1.00	-23.17	-43.67	-54.84	2.51
2.00	-25.33	-53.17	-56.00	1.17
3.00	-24.84	-49.34	-48.84	0.91
4.00	-23.67	-43.67	-43.17	0.38
5.00	-24.33	-40.33	-39.50	0.25
6.00	-25.67	-38.84	-38.67	0.27
7.00	-30.50	-41.84	-41.50	0.53
8.00	-36.50	-44.17	-46.00	0.84
9.00	-39.50	-45.17	-50.34	1.06
10.00	-37.67	-45.50	-54.17	1.40
12.00	-33.00	-46.83	-46.67	2.06
13.00	-32.17	-46.00	-45.67	2.36
14.00	-31.34	-46.34	-44.50	2.64
15.00	-31.16	-45.66	-43.50	2.91
16.00	-30.67	-44.50	-43.33	2.99
17.00	-31.00	-44.84	-44.00	2.98
18.00	-31.67	-46.17	-44.17	2.92

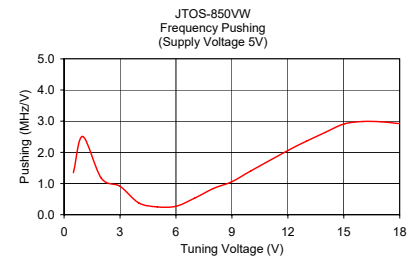

### Notes

- Performance and quality attributes and conditions not expressly stated in this specification document are intended to be excluded and do not form a part of this specification document.
- Electrical specifications and performance data contained in this specification document are based on Mini-Circuit's applicable established test performance criteria and measurement instructions.
- The parts covered by this specification document are subject to Mini-Circuits standard limited warranty and terms and conditions (collectively, "Standard Terms"); Purchasers of this part are entitled to the rights and benefits contained therein. For a full statement of the Standard Terms and the exclusive rights and remedies thereunder, please visit Mini-Circuits' website at [www.minicircuits.com/MCLStore/terms.jsp](http://www.minicircuits.com/MCLStore/terms.jsp)



# Voltage Controlled Oscillator

JTOS-850VW+

## Typical Performance Data

V TUNE	TUNE SENS (MHz/V)	FREQUENCY (MHz)			POWER OUTPUT (dBm)			HARMONICS (dBc)			FREQ. PUSH (MHz/V)	FREQ OFFSET (KHz)	PHASE NOISE (dBc/Hz)
		-55°C	+25°C	+85°C	-55°C	+25°C	+85°C	F2	F3	F4			
0.5	71.96	366.4	355.7	349.0	6.00	6.52	5.37	-21.7	-38.8	-49.2	1.35	1	-74
1.0	58.97	393.8	385.2	380.3	5.24	6.07	5.34	-23.2	-43.7	-54.8	2.51	10	-96
2.0	52.59	448.8	439.4	434.0	4.64	5.38	4.99	-25.3	-53.2	-56.0	1.17	100	-116
3.0	48.53	498.8	488.6	482.4	5.81	6.43	6.05	-24.8	-49.3	-48.8	0.91	1000	-136
4.0	46.26	547.1	535.6	528.3	6.49	7.09	6.84	-23.7	-43.7	-43.2	0.38		
5.0	42.18	591.1	578.7	570.5	6.24	7.01	6.98	-24.3	-40.3	-39.5	0.25		
6.0	37.97	630.6	618.0	609.1	7.12	7.56	7.20	-25.7	-38.8	-38.7	0.27		
7.0	35.42	666.8	654.0	644.7	8.04	8.54	8.08	-30.5	-41.8	-41.5	0.53		
8.0	32.27	699.8	687.1	677.5	8.69	9.13	8.56	-36.5	-44.2	-46.0	0.84		
9.0	29.33	729.7	717.1	707.3	8.50	9.37	8.97	-39.5	-45.2	-50.3	1.06		
10.0	27.12	757.0	744.8	734.8	7.94	8.87	8.64	-37.7	-45.5	-54.2	1.40		
12.0	22.79	805.0	793.6	783.4	7.33	8.27	7.93	-33.0	-46.8	-46.7	2.06		
13.0	20.60	826.0	814.7	804.7	7.01	8.02	7.77	-32.2	-46.0	-45.7	2.36		
14.0	18.71	845.1	833.9	824.0	6.79	7.78	7.56	-31.3	-46.3	-44.5	2.64		
15.0	16.94	862.4	851.3	841.5	6.66	7.60	7.39	-31.2	-45.7	-43.5	2.91		
16.0	15.37	878.0	867.0	857.5	6.44	7.48	7.30	-30.7	-44.5	-43.3	2.99		
17.0	14.11	892.2	881.4	872.1	6.05	7.23	7.21	-31.0	-44.8	-44.0	2.98		
18.0	12.92	905.1	894.7	885.4	5.51	6.82	6.96	-31.7	-46.2	-44.2	2.92		

REV. X1  
JTOS-850VW+  
070131  
Page 1 of 1



IF/RF MICROWAVE COMPONENTS • ISO 9001 ISO 14001 AS 9100 CERTIFIED • RoHS compliant  
P.O. Box 350166, Brooklyn, New York 11235-0003 (718) 934-4500 Fax (718) 332-4661



The Design Engineers Search Engine finds the model you need, Instantly • For detailed performance specs & shopping online see



# Voltage Controlled Oscillator

# JTOS-850VW+

## Typical Performance Data

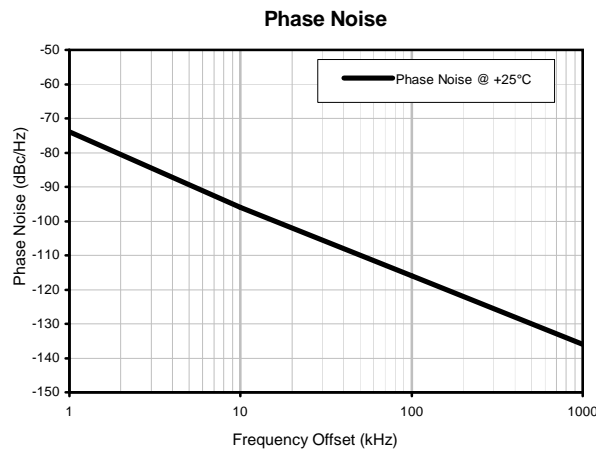
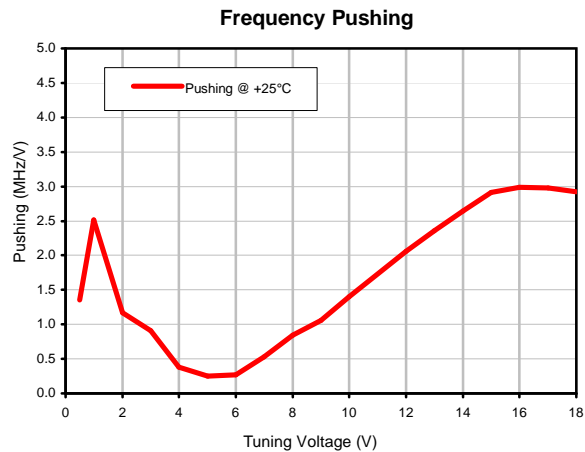
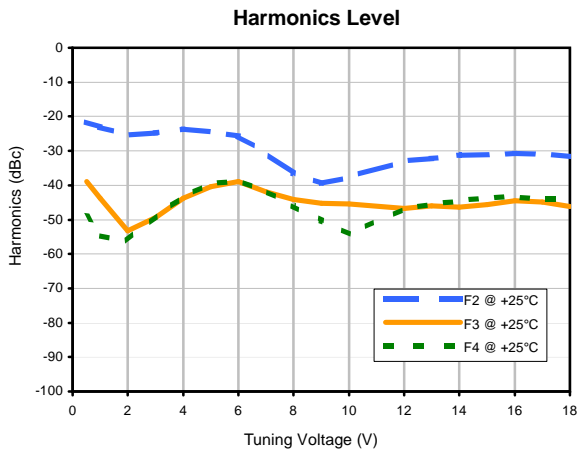
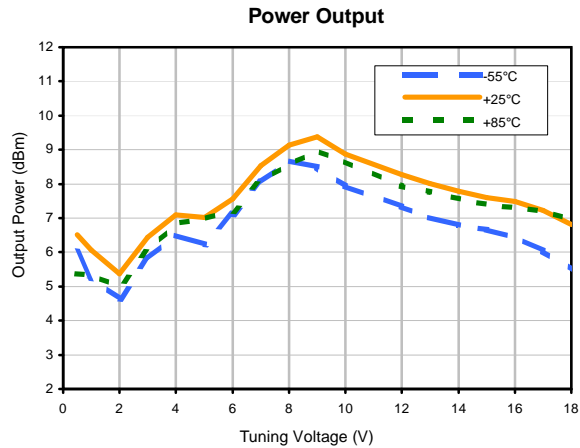
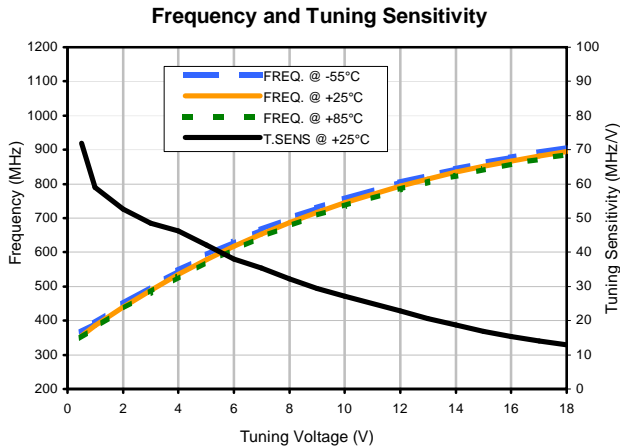

### Outline Dimensions

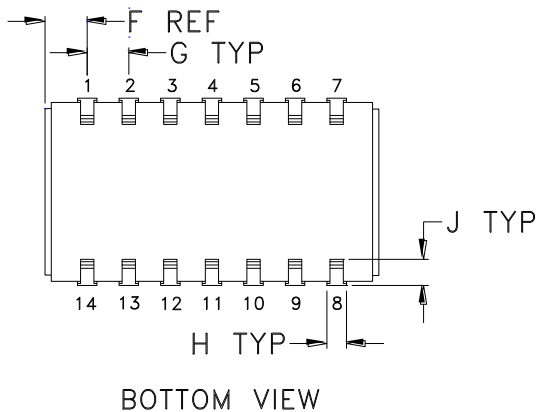
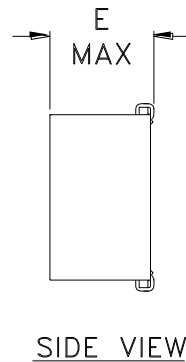
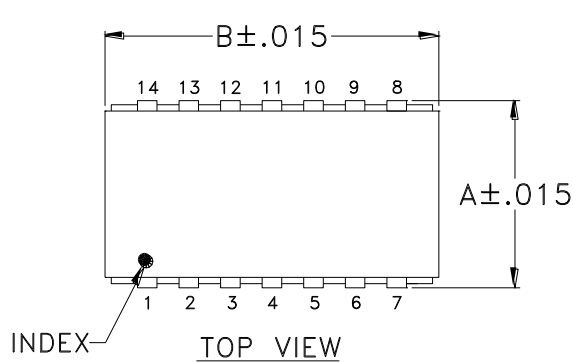

### PCB Land Pattern

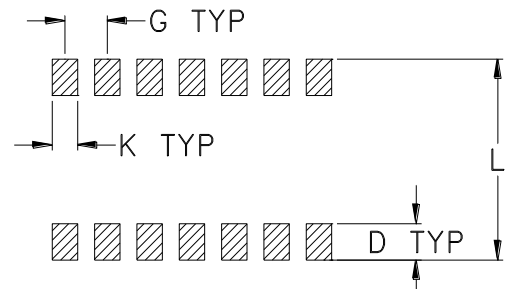

Suggested Layout,  
Tolerance to be within  $\pm .002$

CASE #	A	B	C	D	E	F	G	H	J	K	L	WT. GRAM
BK377	.505 (12.83)	.800 (20.32)	-- --	.100 (2.54)	.250 (6.35)	.100 (2.54)	.100 (2.54)	.047 (1.19)	.065 (1.65)	.065 (1.65)	.525 (13.34)	2.0 MAX.

Dimensions are in inches (mm). Tolerances: 2Pl.  $\pm .01$ ; 3Pl.  $\pm .005$

#### Notes:

- Case material: Copper Nickel alloy.
- Base material: Printed wiring laminate.
- Termination finish:
  - For RoHS Case Styles: Tin plate over Nickel plate. All models, (+) suffix.
  - For RoHS-5 Case Styles: Tin-Lead plate. All models, no (+) suffix.



Distribution Centers NORTH AMERICA 800-654-7949 • 417-335-5935 • Fax 417-335-5945 • EUROPE 44-1252-832600 • Fax 44-1252-837010

Mini-Circuits ISO 9001 & ISO 14001 Certified

INTERNET <http://www.minicircuits.com>

P.O. Box 350166, Brooklyn, New York 11235-0003 (718) 934-4500 Fax (718) 332-4661

# Tape & Reel Packaging TR-F107

## DEVICE ORIENTATION IN T&R

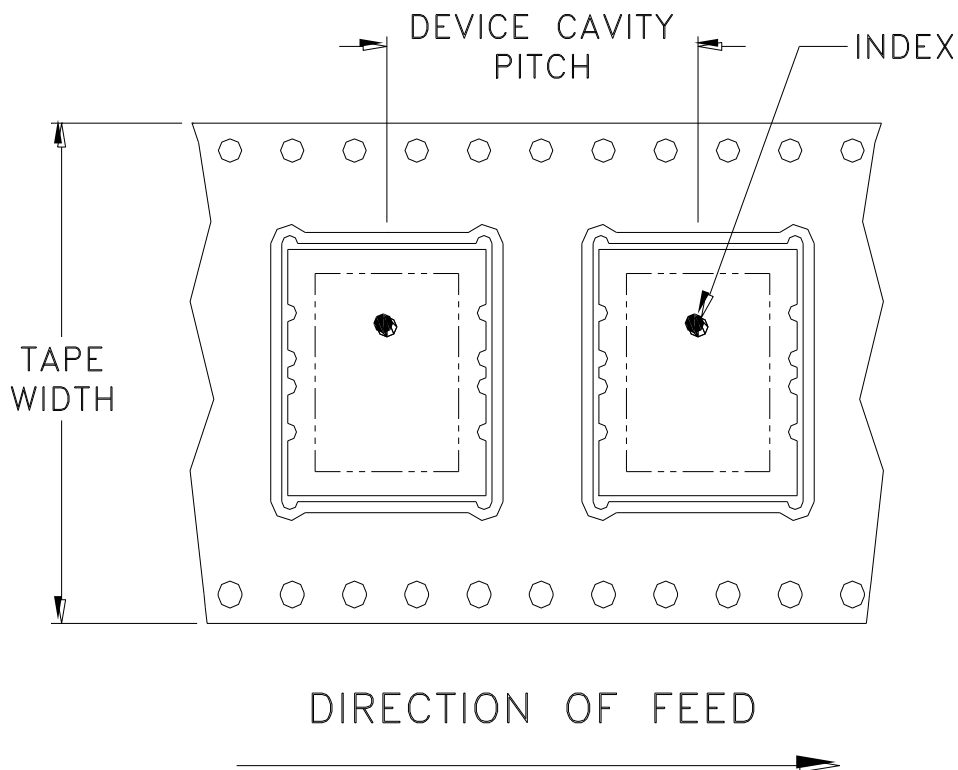

Tape Width, mm	Device Cavity Pitch, mm	Reel Size, inches	Devices per Reel	
32	20	7	Small quantity standards (see note)	10
				20
				50
		13	Standard	100
			Standard	200

Note: Please consult individual model data sheet to determine device per reel availability.

Mini-Circuits carrier tape materials provide protection from ESD (Electro-Static Discharge) during handling and transportation. Tapes are static dissipative and comply with industry standards EIA-481/EIA-541.

Go to: [www.minicircuits.com/pages/pdfs/tape.pdf](http://www.minicircuits.com/pages/pdfs/tape.pdf)

**Mini-Circuits®**

Distribution Centers NORTH AMERICA 800-654-7949 • 417-335-5935 • Fax 417-335-5945 • EUROPE 44-1252-832600 • Fax 44-1252-837010

Mini-Circuits ISO 9001 & ISO 14001 Certified

INTERNET <http://www.minicircuits.com>

P.O. Box 350166, Brooklyn, New York 11235-0003 (718) 934-4500 Fax (718) 332-4661

THIRD ANGLE PROJECTION

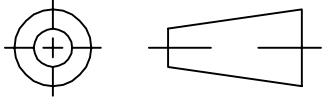

REVISIONS

REV	ECN No.	DESCRIPTION	DATE	DR	AUTH
B	M76077	UPDATED DRAWING	04/01	GF	MM
C	M82575	UPDATED DRAWING	08/08/02	IL	MM
D	M102713	UPDATED DIMENSIONS & NOTES	01/17/06	MMG	IL
E	M115059	CORRECTED NOTE 2	12/18/07	MMG	IL

SUGGESTED MOUNTING CONFIGURATION FOR BK377 CASE STYLE, "jc" PIN CONNECTION

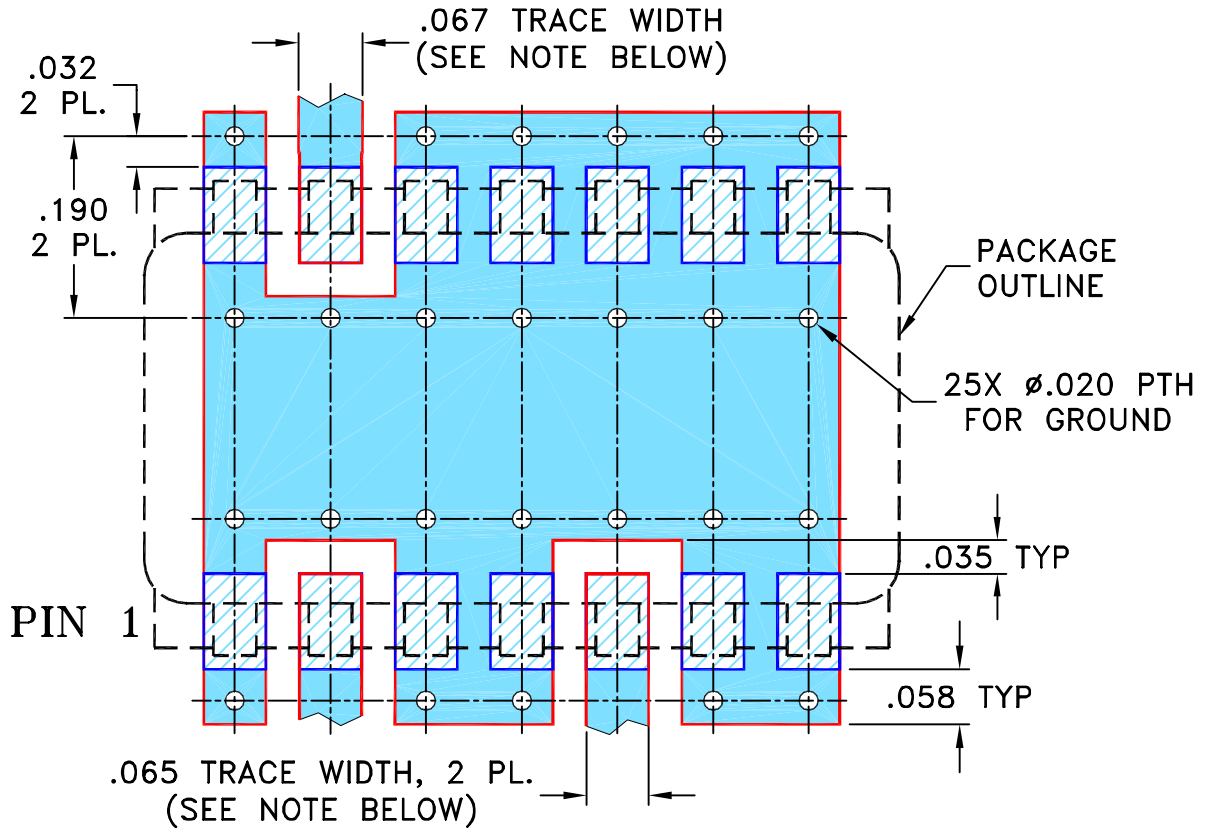

- NOTES: 1. TRACE WIDTH IS SHOWN FOR ROGERS RO4350B WITH DIELECTRIC THICKNESS .030" ± .002"; COPPER: 1/2 OZ. EACH SIDE. FOR OTHER MATERIALS TRACE WIDTH MAY NEED TO BE MODIFIED.  
 2. BOTTOM SIDE OF THE PCB IS CONTINUOUS GROUND PLANE.

- DENOTES PCB COPPER LAYOUT WITH SMOBC (SOLDER MASK OVER BARE COPPER)
- DENOTES COPPER LAND PATTERN FREE OF SOLDER MASK

UNLESS OTHERWISE SPECIFIED	INITIALS	DATE
DRAWN	FB	05/20/00
CHECKED	MM	05/24/00
APPROVED	DB	05/24/00

**Mini-Circuits®** 13 Neptune Avenue  
Brooklyn NY 11235

PL, jc, BK377, JTOS, TB-04

Mini-Circuits®  
 THIS DOCUMENT AND ITS CONTENTS ARE THE PROPERTY OF MINI-CIRCUITS. EXCEPT FOR USE EXPRESSLY GRANTED, IN WRITING, TO ITS VENDORS, VENDEE AND THE UNITED STATES GOVERNMENT, MINI-CIRCUITS RESERVES ALL PROPRIETARY DESIGN, USE, MANUFACTURING AND REPRODUCTION RIGHTS THERETO. THESE CONTENTS SHALL NOT BE USED, DUPLICATED OR DISCLOSED TO ANY OUTSIDE PARTY, IN WHOLE OR IN PART, WITHOUT WRITTEN PERMISSION OF MINI-CIRCUITS.

SIZE A	CODE IDENT 15542	DRAWING NO: 98-PL-005	REV: E
FILE: 98PL005	SCALE: 5:1	SHEET: 1 OF 1	

# Evaluation Board and Circuit

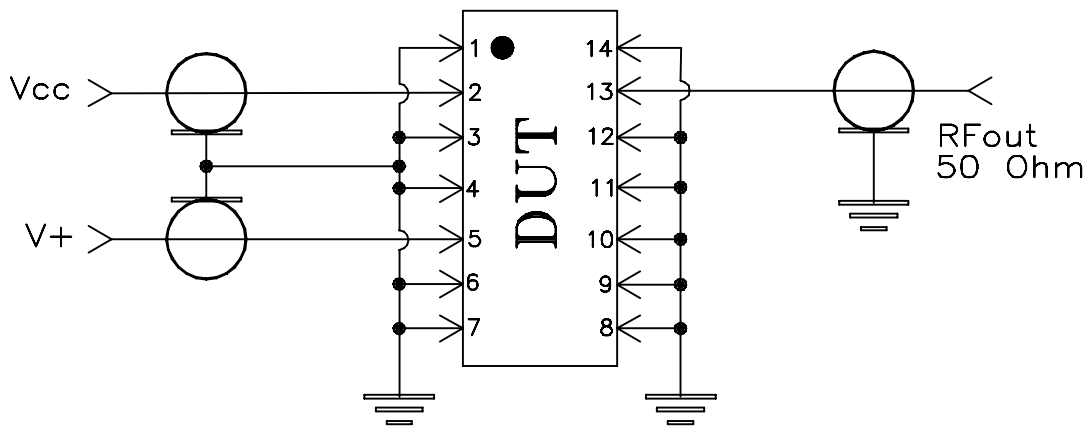
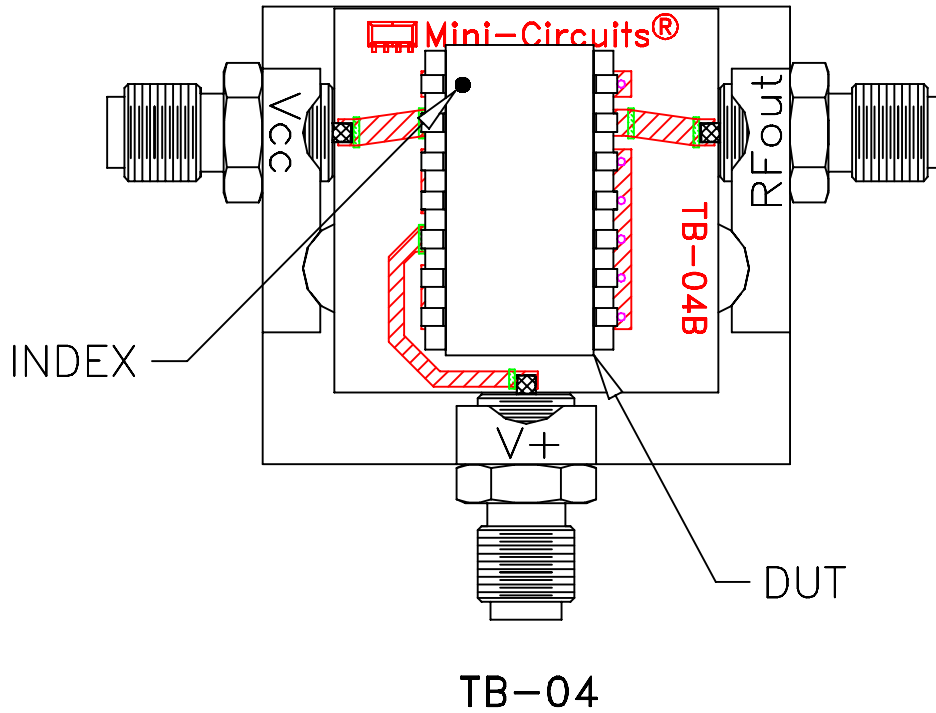

Schematic Diagram

## Notes:

1. SMA Female connectors.
2. PCB Material: Rogers R04350 or equivalent,  
Dielectric Constant=3.5, Thickness=.030 inch.

 **Mini-Circuits®**



All Mini-Circuits products are manufactured under exacting quality assurance and control standards, and are capable of meeting published specifications after being subjected to any or all of the following physical and environmental test.

Specification	Test/Inspection Condition	Reference/Spec
Operating Temperature	-55° to 85°C Ambient Environment	Individual Model Data Sheet
Storage Temperature	-55° to 100° C Ambient Environment	Individual Model Data Sheet
Humidity	90 to 95% RH, 240 hours, 50°C	MIL-STD-202, Method 103, Condition A, Except 50°C and end-point electrical test done within 12 hours
Thermal Shock	-55° to 100°C, 100 cycles	MIL-STD-202, Method 107, Condition A-3, except +100°C
Solder Reflow Heat	Sn-Pb Eutectic Process: 225°C peak Pb-Free Process, 245°C peak	J-STD-020, Table 4-1, 4-2 and 5-2, Figure 5-1
Solderability	10X Magnification	J-STD-002, Para 4.2.5, Test S, 95% Coverage
Vibration (High Frequency)	20g peak, 20-2000 Hz, 4 times in each of three axes (total 12)	MIL-STD-883, Method 2007.3, Condition A
Mechanical Shock	50g, 11 ms, 1/2-sine, 18 shocks: 3 each direction, each of 3 axes	MIL-STD-202, Method 213, Condition A
Marking Resistance to Solvents	Isopropyl alcohol + mineral spirits at 25°C; terpene defluxer at 25°C; distilled water + proylene glycol monomethyl ether + monoethanolamine at 63°C to 70°C	MIL-STD-202, Method 215