

# Surface Mount I&Q Modulator

50Ω

52 to 88 MHz

## JCIQ-88M+ JCIQ-88M



Generic photo used for illustration purposes only

CASE STYLE: BG291

**+RoHS Compliant**

The +Suffix identifies RoHS Compliance. See our web site for RoHS Compliance methodologies and qualifications

### Maximum Ratings

Operating Temperature	-55°C to 100°C
Storage Temperature	-55°C to 100°C
LO Power	50 mW
I & Q Current	40mA

Permanent damage may occur if any of these limits are exceeded.

### Pin Connections

LO (carrier)	2
RF (signal)	9
I (0°)(ref.)	4
Q (90°)*	11
GROUND	1,3,5,6,7,8,10,12,13,14

\*Q= I +90° for lower sideband suppression

### Features

- shielded metal case with J-leads
- excellent 3rd and 5th order suppression
- good carrier and sideband rejection
- aqueous washable

### Applications

- communications systems

### Modulator Electrical Specifications

FREQUENCY (MHz)				CONVERSION LOSS (dB)			CARRIER REJECTION (-dBc)		SIDE BAND REJECTION (-dBc)		HARMONIC SUPPRESSION (-dBc)					
RF (SIGNAL)		LO (CARRIER)		I&Q		$\bar{x}$	$\sigma$	Max.	Typ.	Min.	Typ.	Min.	3XI/Q		5XI/Q	
$f_L$	$f_U$	Min.	Max.	$\bar{x}$	$\sigma$								Typ.	Min.	Typ.	Min.
52	88	DC	5	5.6	0.1	7.0			40	32	35	30	45	35	65	50

1. Operating LO power: 10±1dBm
2. 1dB Compression: 0dBm typical
3. Conversion Loss: (I + Q) power, dBm - RF power, dBm
4. Carrier and sideband rejections measured at -5dBm I/Q power.

### Outline Drawing

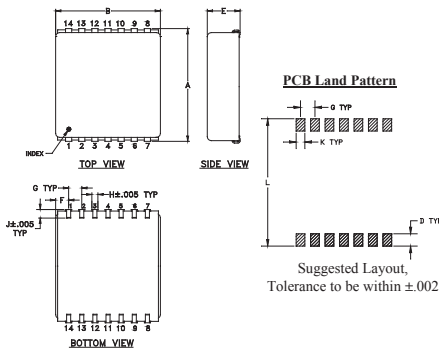

### Outline Dimensions (inch/mm)

A	B	C	D	E	F	G
.870	.800	--	.100	.250	.100	.100
22.10	20.32	--	2.54	6.35	2.54	2.54
H	J	K	L	wt		
.047	.065	.065	.890	grams		
1.19	1.65	1.65	22.61	4.0		

### Demo Board MCL P/N: TB-21 Suggested PCB Layout (PL-209)

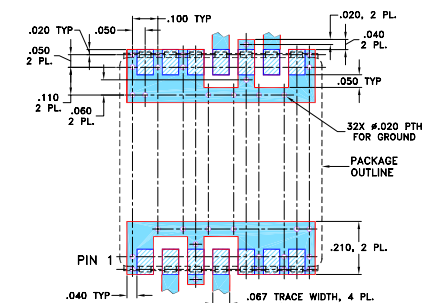

#### NOTE:

1. TRACE WIDTH IS SHOWN FOR ROGERS RO4350B WITH DIELECTRIC THICKNESS .030" ± .002"; COPPER: 1/2 OZ. EACH SIDE. FOR OTHER MATERIALS TRACE WIDTH MAY NEED TO BE MODIFIED.
2. BOTTOM SIDE OF THE PCB IS CONTINUOUS GROUND PLANE.

DENOTES PCB COPPER LAYOUT WITH SMOBC (SOLDER MASK OVER BARE COPPER)

DENOTES COPPER LAND PATTERN FREE OF SOLDER MASK

#### Notes

- A. Performance and quality attributes and conditions not expressly stated in this specification document are intended to be excluded and do not form a part of this specification document.
- B. Electrical specifications and performance data contained in this specification document are based on Mini-Circuits' applicable established test performance criteria and measurement instructions.
- C. The parts covered by this specification document are subject to Mini-Circuits standard limited warranty and terms and conditions (collectively, "Standard Terms"); Purchasers of this part are entitled to the rights and benefits contained therein. For a full statement of the Standard Terms and the exclusive rights and remedies thereunder, please visit Mini-Circuits' website at [www.minicircuits.com/MCLStore/terms.jsp](http://www.minicircuits.com/MCLStore/terms.jsp)



www.minicircuits.com P.O. Box 350166, Brooklyn, NY 11235-0003 (718) 934-4500 sales@minicircuits.com

### Typical Performance Data

Carrier Freq. (MHz)	Conversion Loss		Sideband Rejection (x)		Carrier Rejection (x)		3rd Harmonic Suppression (x)		5th Harmonic Suppression (x)		DC Offset (mV)
	$\bar{x}$ (dB)	$\sigma$ (dB)	LSB (-dBc)	USB (-dBc)	LSB (-dBc)	USB (-dBc)	LSB (-dBc)	USB (-dBc)	LSB (-dBc)	USB (-dBc)	
52.00	5.22	0.05	36.97	37.65	43.38	43.31	52.68	55.74	77.71	66.44	-0.09
53.89	5.22	0.06	37.45	38.38	43.18	43.06	52.39	55.40	78.23	66.23	-0.09
55.79	5.21	0.05	37.68	38.74	43.01	42.82	52.29	55.33	76.92	66.50	-0.09
57.68	5.22	0.04	37.29	38.62	42.73	42.82	52.32	55.69	77.52	66.09	-0.09
59.58	5.22	0.05	37.10	38.14	42.51	42.66	52.39	56.29	76.79	66.29	-0.09
61.47	5.22	0.05	37.34	38.13	42.24	42.41	52.35	56.74	76.42	65.70	-0.09
63.37	5.21	0.05	38.17	38.36	42.12	42.14	52.24	57.04	76.37	65.54	-0.09
65.26	5.22	0.05	38.93	38.85	42.02	41.92	51.75	56.96	77.08	65.07	-0.09
67.16	5.21	0.05	39.52	39.23	41.83	41.75	50.99	56.54	76.89	64.48	-0.09
70.00	5.24	0.04	40.36	39.80	41.38	41.26	50.81	56.24	76.15	64.21	-0.09
70.95	5.24	0.05	40.67	40.04	41.26	41.18	50.70	56.27	75.33	64.14	-0.09
72.84	5.23	0.04	40.90	40.45	41.06	41.14	50.66	56.46	74.83	64.16	-0.09
74.74	5.24	0.04	40.75	40.23	40.86	40.94	50.64	56.22	75.24	63.63	-0.09
76.63	5.26	0.04	40.29	39.72	40.76	40.78	50.76	56.14	75.16	63.41	-0.09
78.53	5.23	0.04	39.50	39.13	40.48	40.56	50.83	55.76	75.46	63.59	-0.09
80.42	5.22	0.04	38.93	38.78	40.32	40.45	50.94	55.27	75.28	63.71	-0.09
82.32	5.25	0.05	38.66	38.82	40.20	40.25	50.78	54.88	74.08	63.38	-0.08
84.21	5.25	0.05	38.62	38.89	40.03	40.09	51.05	55.07	74.38	63.27	-0.07
86.11	5.26	0.05	38.83	39.07	39.97	39.89	50.76	55.61	75.66	62.42	-0.06
88.00	5.24	0.04	38.60	38.69	39.81	39.73	50.25	55.64	81.59	62.31	-0.07

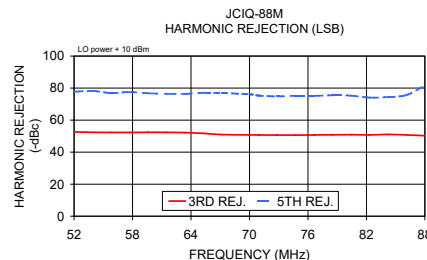
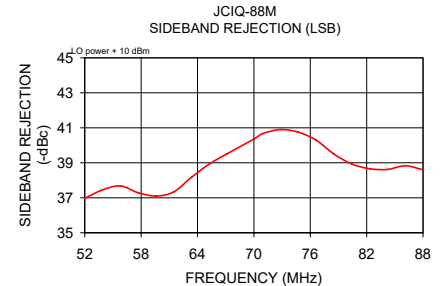
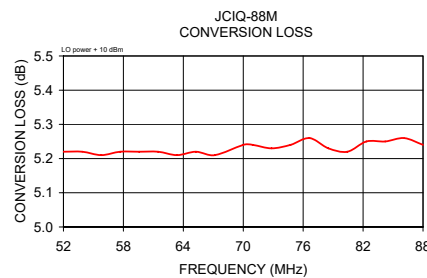

### I&Q modulation block diagram

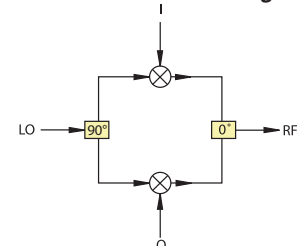

REV. C  
M151107  
JCIQ-88M  
DJ/VV/CP/AM  
200427

## Typical Performance Data

CARRIER FREQ.	CONVERSION LOSS	SIDE BAND REJECTION		CARRIER REJECTION		3rd HARMONIC SUPPRESSION		5th HARMONIC SUPPRESSION		DC OFFSET
		LSB	USB	LSB	USB	LSB	USB	LSB	USB	
(MHz)	(dB)	(-dBc)	(-dBc)	(-dBc)	(-dBc)	(-dBc)	(-dBc)	(-dBc)	(-dBc)	(mV)
52.00	5.22	36.97	37.65	43.38	43.31	52.68	55.74	77.71	66.44	-0.09
53.89	5.22	37.45	38.38	43.18	43.06	52.39	55.40	78.23	66.23	-0.09
55.79	5.21	37.68	38.74	43.01	42.82	52.29	55.33	76.92	66.50	-0.09
57.68	5.22	37.29	38.62	42.73	42.82	52.32	55.69	77.52	66.09	-0.09
59.58	5.22	37.10	38.14	42.51	42.66	52.39	56.29	76.79	66.29	-0.09
61.47	5.22	37.34	38.13	42.24	42.41	52.35	56.74	76.42	65.70	-0.09
63.37	5.21	38.17	38.36	42.12	42.14	52.24	57.04	76.37	65.54	-0.09
65.26	5.22	38.93	38.85	42.02	41.92	51.75	56.96	77.08	65.07	-0.09
67.16	5.21	39.52	39.23	41.83	41.75	50.99	56.54	76.89	64.48	-0.09
70.00	5.24	40.36	39.80	41.38	41.26	50.81	56.24	76.15	64.21	-0.09
70.95	5.24	40.67	40.04	41.26	41.18	50.70	56.27	75.33	64.14	-0.09
72.84	5.23	40.90	40.45	41.06	41.14	50.66	56.46	74.83	64.16	-0.09
74.74	5.24	40.75	40.23	40.86	40.94	50.64	56.22	75.24	63.63	-0.09
76.63	5.26	40.29	39.72	40.76	40.78	50.76	56.14	75.16	63.41	-0.09
78.53	5.23	39.50	39.13	40.48	40.56	50.83	55.76	75.46	63.59	-0.09
80.42	5.22	38.93	38.78	40.32	40.45	50.94	55.27	75.28	63.71	-0.09
82.32	5.25	38.66	38.82	40.20	40.25	50.78	54.88	74.08	63.38	-0.08
84.21	5.25	38.62	38.89	40.03	40.09	51.05	55.07	74.38	63.27	-0.07
86.11	5.26	38.83	39.07	39.97	39.89	50.76	55.61	75.66	62.42	-0.06
88.00	5.24	38.60	38.69	39.81	39.73	50.25	55.64	81.59	62.31	-0.07

LO Power=+10 dBm, I/Q Power=-5 dBm.

## Typical Performance Curves

**Conversion Loss**

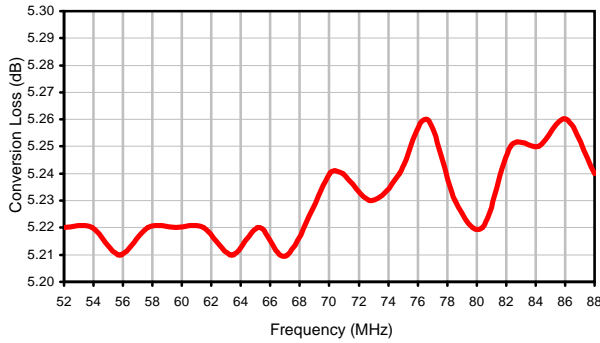

LO Power=+10 dBm, I/Q Power=-5 dBm.

**DC Offset**

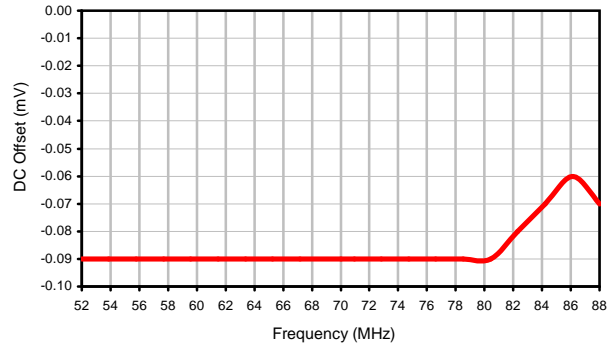

LO Power=+10 dBm, I/Q Power=-5 dBm.

**Sideband Rejection**

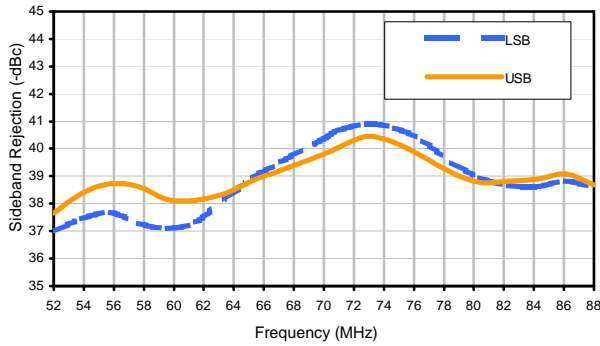

LO Power=+10 dBm, I/Q Power=-5 dBm.

**Carrier Rejection**

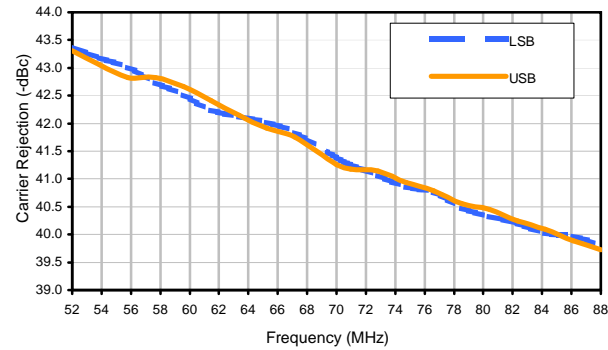

LO Power=+10 dBm, I/Q Power=-5 dBm.

**3rd Harmonic Suppression**

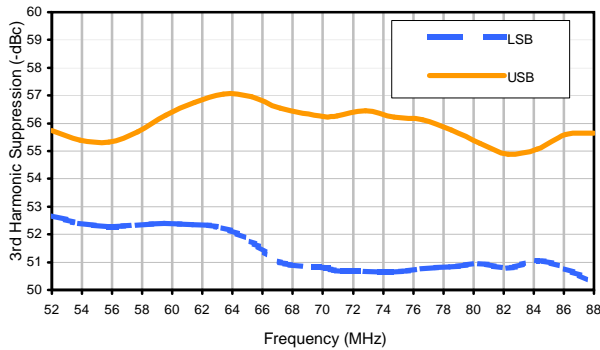

LO Power=+10 dBm, I/Q Power=-5 dBm.

**5th Harmonic Suppression**

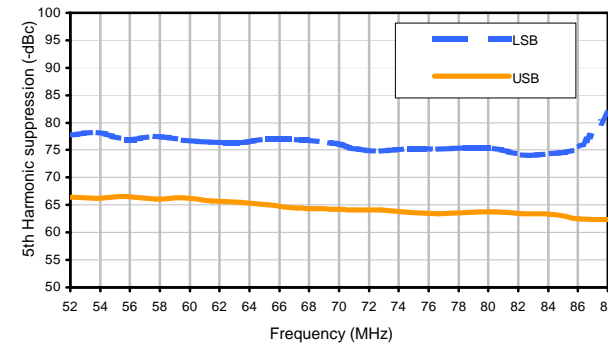

LO Power=+10 dBm, I/Q Power=-5 dBm.

## Outline Dimensions

BG291

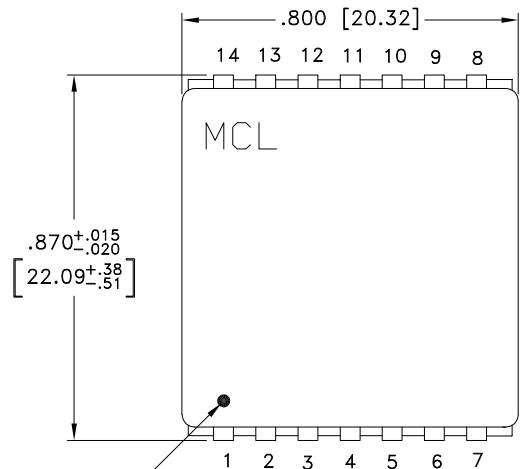

TOP VIEW

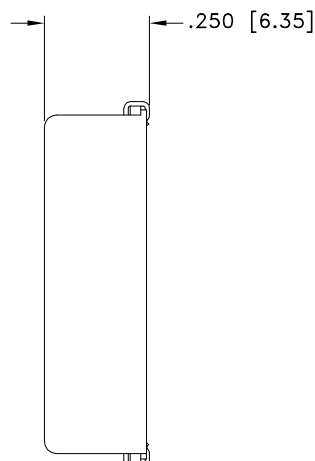

SIDE VIEW

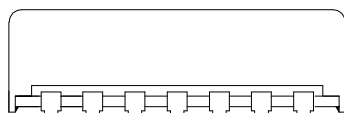

SIDE VIEW

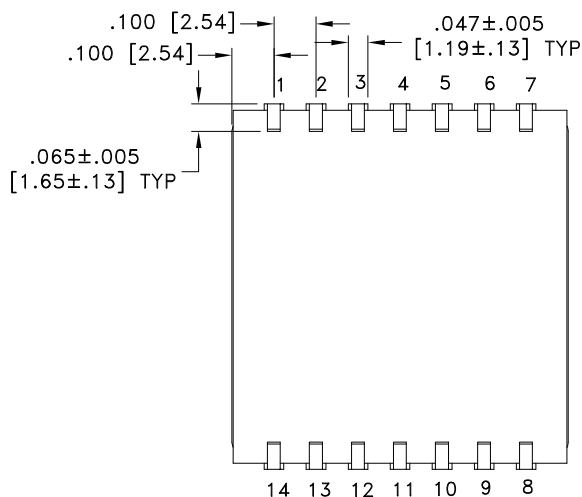

BOTTOM VIEW

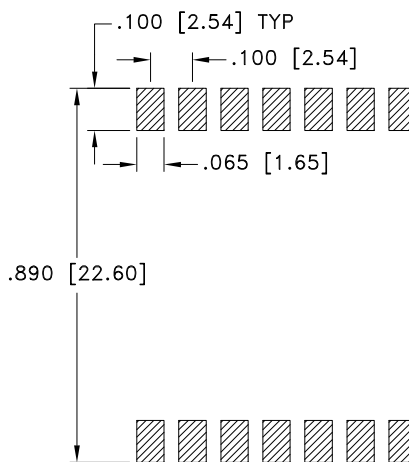

SUGGESTED LAYOUT FOR PCB LAND PATTERN (TOL ± 0.002)

 DENOTES METALLIZATION

Weight: 4 gram

Dimensions are in inches[mm]. Tolerances: 2PL±0.03[0.76]; 3 PL± 0.015 [0.381] inches[mm], unless otherwise specified

Notes:

1. Case material: Copper-Nickel alloy.
2. Base material: Printed wiring laminate.
3. Termination finish:

For RoHS Case Styles: Tin plate over Nickel plate. All models, (+) suffix.  
 For RoHS-5 Case Styles: Tin-Lead plate. All models, no (+) suffix.



P.O. Box 350166, Brooklyn, New York 11235-0003 (718) 934-4500 Fax (718) 332-4661 For detailed performance specs & shopping online see Mini-Circuits web site



The Design Engineers Search Engine Provides ACTUAL Data Instantly From MINI-CIRCUITS At: [www.minicircuits.com](http://www.minicircuits.com)

RF/IF MICROWAVE COMPONENTS

# Tape & Reel Packaging TR-F21

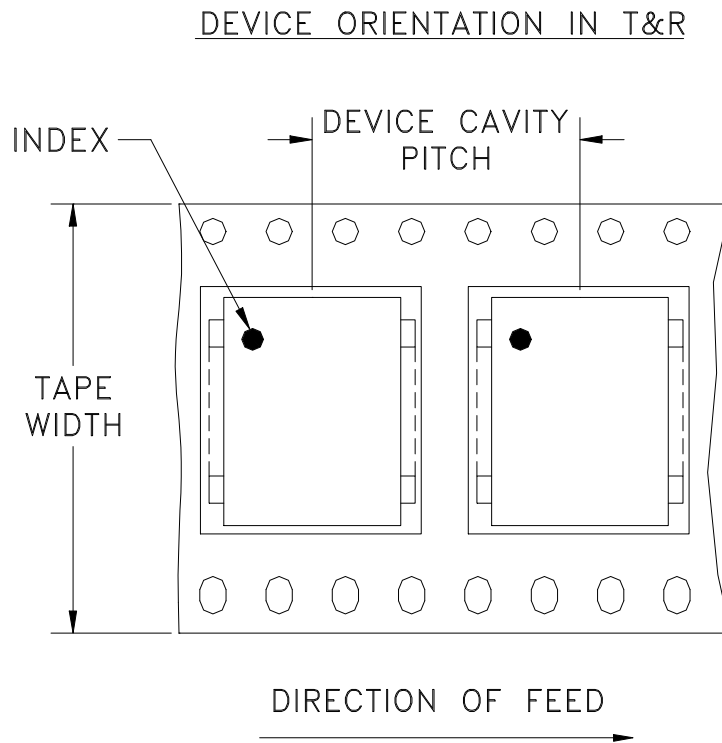

<b>Tape Width, mm</b>	<b>Device Cavity Pitch, mm</b>	<b>Reel Size, inches</b>	<b>Devices per Reel</b>
32	32	13	200

Mini-Circuits carrier tape materials provide protection from ESD (Electro-Static Discharge) during handling and transportation. Tapes are static dissipative and comply with industry standards EIA-481/EIA-541.

Go to: [www.minicircuits.com/pages/pdfs/tape.pdf](http://www.minicircuits.com/pages/pdfs/tape.pdf)



INTERNET <http://www.minicircuits.com>

P.O. Box 350166, Brooklyn, New York 11235-0003 (718) 934-4500 Fax (718) 332-4661

Distribution Centers NORTH AMERICA 800-654-7949 • 417-335-5935 • Fax 417-335-5945 • EUROPE 44-1252-832600 • Fax 44-1252-837010

Mini-Circuits ISO 9001 & ISO 14001 Certified

THIRD ANGLE PROJECTION

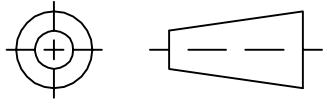

REVISIONS

REV	ECN No.	DESCRIPTION	DATE	DR	AUTH
OR	M100733	NEW RELEASE	09/19/05	MMG	WL
A	M102713	ADDED "...WITH SMOBC"	01/12/06	GT	IL

**SUGGESTED MOUNTING CONFIGURATION  
FOR BG291 CASE STYLE, "kj" & "hs" PIN CONNECTION**

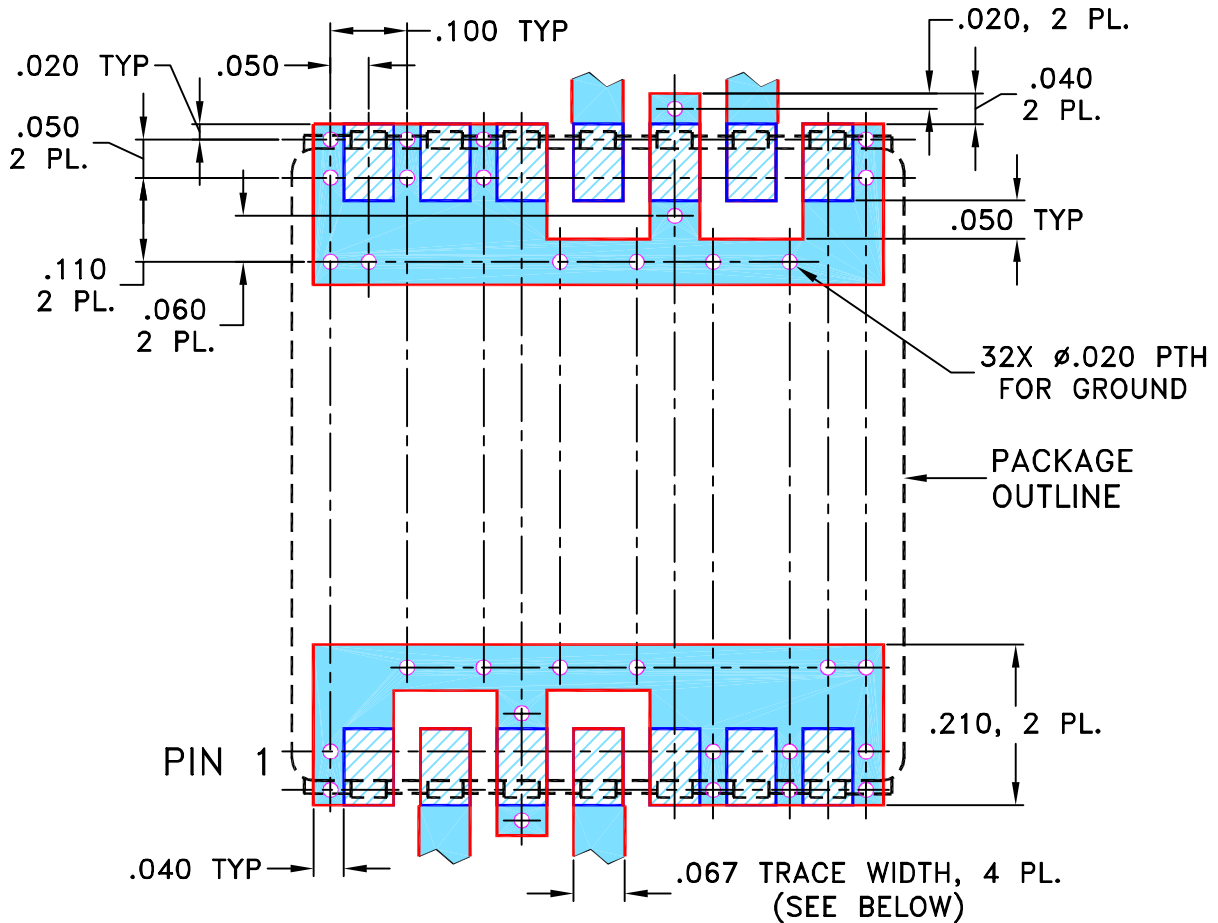

**NOTE:**

- TRACE WIDTH IS SHOWN FOR ROGERS R04350B WITH DIELECTRIC THICKNESS .030" ± .002"; COPPER: 1/2 OZ. EACH SIDE. FOR OTHER MATERIALS TRACE WIDTH MAY NEED TO BE MODIFIED.
- BOTTOM SIDE OF THE PCB IS CONTINUOUS GROUND PLANE.



DENOTES PCB COPPER LAYOUT WITH SMOBC (SOLDER MASK OVER BARE COPPER)

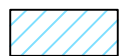

DENOTES COPPER LAND PATTERN FREE OF SOLDER MASK

UNLESS OTHERWISE SPECIFIED	INITIALS	DATE
DIMENSIONS ARE IN INCHES	DRAWN MMG	09/09/05
TOLERANCES ON:	CHECKED AV	09/16/05
2 PL DECIMALS ±	APPROVED WL	09/19/05
3 PL DECIMALS ± .005		
ANGLES ±		
FRACTIONS ±		



**Mini-Circuits®** 13 Neptune Avenue  
Brooklyn NY 11235

PL, kj/hs, BG291, JCIR-4MH/JCIQ, TB-21

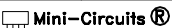
SIZE A	CODE IDENT 15542	DRAWING NO: 98-PL-209	REV: A
FILE: 98PL209	SCALE: 4:1	SHEET: 1 OF 1	

 THIS DOCUMENT AND ITS CONTENTS ARE THE PROPERTY OF MINI-CIRCUITS. EXCEPT FOR USE EXPRESSLY GRANTED, IN WRITING, TO ITS VENDORS, VENDEE AND THE UNITED STATES GOVERNMENT, MINI-CIRCUITS RESERVES ALL PROPRIETARY DESIGN, USE, MANUFACTURING AND REPRODUCTION RIGHTS THERETO. THESE CONTENTS SHALL NOT BE USED, DUPLICATED OR DISCLOSED TO ANY OUTSIDE PARTY, IN WHOLE OR IN PART, WITHOUT WRITTEN PERMISSION OF MINI-CIRCUITS.

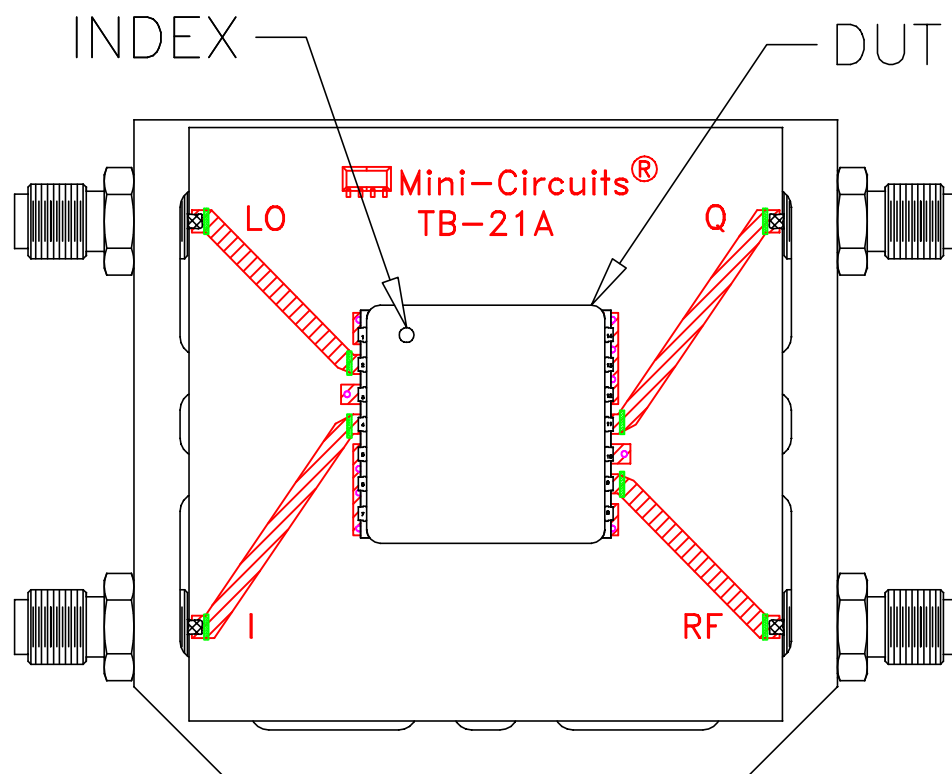
# Evaluation Board and Circuit



TB-21

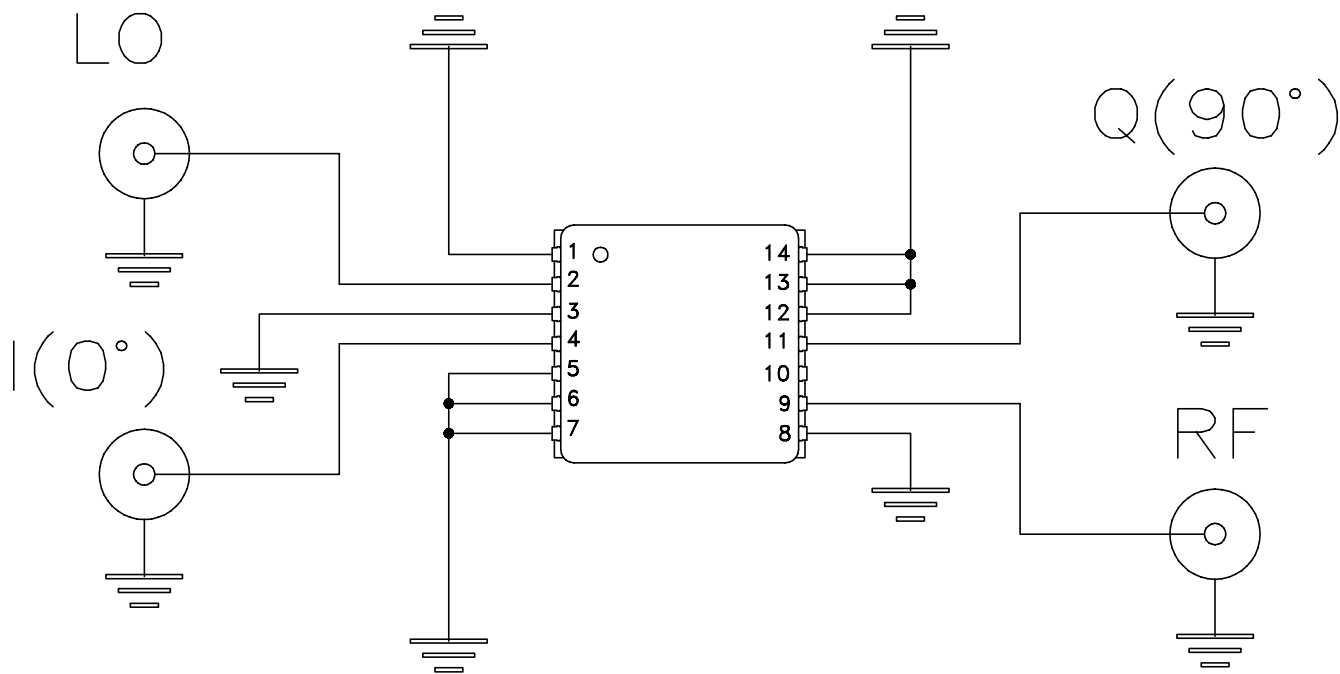

Schematic Diagram

**Notes:**

1. 50 Ohm SMA Female connectors.
2. PCB Material: R04350 or equivalent.  
Dielectric Constant=3.5, Thickness=.030 inch.

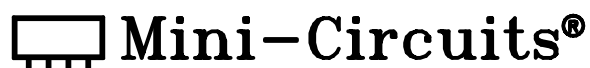

All Mini-Circuits products are manufactured under exacting quality assurance and control standards, and are capable of meeting published specifications after being subjected to any or all of the following physical and environmental test.

Specification	Test/Inspection Condition	Reference/Spec
Operating Temperature	-55° to 100°C Ambient Environment	Individual Model Data Sheet
Storage Temperature	-55° to 100° C Ambient Environment	Individual Model Data Sheet
Humidity	90 to 95% RH, 240 hours, 50°C	MIL-STD-202, Method 103, Condition A, Except 50°C and end-point electrical test done within 12 hours
Thermal Shock	-55° to 100°C, 100 cycles	MIL-STD-202, Method 107, Condition A-3, except +100°C
Solder Reflow Heat	Sn-Pb Eutetic Process: 225°C peak Pb-Free Process 245° - 250°C peak	J-STD-020, Table 4-1, 4-2 and 5-2, Figure 5-1
Solderability	10X Magnification	J-STD-002, 95% Coverage
Vibration (High Frequency)	20g peak, 10-2000 Hz, 12 times in each of three perpendicular directions (total 36)	MIL-STD-202, Method 204, Condition D
Mechanical Shock	50g, 11 ms, 1/2-sine, 18 shocks: 3 each direction, each of 3 axes	MIL-STD-202, Method 213, Condition A
Marking Resistance to Solvents	Isopropyl alcohol + mineral spirits at 25°C; terpene defluxer at 25°C; distilled water + proylene glycol monomethyl ether + monoethanolamine at 63°C to 70°C	MIL-STD-202, Method 215