

Surface Mount I&Q Demodulator

50Ω 104 to 176 MHz

JCIQ-176D+ JCIQ-176D



Generic photo used for illustration purposes only

CASE STYLE: BG291

+RoHS Compliant

The +Suffix identifies RoHS Compliance. See our web site for RoHS Compliance methodologies and qualifications

Maximum Ratings

Operating Temperature	-55°C to 100°C
Storage Temperature	-55°C to 100°C
LO/RF Power	50mW
I&Q Current	40mA

Permanent damage may occur if any of these limits are exceeded.

Pin Connections

LO (carrier)	2
RF (signal)	9
I (0°)(ref.)	4
Q (90°)*	11
GROUND	1,3,5,6,7,8,10,12,13,14

*Q=+90° for LO<RF
Q=-90° for LO>RF

Outline Drawing

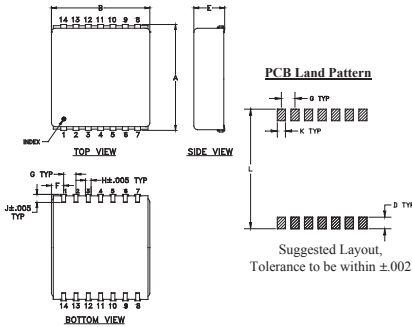

Outline Dimensions (inch/mm)

A	B	C	D	E	F	G	
.870	.800	--	.100	.250	.100	.100	
22.10	20.32	--	2.54	6.35	2.54	2.54	
H	J	K	L				wt
.047	.065	.065	.890				grams
1.19	1.65	1.65	22.61				4.0

Demo Board MCL P/N: TB-21 Suggested PCB Layout (PL-209)

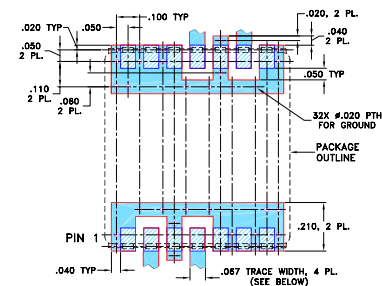

- NOTE:
- TRACE WIDTH IS SHOWN FOR ROGERS RO4350B WITH DIELECTRIC THICKNESS .030" ± .002"; COPPER: 1/2 OZ. EACH SIDE. FOR OTHER MATERIALS TRACE WIDTH MAY NEED TO BE MODIFIED.
 - BOTTOM SIDE OF THE PCB IS CONTINUOUS GROUND PLANE.
- DENOTES PCB COPPER LAYOUT WITH SMOBC (SOLDER MASK OVER BARE COPPER)
- DENOTES COPPER LAND PATTERN FREE OF SOLDER MASK

Features

- shielded metal case with J-leads
- excellent 3rd & 5th order harmonic suppression
- good amplitude & phase unbalance
- aqueous washable

Applications

- communication systems

Demodulator Electrical Specifications

MODEL NO.	FREQUENCY (MHz)		CONVERSION LOSS (dB)			AMPLITUDE UNBALANCE (dB)		PHASE UNBALANCE (Deg.)		HARMONIC SUPPRESSION (dBc)					
	RF (SIGNAL) f _r	LO (CARRIER) f _l	I&Q Min.	I&Q Max.	\bar{x}	σ	Max.	Typ.	Max.	with reference to 90°		3X1/Q		5X1/Q	
										Typ.	Max.	Typ.	Min.	Typ.	Min.
JCIQ-176D	104	176	DC	5	5.5	0.1	7.0	0.15	0.6	2	5	52	40	65	50

- Notes:
1. Operating LO Power: 10±0.5 dBm
 2. 1 dB Compression at +4 dBm RF input
 3. DC offset 1mV typ.
 4. Conversion Loss=RF power, dBm - (I+Q) power, dBm

Typical Performance Data

Frequency (MHz)	Conversion Loss (dB)		Amplitude Unbalance (dB)	Phase (I&Q) (deg.)	Frequency (MHz)		DC Offset (mV)
	LO=140MHz RF	I&Q			LO	RF	
140.30	0.30	5.67	0.07	90.71	96.00	96.10	0.18
140.54	0.54	5.61	0.08	90.55	100.00	100.10	0.19
140.77	0.77	5.56	0.07	90.69	104.00	104.10	0.19
141.01	1.01	5.55	0.09	90.71	107.79	107.89	0.19
141.24	1.24	5.57	0.08	90.68	115.37	115.47	0.19
141.48	1.48	5.55	0.09	90.75	119.16	119.26	0.19
141.71	1.71	5.55	0.10	90.72	122.95	123.05	0.19
141.95	1.95	5.54	0.11	90.95	126.74	126.84	0.20
142.18	2.18	5.55	0.10	91.00	134.32	134.42	0.19
142.42	2.42	5.54	0.12	90.99	138.11	138.21	0.19
142.78	2.78	5.55	0.10	91.18	141.90	142.00	0.19
143.03	3.03	5.55	0.07	91.27	145.68	145.78	0.21
143.27	3.27	5.55	0.04	91.29	153.26	153.36	0.24
143.52	3.52	5.56	0.04	91.11	157.05	157.15	0.25
143.77	3.77	5.56	0.03	91.16	160.84	160.94	0.25
144.01	4.01	5.55	0.03	90.87	164.63	164.73	0.26
144.26	4.26	5.56	0.03	90.83	172.21	172.31	0.25
144.51	4.51	5.56	0.05	90.78	176.00	176.10	0.26
144.75	4.75	5.55	0.10	90.81	180.00	180.10	0.25
145.00	5.00	5.56	0.12	91.09	184.00	184.10	0.26

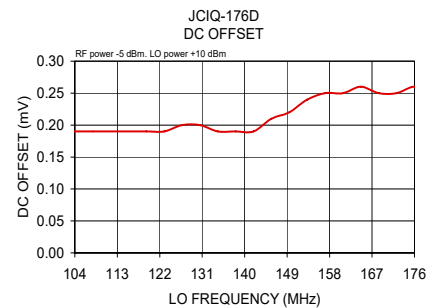
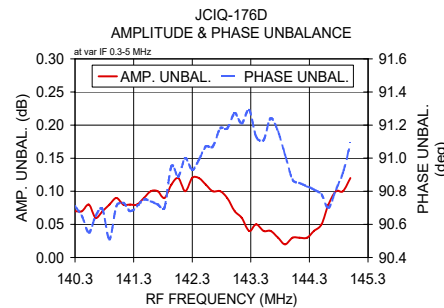

I&Q demodulation block diagram

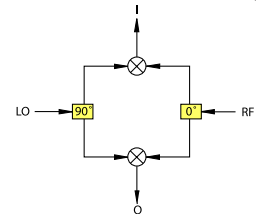

Notes

- Performance and quality attributes and conditions not expressly stated in this specification document are intended to be excluded and do not form a part of this specification document.
- Electrical specifications and performance data contained in this specification document are based on Mini-Circuit's applicable established test performance criteria and measurement instructions.
- The parts covered by this specification document are subject to Mini-Circuit's standard limited warranty and terms and conditions (collectively, "Standard Terms"); Purchasers of this part are entitled to the rights and benefits contained therein. For a full statement of the Standard Terms and the exclusive rights and remedies thereunder, please visit Mini-Circuit's website at www.minicircuits.com/MCLStore/terms.jsp



www.minicircuits.com P.O. Box 350166, Brooklyn, NY 11235-0003 (718) 934-4500 sales@minicircuits.com

REV. C
M151107
JCIQ-176D
DJ/VV/CP/AM
200427
Page 1 of 1

I&Q Demodulator

JCIQ-176D

Typical Performance Data

FREQUENCY LO=140MHz (MHz)		CONVERSION LOSS (dB)	AMPLITUDE UNBALANCE (dB)		PHASE UNBALANCE (deg.)		FREQUENCY (MHz)		DC OFFSET (mV)
RF	I/Q		I/Q	I/Q	LO	RF			
140.30	0.30	5.67	0.07	90.71	96.00	96.10	0.18		
140.54	0.54	5.61	0.08	90.55	100.00	100.10	0.19		
140.77	0.77	5.56	0.07	90.69	104.00	104.10	0.19		
141.01	1.01	5.55	0.09	90.71	107.79	107.89	0.19		
141.24	1.24	5.57	0.08	90.68	115.37	115.47	0.19		
141.48	1.48	5.55	0.09	90.75	119.16	119.26	0.19		
141.71	1.71	5.55	0.10	90.72	122.95	123.05	0.19		
141.95	1.95	5.54	0.11	90.95	126.74	126.84	0.20		
142.18	2.18	5.55	0.10	91.00	134.32	134.42	0.19		
142.42	2.42	5.54	0.12	90.99	138.11	138.21	0.19		
142.78	2.78	5.55	0.10	91.18	141.90	142.00	0.19		
143.03	3.03	5.55	0.07	91.27	145.68	145.78	0.21		
143.27	3.27	5.55	0.04	91.29	153.26	153.36	0.24		
143.52	3.52	5.56	0.04	91.11	157.05	157.15	0.25		
143.77	3.77	5.56	0.03	91.16	160.84	160.94	0.25		
144.01	4.01	5.55	0.03	90.87	164.63	164.73	0.26		
144.26	4.26	5.56	0.03	90.83	172.21	172.31	0.25		
144.51	4.51	5.56	0.05	90.78	176.00	176.10	0.26		
144.75	4.75	5.55	0.10	90.81	180.00	180.10	0.25		
145.00	5.00	5.56	0.12	91.09	184.00	184.10	0.26		

RF Power=-5 dBm, LO Power=+10 dBm

Conversion Loss (dB) = RF Input Power (dBm) - I/Q Output Power (dBm)

Typical Performance Curves

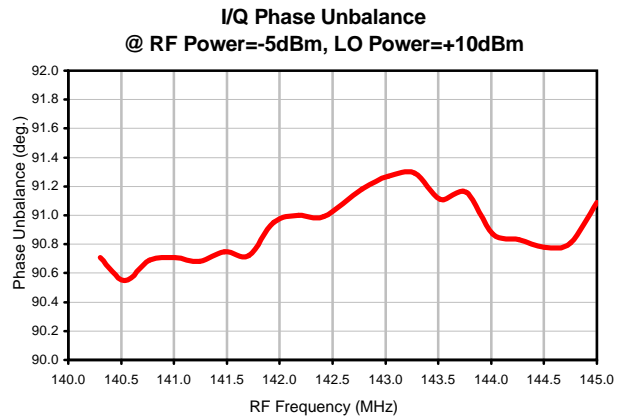
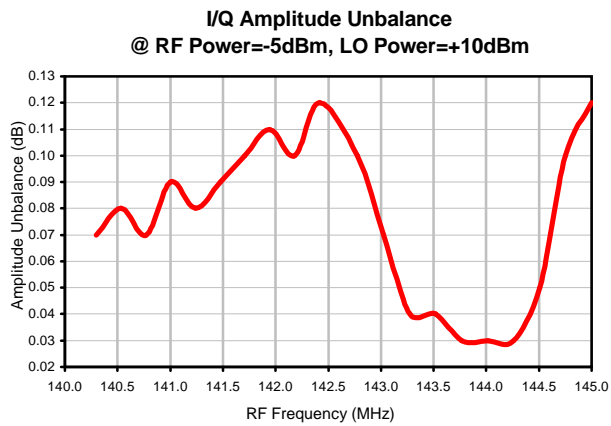
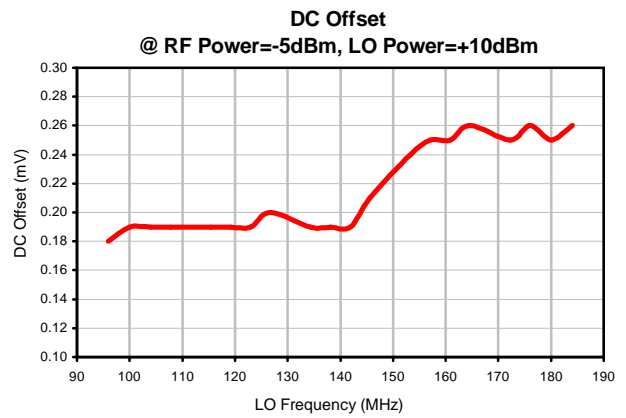
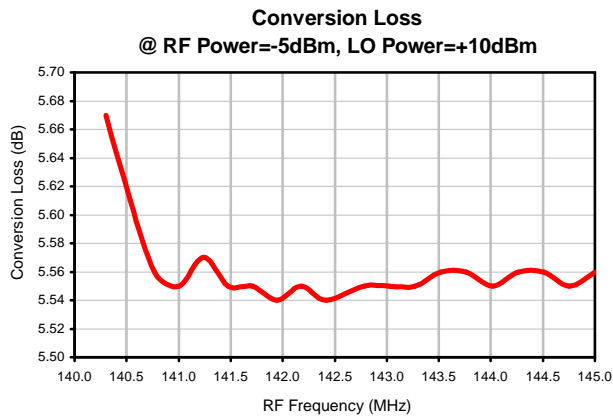

Outline Dimensions

BG291

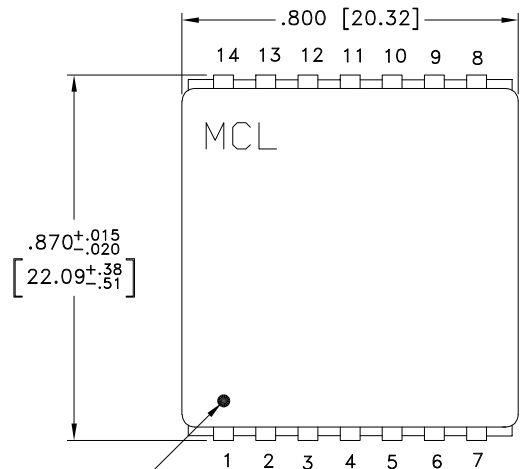

TOP VIEW

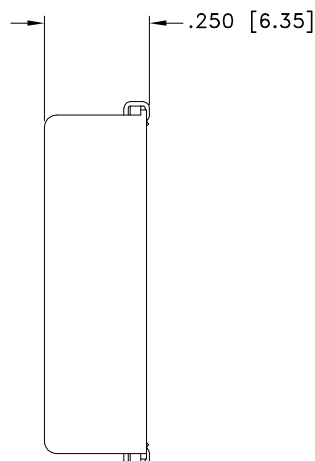

SIDE VIEW

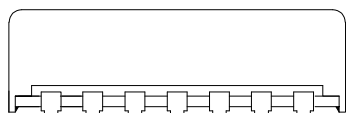

SIDE VIEW

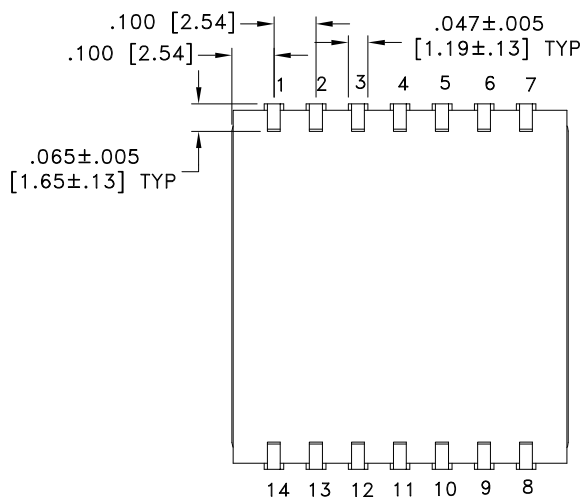

BOTTOM VIEW

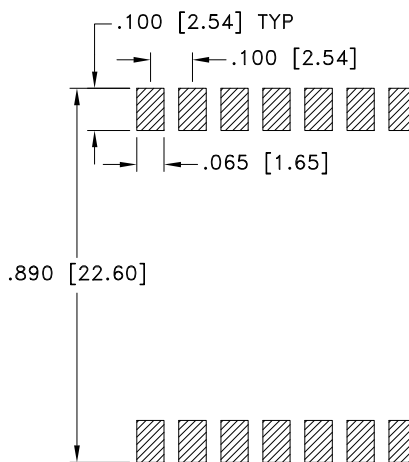

SUGGESTED LAYOUT FOR PCB LAND PATTERN (TOL ±.002)

 DENOTES METALLIZATION

Weight: 4 gram

Dimensions are in inches[mm]. Tolerances: 2PL±0.03[0.76]; 3 PL± 0.015 [0.381] inches[mm], unless otherwise specified

Notes:

1. Case material: Copper-Nickel alloy.
2. Base material: Printed wiring laminate.
3. Termination finish:

For RoHS Case Styles: Tin plate over Nickel plate. All models, (+) suffix.
 For RoHS-5 Case Styles: Tin-Lead plate. All models, no (+) suffix.



P.O. Box 350166, Brooklyn, New York 11235-0003 (718) 934-4500 Fax (718) 332-4661 For detailed performance specs & shopping online see Mini-Circuits web site



The Design Engineers Search Engine Provides ACTUAL Data Instantly From MINI-CIRCUITS At: www.minicircuits.com

RF/IF MICROWAVE COMPONENTS

Tape & Reel Packaging TR-F21

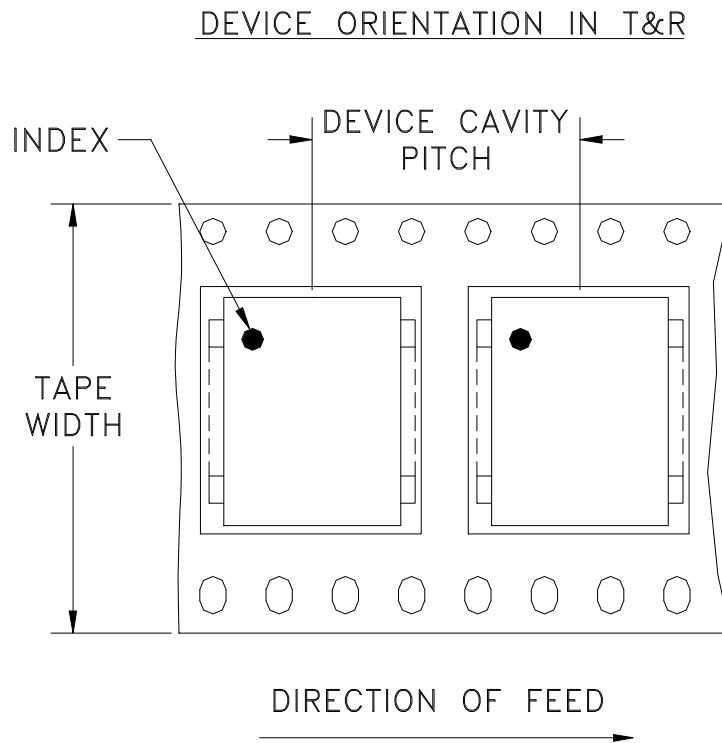

Tape Width, mm	Device Cavity Pitch, mm	Reel Size, inches	Devices per Reel
32	32	13	200

Mini-Circuits carrier tape materials provide protection from ESD (Electro-Static Discharge) during handling and transportation. Tapes are static dissipative and comply with industry standards EIA-481/EIA-541.

Go to: www.minicircuits.com/pages/pdfs/tape.pdf



INTERNET <http://www.minicircuits.com>

P.O. Box 350166, Brooklyn, New York 11235-0003 (718) 934-4500 Fax (718) 332-4661

Distribution Centers NORTH AMERICA 800-654-7949 • 417-335-5935 • Fax 417-335-5945 • EUROPE 44-1252-832600 • Fax 44-1252-837010

Mini-Circuits ISO 9001 & ISO 14001 Certified

THIRD ANGLE PROJECTION

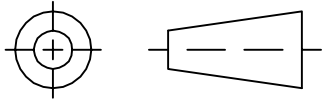

REVISIONS

REV	ECN No.	DESCRIPTION	DATE	DR	AUTH
OR	M100733	NEW RELEASE	09/19/05	MMG	WL
A	M102713	ADDED "...WITH SMOBC"	01/12/06	GT	IL

**SUGGESTED MOUNTING CONFIGURATION
FOR BG291 CASE STYLE, "kj" & "hs" PIN CONNECTION**

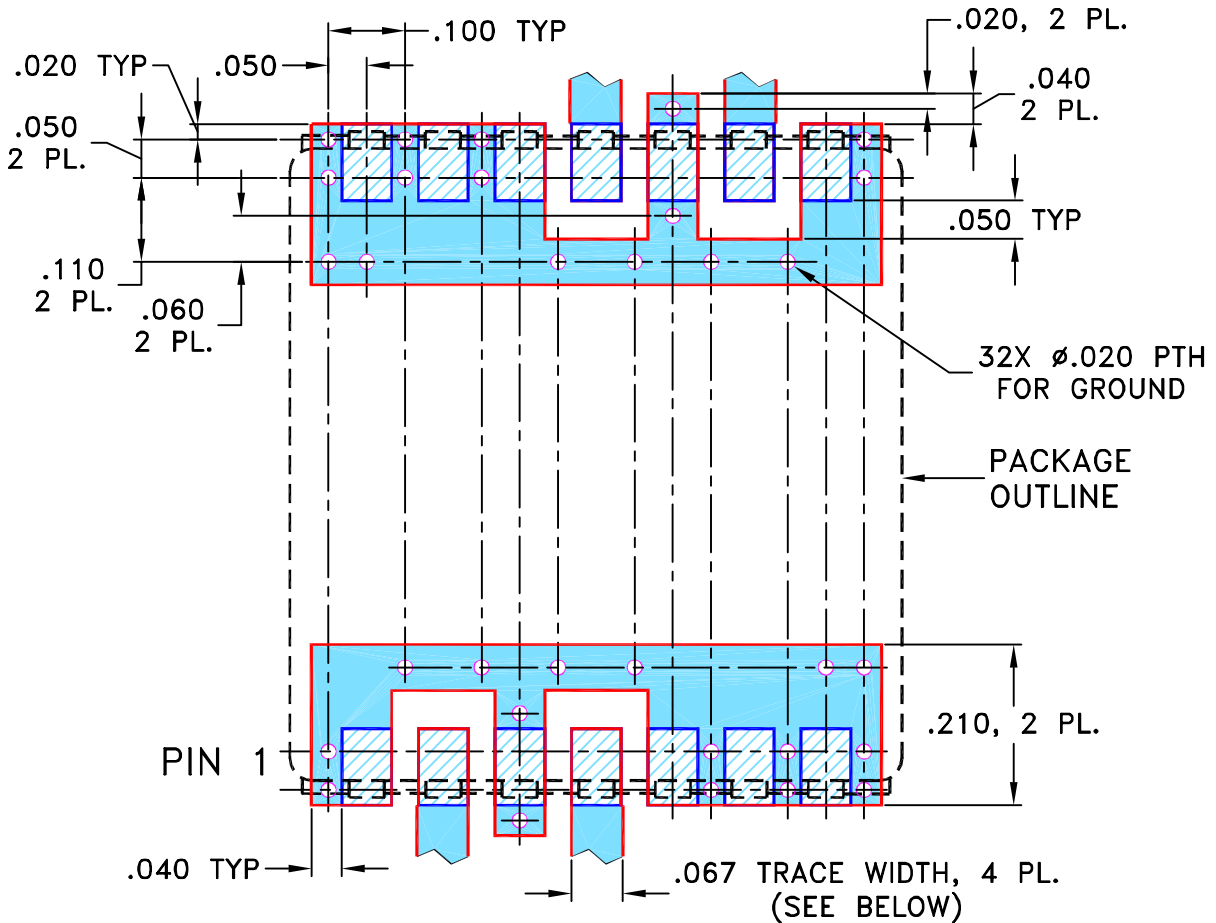

NOTE:

- TRACE WIDTH IS SHOWN FOR ROGERS R04350B WITH DIELECTRIC THICKNESS .030" ± .002"; COPPER: 1/2 OZ. EACH SIDE. FOR OTHER MATERIALS TRACE WIDTH MAY NEED TO BE MODIFIED.
- BOTTOM SIDE OF THE PCB IS CONTINUOUS GROUND PLANE.



DENOTES PCB COPPER LAYOUT WITH SMOBC (SOLDER MASK OVER BARE COPPER)

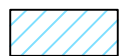

DENOTES COPPER LAND PATTERN FREE OF SOLDER MASK

UNLESS OTHERWISE SPECIFIED	INITIALS	DATE
DIMENSIONS ARE IN INCHES	DRAWN MMG	09/09/05
TOLERANCES ON:	CHECKED AV	09/16/05
2 PL DECIMALS ±	APPROVED WL	09/19/05
3 PL DECIMALS ± .005		
ANGLES ±		
FRACTIONS ±		



Mini-Circuits® 13 Neptune Avenue
Brooklyn NY 11235

PL, kj/hs, BG291, JCIR-4MH/JCIQ, TB-21

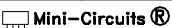
SIZE A	CODE IDENT 15542	DRAWING NO: 98-PL-209	REV: A
FILE: 98PL209	SCALE: 4:1	SHEET: 1 OF 1	

 THIS DOCUMENT AND ITS CONTENTS ARE THE PROPERTY OF MINI-CIRCUITS. EXCEPT FOR USE EXPRESSLY GRANTED, IN WRITING, TO ITS VENDORS, VENDEE AND THE UNITED STATES GOVERNMENT, MINI-CIRCUITS RESERVES ALL PROPRIETARY DESIGN, USE, MANUFACTURING AND REPRODUCTION RIGHTS THERETO. THESE CONTENTS SHALL NOT BE USED, DUPLICATED OR DISCLOSED TO ANY OUTSIDE PARTY, IN WHOLE OR IN PART, WITHOUT WRITTEN PERMISSION OF MINI-CIRCUITS.

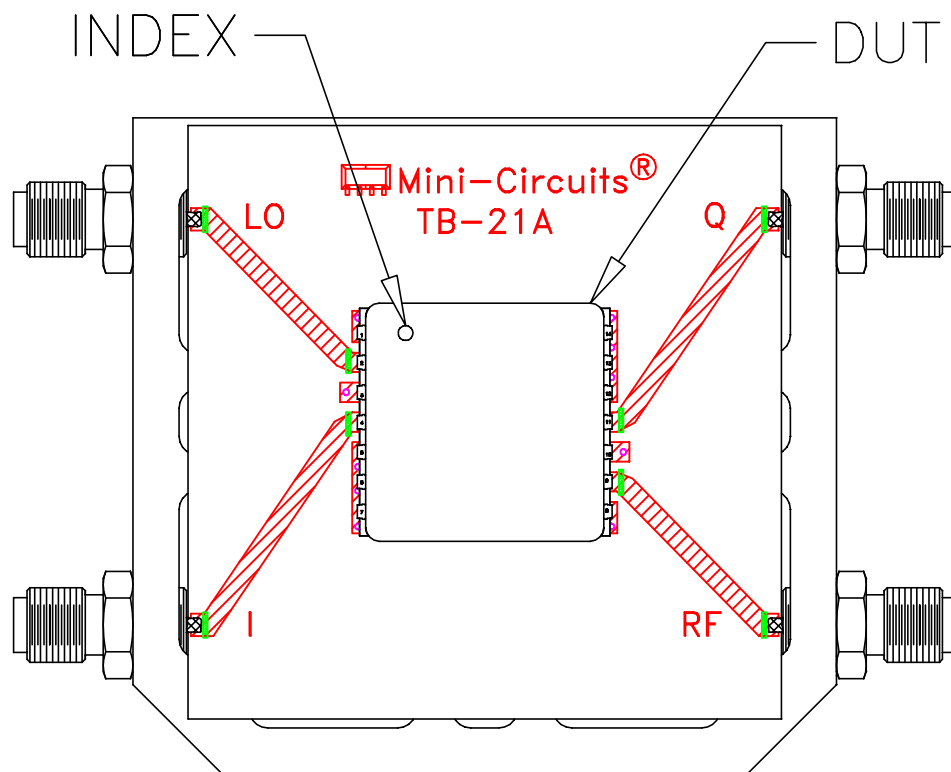
Evaluation Board and Circuit



TB-21

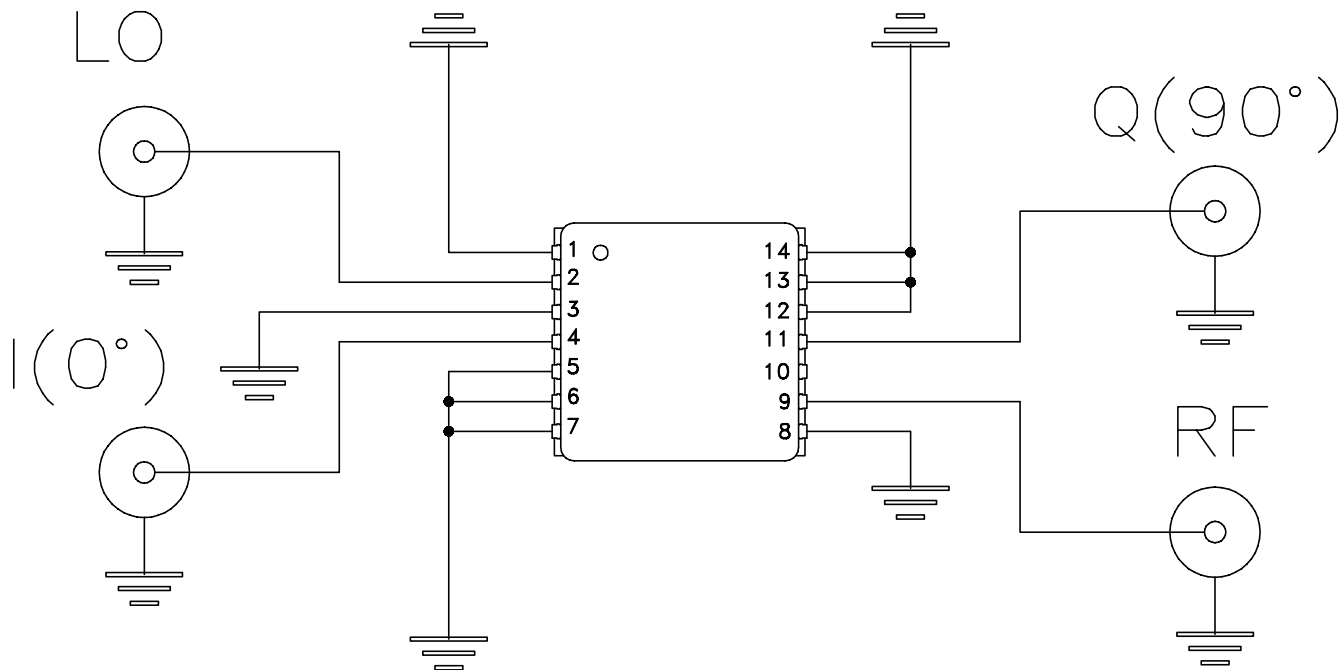

Schematic Diagram

Notes:

1. 50 Ohm SMA Female connectors.
2. PCB Material: R04350 or equivalent.
Dielectric Constant=3.5, Thickness=.030 inch.

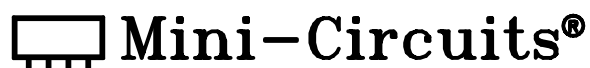

All Mini-Circuits products are manufactured under exacting quality assurance and control standards, and are capable of meeting published specifications after being subjected to any or all of the following physical and environmental test.

Specification	Test/Inspection Condition	Reference/Spec
Operating Temperature	-55° to 100°C Ambient Environment	Individual Model Data Sheet
Storage Temperature	-55° to 100° C Ambient Environment	Individual Model Data Sheet
Humidity	90 to 95% RH, 240 hours, 50°C	MIL-STD-202, Method 103, Condition A, Except 50°C and end-point electrical test done within 12 hours
Thermal Shock	-55° to 100°C, 100 cycles	MIL-STD-202, Method 107, Condition A-3, except +100°C
Solder Reflow Heat	Sn-Pb Eutetic Process: 225°C peak Pb-Free Process 245° - 250°C peak	J-STD-020, Table 4-1, 4-2 and 5-2, Figure 5-1
Solderability	10X Magnification	J-STD-002, 95% Coverage
Vibration (High Frequency)	20g peak, 10-2000 Hz, 12 times in each of three perpendicular directions (total 36)	MIL-STD-202, Method 204, Condition D
Mechanical Shock	50g, 11 ms, 1/2-sine, 18 shocks: 3 each direction, each of 3 axes	MIL-STD-202, Method 213, Condition A
Marking Resistance to Solvents	Isopropyl alcohol + mineral spirits at 25°C; terpene defluxer at 25°C; distilled water + proylene glycol monomethyl ether + monoethanolamine at 63°C to 70°C	MIL-STD-202, Method 215