

# Bandpass Filter

## JCBP-900+

50Ω 480 to 1320 MHz

### Maximum Ratings

Operating Temperature	-40°C to 85°C
Storage Temperature	-55°C to 100°C
RF Power Input	0.5W

Permanent damage may occur if any of these limits are exceeded.

### Pin Connections

INPUT	2
OUTPUT	9
GROUND	1,3,4,5,6,7,8,10,11,12,13,14

### Outline Drawing

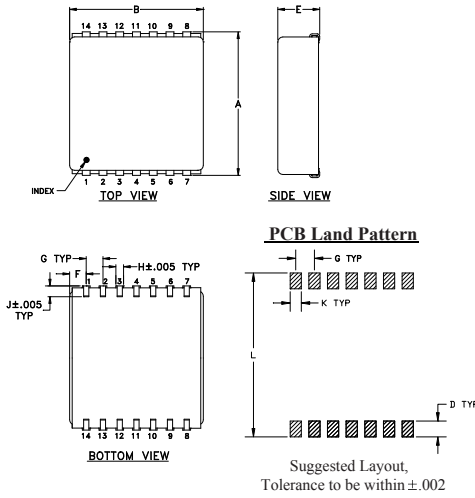

### Outline Dimensions (inch/mm)

A	B	C	D	E	F
.870	.800	--	.100	.250	.100
22.09	20.32	--	2.54	6.35	2.54
G	H	J	K	L	wt.
.100	.047	.065	.065	.890	grams
2.54	1.19	1.65	1.65	22.60	4.0

### Demo Board MCL P/N: TB-442+ Suggested PCB Layout(PL-269)

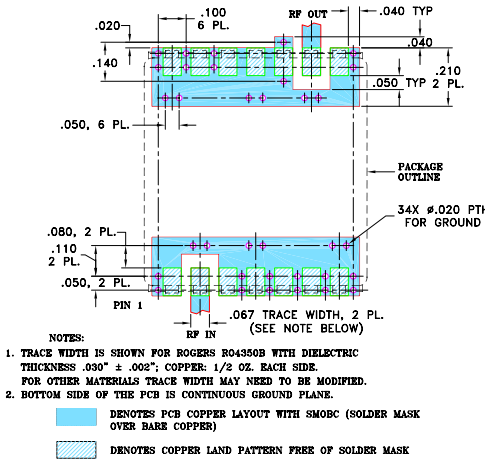

### Features

- Good VSWR, 1.2:1 typ @ passband
- High stopband rejection
- Aqueous washable

### Applications

- Harmonic rejection
- Transmitters/receivers
- Military communications



CASE STYLE: BG291

### +RoHS Compliant

The +Suffix identifies RoHS Compliance. See our web site for RoHS Compliance methodologies and qualifications

### Bandpass Filter Electrical Specifications (T<sub>AMB</sub> = 25°C)

CENTER FREQ. (MHz)	PASSBAND (MHz) (Loss < 2dB)	STOPBANDS (MHz)			VSWR (:1)	
		Loss > 20dB	Loss 35dB Typ.	F5 F6	Passband Max.	Stopband Typ.
900	F1 - F2	F3 F4	F5 F6	1800 - 3000	2.0	20

### Typical Frequency Response

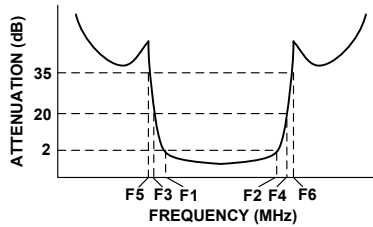

### Functional Schematic

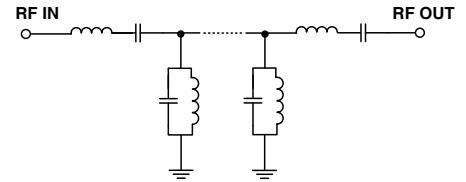

### Typical Performance Data at 25°C

Frequency (MHz)	Insertion Loss (dB)	VSWR (:1)
4.0	76.70	1737.18
100.0	52.57	434.30
200.0	62.04	248.17
376.0	37.48	69.49
380.0	35.44	66.82
420.0	15.63	26.33
438.0	7.66	9.33
450.0	3.67	3.91
480.0	0.85	1.15
900.0	0.78	1.47
1320.0	1.01	1.27
1420.0	1.98	2.25
1490.0	3.76	3.95
1550.0	7.41	6.37
1650.0	15.15	10.25
1790.0	33.08	12.26
1800.0	35.10	12.44
2500.0	34.80	13.09
3000.0	40.09	10.69

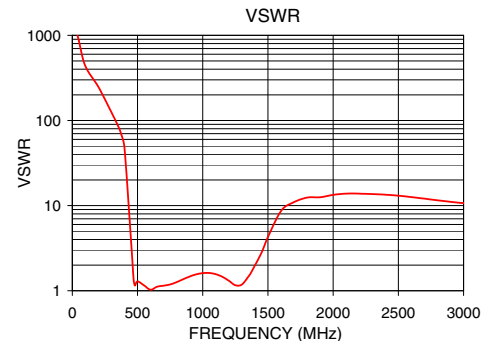

### Notes

- Performance and quality attributes and conditions not expressly stated in this specification document are intended to be excluded and do not form a part of this specification document.
- Electrical specifications and performance data contained in this specification document are based on Mini-Circuits' applicable established test performance criteria and measurement instructions.
- The parts covered by this specification document are subject to Mini-Circuits standard limited warranty and terms and conditions (collectively, "Standard Terms"); Purchasers of this part are entitled to the rights and benefits contained therein. For a full statement of the Standard Terms and the exclusive rights and remedies thereunder, please visit Mini-Circuits' website at [www.minicircuits.com/MCLStore/terms.jsp](http://www.minicircuits.com/MCLStore/terms.jsp)



# Surface Mount Band Pass Filter

# JCBP-900+

## Typical Performance Data

FREQ. (MHz)	INSERTION LOSS (dB)			INPUT RETURN LOSS (dB)			OUTPUT RETURNLOSS (dB)		
	@ -40° C	@ +25° C	@ +85° C	@ -40° C	@ +25° C	@ +85° C	@ -40° C	@ +25° C	@ +85° C
0.5	97.75	91.25	105.36	0.01	0.00	0.00	0.01	0.00	0.00
10	69.15	69.30	69.26	0.01	0.00	0.01	0.01	0.01	0.01
20	63.18	63.48	62.94	0.01	0.01	0.01	0.00	0.01	0.00
30	59.33	59.50	59.25	0.01	0.01	0.01	0.01	0.03	0.02
40	57.38	57.24	57.21	0.01	0.01	0.01	0.01	0.02	0.02
50	55.73	55.63	55.72	0.01	0.01	0.01	0.00	0.02	0.03
60	54.36	54.28	54.48	0.01	0.01	0.02	0.00	0.03	0.05
70	53.53	53.56	53.62	0.01	0.01	0.02	0.00	0.03	0.06
80	53.10	52.88	53.11	0.00	0.01	0.01	0.00	0.04	0.07
90	52.55	52.48	52.54	0.00	0.02	0.02	0.01	0.05	0.08
100	52.25	52.46	52.35	0.02	0.02	0.03	0.01	0.06	0.10
150	55.66	55.62	55.63	0.02	0.03	0.05	0.07	0.13	0.17
210	56.36	56.87	56.78	0.04	0.06	0.07	0.17	0.25	0.31
250	47.77	47.86	47.83	0.07	0.09	0.11	0.26	0.33	0.40
300	45.55	45.63	45.84	0.10	0.13	0.16	0.37	0.46	0.54
350	46.61	46.61	46.62	0.18	0.21	0.25	0.46	0.57	0.66
376	37.32	37.12	36.85	0.23	0.28	0.31	0.48	0.60	0.70
380	35.36	35.12	34.87	0.25	0.30	0.34	0.48	0.61	0.71
390	30.29	30.06	29.81	0.28	0.33	0.40	0.50	0.65	0.75
400	25.28	25.02	24.77	0.34	0.40	0.46	0.54	0.69	0.80
420	15.75	15.53	15.31	0.64	0.73	0.83	0.75	0.95	1.09
430	11.16	10.98	10.79	1.04	1.19	1.32	1.11	1.37	1.56
440	6.97	6.87	6.75	1.99	2.24	2.44	2.02	2.37	2.63
450	3.78	3.78	3.76	4.15	4.54	4.86	4.09	4.57	4.95
460	1.82	1.92	1.99	8.33	8.86	9.30	8.07	8.68	9.13
470	0.96	1.10	1.20	15.24	15.92	16.48	14.35	14.93	15.42
480	0.67	0.82	0.92	28.19	28.89	29.54	22.76	22.77	22.95
500	0.59	0.72	0.81	22.36	22.42	22.59	21.59	21.83	22.17
600	0.42	0.53	0.62	22.95	23.11	23.38	23.90	24.28	24.68
700	0.38	0.51	0.60	17.88	17.73	17.75	18.57	18.71	18.98
800	0.43	0.57	0.68	16.46	15.96	15.70	17.13	16.88	16.80
900	0.58	0.73	0.86	13.47	13.13	12.95	13.88	13.74	13.72
1000	0.64	0.80	0.92	11.93	11.72	11.59	12.23	12.23	12.22
1100	0.65	0.81	0.94	12.63	12.44	12.37	12.82	12.95	13.04
1200	0.54	0.73	0.87	16.59	16.19	16.04	17.33	17.59	17.91
1300	0.53	0.75	0.92	17.40	16.22	15.63	18.83	17.78	17.30
1320	0.67	0.91	1.10	15.57	14.64	14.11	16.52	15.70	15.24
1400	1.24	1.55	1.79	9.45	9.17	8.98	9.19	8.98	8.79
1500	3.94	4.30	4.64	4.33	4.48	4.54	3.59	3.67	3.68
1600	10.67	11.25	11.76	1.54	1.80	1.98	0.88	1.07	1.18
1700	20.33	21.08	21.69	0.81	1.05	1.22	0.33	0.53	0.63
1790	35.00	36.17	37.20	0.65	0.86	1.02	0.21	0.41	0.54
1800	37.02	38.33	39.51	0.61	0.84	0.99	0.21	0.42	0.52
1900	36.10	36.07	35.93	0.56	0.77	0.92	0.18	0.37	0.48
2000	32.16	32.29	32.49	0.53	0.73	0.89	0.17	0.36	0.48
2100	31.71	31.86	32.01	0.56	0.77	0.95	0.19	0.37	0.50
2200	31.99	32.28	32.51	0.61	0.84	1.01	0.18	0.38	0.50
2300	32.71	33.10	33.29	0.67	0.91	1.10	0.15	0.37	0.48
2400	33.78	34.19	34.77	0.65	0.89	1.13	0.16	0.35	0.52
2500	34.73	34.85	35.29	0.65	0.94	1.17	0.16	0.38	0.53
2600	37.04	36.72	37.59	0.70	1.01	1.21	0.18	0.40	0.54
2700	40.36	40.82	40.97	0.76	1.07	1.29	0.11	0.36	0.51
2800	50.15	48.29	49.24	0.79	1.10	1.32	0.15	0.39	0.56
2900	66.54	54.33	56.96	0.75	1.06	1.24	0.13	0.40	0.56
3000	43.55	42.67	42.25	0.84	1.07	1.27	0.12	0.42	0.58

REV. X1

JCBP-900+

090402

Page 1 of 2



IF/RF MICROWAVE COMPONENTS • ISO 9001 ISO 14001 AS 9100 CERTIFIED • RoHS compliant

P.O. Box 350166, Brooklyn, New York 11235-0003 (718) 934-4500 Fax (718) 332-4661



The Design Engineers Search Engine finds the model you need, Instantly • For detailed performance specs & shopping online see



# Surface Mount Band Pass Filter

# JCBP-900+

## Typical Performance Data

FREQ. (MHz)	GROUP DELAY (nsec)		
	@ -40° C	@ +25° C	@ +85° C
450	8.49	8.45	8.45
452	8.54	8.49	8.44
453	8.57	8.53	8.43
454	8.54	8.42	8.39
455	8.52	8.43	8.34
457	8.48	8.34	8.23
458	8.39	8.24	8.15
459	8.34	8.25	8.12
460	8.27	8.14	8.00
462	8.04	7.92	7.79
463	7.97	7.81	7.71
464	7.85	7.69	7.56
465	7.75	7.60	7.47
467	7.53	7.37	7.24
468	7.35	7.23	7.09
469	7.25	7.08	6.95
470	7.07	6.93	6.82
472	6.81	6.65	6.57
473	6.70	6.55	6.47
474	6.49	6.41	6.30
475	6.42	6.30	6.23
477	6.14	6.08	5.96
478	6.00	5.94	5.82
479	5.96	5.82	5.77
480	5.78	5.71	5.62
482	5.59	5.48	5.46
483	5.50	5.40	5.35
484	5.40	5.32	5.27
485	5.31	5.22	5.17
487	5.14	5.07	5.00
488	5.06	4.99	4.95
489	4.93	4.92	4.84
490	4.86	4.83	4.77
500	3.97	3.97	3.95
550	3.22	3.23	3.20
600	2.40	2.39	2.38
650	1.95	1.95	1.94
700	1.70	1.69	1.69
750	1.53	1.52	1.53
800	1.42	1.41	1.41
850	1.34	1.33	1.33
900	1.27	1.27	1.27
950	1.22	1.21	1.21
1000	1.19	1.18	1.18
1050	1.18	1.18	1.18
1100	1.19	1.19	1.19
1150	1.22	1.22	1.23
1200	1.27	1.27	1.27
1250	1.33	1.32	1.33
1300	1.48	1.48	1.51
1310	1.50	1.51	1.51
1320	1.45	1.44	1.44
1330	1.41	1.40	1.39
1340	1.48	1.47	1.48
1350	1.62	1.59	1.60

REV. X1  
 JCBP-900+  
 090402  
 Page 2 of 2



IF/RF MICROWAVE COMPONENTS • ISO 9001 ISO 14001 AS 9100 CERTIFIED • RoHS compliant  
 P.O. Box 350166, Brooklyn, New York 11235-0003 (718) 934-4500 Fax (718) 332-4661



The Design Engineers Search Engine finds the model you need, Instantly • For detailed performance specs & shopping online see



## Typical Performance Curves

### INSERTION LOSS vs. TEMPERATURE

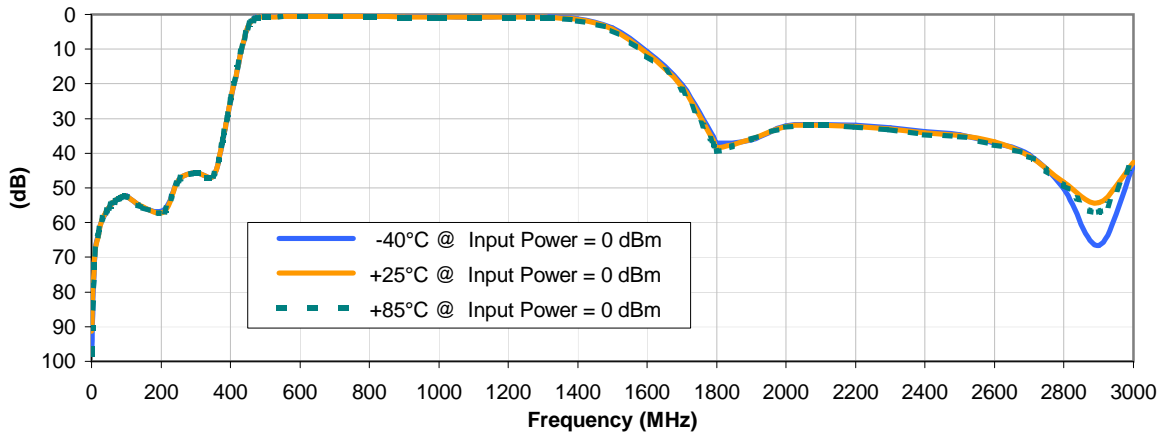

### INPUT RETURN LOSS vs. TEMPERATURE

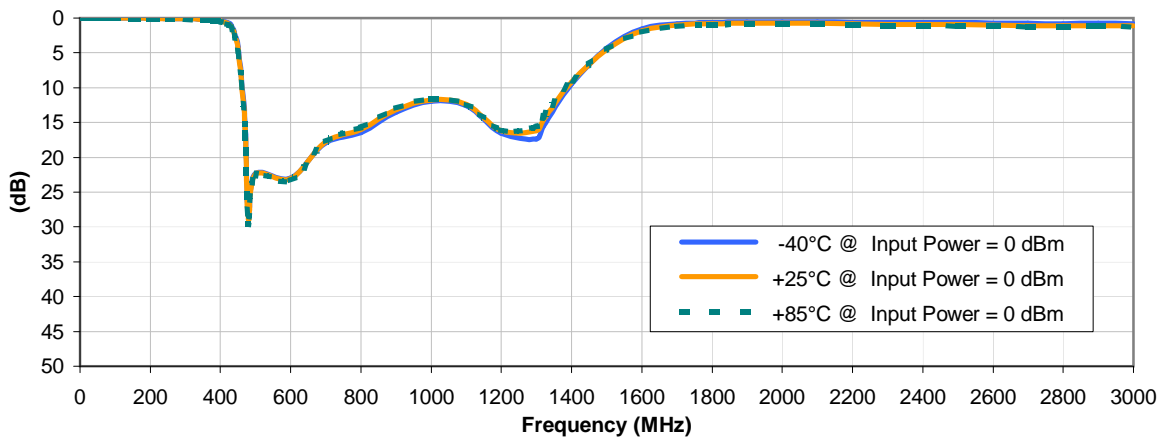

### OUTPUT RETURN LOSS vs. TEMPERATURE

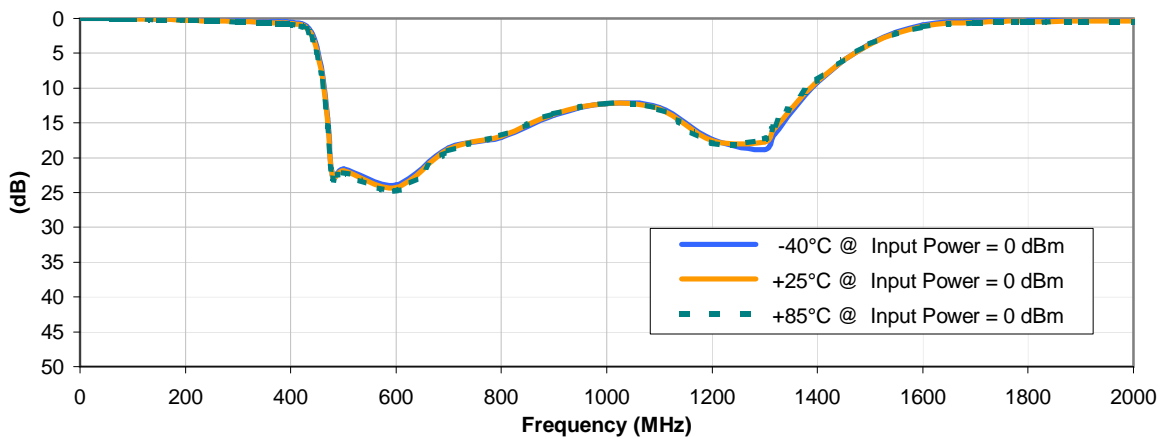

## Typical Performance Curves

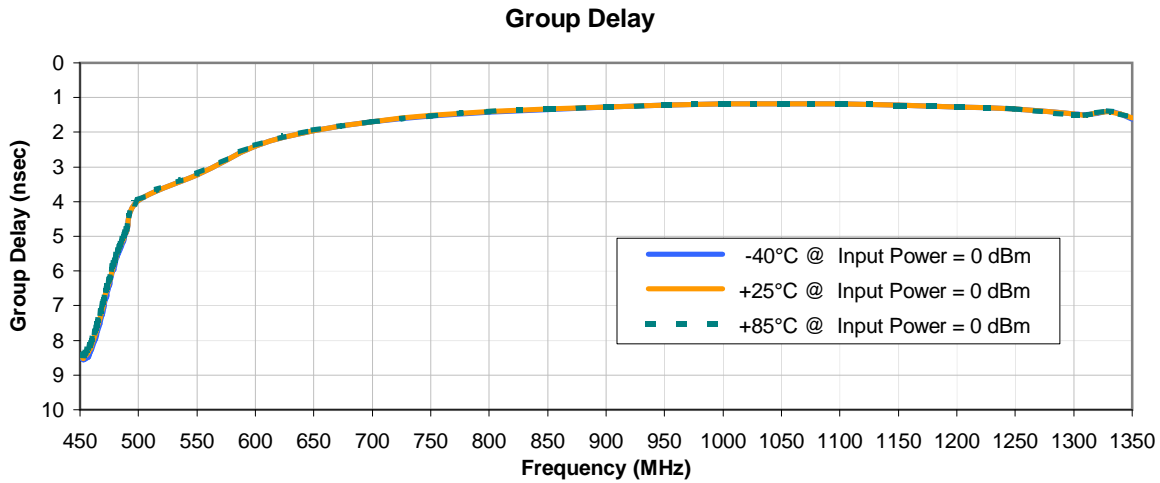

## Outline Dimensions

BG291

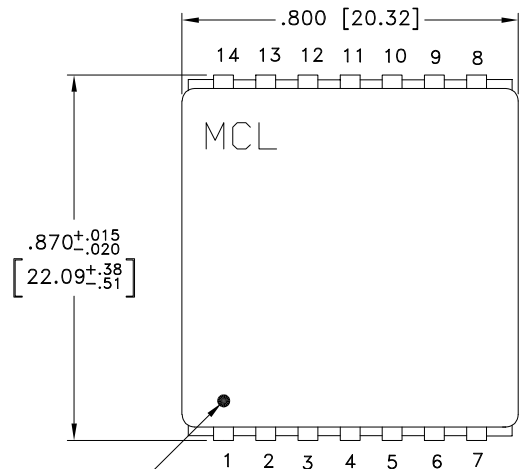

TOP VIEW

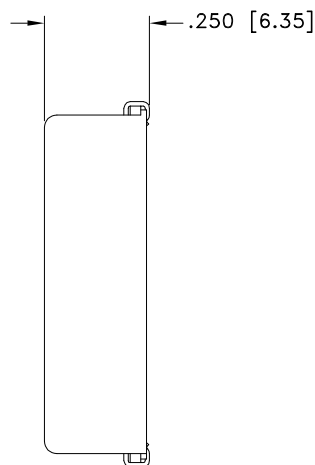

SIDE VIEW



SIDE VIEW

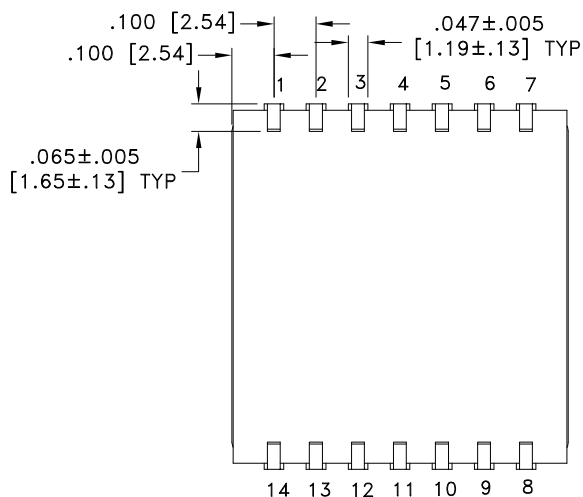

BOTTOM VIEW

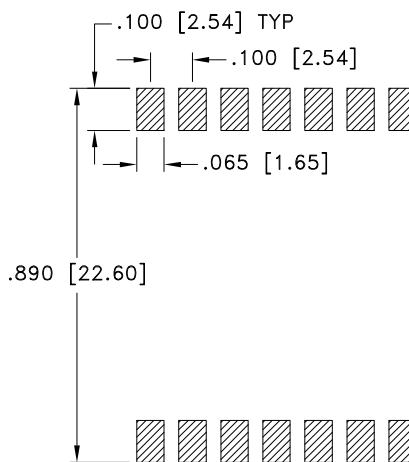

SUGGESTED LAYOUT FOR PCB LAND PATTERN (TOL ±.002)

 DENOTES METALLIZATION

Weight: 4 gram

Dimensions are in inches[mm]. Tolerances: 2PL±0.03[0.76]; 3 PL± 0.015 [0.381] inches[mm], unless otherwise specified

Notes:

1. Case material: Copper-Nickel alloy.
2. Base material: Printed wiring laminate.
3. Termination finish:

For RoHS Case Styles: Tin plate over Nickel plate. All models, (+) suffix.  
 For RoHS-5 Case Styles: Tin-Lead plate. All models, no (+) suffix.



P.O. Box 350166, Brooklyn, New York 11235-0003 (718) 934-4500 Fax (718) 332-4661 For detailed performance specs & shopping online see Mini-Circuits web site



The Design Engineers Search Engine Provides ACTUAL Data Instantly From MINI-CIRCUITS At: [www.minicircuits.com](http://www.minicircuits.com)

RF/IF MICROWAVE COMPONENTS

# Tape & Reel Packaging TR-F21

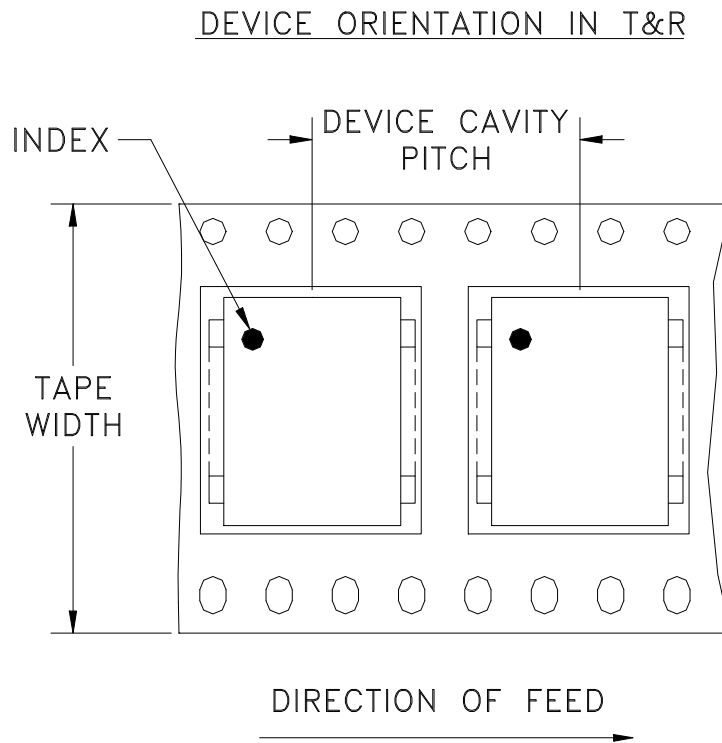

<b>Tape Width, mm</b>	<b>Device Cavity Pitch, mm</b>	<b>Reel Size, inches</b>	<b>Devices per Reel</b>
32	32	13	200

Mini-Circuits carrier tape materials provide protection from ESD (Electro-Static Discharge) during handling and transportation. Tapes are static dissipative and comply with industry standards EIA-481/EIA-541.

Go to: [www.minicircuits.com/pages/pdfs/tape.pdf](http://www.minicircuits.com/pages/pdfs/tape.pdf)



INTERNET <http://www.minicircuits.com>

P.O. Box 350166, Brooklyn, New York 11235-0003 (718) 934-4500 Fax (718) 332-4661

Distribution Centers NORTH AMERICA 800-654-7949 • 417-335-5935 • Fax 417-335-5945 • EUROPE 44-1252-832600 • Fax 44-1252-837010

Mini-Circuits ISO 9001 & ISO 14001 Certified

THIRD ANGLE PROJECTION

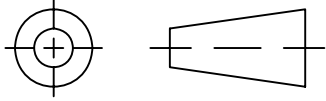

REVISIONS

REV	ECN No.	DESCRIPTION	DATE	DR	AUTH
OR	M110266	NEW RELEASE	03/07	DK	HH
OR	R68010	NEW RELEASE	03/07	DK	HH

**SUGGESTED MOUNTING CONFIGURATION  
FOR BG291 CASE STYLE, "sc" PIN CONNECTION.**

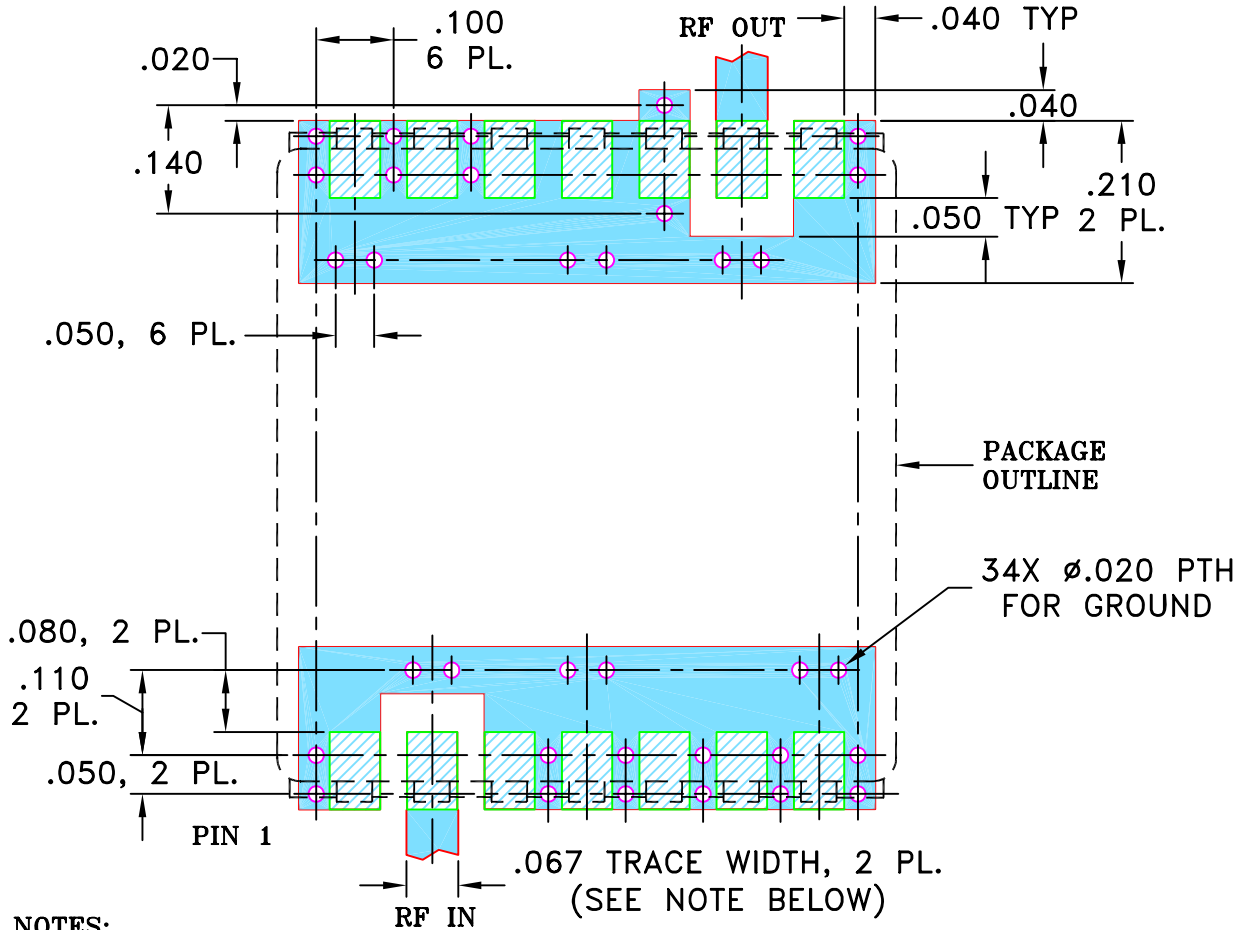

NOTES:

1. TRACE WIDTH IS SHOWN FOR ROGERS R04350B WITH DIELECTRIC THICKNESS  $.030" \pm .002"$ ; COPPER: 1/2 OZ. EACH SIDE. FOR OTHER MATERIALS TRACE WIDTH MAY NEED TO BE MODIFIED.
2. BOTTOM SIDE OF THE PCB IS CONTINUOUS GROUND PLANE.

 DENOTES PCB COPPER LAYOUT WITH SMOBC (SOLDER MASK OVER BARE COPPER)

 DENOTES COPPER LAND PATTERN FREE OF SOLDER MASK

UNLESS OTHERWISE SPECIFIED	INITIALS	DATE
DIMENSIONS ARE IN INCHES	DK	27 MAR 07
TOLERANCES ON: 2 PL DECIMALS $\pm$	HH	27 MAR 07
3 PL DECIMALS $\pm$ .005	HH	27 MAR 07
ANGLES $\pm$		
FRACTIONS $\pm$		

 **Mini-Circuits®** 13 Neptune Avenue  
Brooklyn NY 11235

PL, sc, BG291, JCBP-25, TB-442+

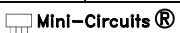
 Mini-Circuits®  
THIS DOCUMENT AND ITS CONTENTS ARE THE PROPERTY OF MINI-CIRCUITS. EXCEPT FOR USE EXPRESSLY GRANTED, IN WRITING, TO ITS VENDORS, VENDEE AND THE UNITED STATES GOVERNMENT, MINI-CIRCUITS RESERVES ALL PROPRIETARY DESIGN, USE, MANUFACTURING AND REPRODUCTION RIGHTS THERETO. THESE CONTENTS SHALL NOT BE USED, DUPLICATED OR DISCLOSED TO ANY OUTSIDE PARTY, IN WHOLE OR IN PART, WITHOUT WRITTEN PERMISSION OF MINI-CIRCUITS.  
ASHEETA1.DWG REV:A DATE:01/12/95

SIZE	CODE IDENT	DRAWING NO:	REV:
A	15542	98-PL-269	OR
FILE:	98PL269	SCALE: 4:1	SHEET: 1 OF 1



# Evaluation Board and Circuit

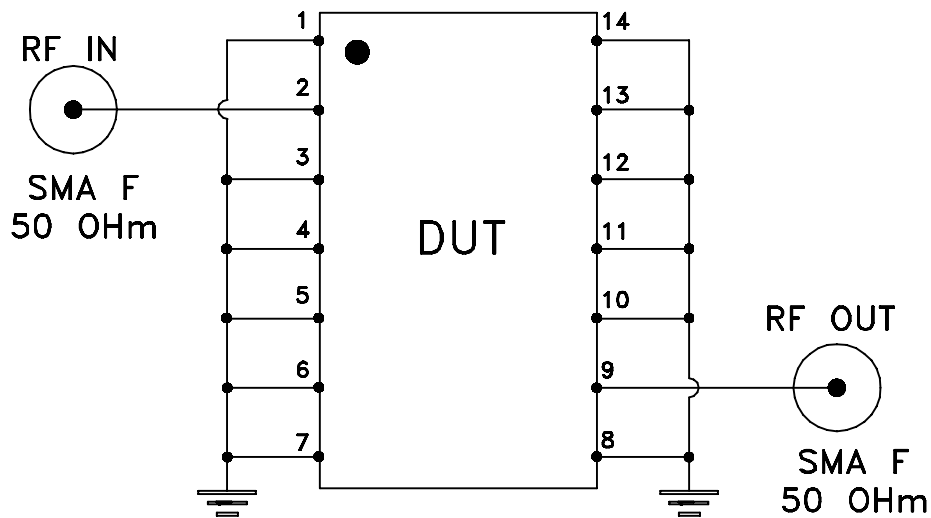
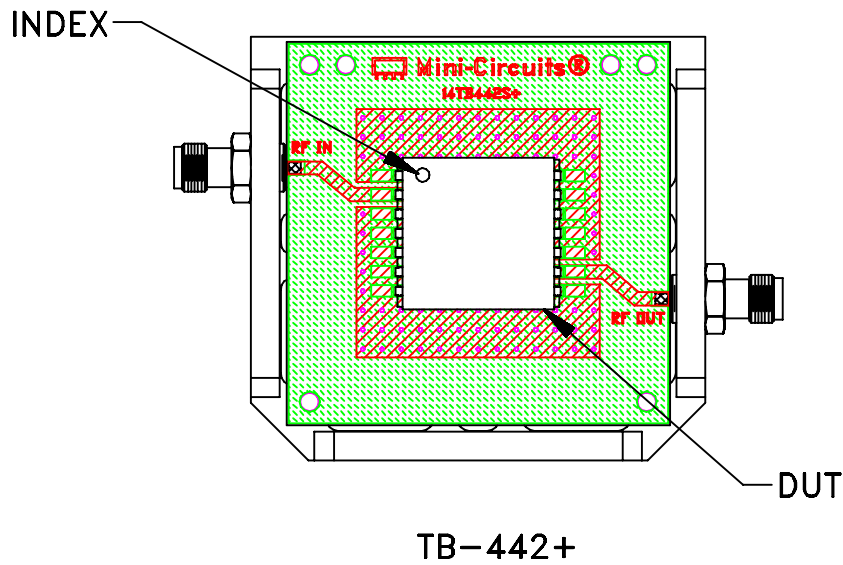

Schematic Diagram

## Notes:

1. 50 Ohm SMA Female connectors.
2. PCB Material: ROGERS R04350 or equivalent,  
Dielectric Constant=3.48, Thickness=.030 inch.

 **Mini-Circuits®**

All Mini-Circuits products are manufactured under exacting quality assurance and control standards, and are capable of meeting published specifications after being subjected to any or all of the following physical and environmental test.

Specification	Test/Inspection Condition	Reference/Spec
Operating Temperature	-40° to 85°C Ambient Environment	Individual Model Data Sheet
Storage Temperature	-55° to 100° C Ambient Environment	Individual Model Data Sheet
Humidity	90 to 95% RH, 240 hours, 50°C	MIL-STD-202, Method 103, Condition A, Except 50°C and end-point electrical test done within 12 hours
Thermal Shock	-55° to 100°C, 100 cycles	MIL-STD-202, Method 107, Condition A-3, except +100°C
Solder Reflow Heat	Sn-Pb Eutetic Process: 225°C peak Pb-Free Process 245° - 250°C peak	J-STD-020, Table 4-1, 4-2 and 5-2, Figure 5-1
Solderability	10X Magnification	J-STD-002, 95% Coverage
Vibration (High Frequency)	20g peak, 10-2000 Hz, 12 times in each of three perpendicular directions (total 36)	MIL-STD-202, Method 204, Condition D
Mechanical Shock	50g, 11 ms, 1/2-sine, 18 shocks: 3 each direction, each of 3 axes	MIL-STD-202, Method 213, Condition A
Marking Resistance to Solvents	Isopropyl alcohol + mineral spirits at 25°C; terpene defluxer at 25°C; distilled water + proylene glycol monomethyl ether + monoethanolamine at 63°C to 70°C	MIL-STD-202, Method 215