



LTCC SURFACE MOUNT

High Pass Filter

HFHKI-3800+

50Ω 4250 to 14000 MHz

THE BIG DEAL

- Insertion Loss, Typ. 1 dB
- Strong Stopband Rejection
- Ultra-Wide Passband, 4250 to 14000 MHz
- 1210 SMT Footprint
- Integrated CPW Interposer for Easy SMT Integration
- Power Handling: 6 W
- Protected by US Patents 11,638,370 and 11,744,057

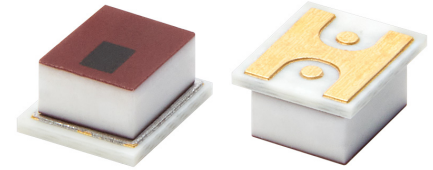

Generic photo used for illustration purposes only

APPLICATIONS

- X-Band and Ku-Band Radar Systems
- Ku-Band SATCOM Terminals
- Test and Measurement Equipment
- EW and Spectrum Monitoring

FUNCTIONAL DIAGRAM

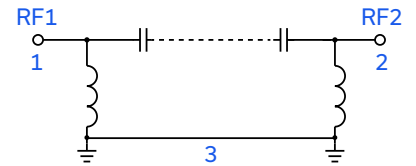

PRODUCT OVERVIEW

The HFHKI-3800+ is 4250 to 14000 MHz LTCC high pass filter featuring an integrated interposer for seamless CPWG interface compatibility. This design supports direct connection to planar transmission lines. The extended upper-frequency range makes it well suited for microwave and Ku-band applications requiring wide instantaneous bandwidth and reliable suppression of lower-frequency signals. Its SMT form factor enables compact implementations, and the ceramic construction provides stable, repeatable electrical performance across temperature and frequency.

ELECTRICAL SPECIFICATIONS^{1,2,3} AT +25 °C, Z₀ = 50 Ω

| Parameter | | F# | Frequency (MHz) | Min. | Typ. | Max. | Units |
|-----------|----------------------------|----------------|-----------------|------|------|------|-------|
| Passband | Insertion Loss | F4-F5 | 4250- 6000 | — | 1.9 | 2.5 | dB |
| | | F5-F6 | 6000-12000 | — | 1 | 1.7 | |
| | | F6-F7 | 12000-14000 | — | 1.2 | 2.6 | |
| Passband | Return Loss | F4-F5 | 4250- 6000 | — | 11 | — | dB |
| | | F5-F6 | 6000-12000 | — | 11 | — | |
| | | F6-F7 | 12000-14000 | — | 20 | — | |
| Stopband | Rejection | DC-F1 | DC-1300 | 58 | 68 | — | dB |
| | | F1-F2 | 1300-2200 | 36 | 46 | — | |
| | | F2-F3 | 2200-2950 | — | 23 | — | |
| | Freq. Cut-Off ⁴ | F _c | 3875 | — | 3 | — | dB |

1. Tested on Evaluation Board P/N TB-HFHKI-3800C+ with the connector and feedline effects de-embedded using the 2X Thru IEEE P370 method.
2. This filter is bi-directional RF1 and RF2 ports may be interchanged, see S-Parameters for actual performance.
3. This component should not be used as a DC-block. In applications where DC voltage and/or current is present at either the input or output ports, external DC blocking capacitors are required.
4. Typical variation ± 5 %

ABSOLUTE MAXIMUM RATINGS⁵

| | |
|--------------------------|-------------------|
| Operating Temperature | -55 °C to +125 °C |
| Storage Temperature | -55 °C to +125 °C |
| Input Power ⁶ | 6 W at 25 °C |

5. Permanent damage may occur if any of these limits are exceeded.
6. Power rating applies only to signals within the passband. Power rating above +25°C operating temperature decreases linearly to 1 W at +125°C.

TYPICAL FREQUENCY RESPONSE

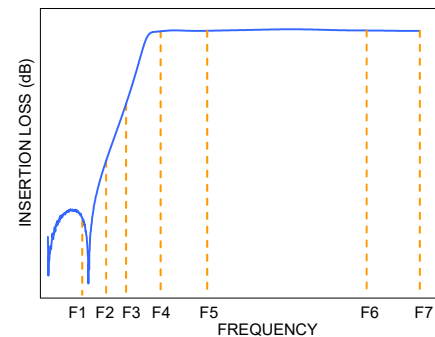

REV. OR
ECO-029508
HFHKI-3800+
MCL NY
260512





LTCC SURFACE MOUNT

High Pass Filter

HFHKI-3800+

Mini-Circuits

50Ω 4250 to 14000 MHz

TYPICAL PERFORMANCE GRAPHS

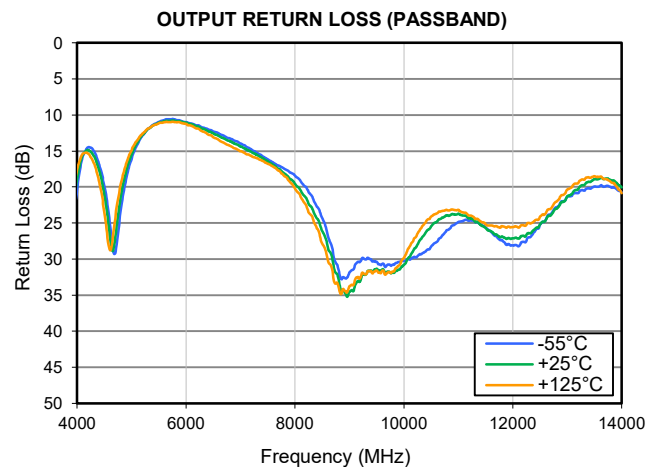
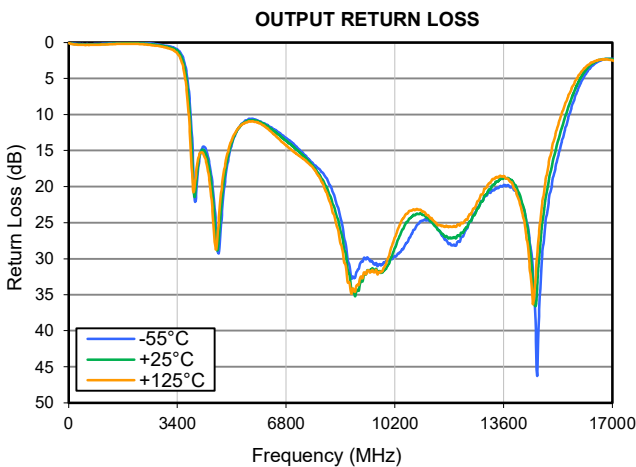
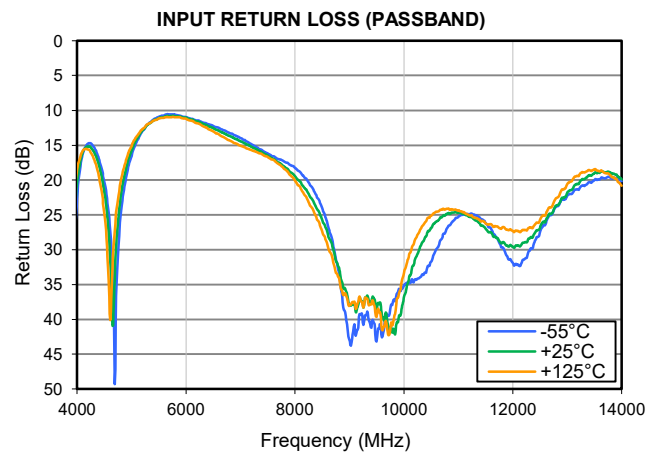
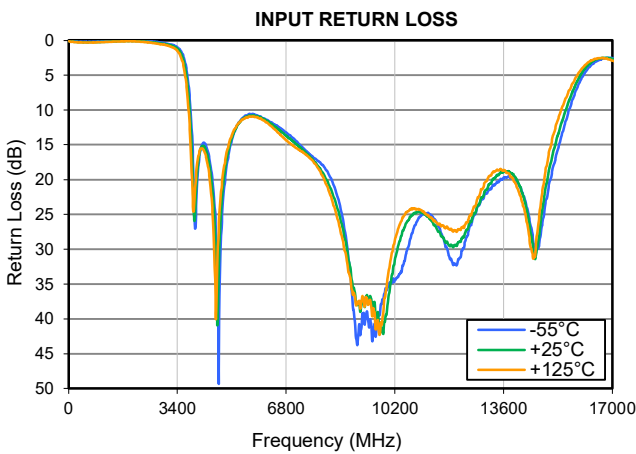
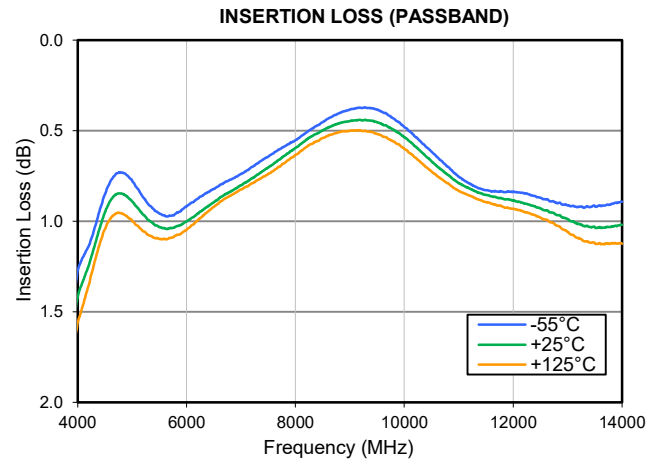
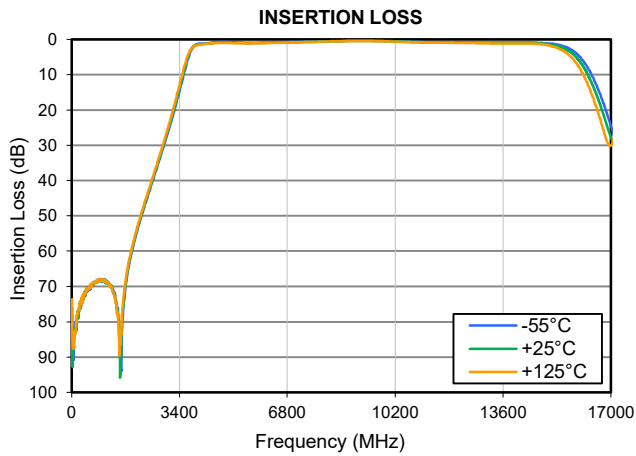



LTCC SURFACE MOUNT

High Pass Filter

HFHKI-3800+

Mini-Circuits

50Ω 4250 to 14000 MHz

FUNCTIONAL DIAGRAM

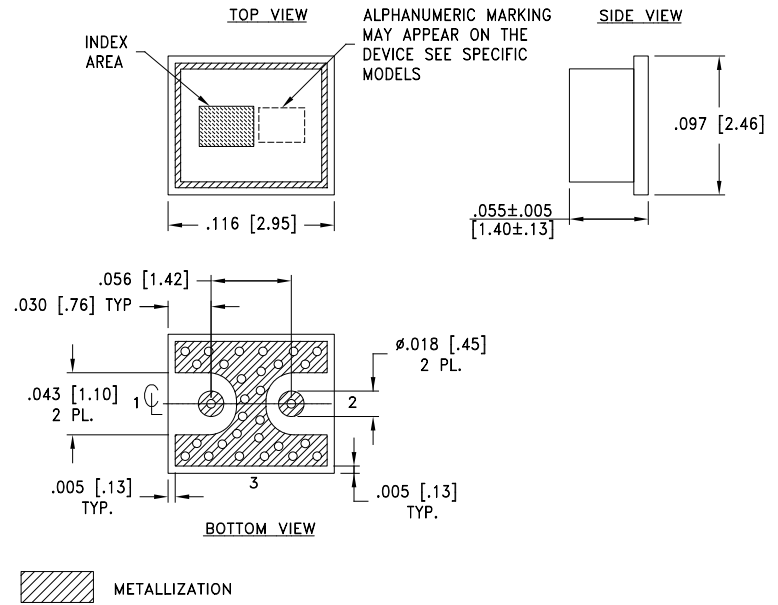

Figure 1. HFHKI-3800+ Functional Diagram

PAD DESCRIPTION

| Function | Pad Number | Description |
|------------------|------------|---|
| RF1 ² | 1 | Connects to RF Input Port |
| RF2 ² | 2 | Connects to RF Output Port |
| GROUND | 3 | Connects to Ground on PCB, (See drawing PL-837) |

CASE STYLE DRAWING



Weight: .021 grams
Dimensions are in inches [mm]. Tolerances: 2 Pl. ±.01; 3 Pl. ±.005 Inches

SUGGESTED PCB LAYOUT (PL-837)

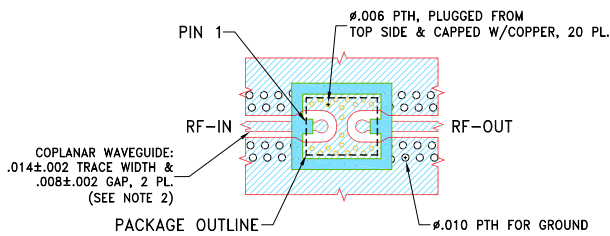

STACK-UP DIAGRAM

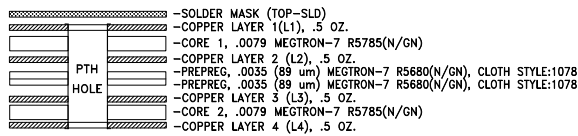

- TOTAL FINISHED THICKNESS 0.026±.004.
- PTH PRESENT FROM COPPER LAYER 1 TO COPPER LAYER 4.
- INDICATED ON TOP VIEW PTH'S ARE PLUGGED WITH EPOXY AND CAPPED WITH COPPER FROM TOP SIDE.
- L2, L3, AND L4 ARE CONTINUOUS GROUND PLANES.

NOTES:

- PCB IS MULTILAYER PCB, SEE STACK-UP DIAGRAM.
- TRACE WIDTH & GAP ARE SHOWN FOR MEGTRON-7 R5785(N/GN) WITH DIELECTRIC THICKNESS .0079". COPPER: .5 OZ. EACH LAYER. FOR OTHER MATERIALS TRACE WIDTH & GAP MAY NEED TO BE MODIFIED.
- LAYERS L2, L3 & L4 OF PCB ARE CONTINUOUS GROUND PLANES.

- DENOTES PCB COPPER LAYOUT WITH SMOBC (SOLDER MASK OVER BARE COPPER).
- DENOTES COPPER LAND PATTERN FREE OF SOLDER MASK.

PRODUCT MARKING*: J4

*Marking may contain other features or characters for internal lot control.

Figure 2. Suggested PCB Layout



LTCC SURFACE MOUNT

High Pass Filter

HFHKI-3800+

50Ω 4250 to 14000 MHz

ADDITIONAL DETAILED INFORMATION IS AVAILABLE ON OUR DASHBOARD

[CLICK HERE](#)

| | |
|---------------------------------|---|
| Performance Data & Graphs | Data Graphs S-Parameter (S2P Files) Data Set (.zip file) De-embedded to device pads |
| Case Style | NM3723-1 Lead Finish: Gold Plate over Nickel Plate |
| RoHS/REACH Status | Compliant |
| Tape and Reel | F66-3 |
| Suggested Layout for PCB Design | PL-837 |
| Evaluation Board | TB-HFHKI-3800C+ Gerber File |
| Environmental Rating | ENV06T10 |

NOTES

- A. Performance and quality attributes and conditions not expressly stated in this specification document are intended to be excluded and do not form a part of this specification document.
- B. Electrical specifications and performance data contained in this specification document are based on Mini-Circuits' applicable established test performance criteria and measurement instructions.
- C. The parts covered by this specification document are subject to Mini-Circuits' standard limited warranty and terms and conditions (collectively, "Standard Terms"); Purchasers of this part are entitled to the rights and benefits contained therein. For a full statement of the standard terms and the exclusive rights and remedies thereunder, please visit Mini-Circuits' website at www.minicircuits.com/terms/viewterm.html



Typical Performance Data

| FREQUENCY (MHz) | INSERTION LOSS (dB) | | | INPUT RETURN LOSS (dB) | | | OUTPUT RETURN LOSS (dB) | | |
|--------------------|------------------------|--------|---------|---------------------------|--------|---------|----------------------------|--------|---------|
| | @-55°C | @+25°C | @+125°C | @-55°C | @+25°C | @+125°C | @-55°C | @+25°C | @+125°C |
| 10.00 | 75.91 | 78.26 | 73.62 | 0.07 | 0.12 | 0.15 | 0.09 | 0.15 | 0.04 |
| 50.00 | 86.13 | 84.12 | 87.57 | 0.11 | 0.16 | 0.19 | 0.12 | 0.19 | 0.07 |
| 500.00 | 70.90 | 70.94 | 70.65 | 0.19 | 0.25 | 0.29 | 0.28 | 0.29 | 0.22 |
| 1000.00 | 68.05 | 68.45 | 68.30 | 0.17 | 0.23 | 0.27 | 0.25 | 0.27 | 0.19 |
| 2000.00 | 56.41 | 56.07 | 55.53 | -0.01 | 0.10 | 0.16 | 0.11 | 0.16 | 0.01 |
| 3000.00 | 27.40 | 26.90 | 26.21 | 0.40 | 0.53 | 0.64 | 0.53 | 0.64 | 0.42 |
| 3500.00 | 11.19 | 10.41 | 9.51 | 1.43 | 1.76 | 2.23 | 1.75 | 2.23 | 1.43 |
| 4000.00 | 1.28 | 1.42 | 1.56 | 22.66 | 20.44 | 18.55 | 18.96 | 18.55 | 20.45 |
| 4500.00 | 0.85 | 0.95 | 1.04 | 20.20 | 21.70 | 24.67 | 21.02 | 24.67 | 19.77 |
| 5000.00 | 0.78 | 0.89 | 1.00 | 16.50 | 15.79 | 15.09 | 15.52 | 15.09 | 16.11 |
| 5500.00 | 0.96 | 1.03 | 1.10 | 10.91 | 11.10 | 11.18 | 11.11 | 11.18 | 10.97 |
| 6000.00 | 0.92 | 1.00 | 1.05 | 10.95 | 11.04 | 11.20 | 11.06 | 11.20 | 10.99 |
| 6500.00 | 0.82 | 0.89 | 0.92 | 12.20 | 12.53 | 12.99 | 12.56 | 12.99 | 12.26 |
| 7000.00 | 0.74 | 0.80 | 0.83 | 13.95 | 14.43 | 15.06 | 14.38 | 15.06 | 13.96 |
| 7500.00 | 0.64 | 0.70 | 0.74 | 16.17 | 0.70 | 16.69 | 16.14 | 16.43 | 16.74 |
| 8000.00 | 0.55 | 0.59 | 0.63 | 18.21 | 19.43 | 20.06 | 19.54 | 20.06 | 18.42 |
| 8500.00 | 0.45 | 0.55 | 0.57 | 22.44 | 21.98 | 21.48 | 23.53 | 23.62 | 23.34 |
| 9000.00 | 0.38 | 0.45 | 0.50 | 42.88 | 37.80 | 37.97 | 34.55 | 37.97 | 31.85 |
| 9500.00 | 0.38 | 0.45 | 0.52 | 43.20 | 38.61 | 39.65 | 31.32 | 39.65 | 30.37 |
| 10000.00 | 0.48 | 0.54 | 0.60 | 35.08 | 36.94 | 33.33 | 30.78 | 33.33 | 30.23 |
| 10500.00 | 0.62 | 0.67 | 0.73 | 31.73 | 26.89 | 25.11 | 25.48 | 25.11 | 28.29 |
| 11000.00 | 0.76 | 0.79 | 0.83 | 25.26 | 24.65 | 24.35 | 23.70 | 24.35 | 24.81 |
| 11500.00 | 0.83 | 0.86 | 0.89 | 26.09 | 26.96 | 26.17 | 25.66 | 26.17 | 25.57 |
| 12000.00 | 0.84 | 0.88 | 0.93 | 31.89 | 29.55 | 27.31 | 27.11 | 27.31 | 28.10 |
| 12500.00 | 0.87 | 0.93 | 0.98 | 27.61 | 26.87 | 25.81 | 25.20 | 25.81 | 25.28 |
| 13000.00 | 0.91 | 0.99 | 1.06 | 22.24 | 21.83 | 20.57 | 21.30 | 20.57 | 21.36 |
| 13500.00 | 0.92 | 1.03 | 1.12 | 20.03 | 19.03 | 18.51 | 18.91 | 18.51 | 19.92 |
| 14000.00 | 0.89 | 1.02 | 1.12 | 20.16 | 19.88 | 20.81 | 20.05 | 20.81 | 20.71 |
| 14500.00 | 0.89 | 1.03 | 1.19 | 27.69 | 28.99 | 30.56 | 32.07 | 30.56 | 30.50 |
| 15000.00 | 1.12 | 1.33 | 1.64 | 21.38 | 19.18 | 16.68 | 19.60 | 16.68 | 22.58 |
| 16000.00 | 4.75 | 6.02 | 7.92 | 5.79 | 5.00 | 4.35 | 4.95 | 4.35 | 5.75 |
| 17000.00 | 24.48 | 27.79 | 30.08 | 2.56 | 2.66 | 2.90 | 2.33 | 2.90 | 2.25 |

Typical Performance Data

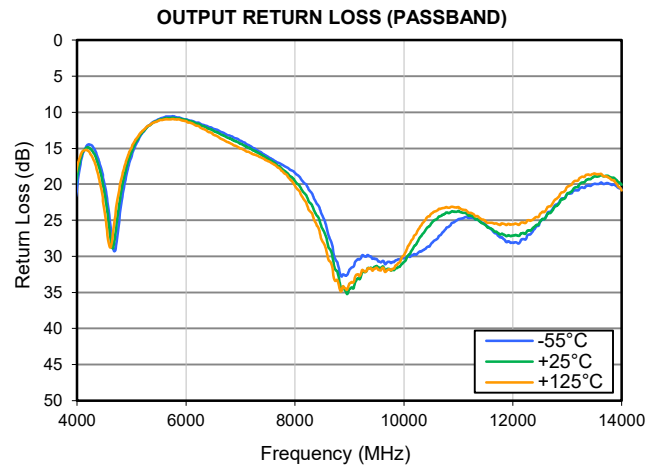
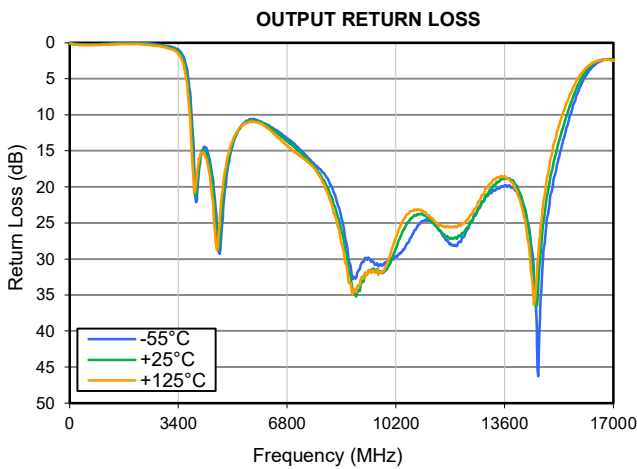
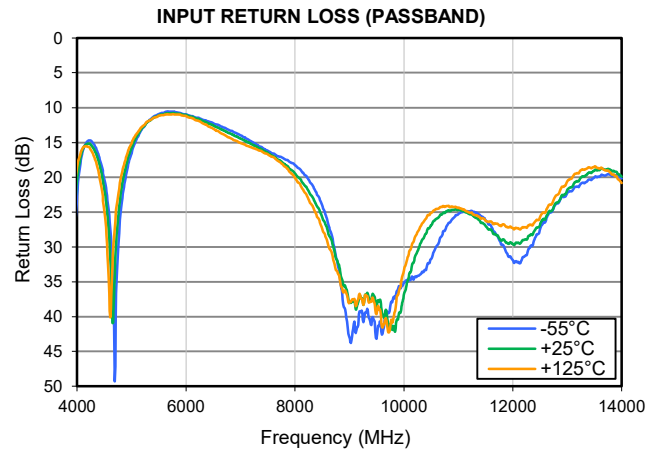
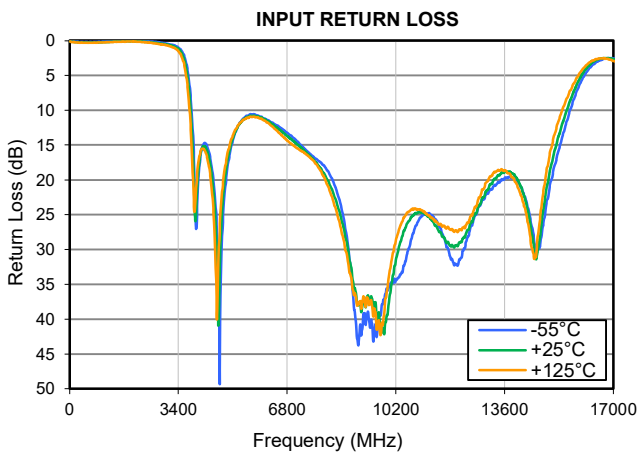
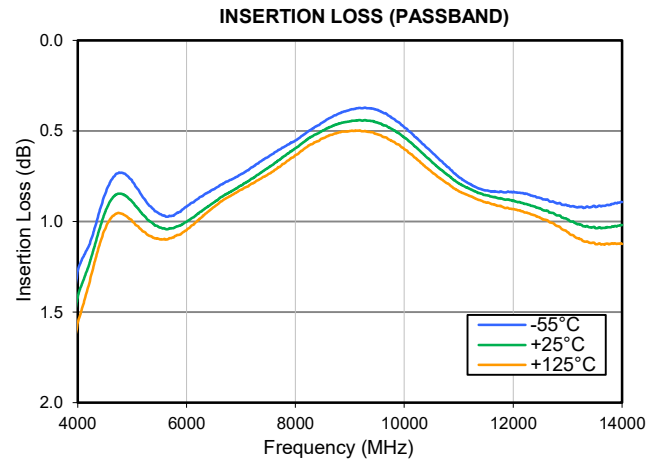
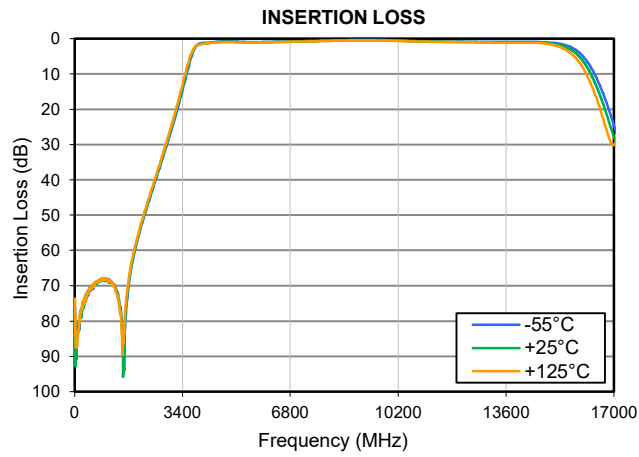

Case Style

NM

Outline Dimensions

NM3723-1

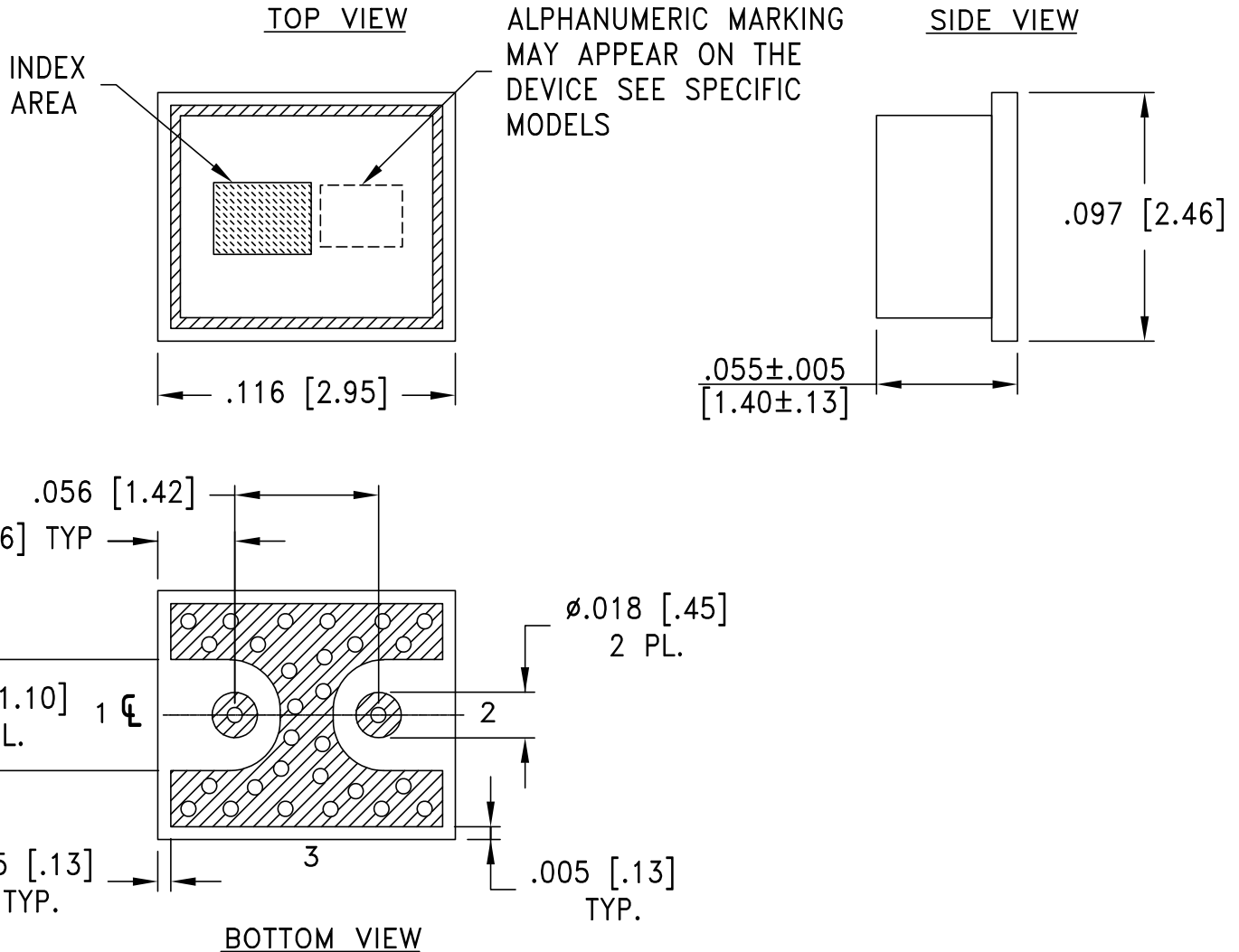

METALLIZATION

Weight: .021 grams

Dimensions are in inches [mm]. Tolerances: 2 Pl. ±.01; 3 Pl. ±.005 inches

Notes:

1. Case material: LTCC on printed circuit board base.
2. Termination Finish: **as shown below or indicated on Data Sheet.**
For RoHS Case Styles: Gold Plate over Nickel plate. All models, (+) suffix.

Mini-Circuits[®]

INTERNET <http://www.minicircuits.com>

P.O. Box 350166, Brooklyn, New York 11235-0003 (718) 934-4500 Fax (718) 332-4661

Distribution Centers NORTH AMERICA 800-654-7949 • 417-335-5935 • Fax 417-335-5945 • EUROPE 44-1252-832600 • Fax 44-1252-837010

Mini-Circuits ISO 9001 & ISO 14001 Certified

Tape & Reel Packaging TR-F66-3

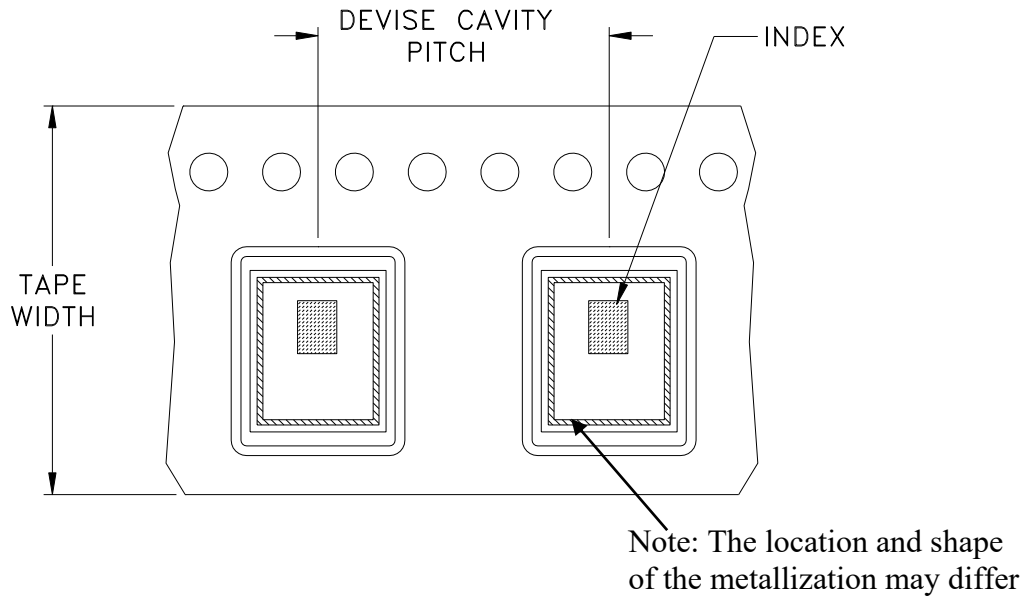

| Tape Width, mm | Device Cavity Pitch, mm | Reel Size, inches | Devices per Reel see note | |
|----------------|-------------------------|-------------------|------------------------------|------|
| 8 | 4 | 7 | Small quantity standard | 20 |
| | | | | 50 |
| | | | | 100 |
| | | | | 200 |
| | | | | 500 |
| | | 7 | Standard | 1000 |

Note: Please consult individual model data sheet to determine device per reel availability.

Mini-Circuits carrier tape materials provide protection from ESD (Electro-Static Discharge) during handling and transportation. Tapes are static dissipative and comply with industry standards EIA-481/EIA-541.

Go to: www.minicircuits.com/pages/pdfs/tape.pdf

Mini-Circuits[®]

INTERNET <http://www.minicircuits.com>

P.O. Box 350166, Brooklyn, New York 11235-0003 (718) 934-4500 Fax (718) 332-4661

Distribution Centers NORTH AMERICA 800-654-7949 • 417-335-5935 • Fax 417-335-5945 • EUROPE 44-1252-832600 • Fax 44-1252-837010

Mini-Circuits ISO 9001 & ISO 14001 Certified

THIRD ANGLE PROJECTION

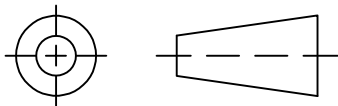

REVISIONS

| REV | ECN No. | DESCRIPTION | DATE | DR | AUTH |
|-----|------------|-------------|----------|-----|------|
| OR | ECO-026948 | NEW RELEASE | 09/15/25 | ITG | IL |
| | | | | | |
| | | | | | |

SUGGESTED MOUNTING CONFIGURATION
FOR NM3723-1 CASE STYLE

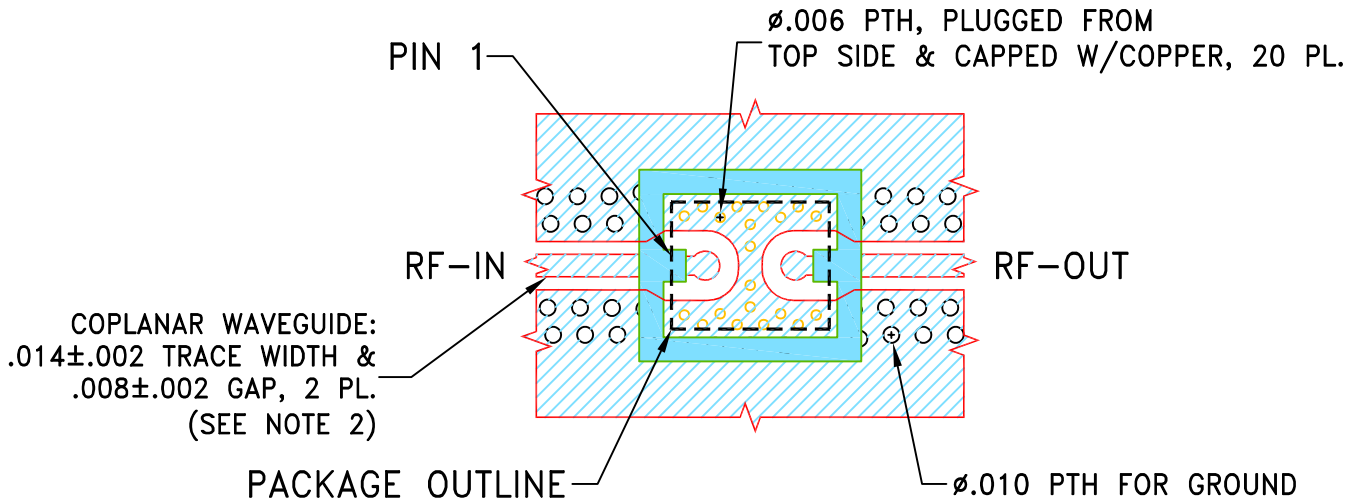

STACK-UP DIAGRAM

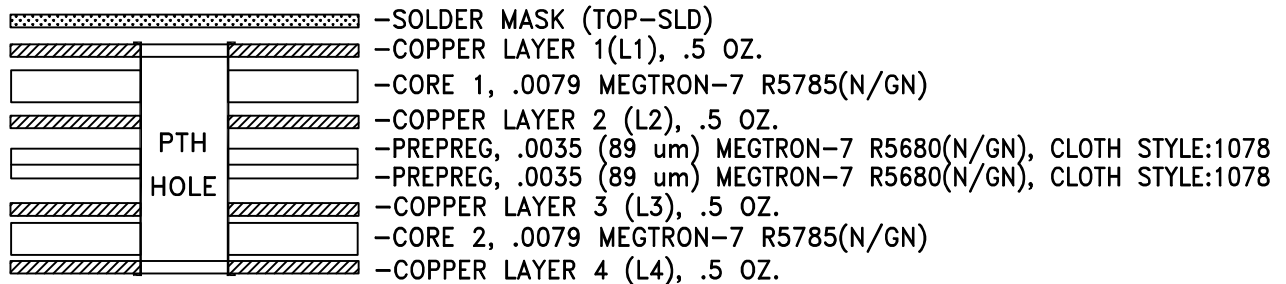

- TOTAL FINISHED THICKNESS 0.026±.004.
- PTH PRESENT FROM COPPER LAYER 1 TO COPPER LAYER 4.
- INDICATED ON TOP VIEW PTH's ARE PLUGGED WITH EPOXY AND CAPPED WITH COPPER FROM TOP SIDE.
- L2, L3, AND L4 ARE CONTINUOUS GROUND PLANES.

NOTES:

- PCB IS MULTILAYER PCB, SEE STACK-UP DIAGRAM.
- TRACE WIDTH & GAP ARE SHOWN FOR MEGTRON-7 R5785(N/GN) WITH DIELECTRIC THICKNESS .0079", COPPER: 1 OZ. EACH LAYER. FOR OTHER MATERIALS TRACE WIDTH & GAP MAY NEED TO BE MODIFIED.
- LAYERS L2, L3 & L4 OF PCB ARE CONTINUOUS GROUND PLANES.



DENOTES PCB COPPER LAYOUT WITH SMOBC (SOLDER MASK OVER BARE COPPER).



DENOTES COPPER LAND PATTERN FREE OF SOLDER MASK.

| UNLESS OTHERWISE SPECIFIED | INITIALS | DATE |
|----------------------------|----------|----------|
| DIMENSIONS ARE IN INCHES | ITG | 09/15/25 |
| TOLERANCES ON: | GF | 09/15/25 |
| 2 PL DECIMALS ± | APPROVED | 09/15/25 |
| 3 PL DECIMALS ± .005 | IL | 09/15/25 |
| ANGLES ± | | |
| FRACTIONS ± | | |



Mini-Circuits®

13 Neptune Avenue
Brooklyn NY 11235

PL, NM3723-1, TB-HFHKI-2200C+

| | | | |
|------------------|---------------------|--------------------------|------------|
| SIZE A | CODE IDENT 15542 | DRAWING NO: 98-PL-837 | REV: OR |
| FILE: 98PL837 | SCALE: 8:1 | SHEET: 1 OF 1 | |

Mini-Circuits®

THIS DOCUMENT AND ITS CONTENTS ARE THE PROPERTY OF MINI-CIRCUITS. EXCEPT FOR USE EXPRESSLY GRANTED, IN WRITING, TO ITS VENDORS, VENDEE AND THE UNITED STATES GOVERNMENT, MINI-CIRCUITS RESERVES ALL PROPRIETARY DESIGN, USE, MANUFACTURING AND REPRODUCTION RIGHTS THERETO. THESE CONTENTS SHALL NOT BE USED, DUPLICATED OR DISCLOSED TO ANY OUTSIDE PARTY, IN WHOLE OR IN PART, WITHOUT WRITTEN PERMISSION OF MINI-CIRCUITS.

Evaluation Board and Circuit

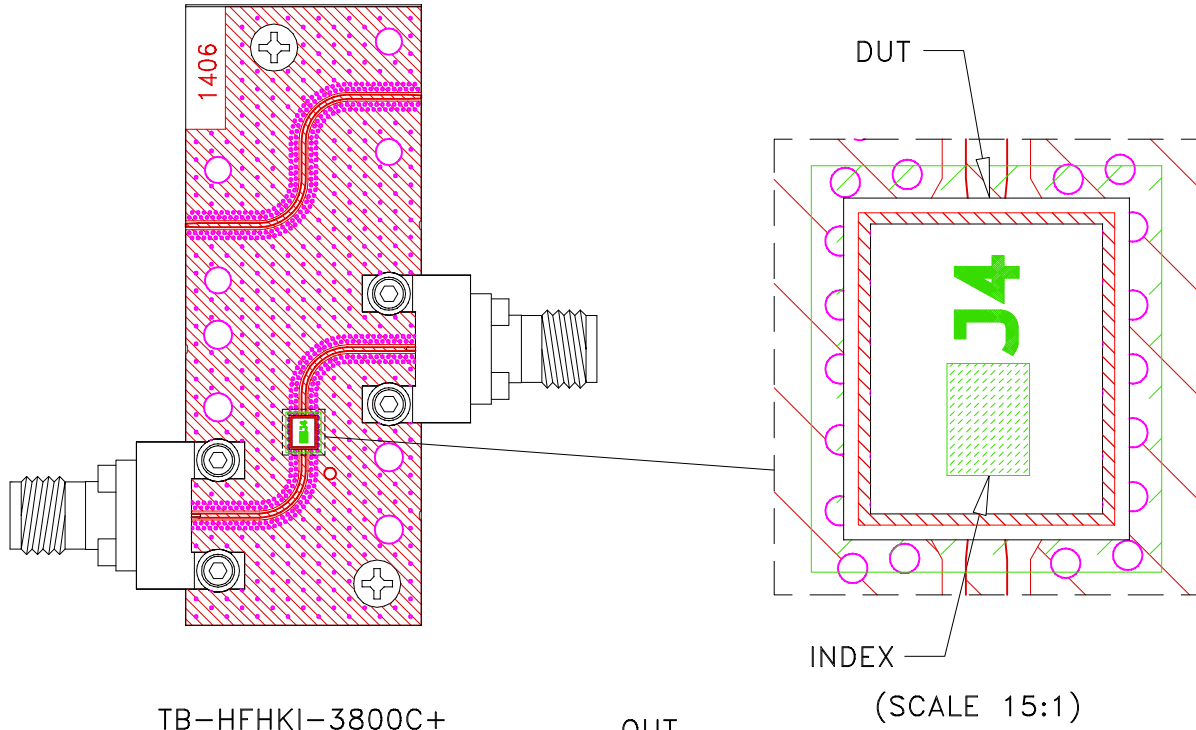

TB-HFHKI-3800C+

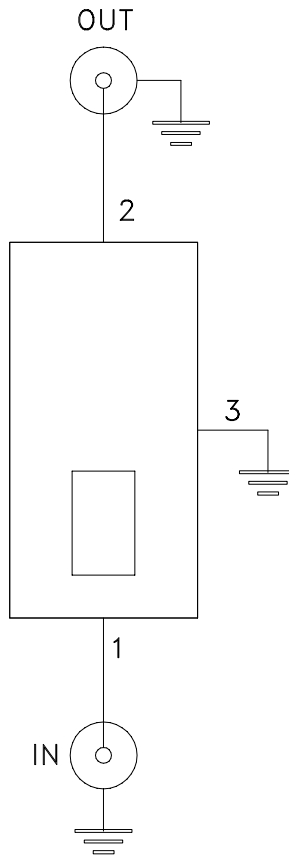

Schematic Diagram

1. 50 Ohm 2.4 mm Female end Launch connectors.
2. PCB Material: MEGTRON-7 R5785 (N or GN) or equivalent, Dielectric Constant= 3.37 Thickness=.0079 inch.

 **Mini-Circuits®**

All Mini-Circuits products are manufactured under exacting quality assurance and control standards, and are capable of meeting published specifications after being subjected to any or all of the following physical and environmental test.

| Specification | Test/Inspection Condition | Reference/Spec |
|-----------------------|--|--|
| Operating Temperature | -55° to 125° C Ambient Environment | Individual Model Data Sheet |
| Storage Temperature | -55° to 125° C Ambient Environment | Individual Model Data Sheet |
| Humidity | 90 to 95% RH, 240 hours, 50°C | MIL-STD-202, Method 103, Condition A, Except 50°C and end-point electrical test done within 12 hours |
| Solder Reflow Heat | Sn-Pb Eutectic Process 225°C peak Pb-Free Process 245° - 250°C peak | J-STD-020C, Table 4-1, 4-2 and 5-2, Figure 5-1 |
| Solderability | 10X Magnification | J-STD-002, Test B,B1, 95% Coverage |
| Thermal Shock | -55° to +125°C, 15 min dwell,250 cycles | MIL-STD-202, Method 107 |
| Bend Test | 1mm, deflection for 5 seconds Span of bending: 2.75" | -- |
| High Temp Storage | 125°C to 1000 Hrs | --- |