

# Ceramic High Pass Filter

## HFCG-1500+

50Ω      1600 to 6000 MHz

### The Big Deal

- Small size 2.0 mm x 1.25 mm
- Very good Power handling
- Ceramic construction



*Generic photo used for illustration purposes only*  
CASE STYLE: GE0805C-9

### Product Overview

HFCG-1500+ is a high pass filter with passband from 1600 MHz to 6000 MHz supporting a variety of applications. This model provides 2 dB typical insertion loss over a wide band due to strategically constructed layout. Housed in a tiny 0805 ceramic form factor with wraparound terminations, the filter is ideal for dense PCB layouts with minimal performance variation due to parasitics.

### Key Features

Feature	Advantages
Small size, 2.0 mm x 1.25 mm	Accommodates tight space requirements for dense PCB layouts.
Wrap around termination	Provides excellent solderability and easy visual inspection capability.
LTCC construction	Provides a rugged package that is well suited for tough environments including high humidity and high temperature extremes.
Wide pass band	This filter has a wide passband from 1.6 GHz to 6 GHz.

#### Notes

- A. Performance and quality attributes and conditions not expressly stated in this specification document are intended to be excluded and do not form a part of this specification document.  
B. Electrical specifications and performance data contained in this specification document are based on Mini-Circuit's applicable established test performance criteria and measurement instructions.  
C. The parts covered by this specification document are subject to Mini-Circuits standard limited warranty and terms and conditions (collectively, "Standard Terms"); Purchasers of this part are entitled to the rights and benefits contained therein. For a full statement of the Standard Terms and the exclusive rights and remedies thereunder, please visit Mini-Circuits' website at [www.minicircuits.com/MCLStore/terms.jsp](http://www.minicircuits.com/MCLStore/terms.jsp)



# Ceramic High Pass Filter

50Ω 1600 to 6000 MHz

## HFCG-1500+



Generic photo used for illustration purposes only  
CASE STYLE: GE0805C-9

**+RoHS Compliant**

The +Suffix identifies RoHS Compliance. See our web site for RoHS Compliance methodologies and qualifications

### Features

- Small size
- Temperature stable
- LTCC construction
- Very good power handling, 2.5W

### Applications

- Transmitters / Receivers
- Test and measurements
- Military applications
- Telecommunications and broadband wireless systems

### Electrical Specifications<sup>(1,2)</sup> at 25°C

Parameter		F#	Frequency (MHz)	Min.	Typ.	Max.	Unit
Stop Band	Rejection Loss	DC-F1	DC - 800	30	40	-	dB
		F1-F2	800 - 1000	28	35	-	dB
	Freq. Cut-Off	F3 *	1400	-	3.0	-	dB
Pass Band	Insertion Loss	F4-F5	1600 - 1900	-	2.0	-	dB
		F5-F6	1900 - 5000	-	1.0	1.7	dB
	Return Loss	F6-F7	5000 - 6000	-	2.0	-	dB
		F4-F7	1600 - 6000	-	10	-	dB

1 This component is not intended to act as a DC block. Please consult with Mini-Circuits for further details

2 Measured on Mini-Circuits Characterization Test Board TB-1104+

\* Typically, a ±5% frequency deviation from the stated value may occur on a unit-to-unit basis.

### Functional Schematic

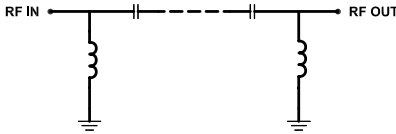

### Maximum Ratings

Operating Temperature	-55°C to 125°C
Storage Temperature	-55°C to 125°C
RF Power Input*	2.5W at 25°C

\*Passband rating, derate linearly to 0.5W at 125°C ambient

Permanent damage may occur if any of these limits are exceeded.

### Typical Performance Data at 25°C

Frequency (MHz)	Insertion Loss (dB)	Return Loss (dB)
10	71.90	0.15
100	54.69	0.17
800	37.88	0.43
1000	39.09	0.68
1120	31.27	1.11
1180	21.33	1.63
1200	18.52	1.91
1300	7.51	5.58
1400	3.05	13.94
1500	1.97	14.97
1600	1.59	13.17
1900	0.98	13.85
2000	0.81	16.07
2500	0.49	20.52
3000	0.49	14.74
4000	0.27	24.61
5000	0.43	13.02
5500	0.67	9.89
5700	0.78	9.12
6000	0.90	8.26

### Typical Frequency Response

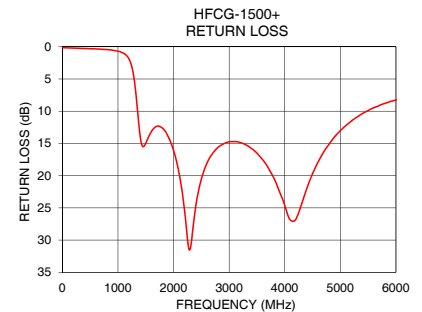
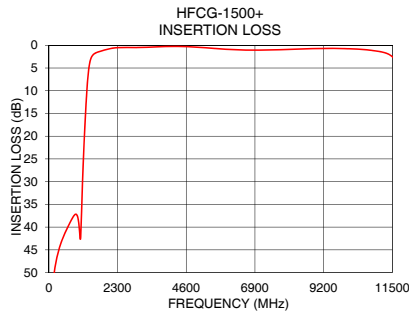
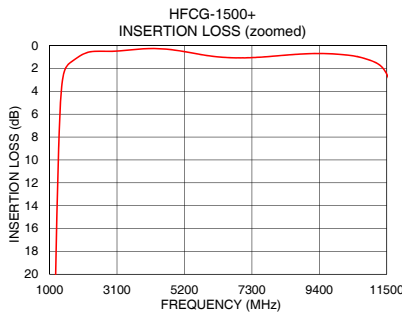
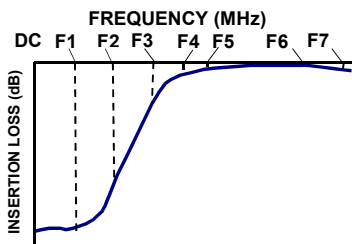

#### Notes

- Performance and quality attributes and conditions not expressly stated in this specification document are intended to be excluded and do not form a part of this specification document.
- Electrical specifications and performance data contained in this specification document are based on Mini-Circuit's applicable established test performance criteria and measurement instructions.
- The parts covered by this specification document are subject to Mini-Circuits standard limited warranty and terms and conditions (collectively, "Standard Terms"); Purchasers of this part are entitled to the rights and benefits contained therein. For a full statement of the Standard Terms and the exclusive rights and remedies thereunder, please visit Mini-Circuits' website at [www.minicircuits.com/MCLStore/terms.jsp](http://www.minicircuits.com/MCLStore/terms.jsp)



[www.minicircuits.com](http://www.minicircuits.com) P.O. Box 350166, Brooklyn, NY 11235-0003 (718) 934-4500 sales@minicircuits.com

REV. B  
ECO-012606  
HFCG-1500+  
EDU3653  
URJ  
220331  
Page 2 of 3

## Pad Connections

INPUT	1
OUTPUT	3
GROUND	2, 4, 5, 6

Product Marking: LZ

Demo Board MCL P/N: TB-1104+  
Suggested PCB Layout (PL-633)

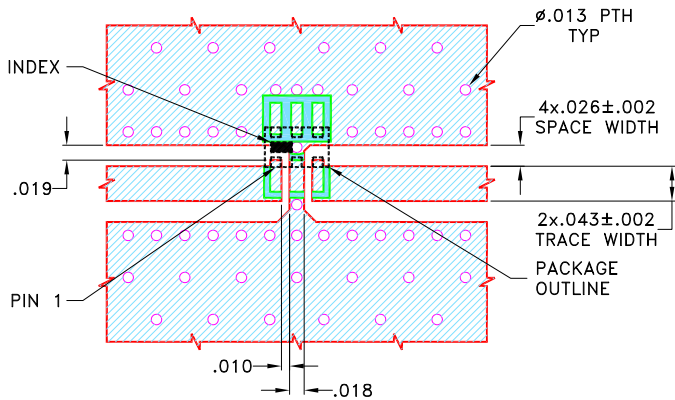

### NOTES:

- COPLANAR WAVEGUIDE PARAMETERS ARE SHOWN FOR ROGERS (R04350B) WITH DIELECTRIC THICKNESS  $.020 \pm .0015$ . COPPER: 1/2 Oz. EACH SIDE. FOR OTHER MATERIALS TRACE WIDTH AND GAP MAY NEED TO BE MODIFIED.
  - BOTTOM SIDE OF THE PCB IS CONTINUOUS GROUND PLANE.
- DENOTES PCB COPPER PATTERN WITH SMOBC (SOLDER MASK OVER BARE COPPER)  
▨ DENOTES PCB COPPER PATTERN FREE OF SOLDERMASK

## Outline Drawing

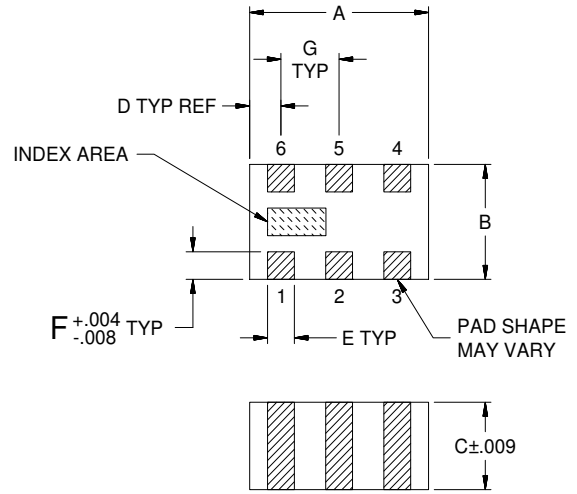

### Outline Dimensions (inch / mm)

A	B	C	D	E	F	G	Wt.
.079	.049	.037	.014	.012	.012	.026	grams
2.00	1.25	0.95	0.35	0.30	0.30	0.65	.008

Note: Please refer to case style drawing for details

### Notes

- A. Performance and quality attributes and conditions not expressly stated in this specification document are intended to be excluded and do not form a part of this specification document.
- B. Electrical specifications and performance data contained in this specification document are based on Mini-Circuit's applicable established test performance criteria and measurement instructions.
- C. The parts covered by this specification document are subject to Mini-Circuits standard limited warranty and terms and conditions (collectively, "Standard Terms"); Purchasers of this part are entitled to the rights and benefits contained therein. For a full statement of the Standard Terms and the exclusive rights and remedies thereunder, please visit Mini-Circuits' website at [www.minicircuits.com/MCLStore/terms.jsp](http://www.minicircuits.com/MCLStore/terms.jsp)

## Typical Performance Data

FREQ. (MHz)	INSERTION LOSS			INPUT RETURN LOSS			OUTPUT RETURN LOSS		
	(dB)			(dB)			(dB)		
	@-55°C	@+25°C	@+100°C	@-55°C	@+25°C	@+100°C	@-55°C	@+25°C	@+100°C
10	70.75	72.17	87.29	0.10	0.14	0.16	0.10	0.15	0.17
20	69.02	68.50	68.29	0.09	0.14	0.15	0.09	0.14	0.15
80	56.67	56.55	56.83	0.09	0.16	0.17	0.12	0.18	0.20
100	54.91	55.00	54.59	0.10	0.17	0.18	0.13	0.19	0.21
200	48.94	49.09	49.10	0.14	0.21	0.23	0.16	0.23	0.25
300	45.70	45.80	45.91	0.17	0.24	0.27	0.19	0.26	0.29
400	43.56	43.60	43.61	0.18	0.27	0.30	0.20	0.29	0.33
500	41.84	41.91	41.91	0.19	0.30	0.34	0.21	0.32	0.36
600	40.42	40.49	40.44	0.20	0.32	0.37	0.22	0.35	0.40
700	39.09	39.17	39.11	0.22	0.36	0.41	0.24	0.39	0.45
800	37.84	37.90	37.86	0.25	0.41	0.48	0.29	0.45	0.53
900	37.03	37.15	37.18	0.31	0.50	0.59	0.34	0.53	0.63
1000	38.23	38.85	39.27	0.42	0.64	0.77	0.44	0.67	0.80
1100	40.37	36.59	33.93	0.63	0.93	1.14	0.64	0.94	1.15
1130	33.36	30.43	28.34	0.74	1.07	1.33	0.73	1.08	1.32
1150	29.40	26.88	25.04	0.83	1.20	1.50	0.82	1.21	1.48
1190	22.72	20.69	19.18	1.11	1.59	2.00	1.06	1.54	1.92
1400	3.00	3.07	3.13	12.47	14.17	15.25	10.66	12.30	13.44
1450	2.10	2.32	2.46	16.75	16.71	16.60	14.76	15.50	15.89
1500	1.67	1.93	2.09	17.33	16.29	15.68	16.96	16.54	16.18
1560	1.39	1.67	1.83	16.03	14.93	14.35	16.97	15.83	15.24
1600	1.27	1.55	1.71	15.05	14.10	13.63	16.00	14.94	14.40
1700	1.07	1.34	1.47	13.53	13.03	12.85	14.22	13.64	13.44
1800	0.91	1.15	1.26	13.29	13.14	13.18	13.78	13.59	13.64
1900	0.75	0.97	1.07	14.14	14.34	14.50	14.57	14.73	14.90
2000	0.60	0.81	0.91	16.01	16.56	16.80	16.29	16.80	17.02
2100	0.47	0.68	0.78	19.22	20.09	20.48	19.51	20.35	20.69
2200	0.38	0.59	0.68	24.12	25.32	26.08	23.81	24.93	25.54
2300	0.32	0.54	0.63	30.14	30.11	30.00	28.04	28.16	28.29
2400	0.30	0.51	0.60	25.35	24.21	23.78	24.07	23.35	23.15
2500	0.28	0.50	0.59	21.53	20.75	20.45	20.85	20.32	20.18
2600	0.28	0.50	0.59	18.60	18.19	17.95	18.22	17.96	17.87
2700	0.28	0.51	0.60	16.98	16.77	16.60	16.79	16.70	16.65
2800	0.28	0.51	0.60	15.89	15.74	15.65	15.78	15.77	15.74
2900	0.27	0.51	0.60	15.28	15.20	15.13	15.22	15.27	15.29
3000	0.26	0.50	0.59	14.94	14.95	14.90	14.90	15.03	15.05
3100	0.26	0.49	0.59	14.89	14.94	14.89	14.94	15.12	15.15
3200	0.23	0.47	0.56	15.06	15.09	15.11	15.14	15.32	15.39
3300	0.20	0.45	0.54	15.40	15.45	15.44	15.49	15.72	15.79
3400	0.17	0.42	0.52	16.01	16.03	15.98	16.12	16.37	16.36
3500	0.15	0.40	0.50	16.69	16.75	16.64	16.78	17.07	17.02
3600	0.12	0.37	0.48	17.68	17.82	17.62	17.90	18.29	18.12
3700	0.09	0.34	0.45	18.76	19.00	18.76	19.09	19.58	19.42
3800	0.06	0.32	0.42	20.19	20.41	20.19	20.92	21.47	21.31
3900	0.04	0.30	0.41	22.10	22.28	22.07	23.26	23.95	23.85
4000	0.03	0.29	0.40	24.75	24.89	24.56	26.94	27.92	27.72
4100	0.01	0.28	0.39	27.41	27.31	27.29	31.44	33.17	33.00
4200	0.02	0.28	0.39	27.85	27.67	28.14	32.43	33.37	34.57
4300	0.01	0.28	0.39	24.78	24.84	25.32	26.82	27.17	27.46
4400	0.01	0.28	0.40	22.54	22.52	22.82	23.43	23.51	23.61
4500	0.02	0.30	0.41	20.18	20.08	20.35	20.69	20.71	20.79
4600	0.05	0.33	0.44	18.03	17.90	18.20	18.36	18.29	18.49
5000	0.17	0.47	0.58	12.97	13.16	13.39	13.14	13.40	13.57
5200	0.24	0.54	0.66	11.39	11.60	11.84	11.58	11.85	12.06
5300	0.29	0.60	0.72	10.69	10.94	11.16	10.85	11.14	11.36
5400	0.34	0.65	0.78	10.04	10.35	10.56	10.25	10.56	10.80
5500	0.39	0.70	0.83	9.52	9.86	10.05	9.73	10.08	10.29
5600	0.44	0.76	0.88	9.07	9.40	9.64	9.34	9.68	9.96
5800	0.51	0.84	0.97	8.57	8.83	9.09	8.68	8.98	9.28
6000	0.59	0.94	1.08	7.97	8.23	8.55	8.05	8.34	8.66

## Typical Performance Data

FREQ.  (MHz)	GROUP DELAY		
	(nsec)		
	@-55°C	@+25°C	@+100°C
1600	0.85	0.81	0.78
1640	0.76	0.73	0.70
1680	0.69	0.66	0.64
1700	0.65	0.62	0.60
1760	0.59	0.57	0.55
1800	0.55	0.53	0.52
1840	0.52	0.50	0.49
1880	0.48	0.47	0.46
2000	0.41	0.40	0.39
2100	0.36	0.36	0.35
2200	0.33	0.32	0.31
2300	0.29	0.29	0.28
2400	0.26	0.26	0.25
2500	0.24	0.23	0.23
2600	0.22	0.21	0.21
2700	0.20	0.19	0.19
2800	0.18	0.18	0.17
2900	0.17	0.16	0.16
3000	0.16	0.15	0.15
3100	0.15	0.14	0.14
3200	0.14	0.14	0.13
3300	0.13	0.13	0.13
3400	0.13	0.12	0.12
3500	0.12	0.12	0.11
3600	0.12	0.11	0.11
3700	0.11	0.11	0.11
3800	0.11	0.11	0.10
3900	0.11	0.10	0.10
4000	0.10	0.10	0.10
4100	0.10	0.10	0.10
4200	0.10	0.10	0.09
4300	0.10	0.09	0.09
4400	0.09	0.09	0.09
4500	0.09	0.09	0.08
4600	0.09	0.08	0.08
4700	0.08	0.08	0.08
4800	0.08	0.08	0.08
4900	0.08	0.08	0.07
5000	0.08	0.08	0.07
5500	0.06	0.06	0.06
6000	0.06	0.06	0.05

## Typical Performance Curves

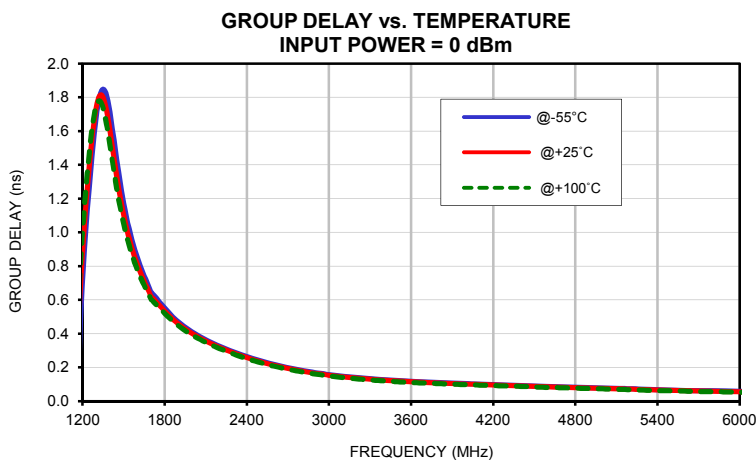
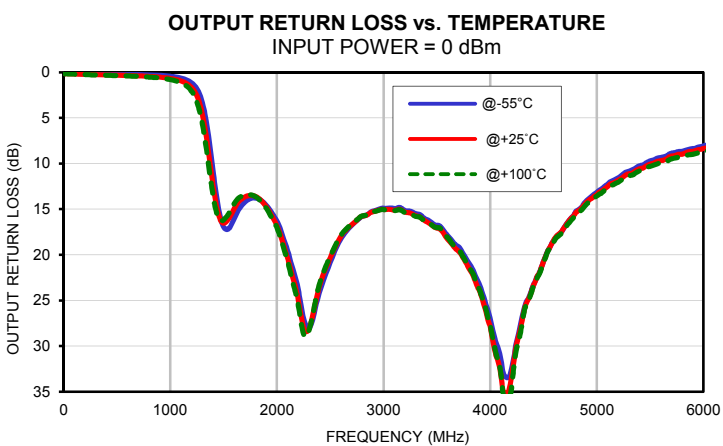
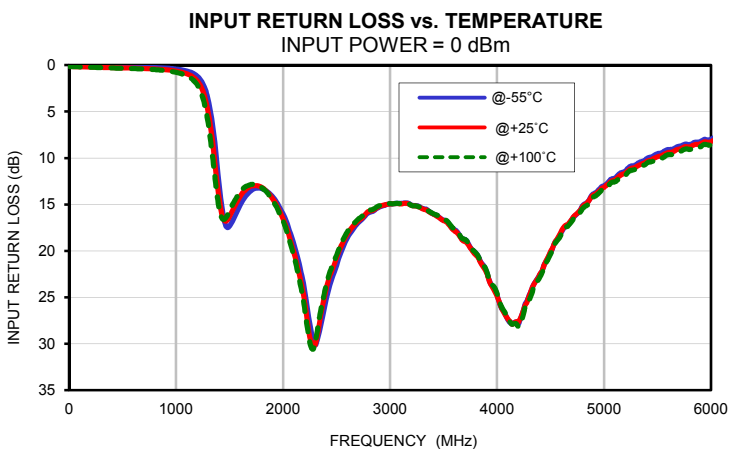
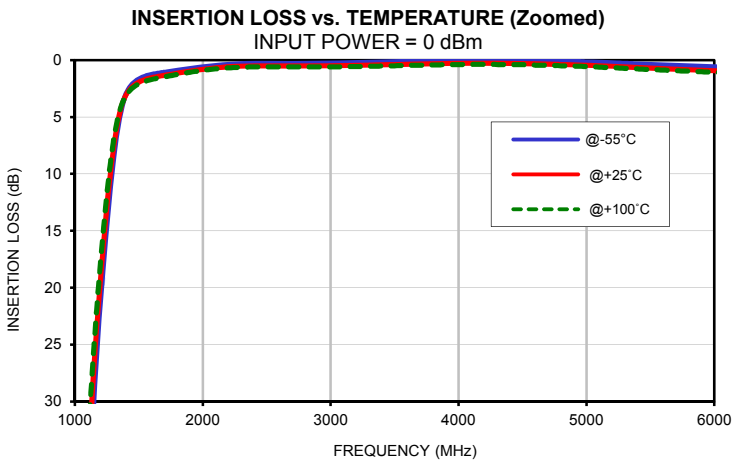
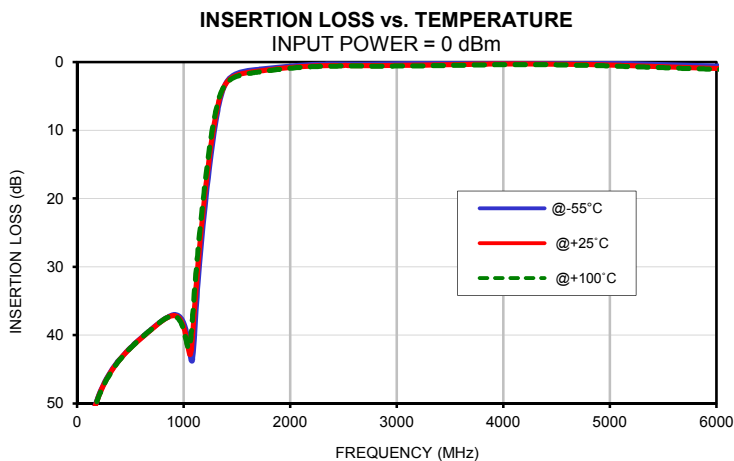

### Outline Dimensions

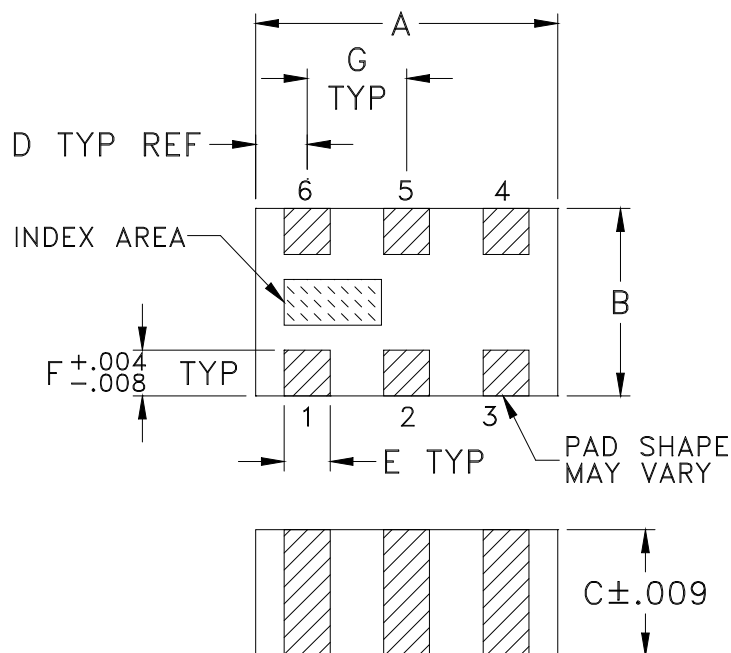

### PCB Land Pattern

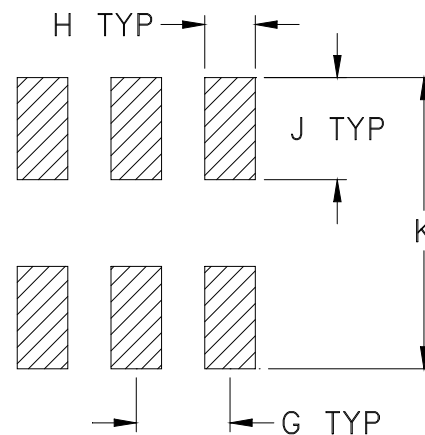

Suggested Layout,  
Tolerance to be within  $\pm .002$

CASE #	A	B	C	D	E	F	G	H	J	K	WT.GRAM
GE0805C-9	.079 (2.00)	.049 (1.25)	.037 (0.95)	.014 (0.35)	.012 (0.30)	.012 (0.30)	.026 (0.65)	.014 (0.35)	.039 (1.00)	.110 (2.80)	.008

Dimensions are in inches (mm). Tolerances: 2Pl.  $\pm .01$ ; 3 Pl.  $\pm .005$

#### Notes:

- Open style, ceramic base.
- Termination finish: For RoHS Case Styles: Tin plate over Nickel plate. All models, (+) suffix.  
For RoHS-5 Case Styles: Tin-Lead plate over Nickel plate. All models, no (+) suffix.



P.O. Box 350166, Brooklyn, New York 11235-0003 (718) 934-4500 Fax (718) 332-4661 For detailed performance specs & shopping online see Mini-Circuits web site



Provides ACTUAL Data Instantly From MINI-CIRCUITS At: [www.minicircuits.com](http://www.minicircuits.com)

RF/IF MICROWAVE COMPONENTS

# Tape & Reel Packaging TR-F114

## DEVICE ORIENTATION IN T&R

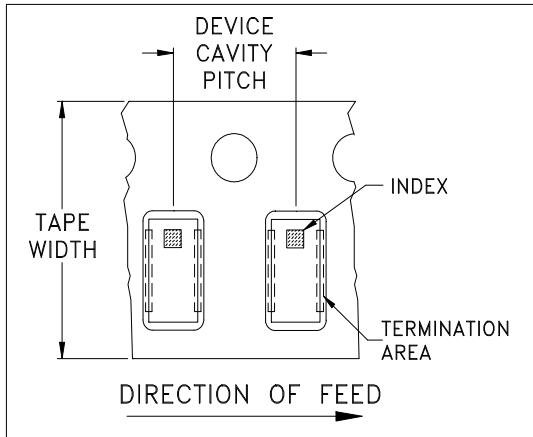

ILLUSTRATION 1

Applicable Case Styles	
GE0805C	JC0603C
GE0805C-1	JC0603C-4
GE0805C-1AP	JC0603C-6
GE0805C-7	
GE0805C-9	
GE0805C-10	
GE0805C-11	
GE0805C-12	

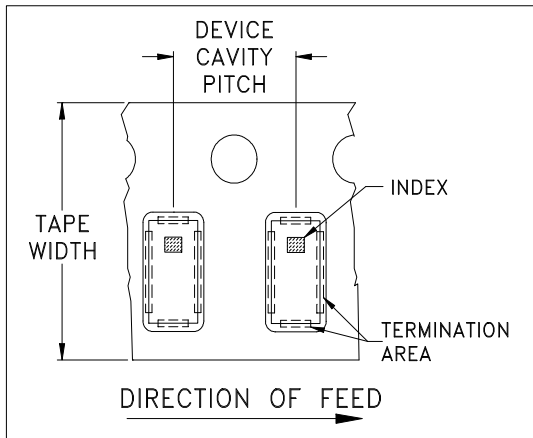

ILLUSTRATION 2

Applicable Case Styles	
GE0805C-2	JC0603C-1
GE0805C-3	JC0603C-2
GE0805C-4	JC0603C-3
GE0805C-5	JC0603C-5
GE0805C-6	JC0603C-7
GE0805C-8	JV1210C-1
GE0805C-15	

Tape Width, mm	Device Cavity Pitch, mm	Reel Size, inches	Devices per Reel	
8	4	7	Small quantity standards (see note)	20
				50
				100
				200
				500
				1000
			Standard	4000

Note: Please Consult individual model data sheet to determine device per reel availability.

Mini-Circuits carrier tape materials provide protection from ESD (Electro-Static Discharge) during handling and transportation. Tapes are static dissipative and comply with industry standards EIA-481/EIA-541.

Go to: [www.minicircuits.com/pages/pdfs/tape.pdf](http://www.minicircuits.com/pages/pdfs/tape.pdf)



INTERNET <http://www.minicircuits.com>

P.O. Box 350166, Brooklyn, New York 11235-0003 (718) 934-4500 Fax (718) 332-4661

Distribution Centers NORTH AMERICA 800-654-7949 • 417-335-5935 • Fax 417-335-5945 • EUROPE 44-1252-832600 • Fax 44-1252-837010

Mini-Circuits ISO 9001 & ISO 14001 Certified



THIRD ANGLE PROJECTION

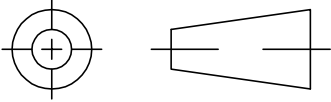

REVISIONS

REV OR	ECN No.	DESCRIPTION	DATE	DR	AUTH
	M174039	NEW RELEASE	MAY 19	DDR	VC

SUGGESTED MOUNTING CONFIGURATION FOR  
GE0805C-9 CASE STYLE "06FL02" PIN CODE

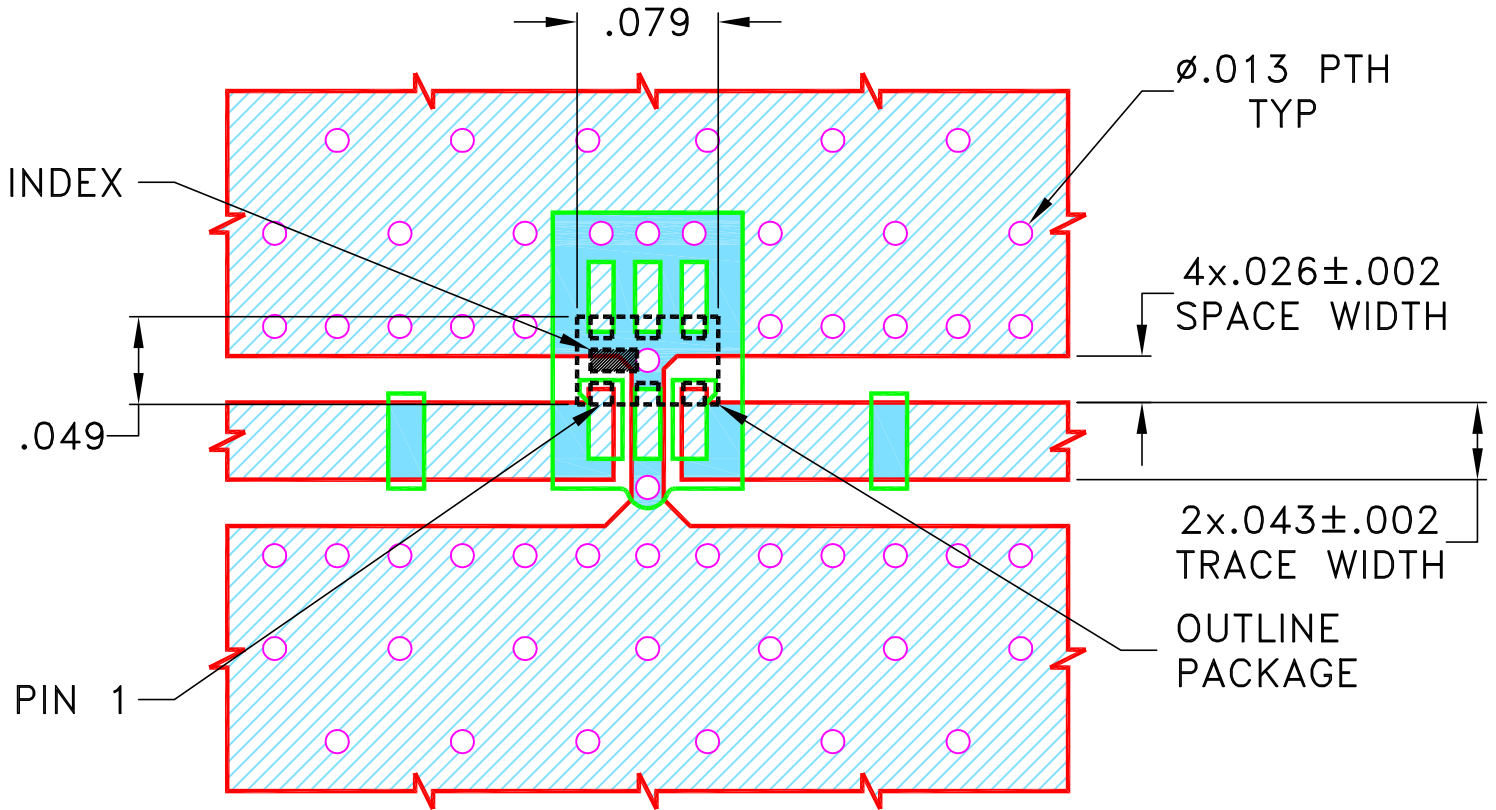

NOTES:

- TRACE WIDTH IS SHOWN FOR ROGERS (R04350B) WITH DIELECTRIC THICKNESS  $.020" \pm .0015"$ . COPPER: 1/2 Oz. EACH SIDE.  
FOR OTHER MATERIALS TRACE WIDTH MAY NEED TO BE MODIFIED.
- BOTTOM SIDE OF THE PCB IS CONTINUOUS GROUND PLANE.



DENOTES PCB COPPER LAYOUT WITH SMOBC  
(SOLDER MASK OVER BARE COPPER)



DENOTES COPPER LAND PATTERN FREE OF SOLDERMASK

UNLESS OTHERWISE SPECIFIED	INITIALS	DATE
DIMENSIONS ARE IN INCHES	DRAWN: DDR	08 MAY 19
TOLERANCES ON:	CHECKED: RV	08 MAY 19
2 PL DECIMALS $\pm$	APPROVED: RKS	08 MAY 19
3 PL DECIMALS $\pm$ .005"		
ANGLES $\pm$		
FRACTIONS $\pm$		



**Mini-Circuits®** 13 Neptune Avenue  
Brooklyn NY 11235

PL, 06FL02, GE0805C-9  
TB-1104+, 50 OHM

Mini-Circuits®  
THIS DOCUMENT AND ITS CONTENTS ARE THE PROPERTY OF MINI-CIRCUITS. EXCEPT FOR USE EXPRESSLY GRANTED, IN WRITING, TO ITS VENDORS, VENDEE AND THE UNITED STATES GOVERNMENT, MINI-CIRCUITS RESERVES ALL PROPRIETARY DESIGN, USE, MANUFACTURING AND REPRODUCTION RIGHTS THERETO. THESE CONTENTS SHALL NOT BE USED, DUPLICATED OR DISCLOSED TO ANY OUTSIDE PARTY, IN WHOLE OR IN PART, WITHOUT WRITTEN PERMISSION OF MINI-CIRCUITS.

ASHEETA1.DWG REV:A DATE:01/12/95

SIZE: A	CODE IDENT: 15542	DRAWING NO: 98-PL-633	REV: OR
FILE: 98PL633	SCALE: 9:1	SHEET: 1 OF 1	

# Evaluation Board and Circuit

TB-1104+

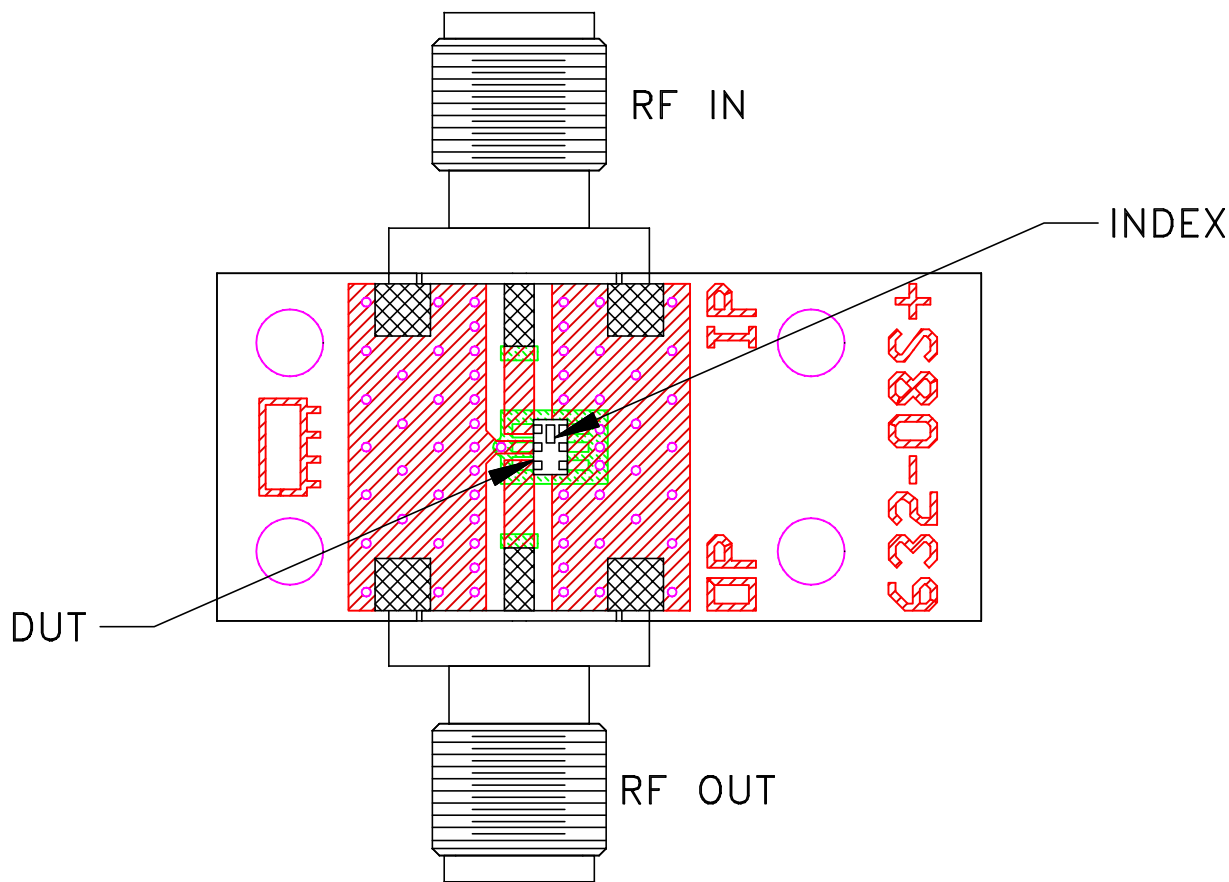

Schematic diagram

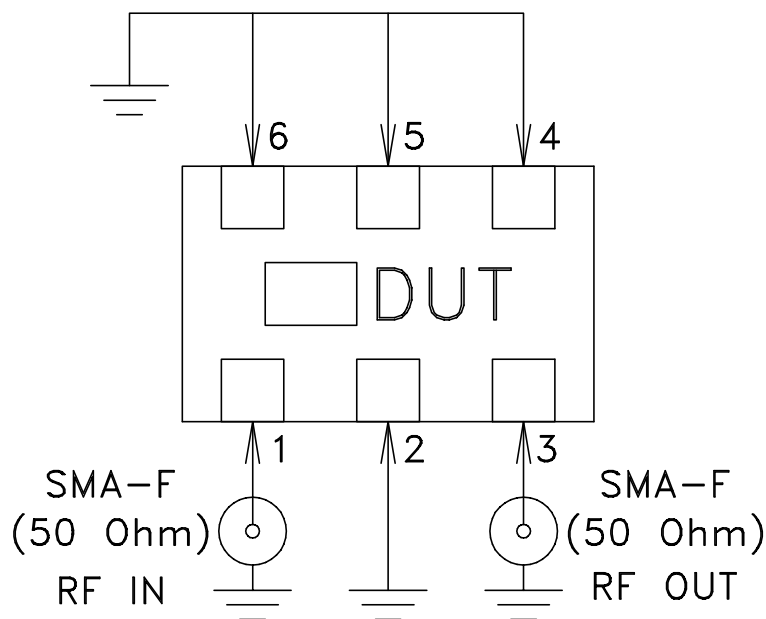

Notes:

1. 50 Ohm SMA Female connectors.
2. PCB Material: ROGERS (RO4350B), OR Equivalent  
Dielectric Constant=3.48, Thickness=.020inch.

 **Mini-Circuits®**

All Mini-Circuits products are manufactured under exacting quality assurance and control standards, and are capable of meeting published specifications after being subjected to any or all of the following physical and environmental test.

Specification	Test/Inspection Condition	Reference/Spec
Operating Temperature	-55° to 100°C Ambient Environment	Individual Model Data Sheet
Storage Temperature	-55° to 100° C Ambient Environment	Individual Model Data Sheet
Humidity	90 to 95% RH, 240 hours, 50°C	MIL-STD-202, Method 103, Condition A, Except 50°C and end-point electrical test done within 12 hours
Solder Reflow Heat	Sn-Pb Eutetic Process: 225°C peak Pb-Free Process 245° - 250°C peak	J-STD-020, Table 4-1, 4-2 and 5-2, Figure 5-1
Solderability	10X Magnification	J-STD-002, Para 4.2.5, Test S, 95% Coverage
Vibration (High Frequency)	20g peak, 10-2000 Hz, 12 times in each of three perpendicular directions (total 36)	MIL-STD-202, Method 204, Condition D
Mechanical Shock	50g, 11 ms, 1/2-sine, 18 shocks: 3 each direction, each of 3 axes	MIL-STD-202, Method 213, Condition A