



COAXIAL

# Fixed Attenuator

HAT-A-SERIES

Mini-Circuits

50Ω

Up to 2W

DC to 2000 MHz

## THE BIG DEAL

- Wideband coverage, DC to 2000 MHz
- Up to 2 Watt rating
- Rugged unibody construction
- Excellent VSWR
- Excellent flatness

## APPLICATIONS

- Signal level adjustment
- Impedance matching



Generic photo used for illustration purposes only

Model No.	HAT-A-SERIES
Case Style	FF747
Connectors	BNC Male-BNC Female

### +RoHS Compliant

The +Suffix identifies RoHS Compliance. See our web site for RoHS Compliance methodologies and qualifications

## PRODUCT OVERVIEW

Mini-Circuits' HAT-A series are fixed attenuators from DC to 2000 MHz frequency range with excellent flatness in attenuation. HAT-A series is available with nominal attenuation of 1 to 30 dB. This attenuator series support testing and measurement application. Precise performance, excellent VSWR and rugged unibody construction makes this model ideal solution for systems requiring precise attenuation across very wide frequency range.

## KEY FEATURES

Feature	Advantages
Rugged construction	Excellent durability for a long lifetime of use
Up to 2 Watt rating	Good power handling
Excellent VSWR	Well matched for 50 Ω systems
Flat attenuation	Good performance over the band.

Mini-Circuits



COAXIAL

# Fixed Attenuator

HAT-30A+

## MAXIMUM RATINGS

Operating Temperature	-45°C to 100°C
Storage Temperature	-55°C to 100°C

Permanent damage may occur if any of these limits are exceeded.

## OUTLINE DRAWING

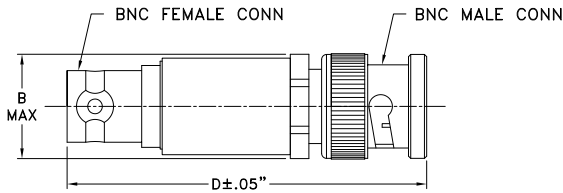

## OUTLINE DIMENSIONS (Inch/mm)

B	D	wt
.62	1.94	grams
15.75	49.28	30.0

Note: Please refer to case style drawing for details

## ELECTRICAL SCHEMATIC

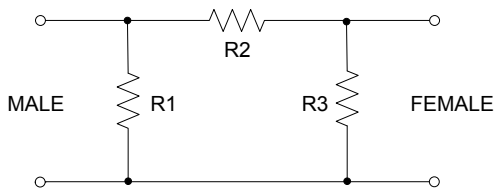

## ELECTRICAL SPECIFICATIONS AT 25°C

Parameter	Condition (MHz)	Min.	Typ.	Max.	Unit
Frequency Range		DC	-	2000	MHz
Attenuation <sup>1</sup> nominal <sup>3</sup>	10	-	30 ± 0.3	-	dB
Attenuation Flatness <sup>2</sup>	DC - 500	-	0.20	-	dB
	DC - 1000	-	0.30	-	
	DC - 2000	-	0.60	-	
VSWR	DC - 500	-	1.30	-	:1
	DC - 1000	-	1.30	-	
	DC - 2000	-	1.40	-	
Input Power <sup>4</sup>		-	-	1.0	W

1. Attenuation varies by 0.3 dB max. over temperature.
2. Flatness = variation over band divided by 2.
3. Nominal attenuation at 10 MHz
4. RF power at 25°C is 1.0W; Derate linearly to 0.8W at 85°C

## TYPICAL PERFORMANCE DATA

Frequency (MHz)	Attenuation (dB)	VSWR (:1)
10	29.92	1.22
50	29.95	1.22
100	29.96	1.22
250	30.00	1.22
400	30.02	1.23
500	30.04	1.24
600	30.06	1.24
800	30.11	1.25
1000	30.16	1.26
1200	30.22	1.26
1300	30.25	1.26
1500	30.32	1.24
1700	30.38	1.22
1800	30.42	1.21
2000	30.50	1.19

HAT-30A+ ATTENUATION

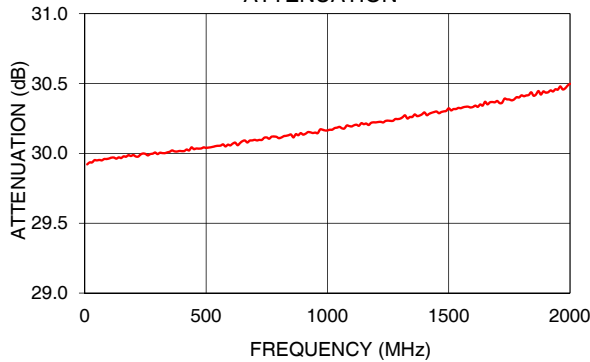

HAT-30A+ VSWR

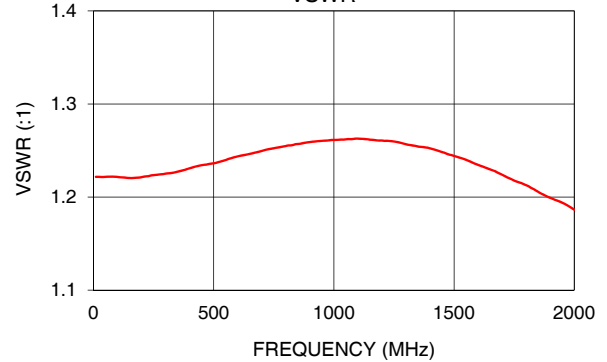

### NOTES

- Performance and quality attributes and conditions not expressly stated in this specification document are intended to be excluded and do not form a part of this specification document.
- Electrical specifications and performance data contained in this specification document are based on Mini-Circuit's applicable established test performance criteria and measurement instructions.
- The parts covered by this specification document are subject to Mini-Circuits standard limited warranty and terms and conditions (collectively, "Standard Terms"); Purchasers of this part are entitled to the rights and benefits contained therein. For a full statement of the standard. Terms and the exclusive rights and remedies thereunder, please visit Mini-Circuits' website at [www.minicircuits.com/MCLStore/terms.jsp](http://www.minicircuits.com/MCLStore/terms.jsp)



*Typical Performance Data*

FREQ.	ATTENUATION	VSWR
(MHz)	(dB)	(:1)
10	29.92	1.22
20	29.94	1.22
50	29.95	1.22
80	29.96	1.22
100	29.96	1.22
120	29.97	1.22
150	29.97	1.22
180	29.99	1.22
210	29.98	1.22
240	30.00	1.22
270	30.00	1.22
300	30.00	1.23
330	30.00	1.23
360	30.02	1.23
390	30.02	1.23
420	30.03	1.23
450	30.03	1.23
480	30.04	1.24
500	30.04	1.24
530	30.05	1.24
560	30.06	1.24
590	30.06	1.24
620	30.08	1.24
650	30.09	1.25
680	30.09	1.25
710	30.09	1.25
750	30.11	1.25
780	30.12	1.25
810	30.11	1.26
840	30.13	1.26
890	30.14	1.26
920	30.15	1.26
950	30.15	1.26
980	30.17	1.26
1000	30.16	1.26
1030	30.18	1.26
1050	30.19	1.26
1080	30.20	1.26
1110	30.20	1.26
1150	30.21	1.26
1180	30.22	1.26
1200	30.22	1.26
1230	30.22	1.26
1250	30.23	1.26
1280	30.25	1.26
1300	30.25	1.26
1350	30.26	1.25
1400	30.29	1.25
1450	30.30	1.25
1500	30.32	1.24
1550	30.32	1.24
1600	30.33	1.23
1650	30.37	1.23
1700	30.38	1.22
1750	30.39	1.22
1800	30.42	1.21
1850	30.41	1.21
1900	30.44	1.20
1950	30.46	1.19
2000	30.50	1.19

## Typical Performance Curves

### ATTENUATION

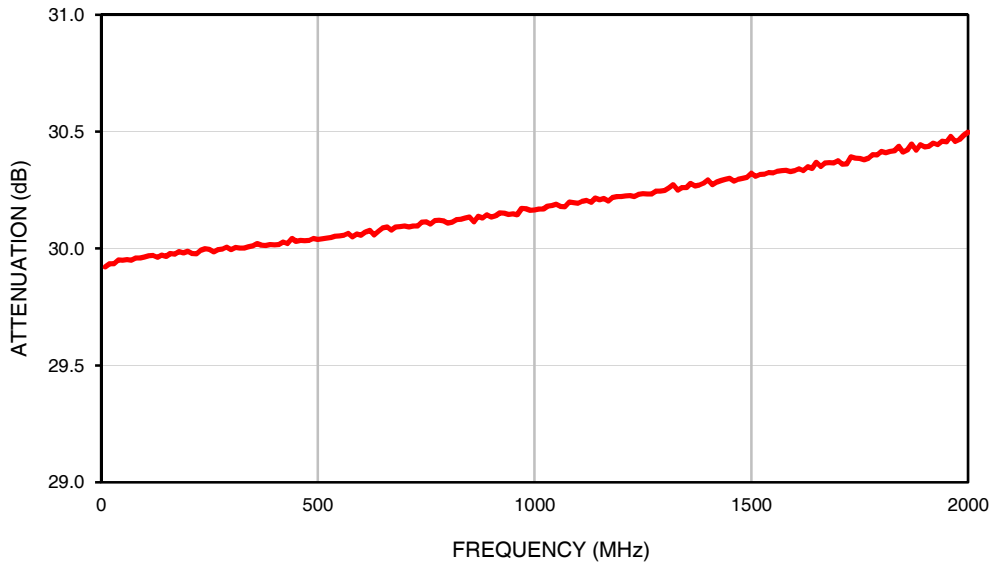

### VSWR

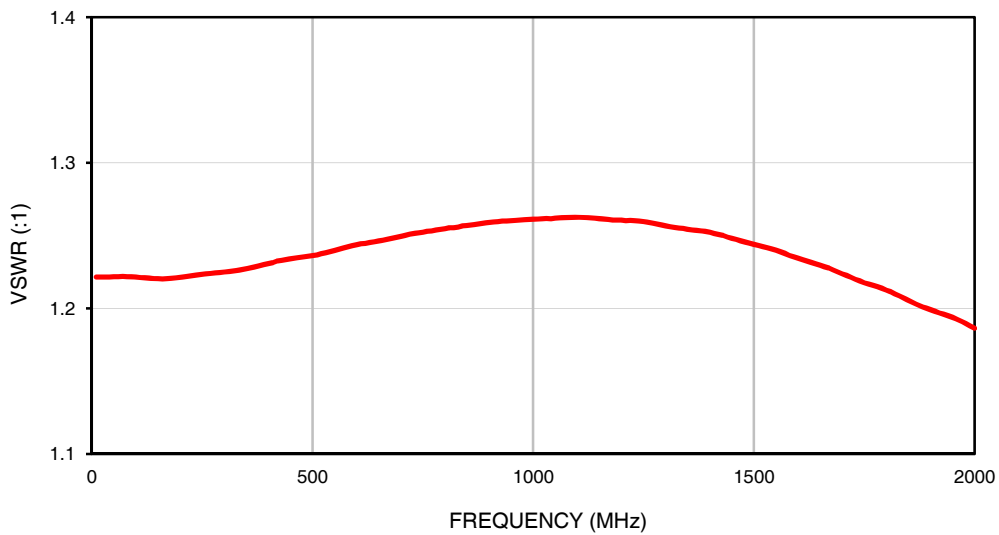

# Case Style

# FF

## Outline Dimensions

### FF747

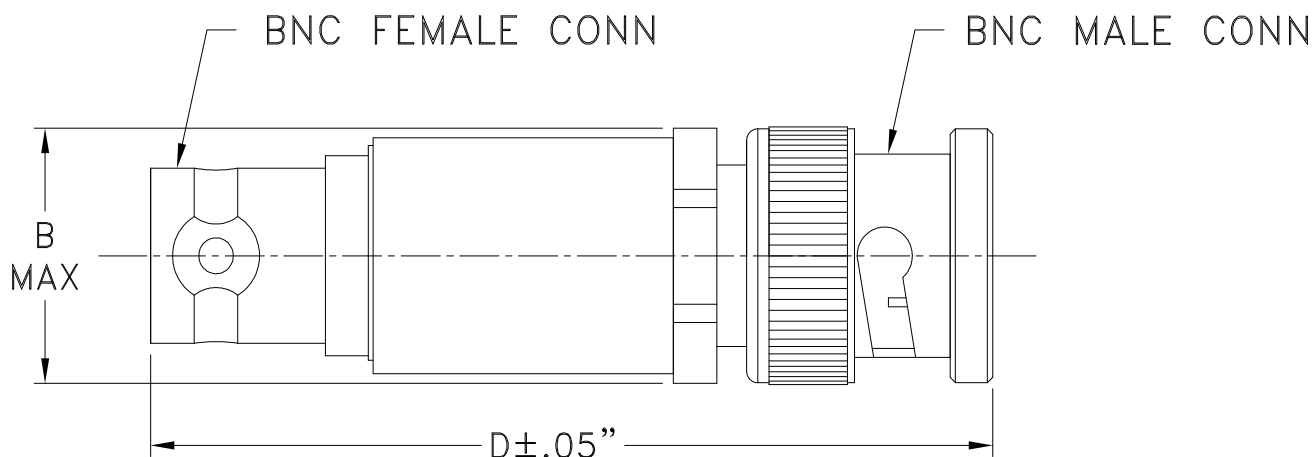

CASE #.	A	B	C	D	E	WT GRAMS
FF747	--	.62 (15.75)	--	1.94 (49.28)	--	30.0

Dimensions are in inches (mm). Tolerances: 2Pl. ± .04; 3Pl. ± .030

### Notes:

1. Case material: Brass.
2. Case finish: Nickel plate.



P.O. Box 350166, Brooklyn, New York 11235-0003 (718) 934-4500 Fax (718) 332-4661 For detailed performance specs & shopping online see Mini-Circuits web site



The Design Engineers Search Engine Provides ACTUAL Data Instantly From MINI-CIRCUITS At: [www.minicircuits.com](http://www.minicircuits.com)

RF/IF MICROWAVE COMPONENTS



All Mini-Circuits products are manufactured under exacting quality assurance and control standards, and are capable of meeting published specifications after being subjected to any or all of the following physical and environmental test.

Specification	Test/Inspection Condition	Reference/Spec
Operating Temperature	-45° to 100° C Ambient Environment	Individual Model Data Sheet
Storage Temperature	-55° to 100° C Ambient Environment	Individual Model Data Sheet
Barometric Pressure	100,000 Feet	MIL-STD-202, Method 105, Condition D
Humidity	90% RH, 65°C Units may require bake-out after humidity to restore full performance.	MIL-STD-202, Method 103
Thermal Shock	-65° to 125°C, 5 cycles	MIL-STD-202, Method 107, Condition B
Vibration (High Frequency)	20g peak, 10-2000 Hz, 12 times in each of three perpendicular directions (total 36)	MIL-STD-202, Method 204, Condition D
Mechanical Shock	100g, 6ms sawtooth, 3 shocks each direction 3 axes (total 18)	MIL-STD-202, Method 213, Condition I