



FLAT GAIN, ULTRA-WIDEBAND

Monolithic Amplifier

GVA-93+

50Ω 0.01 to 9 GHz

THE BIG DEAL

- Ultra broadband performance
- Excellent Gain Flatness, ± 0.7 dB, 0.05-8 GHz
- Broadband without external matching components
- Suitable for low phase noise applications
- Excellent return loss, 20 dB typ., 2 GHz

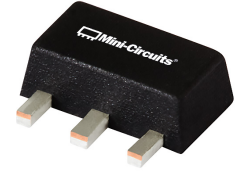

Generic photo used for illustration purposes only

CASE STYLE: DF782

+RoHS Compliant

The +Suffix identifies RoHS Compliance. See our web site for RoHS Compliance methodologies and qualifications

APPLICATIONS

- Base station infrastructure
- Test instruments
- MMDS & Wireless LAN
- LTE
- Satellite communication
- Avionics

PRODUCT OVERVIEW

GVA-93+ (RoHS compliant) is an advanced ultra-wideband amplifier fabricated using GaAs HBT technology and offers excellent gain flatness over a broad frequency range. In addition, the GVA-93+ has good input and output return loss over this frequency range without the need for external matching components. It has repeatable performance from lot to lot and is enclosed in a SOT-89 package for very good thermal performance.

KEY FEATURES

Feature	Advantages
Ultra Broad Band: 0.01 to 9 GHz	Broadband covering primary wireless communications bands: Cellular, PCS, LTE, WiMAX in a single amplifier.
Ultra Flat Gain ± 0.7 dB typ: 0.05 - 8 GHz	Ultra Flat Gain, eliminates need for compensation networks to achieve published results
No External Matching Components Required	GVA-93+ provides good Input and Output Return Loss of 12-28 dB over 0.05 - 6 GHz without the need for any external matching components
Excellent ESD HBM: class 1C (1000 to <2000V) MM: class M2 (100 to <200V)	Simplifies ESD handling.
Low additive phase noise, typically -169 dBc/Hz @10 KHz offset	Ideal for low phase noise synthesizer applications

REV. B
ECO-010563
GVA-93+
TH/RS/CP
111121





ELECTRICAL SPECIFICATIONS AT 25°C AND VCC=5V, R= 16.5Ω UNLESS NOTED

Parameter	Condition (GHz)	Min.	Typ.	Max.	Units
Frequency Range		0.01		9.0	GHz
Gain	0.05	—	16.2	—	dB
	0.85	—	17.2	—	
	2.0	15.2	16.9	18.6	
	6.0	—	16.4	—	
	8.0	—	16.3	—	
	9.0	—	15.2	—	
Gain Flatness	0.05-8		±0.7		dB
Input Return Loss	0.05	—	12.7	—	dB
	0.85	—	24.9	—	
	2.0	16.0	23.8	—	
	6.0	—	22.2	—	
	8.0	—	9.2	—	
	9.0	—	7.1	—	
Output Return Loss	0.05		14.4		dB
	0.85		31.0		
	2.0		23.5		
	6.0		15.5		
	8.0		9.2		
	9.0		7.0		
Reverse Isolation	6.0		20.7		dB
Output Power at 1dB Compression	0.05		15.9		dBm
	0.85		16.3		
	2.0		16.2		
	6.0		13.4		
	8.0		10.3		
	9.0		9.0		
Output IP3	0.2		30.2		dBm
	0.85		31.1		
	2.0		29.9		
	6.0		24.5		
	8.0		21.8		
	9.0		20.3		
Noise Figure	0.2		3.8		dB
	0.85		3.9		
	2.0		4.0		
	6.0		4.4		
	8.0		4.9		
	9.0		5.3		
Additive Phase Noise 2 GHz, 10 KHz offset			-169		dBc/Hz
Supply Operating Voltage (Vcc)		4.8	5.0	5.2	V
Device Operating Current			52	57	mA
Device Current Variation vs. Temperature ²			56		μA/°C
Device Current Variation vs. Voltage			0.020		mA/mW
Thermal Resistance, junction-to-ground lead			156		°C/W

(1) Measured on Mini-Circuits Characterization test board TB-665+. See Characterization Test Circuit (Fig. 1)

(2) (Current at 85°C – Current at -45°C)/130



ABSOLUTE MAXIMUM RATINGS⁽³⁾

Parameter	Ratings
Operating Temperature (ground lead)	-40°C to 85°C
Storage Temperature	-65°C to 150°C
Operating Current at 5V (Vcc) & 16.5Ω resistor	100 mA
Power Dissipation	0.34 W
Input Power (CW)	28 dBm (5 min max.) 11 dBm (continuous)
DC Voltage on Pin 3	6 V

(3) Permanent damage may occur if any of these limits are exceeded.
Electrical maximum ratings are not intended for continuous normal operation.

SIMPLIFIED SCHEMATIC AND PIN DESCRIPTION

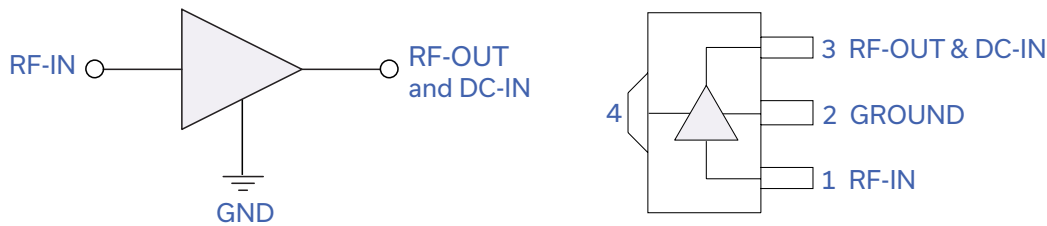

Function	Pin Number	Description
RF IN	1	RF input pin. This pin requires the use of an external DC blocking capacitor chosen for the frequency of operation.
RF-OUT and DC-IN	3	RF output and bias pin. DC voltage is present on this pin; therefore a DC blocking capacitor is necessary for proper operation. An RF choke is needed to feed DC bias without loss of RF signal due to the bias connection, as shown in "Recommended Application Circuit", Fig. 2
GND	2,4	Connections to ground. Use via holes as shown in "Suggested Layout for PCB Design" to reduce ground path inductance for best performance.



CHARACTERIZATION TEST CIRCUIT

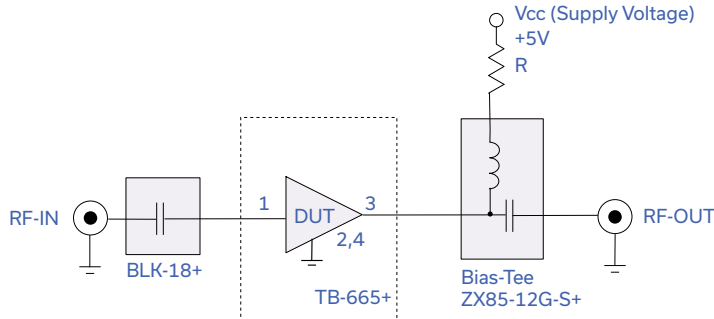

Fig 1. Block Diagram of Test Circuit used for characterization. (DUT soldered on Mini-Circuits Characterization test board TB-665+) Gain, Return loss, Output power at 1dB compression (P1 dB) , output IP3 (OIP3) and noise figure measured using Agilent's N5242A PNA-X microwave network analyzer. (R=16.5Ω)

Conditions:

1. Gain and Return loss: Pin= -25dBm
2. Output IP3 (OIP3): Two tones, spaced 1 MHz apart, 0 dBm/tone at output.

RECOMMENDED APPLICATION CIRCUIT

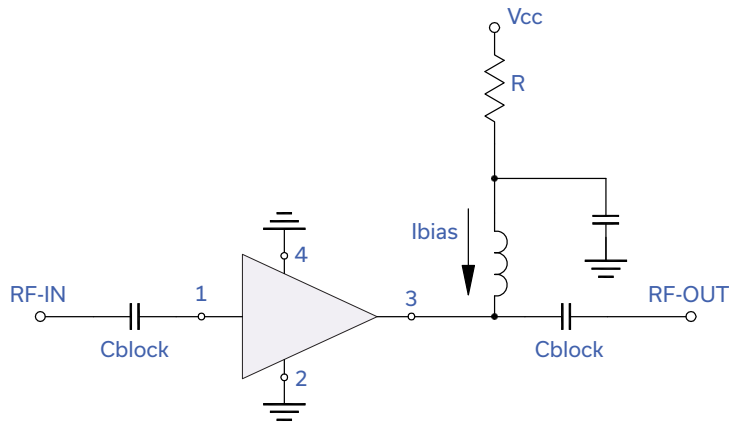
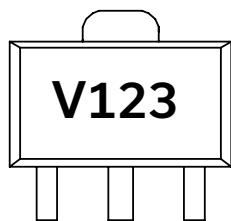

Fig 2. Test Board includes case, connectors, and components soldered to PCB (Cblock=0.001 μF, Cbypass=0.1 μF, R=16.5Ω)

PRODUCT MARKING



Marking may contain other features or characters for internal lot control



ADDITIONAL DETAILED TECHNICAL INFORMATION IS AVAILABLE ON OUR DASH BOARD. TO ACCESS [CLICK HERE](#)

Performance Data	Data Table
	Swept Graphs
	S-Parameter (S2P Files) Data Set (.zip file)
Case Style	DF782 (SOT 89) Plastic package, exposed paddle lead finish: Matte-tin
Tape & Reel Standard quantities available on reel	F55 7" reels with 20, 50, 100, 200, 500 or 1K devices
Suggested Layout for PCB Design	PL-370
Evaluation Board	TB-781-1+
Environmental Ratings	ENV08T1

ESD RATING

Human Body Model (HBM): Class 1C (1000 to <2000V) in accordance with ANSI/ESD STM 5.1 - 2001

MSL RATING

Moisture Sensitivity: MSL1 in accordance with IPC/JEDEC J-STD-020D

MSL TEST FLOW CHART

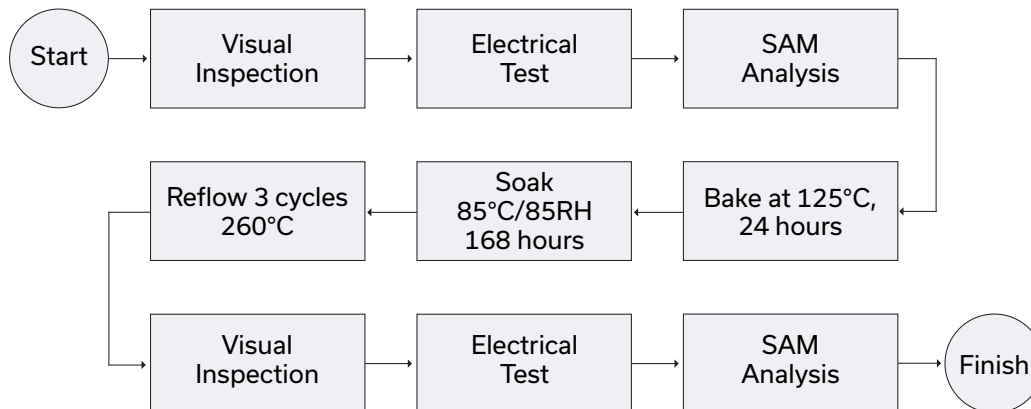

- NOTES**
- A. Performance and quality attributes and conditions not expressly stated in this specification document are intended to be excluded and do not form a part of this specification document.
 - B. Electrical specifications and performance data contained in this specification document are based on Mini-Circuit's applicable established test performance criteria and measurement instructions.
 - C. The parts covered by this specification document are subject to Mini-Circuits standard limited warranty and terms and conditions (collectively, "Standard Terms"); Purchasers of this part are entitled to the rights and benefits contained therein. For a full statement of the standard. Terms and the exclusive rights and remedies thereunder, please visit Mini-Circuits' website at www.minicircuits.com/MCLStore/terms.jsp

Typical Performance Data

NOTE: Use PDF Bookmarks to view DATA at required conditions

Definitions:

Input Return Loss = -S11 (dB)
 Gain(Power Gain) = S21 (dB)
 Reverse Isolation = -S12 (dB)
 Output Return Loss = -S22 (dB)

TEST CONDITIONS: Vd = 5V, Id = 48.08 mA @ Temperature = +25degC

FREQ	Gain	Isolation	Input Return Loss	Output Return Loss	Stability		IP-3 Output	1dB Comp. Output	Noise Figure
					K	Measure			
(MHz)	(dB)	(dB)	(dB)	(dB)	K	Measure	(dBm)	(dBm)	(dB)
10	14.30	23.80	9.90	12.23	1.36	0.97	--	16.00	7.62
20	14.67	22.53	10.49	12.50	1.23	0.89	16.79	16.60	7.65
30	15.22	22.04	11.08	13.02	1.18	0.82	17.69	16.89	6.74
40	15.74	21.51	11.84	13.69	1.14	0.74	18.65	16.89	6.10
50	16.20	21.15	12.66	14.48	1.11	0.67	19.61	16.60	5.69
60	16.51	20.62	13.62	15.35	1.08	0.59	21.50	16.55	5.33
70	16.79	20.49	14.60	16.15	1.07	0.55	23.39	16.52	4.97
80	17.00	20.28	15.60	17.10	1.06	0.51	25.52	16.15	4.68
90	17.15	20.13	16.63	17.97	1.05	0.48	26.97	15.99	4.58
100	17.26	20.04	17.68	18.88	1.05	0.46	28.22	16.00	4.33
200	17.50	19.87	27.36	26.73	1.04	0.42	30.52	15.75	3.84
250	17.45	19.99	29.89	29.42	1.04	0.44	31.03	16.18	3.81
300	17.41	20.01	29.70	31.52	1.04	0.45	30.99	16.14	3.86
350	17.37	20.06	28.74	32.64	1.05	0.46	30.94	16.35	3.92
400	17.33	20.11	28.16	33.25	1.05	0.47	31.22	16.39	3.94
450	17.30	20.16	27.32	33.36	1.05	0.48	31.51	16.51	3.88
500	17.28	20.20	26.91	33.57	1.06	0.49	30.96	16.45	3.91
550	17.26	20.18	26.44	33.31	1.06	0.49	30.93	16.34	3.97
600	17.24	20.23	26.00	32.83	1.06	0.50	31.27	16.43	3.90
650	17.23	20.24	25.91	32.52	1.06	0.50	31.21	16.46	3.95
700	17.22	20.24	25.49	32.10	1.06	0.50	31.51	16.52	3.93
750	17.20	20.29	25.31	31.95	1.06	0.51	31.64	16.45	3.87
800	17.19	20.27	25.06	31.32	1.06	0.51	31.55	16.45	3.89
850	17.18	20.26	24.90	30.99	1.06	0.51	31.14	16.40	3.88
1000	17.14	20.30	24.53	29.76	1.06	0.52	30.48	16.36	3.93
1500	17.03	20.40	23.97	26.18	1.07	0.54	30.62	16.32	3.93
2000	16.91	20.44	24.28	23.48	1.08	0.55	29.87	16.21	3.98
2500	16.77	20.53	25.33	21.30	1.09	0.57	28.99	15.80	4.02
3000	16.65	20.58	25.25	19.45	1.10	0.58	28.47	15.69	4.08
3500	16.56	20.63	24.06	18.04	1.10	0.59	27.42	15.56	4.09
4000	16.45	20.70	22.24	17.34	1.11	0.60	26.64	15.22	4.13
4500	16.37	20.79	21.61	17.32	1.12	0.62	25.94	14.98	4.13
5000	16.38	20.81	22.95	17.31	1.12	0.62	25.25	14.54	4.27
5500	16.39	20.73	27.29	16.67	1.11	0.60	24.66	14.05	4.33
6000	16.38	20.66	22.15	15.96	1.11	0.59	24.63	13.56	4.39
6500	16.51	20.68	17.68	13.85	1.09	0.57	24.08	12.91	4.55
7000	16.50	20.79	13.70	11.90	1.07	0.57	23.45	12.16	4.57
7500	16.53	20.80	11.01	10.39	1.04	0.55	23.03	11.38	4.76
8000	16.39	21.00	9.22	9.07	1.01	0.56	21.97	10.46	4.92
8500	15.98	21.29	8.02	8.63	1.01	0.63	21.53	9.61	5.08
9000	15.17	21.88	7.11	8.26	1.03	0.75	20.90	9.22	5.30
9500	14.14	22.22	7.12	8.30	1.11	0.83	19.68	8.37	5.47
10000	12.73	22.01	7.47	9.27	1.23	0.92	19.78	7.79	5.67

Typical Performance Data

Definitions:

Input Return Loss = -S11 (dB)

Gain(Power Gain) = S21 (dB)

Reverse Isolation = -S12 (dB)

Output Return Loss = -S22 (dB)

TEST CONDITIONS: Vd = 4.75V, Id =43.25 mA @ Temperature = +25degC

FREQ	Gain	Isolation	Input Return Loss	Output Return Loss	Stability		IP-3 Output	1dB Comp. Output	Noise Figure
					K	Measure			
(MHz)	(dB)	(dB)	(dB)	(dB)	K	Measure	(dBm)	(dBm)	(dB)
10	14.23	23.53	10.21	12.16	1.35	0.96	--	15.44	7.48
20	14.60	22.49	10.73	12.35	1.24	0.89	18.63	15.65	7.49
30	15.14	21.92	11.31	12.90	1.18	0.81	20.59	15.95	6.62
40	15.65	21.46	12.07	13.60	1.14	0.74	22.73	15.82	5.99
50	16.11	20.99	12.89	14.36	1.11	0.66	25.69	15.42	5.60
60	16.42	20.56	13.78	15.25	1.08	0.60	28.81	15.26	5.24
70	16.69	20.39	14.80	16.08	1.07	0.55	28.64	15.16	4.89
80	16.90	20.23	15.80	17.04	1.06	0.51	28.57	14.58	4.60
90	17.05	20.06	16.84	17.92	1.05	0.48	28.88	14.47	4.50
100	17.16	19.96	17.88	18.87	1.05	0.46	28.49	14.52	4.25
200	17.39	19.79	27.97	26.74	1.04	0.42	29.06	14.51	3.79
250	17.35	19.89	31.19	29.23	1.04	0.44	29.53	15.11	3.76
300	17.31	19.97	31.71	30.97	1.05	0.46	29.30	15.08	3.85
350	17.27	19.99	30.84	31.69	1.05	0.47	29.52	15.27	3.88
400	17.23	20.06	30.12	31.83	1.05	0.48	29.74	15.39	3.86
450	17.21	20.10	28.93	31.80	1.05	0.49	29.79	15.50	3.87
500	17.18	20.11	28.60	31.68	1.06	0.49	29.42	15.47	3.87
550	17.17	20.12	27.94	31.47	1.06	0.49	29.36	15.31	3.95
600	17.14	20.16	27.49	31.11	1.06	0.50	29.71	15.46	3.84
650	17.13	20.16	27.27	30.98	1.06	0.50	29.71	15.51	3.92
700	17.12	20.19	26.79	30.52	1.06	0.51	30.09	15.58	3.87
750	17.10	20.19	26.59	30.31	1.06	0.51	30.08	15.50	3.87
800	17.09	20.20	26.31	29.89	1.06	0.51	29.96	15.50	3.83
850	17.08	20.22	26.10	29.53	1.06	0.52	29.65	15.45	3.82
1000	17.04	20.22	25.60	28.62	1.06	0.52	29.14	15.41	3.86
1500	16.93	20.30	24.95	25.51	1.07	0.54	29.28	15.35	3.88
2000	16.81	20.34	25.25	22.88	1.08	0.55	28.67	15.27	3.93
2500	16.67	20.46	26.20	20.71	1.09	0.57	27.91	14.86	4.01
3000	16.55	20.51	25.71	18.85	1.10	0.58	27.59	14.77	3.98
3500	16.45	20.56	24.11	17.47	1.10	0.59	26.80	14.74	4.03
4000	16.34	20.64	22.22	16.77	1.11	0.60	26.09	14.45	4.01
4500	16.26	20.66	21.66	16.71	1.12	0.61	25.50	14.31	4.07
5000	16.26	20.69	23.24	16.68	1.12	0.61	24.87	13.98	4.24
5500	16.27	20.61	28.41	16.15	1.11	0.60	24.32	13.43	4.28
6000	16.25	20.55	22.65	15.53	1.11	0.59	24.29	13.05	4.37
6500	16.38	20.55	17.83	13.56	1.09	0.57	23.84	12.49	4.44
7000	16.36	20.65	13.70	11.66	1.06	0.57	23.19	11.76	4.50
7500	16.36	20.68	10.99	10.21	1.03	0.56	22.72	11.02	4.69
8000	16.20	20.88	9.21	8.89	1.01	0.57	21.65	10.10	4.80
8500	15.77	21.20	8.03	8.41	1.01	0.64	21.19	9.31	5.00
9000	14.96	21.76	7.12	8.04	1.02	0.75	20.49	8.89	5.20
9500	13.94	22.13	7.13	8.04	1.10	0.83	19.26	8.02	5.37
10000	12.54	21.93	7.45	8.96	1.23	0.91	19.34	7.44	5.56

Typical Performance Data

Definitions:

Input Return Loss = -S11 (dB)
 Gain(Power Gain) = S21 (dB)
 Reverse Isolation = -S12 (dB)
 Output Return Loss = -S22 (dB)

TEST CONDITIONS: Vd = 5.25V, Id = 53.14 mA @ Temperature = +25degC

FREQ	Gain	Isolation	Input Return Loss	Output Return Loss	Stability		IP-3 Output	1dB Comp. Output	Noise Figure
					K	Measure			
(MHz)	(dB)	(dB)	(dB)	(dB)	K	Measure	(dBm)	(dBm)	(dB)
10	14.69	23.46	10.77	12.96	1.32	0.94	--	16.55	7.29
20	15.00	22.56	11.13	13.10	1.22	0.88	18.76	17.35	7.24
30	15.43	22.06	11.66	13.63	1.18	0.81	19.38	17.66	6.57
40	15.85	21.60	12.31	14.25	1.14	0.75	20.01	17.73	6.03
50	16.25	21.18	13.09	14.96	1.11	0.67	20.23	17.53	5.64
60	16.54	20.73	13.83	15.77	1.08	0.61	20.56	17.53	5.30
70	16.81	20.58	14.73	16.52	1.07	0.56	21.36	17.51	4.98
80	17.02	20.37	15.69	17.40	1.06	0.52	22.01	17.31	4.74
90	17.17	20.24	16.68	18.22	1.05	0.49	22.24	17.18	4.61
100	17.29	20.14	17.69	19.08	1.05	0.47	23.39	17.21	4.36
200	17.56	19.94	26.76	26.57	1.04	0.42	29.99	16.94	3.84
250	17.52	20.04	28.54	29.28	1.04	0.44	31.95	17.19	3.87
300	17.48	20.11	28.30	31.45	1.05	0.45	32.09	17.14	3.95
350	17.44	20.08	27.50	32.89	1.05	0.46	32.45	17.27	3.96
400	17.40	20.19	26.89	33.72	1.05	0.47	32.60	17.27	3.96
450	17.38	20.20	26.20	34.17	1.05	0.48	32.82	17.37	3.97
500	17.35	20.22	25.78	34.37	1.05	0.48	32.32	17.35	3.90
550	17.34	20.27	25.42	34.30	1.06	0.49	32.15	17.24	4.03
600	17.31	20.30	25.01	33.90	1.06	0.50	32.55	17.29	3.98
650	17.30	20.31	24.90	33.60	1.06	0.50	32.65	17.33	4.00
700	17.29	20.31	24.56	33.07	1.06	0.50	32.85	17.38	3.94
750	17.27	20.30	24.35	33.03	1.06	0.51	33.16	17.31	3.89
800	17.26	20.33	24.17	32.34	1.06	0.51	32.68	17.30	3.89
850	17.25	20.36	24.04	31.79	1.06	0.51	32.55	17.26	3.94
1000	17.21	20.39	23.65	30.52	1.07	0.52	31.86	17.22	3.99
1500	17.10	20.44	23.20	26.87	1.07	0.54	31.89	17.16	3.98
2000	16.98	20.49	23.58	24.08	1.08	0.55	31.03	17.08	4.03
2500	16.86	20.57	24.66	22.00	1.09	0.57	29.72	16.70	4.10
3000	16.74	20.63	24.83	20.11	1.10	0.58	29.19	16.48	4.08
3500	16.65	20.69	23.85	18.67	1.10	0.59	27.96	16.25	4.13
4000	16.55	20.77	22.11	17.97	1.11	0.60	27.02	15.86	4.17
4500	16.48	20.87	21.44	17.96	1.12	0.62	26.29	15.54	4.20
5000	16.49	20.88	22.62	17.99	1.12	0.62	25.59	15.03	4.35
5500	16.50	20.84	26.43	17.33	1.12	0.61	25.03	14.50	4.39
6000	16.50	20.73	21.90	16.46	1.11	0.59	24.92	13.95	4.47
6500	16.65	20.80	17.72	14.20	1.09	0.57	24.33	13.23	4.59
7000	16.65	20.88	13.77	12.17	1.07	0.57	23.67	12.44	4.61
7500	16.70	20.91	11.04	10.61	1.04	0.55	23.24	11.66	4.86
8000	16.58	21.09	9.24	9.26	1.02	0.55	22.17	10.71	4.97
8500	16.19	21.41	8.04	8.83	1.01	0.63	21.74	9.88	5.17
9000	15.39	21.99	7.11	8.51	1.03	0.75	21.15	9.47	5.41
9500	14.36	22.37	7.15	8.56	1.12	0.83	20.03	8.64	5.60
10000	12.94	22.11	7.50	9.61	1.24	0.92	20.16	8.08	5.82

Typical Performance Data

Definitions:

Input Return Loss = -S11 (dB)

Gain(Power Gain) = S21 (dB)

Reverse Isolation = -S12 (dB)

Output Return Loss = -S22 (dB)

TEST CONDITIONS: Vd = 5V, Id = 44.11 mA @ Temperature = -45degC

FREQ	Gain	Isolation	Input Return Loss	Output Return Loss	Stability		IP-3 Output	1dB Comp. Output	Noise Figure
					K	Measure			
(MHz)	(dB)	(dB)	(dB)	(dB)	K	Measure	(dBm)	(dBm)	(dB)
10	14.35	24.02	9.76	12.22	1.37	0.98	--	15.90	6.65
20	14.74	22.68	10.18	12.44	1.23	0.90	19.64	16.22	6.75
30	15.31	22.13	10.79	12.93	1.18	0.82	22.70	16.52	5.87
40	15.84	21.63	11.58	13.54	1.14	0.74	25.95	16.33	5.24
50	16.31	21.28	12.47	14.25	1.11	0.67	29.58	15.57	4.82
60	16.64	20.70	13.35	15.09	1.08	0.59	30.67	15.37	4.50
70	16.93	20.57	14.45	15.82	1.07	0.54	30.04	15.27	4.15
80	17.14	20.35	15.48	16.74	1.06	0.50	29.74	14.67	3.88
90	17.30	20.22	16.56	17.57	1.05	0.47	29.70	14.52	3.77
100	17.42	20.12	17.64	18.46	1.04	0.44	29.33	14.60	3.55
200	17.68	19.95	27.64	26.25	1.03	0.40	29.88	14.66	3.06
250	17.64	20.05	29.59	28.55	1.04	0.42	30.34	15.31	3.09
300	17.60	20.10	28.13	29.82	1.04	0.44	30.16	15.21	3.16
350	17.56	20.14	26.64	30.38	1.04	0.45	30.40	15.57	3.21
400	17.53	20.19	25.85	30.99	1.05	0.46	30.58	15.73	3.19
450	17.50	20.21	25.29	31.49	1.05	0.47	30.82	15.79	3.17
500	17.48	20.25	25.18	32.25	1.05	0.47	30.35	15.70	3.16
550	17.47	20.26	25.02	32.08	1.05	0.48	30.30	15.55	3.17
600	17.45	20.27	24.77	31.52	1.05	0.48	30.66	15.77	3.13
650	17.44	20.31	24.67	30.77	1.05	0.49	30.66	15.85	3.19
700	17.43	20.32	24.23	30.13	1.05	0.49	30.91	15.90	3.18
750	17.42	20.34	23.95	30.08	1.05	0.49	30.83	15.78	3.12
800	17.40	20.32	23.83	29.78	1.05	0.49	30.86	15.82	3.10
850	17.39	20.33	23.92	29.96	1.05	0.49	30.44	15.69	3.11
1000	17.36	20.38	24.55	29.09	1.06	0.50	29.97	15.65	3.16
1500	17.26	20.40	22.20	24.59	1.06	0.51	30.24	15.69	3.14
2000	17.16	20.47	22.67	22.86	1.07	0.53	29.78	15.55	3.19
2500	17.04	20.54	23.65	20.25	1.08	0.54	29.05	15.13	3.28
3000	16.94	20.58	25.37	18.48	1.08	0.55	28.90	15.15	3.23
3500	16.86	20.62	25.29	16.99	1.09	0.55	28.06	15.13	3.23
4000	16.77	20.69	23.44	16.17	1.09	0.56	27.44	15.10	3.24
4500	16.72	20.72	22.49	15.84	1.09	0.57	26.72	14.94	3.29
5000	16.73	20.72	22.81	15.68	1.09	0.56	26.01	14.87	3.43
5500	16.74	20.64	22.48	14.65	1.08	0.55	25.54	14.27	3.44
6000	16.82	20.65	19.06	13.99	1.08	0.53	25.44	14.16	3.53
6500	17.03	20.72	16.21	12.00	1.06	0.49	25.11	13.76	3.60
7000	17.04	20.75	13.04	10.08	1.03	0.46	24.46	13.16	3.65
7500	17.20	20.80	10.07	8.39	1.00	0.39	23.85	12.47	3.86
8000	17.20	21.04	8.58	7.29	0.96	0.39	22.94	11.46	3.96
8500	17.13	21.21	7.55	6.59	0.94	0.39	22.43	10.59	4.10
9000	16.80	21.94	6.74	6.08	0.92	0.49	21.59	10.06	4.28
9500	16.13	22.39	6.76	6.09	0.97	0.56	20.58	9.14	4.40
10000	14.82	22.00	7.79	7.38	1.11	0.66	20.79	8.59	4.62

Typical Performance Data

Definitions:

Input Return Loss = -S11 (dB)

Gain(Power Gain) = S21 (dB)

Reverse Isolation = -S12 (dB)

Output Return Loss = -S22 (dB)

TEST CONDITIONS: Vd = 4.75V, Id =39.04 mA @ Temperature = -45degC

FREQ	Gain	Isolation	Input Return Loss	Output Return Loss	Stability		IP-3 Output	1dB Comp. Output	Noise Figure
					K	Measure			
(MHz)	(dB)	(dB)	(dB)	(dB)	K	Measure	(dBm)	(dBm)	(dB)
10	14.30	23.78	9.87	12.10	1.35	0.97	--	14.81	6.50
20	14.66	22.50	10.47	12.28	1.22	0.89	33.28	15.20	6.57
30	15.22	22.13	11.05	12.82	1.19	0.82	29.82	15.24	5.75
40	15.75	21.55	11.84	13.42	1.14	0.74	27.99	14.00	5.11
50	16.21	21.15	12.70	14.16	1.11	0.67	27.93	13.37	4.76
60	16.54	20.62	13.69	14.99	1.08	0.59	28.32	13.21	4.41
70	16.82	20.49	14.71	15.76	1.07	0.55	27.90	13.20	4.08
80	17.03	20.29	15.75	16.68	1.06	0.50	27.45	12.81	3.82
90	17.19	20.15	16.79	17.54	1.05	0.47	27.74	12.83	3.71
100	17.31	20.02	17.84	18.44	1.04	0.44	27.17	12.99	3.49
200	17.56	19.87	27.99	26.26	1.03	0.41	27.62	13.23	3.04
250	17.53	19.96	31.29	28.65	1.04	0.43	28.42	13.86	3.05
300	17.49	20.02	30.19	30.18	1.04	0.44	28.14	13.80	3.19
350	17.45	20.04	28.40	30.64	1.04	0.45	28.49	14.16	3.17
400	17.42	20.12	27.54	31.18	1.05	0.46	28.46	14.26	3.13
450	17.39	20.14	26.81	31.65	1.05	0.47	28.76	14.45	3.10
500	17.37	20.15	26.71	31.94	1.05	0.47	28.34	14.35	3.12
550	17.36	20.20	26.48	31.58	1.05	0.48	28.26	14.19	3.15
600	17.34	20.21	26.17	30.90	1.05	0.49	28.53	14.49	3.14
650	17.33	20.22	26.06	30.04	1.05	0.49	28.61	14.50	3.16
700	17.32	20.24	25.60	29.35	1.05	0.49	28.86	14.58	3.10
750	17.31	20.24	25.28	29.36	1.05	0.49	28.90	14.42	3.09
800	17.30	20.28	25.10	29.14	1.06	0.50	28.86	14.52	3.06
850	17.29	20.26	25.21	29.10	1.06	0.50	28.55	14.37	3.07
1000	17.26	20.27	25.92	28.04	1.06	0.50	28.02	14.32	3.14
1500	17.15	20.32	23.16	24.23	1.06	0.52	28.50	14.34	3.12
2000	17.05	20.36	23.72	22.45	1.07	0.53	27.92	14.24	3.13
2500	16.92	20.44	24.76	19.75	1.08	0.54	27.35	13.85	3.19
3000	16.82	20.52	26.46	17.95	1.08	0.55	27.39	13.94	3.18
3500	16.73	20.51	25.93	16.44	1.08	0.55	26.90	13.97	3.19
4000	16.64	20.57	23.70	15.61	1.09	0.56	26.46	14.01	3.19
4500	16.60	20.62	22.84	15.29	1.09	0.56	25.96	13.99	3.22
5000	16.60	20.61	23.51	15.12	1.09	0.56	25.35	14.05	3.36
5500	16.61	20.50	23.21	14.19	1.08	0.54	24.82	13.39	3.42
6000	16.68	20.53	19.39	13.61	1.08	0.53	24.83	13.46	3.47
6500	16.88	20.56	16.29	11.71	1.05	0.49	24.58	13.14	3.56
7000	16.87	20.58	13.02	9.87	1.02	0.46	23.97	12.63	3.59
7500	17.03	20.61	10.06	8.24	0.99	0.39	23.33	12.01	3.81
8000	16.99	20.83	8.57	7.11	0.95	0.39	22.50	11.08	3.90
8500	16.89	21.06	7.55	6.43	0.93	0.39	21.98	10.17	4.02
9000	16.54	21.75	6.78	5.95	0.91	0.49	21.08	9.72	4.20
9500	15.85	22.19	6.79	5.89	0.96	0.56	20.09	8.82	4.32
10000	14.58	21.93	7.69	7.06	1.11	0.66	20.24	8.24	4.55

Typical Performance Data

Definitions:

Input Return Loss = -S11 (dB)
 Gain(Power Gain) = S21 (dB)
 Reverse Isolation = -S12 (dB)
 Output Return Loss = -S22 (dB)

TEST CONDITIONS: Vd = 5.25V, Id = 48.74 mA @ Temperature = -45degC

FREQ	Gain	Isolation	Input Return Loss	Output Return Loss	Stability		IP-3 Output	1dB Comp. Output	Noise Figure
					K	Measure			
(MHz)	(dB)	(dB)	(dB)	(dB)	K	Measure	(dBm)	(dBm)	(dB)
10	14.39	22.94	9.64	11.84	1.23	0.95	--	16.37	6.82
20	14.79	22.81	9.99	12.52	1.23	0.91	16.54	17.10	6.88
30	15.37	22.21	10.62	13.01	1.18	0.83	17.65	17.41	5.96
40	15.90	21.69	11.41	13.60	1.14	0.75	18.83	17.38	5.32
50	16.38	21.36	12.26	14.25	1.11	0.67	20.33	17.11	4.90
60	16.71	21.02	13.29	15.11	1.09	0.61	23.53	17.01	4.59
70	17.00	20.65	14.29	15.87	1.07	0.55	26.67	16.93	4.20
80	17.21	20.47	15.34	16.77	1.06	0.50	29.62	16.28	3.94
90	17.38	20.31	16.40	17.61	1.05	0.47	30.49	16.12	3.83
100	17.49	20.21	17.47	18.44	1.04	0.44	30.58	16.12	3.63
200	17.75	20.03	27.11	26.08	1.03	0.40	31.20	15.80	3.16
250	17.72	20.07	28.53	28.36	1.04	0.42	31.92	16.40	3.11
300	17.67	20.17	27.04	29.27	1.04	0.44	31.85	16.33	3.21
350	17.63	20.26	25.51	29.39	1.04	0.45	31.74	16.62	3.25
400	17.60	20.25	24.91	30.19	1.05	0.46	32.07	16.70	3.18
450	17.57	20.27	24.36	30.83	1.05	0.46	32.50	16.81	3.19
500	17.55	20.34	24.30	31.55	1.05	0.47	31.80	16.75	3.18
550	17.54	20.32	24.14	31.67	1.05	0.47	31.85	16.62	3.26
600	17.52	20.31	23.94	31.31	1.05	0.48	31.76	16.75	3.18
650	17.51	20.36	23.84	30.59	1.05	0.48	32.00	16.82	3.23
700	17.50	20.36	23.42	30.10	1.05	0.48	32.44	16.87	3.19
750	17.48	20.38	23.21	30.15	1.05	0.49	32.40	16.78	3.16
800	17.47	20.39	23.04	30.00	1.05	0.49	32.37	16.80	3.14
850	17.46	20.41	23.19	30.12	1.06	0.49	32.09	16.71	3.13
1000	17.43	20.41	23.75	29.62	1.06	0.50	31.34	16.65	3.21
1500	17.33	20.45	21.57	24.79	1.06	0.51	31.67	16.69	3.18
2000	17.23	20.52	22.07	23.14	1.07	0.53	31.00	16.55	3.21
2500	17.12	20.57	22.97	20.61	1.08	0.54	30.07	16.11	3.30
3000	17.02	20.63	24.73	18.95	1.08	0.55	29.86	16.10	3.28
3500	16.94	20.65	24.82	17.45	1.08	0.55	28.95	15.99	3.26
4000	16.86	20.76	23.19	16.62	1.09	0.56	28.12	15.83	3.29
4500	16.81	20.80	22.13	16.32	1.10	0.57	27.21	15.61	3.30
5000	16.82	20.81	22.41	16.14	1.10	0.57	26.42	15.48	3.49
5500	16.85	20.71	22.04	15.04	1.09	0.55	25.88	14.95	3.48
6000	16.92	20.76	18.71	14.36	1.08	0.54	25.76	14.69	3.56
6500	17.16	20.81	16.13	12.26	1.06	0.49	25.38	14.25	3.66
7000	17.17	20.87	13.05	10.29	1.03	0.46	24.70	13.56	3.69
7500	17.35	20.88	10.11	8.56	1.00	0.39	24.16	12.83	3.93
8000	17.40	21.12	8.60	7.41	0.96	0.38	23.21	11.78	4.01
8500	17.34	21.34	7.57	6.72	0.94	0.38	22.71	10.88	4.19
9000	17.00	21.99	6.78	6.29	0.93	0.49	21.96	10.41	4.33
9500	16.33	22.41	6.80	6.26	0.97	0.56	20.97	9.45	4.45
10000	15.05	22.18	7.74	7.56	1.11	0.67	21.12	8.93	4.71

Typical Performance Data

Definitions:

Input Return Loss = -S11 (dB)

Gain(Power Gain) = S21 (dB)

Reverse Isolation = -S12 (dB)

Output Return Loss = -S22 (dB)

TEST CONDITIONS: Vd = 5V, Id = 51.35 mA @ Temperature = +85degC

FREQ	Gain	Isolation	Input Return Loss	Output Return Loss	Stability		IP-3 Output	1dB Comp. Output	Noise Figure
					K	Measure			
(MHz)	(dB)	(dB)	(dB)	(dB)	K	Measure	(dBm)	(dBm)	(dB)
10	14.59	22.78	11.62	12.64	1.27	0.90	--	16.21	7.58
20	14.90	22.17	11.63	13.19	1.21	0.86	19.01	16.86	7.64
30	15.31	21.84	12.15	13.73	1.18	0.80	19.62	17.19	6.94
40	15.72	21.41	12.79	14.38	1.14	0.74	20.26	17.26	6.46
50	16.10	21.16	13.54	15.10	1.12	0.68	20.54	17.07	6.10
60	16.37	20.69	14.19	15.99	1.09	0.62	20.96	17.03	5.77
70	16.63	20.45	15.10	16.81	1.08	0.57	21.81	17.01	5.49
80	16.83	20.25	16.01	17.74	1.06	0.53	22.52	16.81	5.21
90	16.98	20.13	16.94	18.61	1.06	0.50	22.73	16.71	5.10
100	17.10	20.04	17.92	19.54	1.05	0.48	23.94	16.71	4.84
200	17.35	19.85	26.66	27.12	1.04	0.43	29.90	16.54	4.30
250	17.31	19.90	28.58	30.03	1.04	0.45	31.36	16.72	4.37
300	17.27	19.97	29.04	32.41	1.05	0.46	31.73	16.71	4.50
350	17.23	20.04	28.81	33.47	1.05	0.48	31.58	16.82	4.50
400	17.19	20.05	28.62	33.75	1.05	0.48	32.06	16.80	4.49
450	17.17	20.08	27.78	33.85	1.06	0.49	32.36	16.89	4.47
500	17.14	20.14	27.37	33.81	1.06	0.50	31.73	16.88	4.47
550	17.12	20.14	26.83	33.10	1.06	0.50	31.46	16.76	4.53
600	17.10	20.14	26.38	32.94	1.06	0.51	31.97	16.79	4.46
650	17.09	20.15	26.40	32.62	1.06	0.51	32.17	16.83	4.53
700	17.07	20.22	26.10	32.03	1.06	0.52	32.14	16.87	4.50
750	17.06	20.18	26.18	31.82	1.06	0.51	31.97	16.80	4.40
800	17.04	20.20	26.11	31.15	1.06	0.52	32.33	16.79	4.42
850	17.03	20.24	25.93	31.00	1.07	0.52	31.81	16.77	4.46
1000	16.99	20.22	25.65	29.85	1.07	0.53	30.87	16.69	4.51
1500	16.87	20.30	25.49	27.08	1.08	0.54	30.95	16.64	4.55
2000	16.75	20.36	25.22	24.65	1.09	0.56	29.95	16.53	4.59
2500	16.61	20.47	25.34	22.45	1.10	0.58	28.93	16.14	4.66
3000	16.48	20.54	24.47	20.55	1.11	0.60	28.16	15.84	4.70
3500	16.36	20.59	22.77	19.15	1.11	0.61	27.18	15.53	4.67
4000	16.23	20.68	20.77	18.41	1.12	0.62	26.47	15.03	4.75
4500	16.14	20.69	20.64	18.59	1.13	0.63	25.77	14.62	4.78
5000	16.11	20.79	22.08	19.14	1.14	0.65	25.11	13.95	4.96
5500	16.07	20.67	33.03	18.76	1.13	0.64	24.61	13.25	4.97
6000	16.07	20.69	25.38	18.19	1.13	0.64	24.16	12.62	5.07
6500	15.92	20.49	17.21	15.57	1.12	0.63	23.46	11.87	5.24
7000	15.87	20.87	13.34	14.04	1.11	0.68	22.64	11.11	5.21
7500	15.82	20.76	10.99	12.81	1.08	0.67	21.99	10.35	5.47
8000	15.39	21.07	9.46	11.74	1.08	0.74	20.92	9.56	5.59
8500	14.84	21.30	8.30	11.17	1.10	0.80	20.22	8.76	5.78
9000	13.85	22.05	7.20	10.14	1.16	0.91	19.66	8.38	6.09
9500	12.53	22.25	7.28	10.36	1.31	0.96	18.48	7.61	6.33
10000	10.93	22.09	7.38	11.02	1.47	1.03	18.34	7.00	6.62

Typical Performance Data

Definitions:

Input Return Loss = -S11 (dB)
 Gain(Power Gain) = S21 (dB)
 Reverse Isolation = -S12 (dB)
 Output Return Loss = -S22 (dB)

TEST CONDITIONS: Vd = 4.75V, Id = 46.26 mA @ Temperature = +85degC

FREQ	Gain	Isolation	Input Return Loss	Output Return Loss	Stability		IP-3 Output	1dB Comp. Output	Noise Figure
					K	Measure			
(MHz)	(dB)	(dB)	(dB)	(dB)	K	Measure	(dBm)	(dBm)	(dB)
10	14.16	22.16	10.85	11.57	1.20	0.90	--	15.92	8.03
20	14.56	22.34	10.98	12.45	1.23	0.88	17.15	16.08	8.08
30	15.09	21.82	11.56	13.00	1.18	0.81	18.09	16.37	7.19
40	15.59	21.35	12.31	13.71	1.14	0.74	19.05	16.37	6.57
50	16.03	20.94	13.12	14.49	1.11	0.67	20.03	16.06	6.19
60	16.33	20.69	13.98	15.47	1.10	0.62	21.78	16.01	5.79
70	16.59	20.34	14.96	16.35	1.07	0.56	23.46	15.97	5.44
80	16.79	20.14	15.94	17.36	1.06	0.52	25.30	15.65	5.18
90	16.94	20.04	16.93	18.31	1.06	0.49	26.38	15.51	5.07
100	17.05	19.94	17.91	19.26	1.05	0.47	27.42	15.52	4.82
200	17.27	19.77	27.48	27.32	1.04	0.44	29.73	15.37	4.31
250	17.23	19.81	30.23	30.18	1.04	0.45	30.17	15.73	4.35
300	17.18	19.89	30.96	31.97	1.05	0.46	30.13	15.70	4.44
350	17.13	19.97	30.83	32.08	1.05	0.48	29.98	15.90	4.43
400	17.10	20.00	30.55	31.71	1.06	0.49	30.37	15.92	4.44
450	17.07	20.02	29.49	31.86	1.06	0.49	30.55	15.98	4.43
500	17.05	20.05	28.98	31.50	1.06	0.50	30.16	15.99	4.48
550	17.03	20.06	28.35	31.10	1.06	0.50	30.17	15.87	4.47
600	17.01	20.08	27.76	30.94	1.06	0.51	30.37	15.91	4.44
650	16.99	20.11	27.79	30.51	1.06	0.51	30.57	15.95	4.47
700	16.98	20.10	27.57	30.05	1.06	0.51	30.52	16.01	4.48
750	16.96	20.12	27.51	29.78	1.06	0.52	30.57	15.92	4.38
800	16.95	20.15	27.51	29.33	1.07	0.52	30.62	15.90	4.38
850	16.94	20.15	27.27	29.09	1.07	0.52	30.29	15.90	4.42
1000	16.89	20.16	26.87	28.26	1.07	0.53	29.73	15.82	4.49
1500	16.78	20.23	26.58	25.81	1.08	0.55	29.72	15.75	4.51
2000	16.65	20.31	26.08	23.65	1.09	0.56	29.06	15.67	4.54
2500	16.50	20.36	25.96	21.60	1.10	0.58	27.98	15.29	4.61
3000	16.37	20.42	24.76	19.68	1.11	0.59	27.60	15.08	4.63
3500	16.24	20.53	22.74	18.37	1.12	0.61	26.61	14.89	4.65
4000	16.12	20.60	20.75	17.70	1.13	0.62	26.02	14.45	4.70
4500	16.02	20.64	20.65	17.79	1.13	0.64	25.46	14.10	4.74
5000	15.99	20.70	22.23	18.19	1.14	0.64	24.83	13.52	4.88
5500	15.95	20.56	34.47	17.88	1.13	0.64	24.34	12.88	4.90
6000	15.94	20.58	25.54	17.46	1.13	0.64	23.96	12.29	4.99
6500	15.88	20.39	17.82	15.64	1.11	0.62	23.24	11.56	5.15
7000	15.72	20.71	13.30	13.64	1.10	0.68	22.51	10.82	5.14
7500	15.66	20.63	11.00	12.54	1.07	0.67	21.79	10.08	5.37
8000	15.22	20.88	9.49	11.41	1.07	0.74	20.68	9.37	5.49
8500	14.65	21.13	8.34	10.77	1.10	0.79	19.97	8.49	5.68
9000	13.66	21.94	7.20	9.74	1.15	0.90	19.35	8.15	5.98
9500	12.32	22.12	7.33	9.97	1.31	0.95	18.16	7.36	6.19
10000	10.74	21.96	7.36	10.60	1.47	1.02	17.97	6.67	6.49

Typical Performance Data

Definitions:

Input Return Loss = -S11 (dB)
 Gain(Power Gain) = S21 (dB)
 Reverse Isolation = -S12 (dB)
 Output Return Loss = -S22 (dB)

TEST CONDITIONS: Vd = 5.25V, Id = 57.82 mA @ Temperature = +85degC

FREQ	Gain	Isolation	Input Return Loss	Output Return Loss	Stability		IP-3 Output	1dB Comp. Output	Noise Figure
					K	Measure			
(MHz)	(dB)	(dB)	(dB)	(dB)	K	Measure	(dBm)	(dBm)	(dB)
10	16.25	20.64	17.54	19.35	1.09	0.66	--	16.34	5.06
20	16.27	20.97	17.03	20.65	1.11	0.69	22.19	16.91	5.20
30	16.36	20.97	17.26	20.87	1.11	0.68	22.29	17.40	5.09
40	16.45	20.83	17.60	21.09	1.10	0.65	22.72	17.70	5.01
50	16.57	20.78	18.06	21.41	1.10	0.64	22.99	17.69	4.96
60	16.63	20.76	18.43	22.09	1.10	0.63	23.55	17.80	4.88
70	16.73	20.55	18.87	22.54	1.08	0.59	24.49	17.84	4.80
80	16.82	20.51	19.32	23.24	1.08	0.58	25.08	17.76	4.73
90	16.90	20.41	19.84	23.79	1.07	0.56	25.40	17.72	4.73
100	16.98	20.36	20.34	24.43	1.07	0.54	26.82	17.76	4.59
200	17.28	20.10	24.88	29.91	1.05	0.48	37.37	17.66	4.43
250	17.29	20.05	25.96	32.10	1.05	0.47	37.05	17.72	4.44
300	17.27	20.13	26.42	34.24	1.05	0.48	34.35	17.75	4.52
350	17.25	20.15	26.43	35.09	1.05	0.49	34.37	17.74	4.56
400	17.23	20.13	26.35	35.53	1.05	0.49	34.74	17.72	4.55
450	17.21	20.19	25.91	35.93	1.06	0.50	34.73	17.76	4.51
500	17.19	20.20	25.61	35.82	1.06	0.50	33.50	17.78	4.57
550	17.18	20.22	25.33	35.27	1.06	0.51	33.82	17.64	4.59
600	17.16	20.26	24.98	35.05	1.06	0.51	33.52	17.64	4.58
650	17.15	20.26	25.00	34.54	1.06	0.51	33.81	17.67	4.59
700	17.14	20.28	24.84	34.02	1.06	0.52	33.48	17.73	4.56
750	17.13	20.29	24.93	33.98	1.06	0.52	33.52	17.63	4.52
800	17.11	20.29	24.89	33.24	1.07	0.52	33.60	17.62	4.49
850	17.10	20.29	24.75	32.92	1.07	0.52	33.09	17.63	4.53
1000	17.06	20.32	24.62	31.73	1.07	0.53	31.97	17.53	4.58
1500	16.95	20.35	24.63	28.50	1.08	0.54	31.68	17.48	4.59
2000	16.83	20.40	24.44	25.80	1.08	0.56	30.57	17.36	4.66
2500	16.69	20.49	24.71	23.52	1.10	0.58	29.13	16.93	4.75
3000	16.56	20.53	24.20	21.49	1.10	0.59	28.42	16.56	4.79
3500	16.44	20.63	22.73	20.09	1.11	0.61	27.27	16.12	4.78
4000	16.32	20.76	20.80	19.32	1.13	0.63	26.51	15.55	4.82
4500	16.22	20.74	20.60	19.64	1.13	0.63	25.82	15.03	4.89
5000	16.19	20.87	22.01	20.29	1.14	0.65	25.11	14.32	5.01
5500	16.14	20.76	31.89	19.94	1.14	0.64	24.66	13.49	5.11
6000	16.15	20.73	25.33	19.18	1.13	0.64	24.02	12.86	5.17
6500	16.20	20.65	18.44	17.02	1.12	0.62	23.18	12.07	5.32
7000	15.95	20.96	13.35	14.56	1.11	0.68	22.47	11.32	5.33
7500	15.93	20.87	11.05	13.38	1.09	0.68	21.75	10.56	5.56
8000	15.50	21.13	9.53	12.28	1.09	0.74	20.80	9.80	5.75
8500	14.95	21.35	8.41	11.65	1.11	0.80	20.12	8.95	5.94
9000	13.97	22.22	7.18	10.52	1.18	0.91	19.61	8.59	6.21
9500	12.59	22.20	7.41	10.96	1.32	0.97	18.55	7.85	6.53
10000	11.00	22.07	7.41	11.52	1.47	1.04	18.43	7.20	6.86

Typical Performance Curves

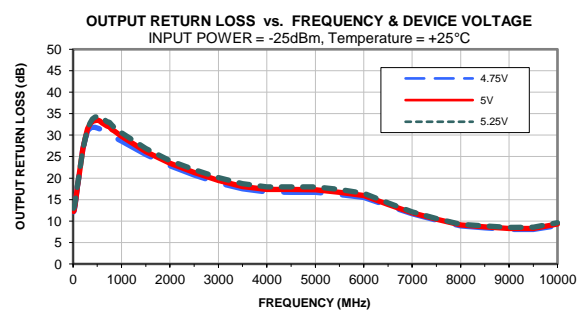
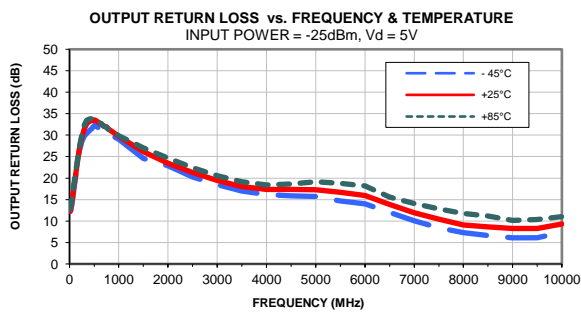
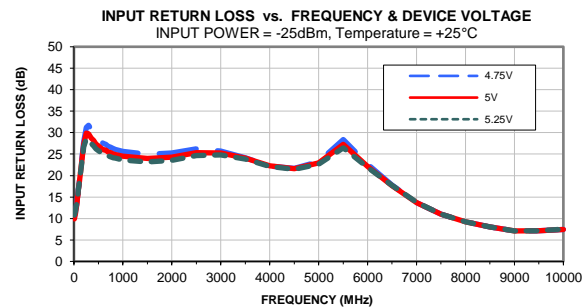
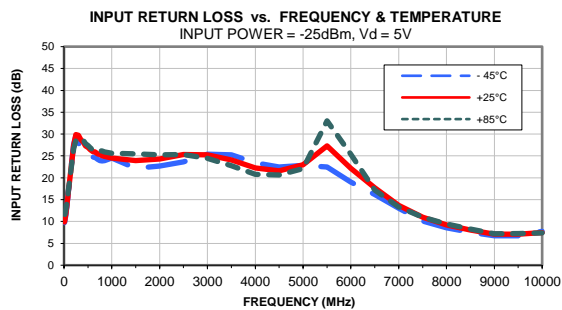
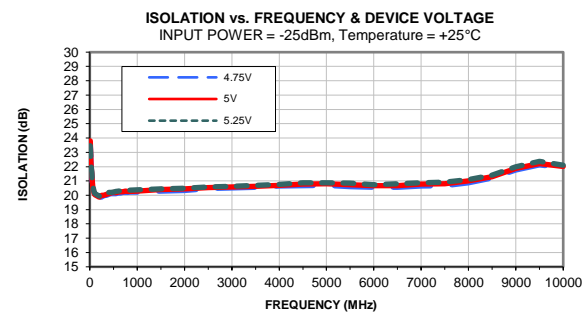
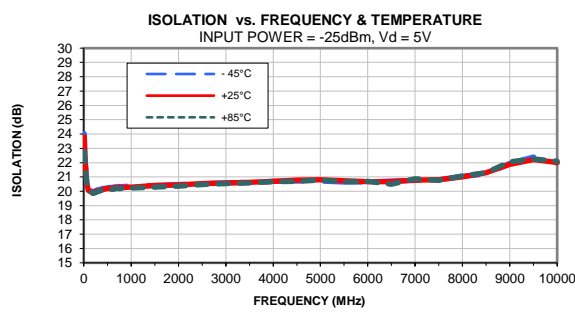
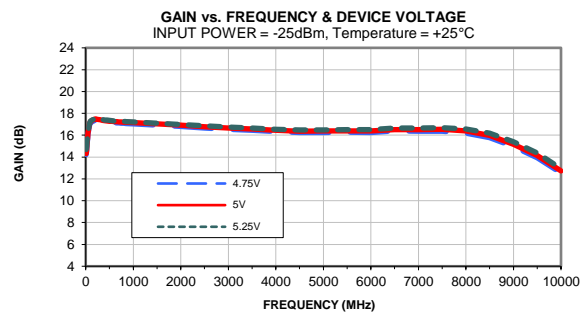
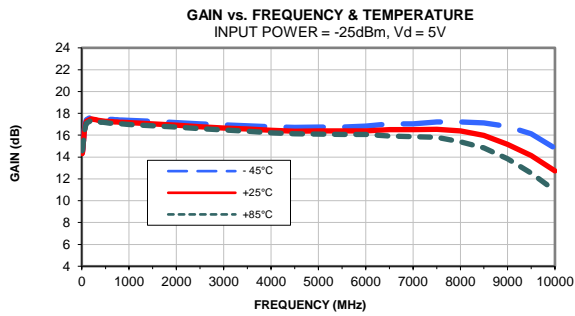

Typical Performance Curves

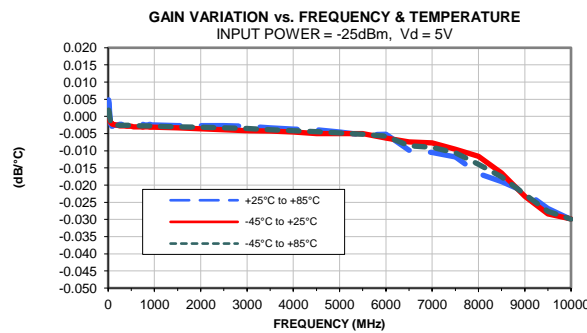
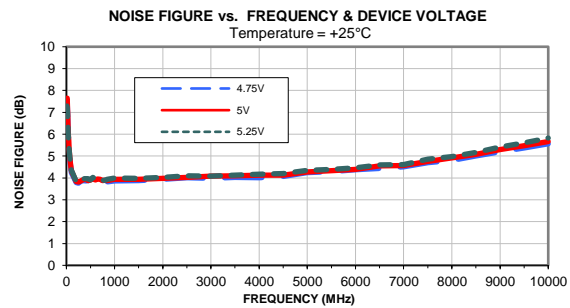
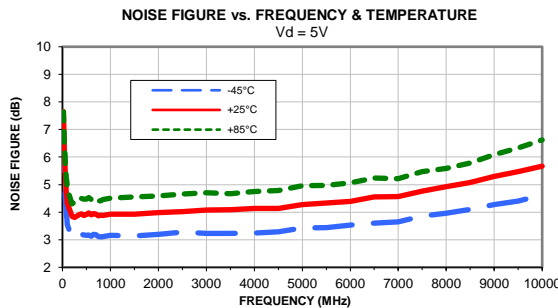
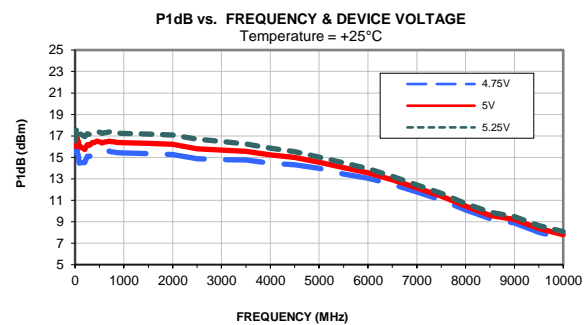
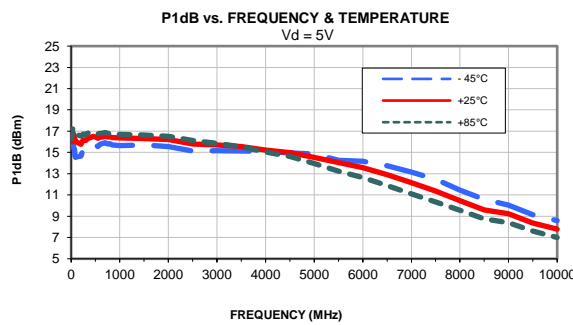
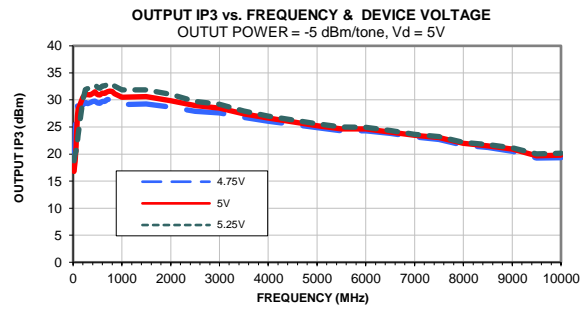
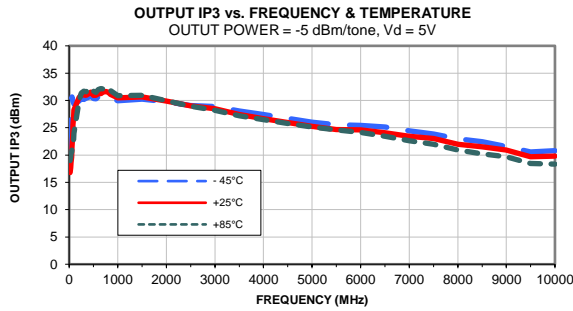

Outline Dimensions

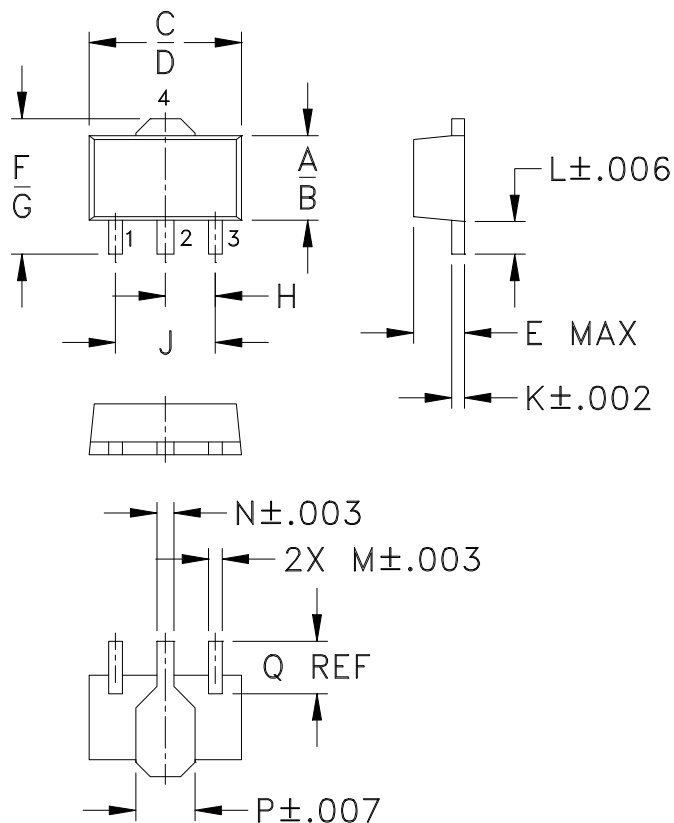

PCB Land Pattern

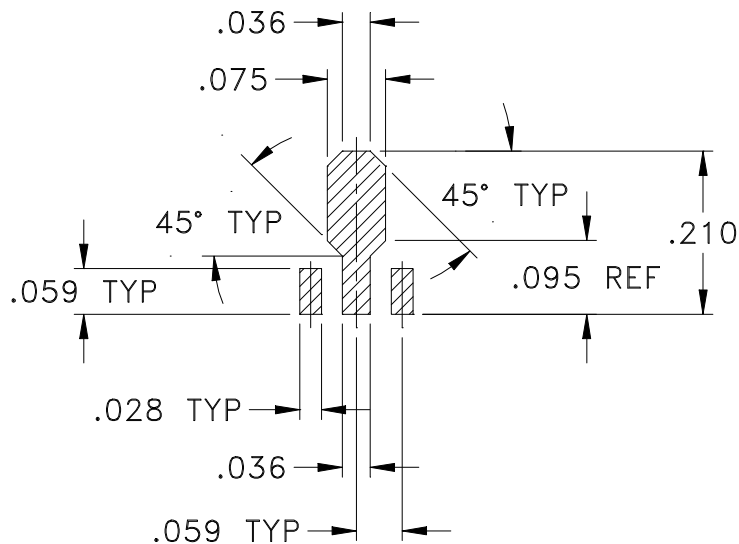

Suggested Layout,
Tolerance to be within $\pm .002$

CASE #	A	B	C	D	E	F	G	H	J	K	L	M
DF782	.102 (2.59)	.090 (2.29)	.181 (4.60)	.173 (4.39)	.063 (1.60)	.167 (4.24)	.155 (3.94)	.059 (1.50)	.118 (3.00)	.015 (0.38)	.041 (1.04)	.016 (0.41)

CASE #	N	P	Q	WT. GRAM
DF782	.019 (0.48)	.065 (1.65)	.062 (1.57)	.2

Dimensions are in inches (mm). Tolerances: 2 Pl. $\pm .01$; 3Pl. $\pm .005$

Notes:

- Case material: Plastic.
- Termination finish:
For RoHS Case Styles: Tin-Silver alloy plate over Nickel barrier or Matte-Tin.
All models, (+) suffix. See model Data sheet.
For RoHS-5 Case Styles: Tin-Lead plate. All models, no (+) suffix.



INTERNET <http://www.minicircuits.com>

P.O. Box 350166, Brooklyn, New York 11235-0003 (718) 934-4500 Fax (718) 332-4661

Distribution Centers NORTH AMERICA 800-654-7949 • 417-335-5935 • Fax 417-335-5945 • EUROPE 44-1252-832600 • Fax 44-1252-837010

Mini-Circuits ISO 9001 & ISO 14001 Certified

Tape & Reel Packaging TR-F55

DEVICE ORIENTATION IN T&R

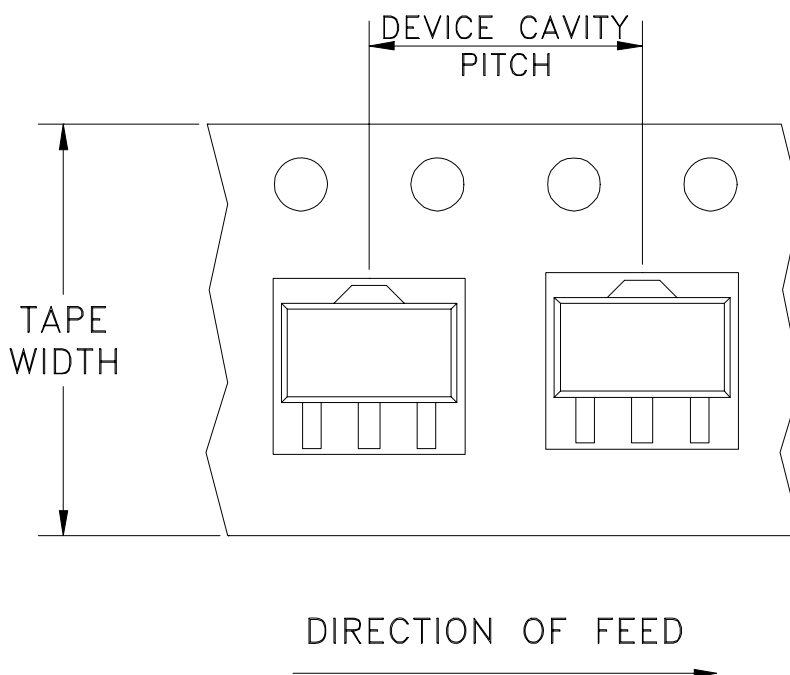

Tape Width, mm	Device Cavity Pitch, mm	Reel Size, inches	Devices per Reel	
12	8	7	Small quantity standard (see note)	20
				50
				100
				200
				500
			Standard	1000

Note: Please consult individual model data sheet to determine device per reel availability.

Mini-Circuits carrier tape materials provide protection from ESD (Electro-Static Discharge) during handling and transportation. Tapes are static dissipative and comply with industry standards EIA-481/EIA-541.

Go to: www.minicircuits.com/pages/pdfs/tape.pdf



INTERNET <http://www.minicircuits.com>

P.O. Box 350166, Brooklyn, New York 11235-0003 (718) 934-4500 Fax (718) 332-4661

Distribution Centers NORTH AMERICA 800-654-7949 • 417-335-5935 • Fax 417-335-5945 • EUROPE 44-1252-832600 • Fax 44-1252-837010

Mini-Circuits ISO 9001 & ISO 14001 Certified

THIRD ANGLE PROJECTION

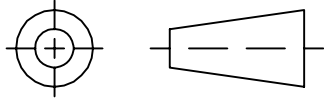

REVISIONS

REV	ECN No.	DESCRIPTION	DATE	DR	AUTH
OR	M137326	NEW RELEASE	07/10/12	PW	DJ

SUGGESTED MOUNTING CONFIGURATION
FOR DF782 CASE STYLE, "04AM03" PIN CODE

32X ϕ .010 PTH FOR GROUND. TO AVOID SOLDER WICKING, PLUG THESE HOLES

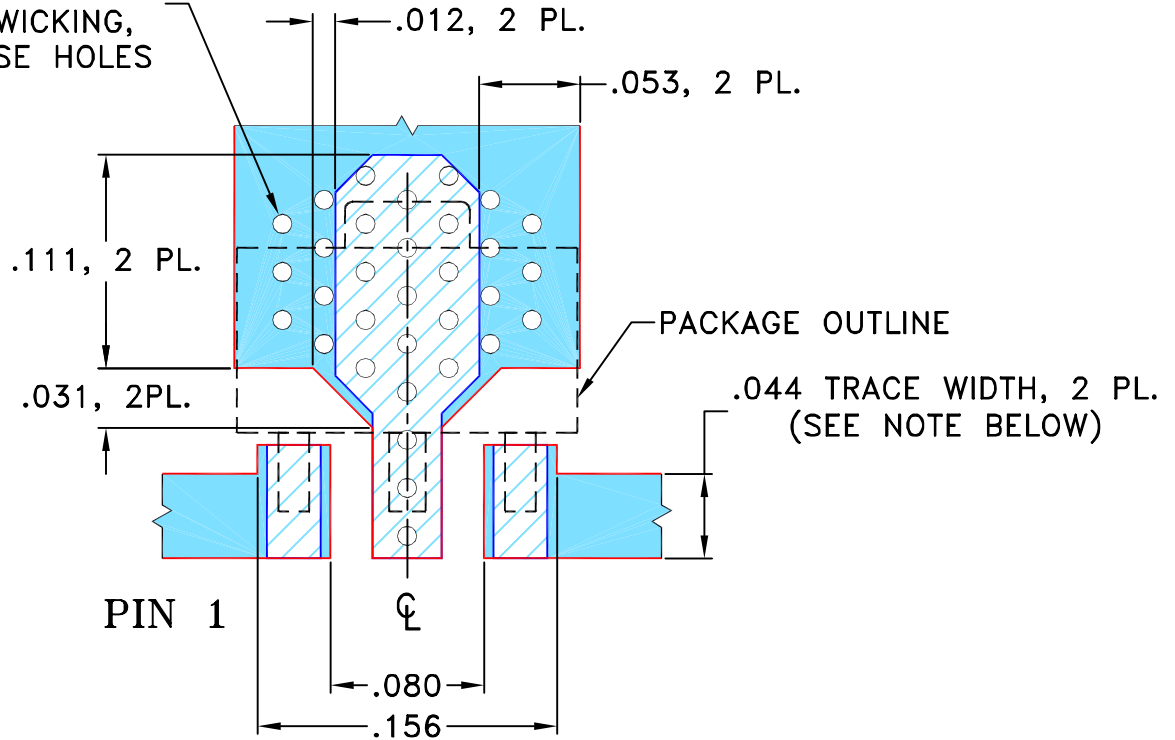

- NOTES: 1. TRACE WIDTH IS SHOWN FOR ROGERS R04350B WITH DIELECTRIC THICKNESS .020" \pm .0015"; COPPER: 1/2 OZ. EACH SIDE. FOR OTHER MATERIALS TRACE WIDTH MAY NEED TO BE MODIFIED.
2. BOTTOM SIDE OF THE PCB IS CONTINUOUS GROUND PLANE.



DENOTES PCB COPPER LAYOUT WITH SMOBC (SOLDER MASK OVER BARE COPPER)



DENOTES COPPER LAND PATTERN FREE OF SOLDER MASK

UNLESS OTHERWISE SPECIFIED

INITIALS

DATE

DIMENSIONS ARE IN INCHES

DRAWN

PW

06/01/12

TOLERANCES ON:

CHECKED

IL

07/10/12

2 PL DECIMALS \pm

APPROVED

DJ

07/10/12

3 PL DECIMALS \pm .005

ANGLES \pm

FRACTIONS \pm

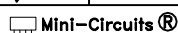

Mini-Circuits®

13 Neptune Avenue
Brooklyn NY 11235

PL, 04AM03, DF782, TB-678-105+

SIZE

CODE IDENT

DRAWING NO:

REV:

A

15542

98-PL-370

OR

FILE:

98PL370

SCALE:

10:1

SHEET:

1 OF 1

ASHEETA1.DWG REV:A DATE:01/12/95

THIS DOCUMENT AND ITS CONTENTS ARE THE PROPERTY OF MINI-CIRCUITS. EXCEPT FOR USE EXPRESSLY GRANTED, IN WRITING, TO ITS VENDORS, VENDEE AND THE UNITED STATES GOVERNMENT, MINI-CIRCUITS RESERVES ALL PROPRIETARY DESIGN, USE, MANUFACTURING AND REPRODUCTION RIGHTS THERETO. THESE CONTENTS SHALL NOT BE USED, DUPLICATED OR DISCLOSED TO ANY OUTSIDE PARTY, IN WHOLE OR IN PART, WITHOUT WRITTEN PERMISSION OF MINI-CIRCUITS.

Evaluation Board and Circuit

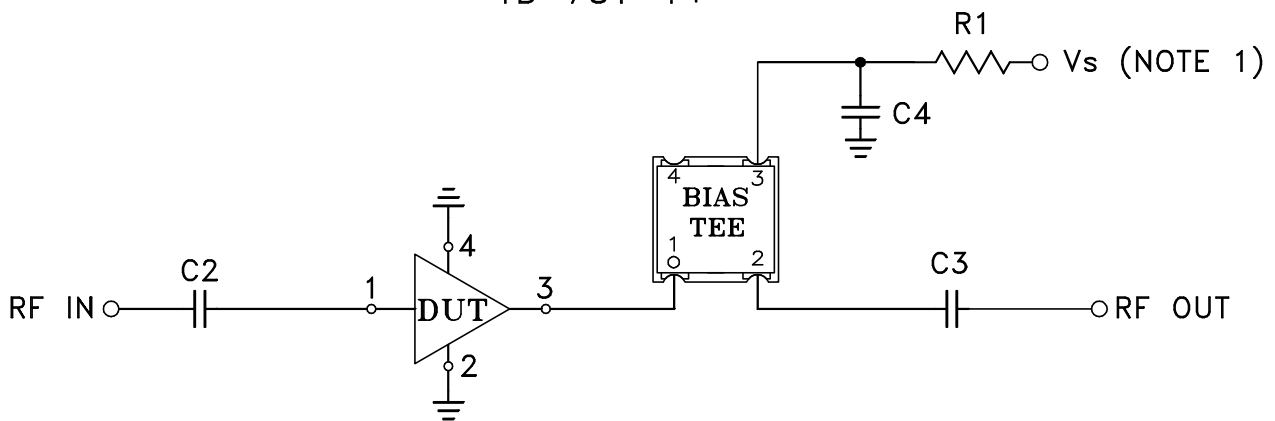
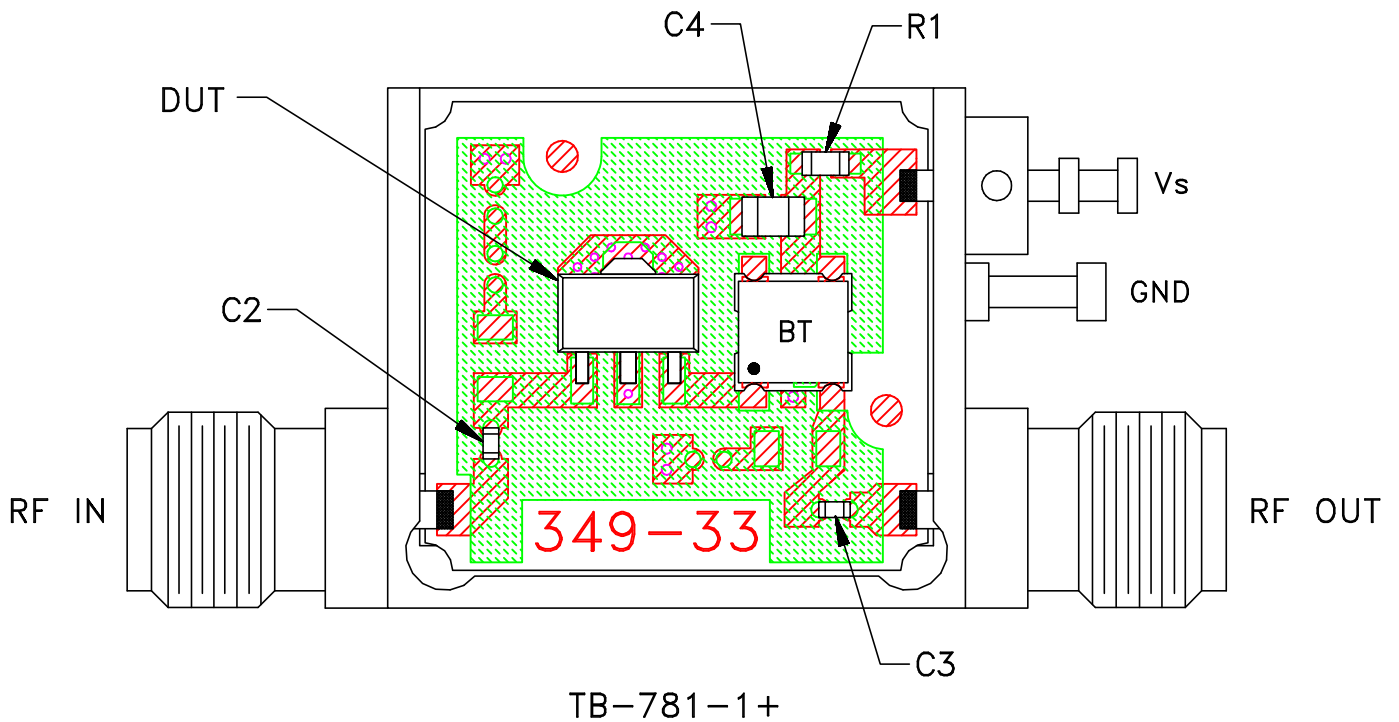

COMPONENT	VALUE	SIZE
DUT	GVA-93+	SOT-89
C1	NOT USED	
C2,C3	0.001 μ F	0402
C4	0.1 μ F	0805
R1	16.5 Ohm	0603
BIAS TEE	Mini-Circuits TCBT-14+	

NOTES:

1. Vs voltage: $+5 \pm 0.2$ V.
2. SMA Female connectors.
3. PCB material: Rogers R04350 or equivalent, dielectric constant=3.5, dielectric thickness=.020 inch.

Schematic Diagram

 **Mini-Circuits®**

All Mini-Circuits products are manufactured under exacting quality assurance and control standards, and are capable of meeting published specifications after being subjected to any or all of the following physical and environmental test.

Specification	Test/Inspection Condition	Reference/Spec
Operating Temperature	-40° to 85° C or -45° to 85° C or -55° to 105° C or -40° to 105° C or -40° to 95° C Ambient Environment	Individual Model Data Sheet
Storage Temperature	-55° to 100° C or -65° to 150° Ambient Environment	Individual Model Data Sheet
HTOL	1000 hours at 125°C	MIL-STD-883, Method 1005, Condition B
Thermal Shock	-55° to 100°C, 100 cycles	MIL-STD-202, Method 107, Condition A-3, except +100°C
Mechanical Shock	1.5Kg, 0.5 ms, 5 shock pulses, Y1 direction only	MIL-STD-883, Method 2002, Condition B, except Y1 direction only
Vibration (Variable Frequency)	50g peak	MIL-STD-883, Method 2007, Condition B
Autoclave	15 psig, 100% RH, 121°C, 96 hours	JESD22-A102, Condition C
HAST	130°C, 85% RH, 96 hours	JESD22-A110
Solderability	10X Magnification	J-STD-002, Para 4.2.5, Test S, 95% Coverage
Solder Reflow Heat	Sn-Pb Eutetic Process: 240°C peak Pb-Free Process: 260°C peak	J-STD-020, Table 4-1, 4-2 and 5-2; Figure 5-1
Moisture Sensitivity: Level 1	Bake at 125°C for 24 hours Soak at 85°C/85% RH for 168 hours, Reflow 3 cycles at 260°C peak	J-STD-020

All Mini-Circuits products are manufactured under exacting quality assurance and control standards, and are capable of meeting published specifications after being subjected to any or all of the following physical and environmental test.

Specification	Test/Inspection Condition	Reference/Spec
Marking Resistance to Solvents	Isopropyl alcohol + mineral spirits at 25°C; terpene defluxer at 25°C; distilled water + proylene glycol monomethyl ether + monoethanolamine at 63°C to 70°C	MIL-STD-202, Method 215