

Surface Mount

Monolithic Amplifier

DC-4 GHz

Product Features

- InGaP HBT microwave amplifier
- Miniature SOT-89 package
- Internally Matched to 50 Ohms
- Frequency range, DC to 4 GHz
- Output power, 15.7 dBm typ.
- Excellent package for heat dissipation, exposed metal bottom
- Low thermal resistance for high reliability
- Aqueous washable
- Protected by US Patent 6,943,629

Typical Applications

- Cellular
- PCS
- Communication receivers & transmitters

General Description

Gali₅F+ (RoHS compliant) is a wideband amplifier offering high dynamic range. It has repeatable performance from lot to lot, and is enclosed in a SOT-89 package. It uses patented Transient Protected Darlington configuration and is fabricated using InGaP HBT technology. Expected MTTF is 8,000 years at 85°C case temperature. Gali₅F+ is designed to be rugged for ESD and supply switch-on transients.

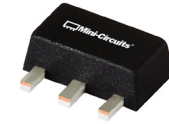

Generic photo used for illustration purposes only

Gali₅F+

CASE STYLE: DF782

+RoHS Compliant

The +Suffix identifies RoHS Compliance. See our web site for RoHS Compliance methodologies and qualifications

simplified schematic and pin description

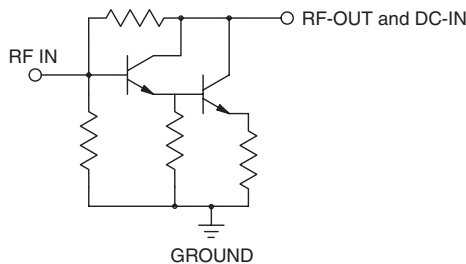

Function	Pin Number	Description
RF IN	1	RF input pin. This pin requires the use of an external DC blocking capacitor chosen for the frequency of operation.
RF-OUT and DC-IN	3	RF output and bias pin. DC voltage is present on this pin; therefore a DC blocking capacitor is necessary for proper operation. An RF choke is needed to feed DC bias without loss of RF signal due to the bias connection, as shown in "Recommended Application Circuit".
GND	2,4	Connections to ground. Use via holes as shown in "Suggested Layout for PCB Design" to reduce ground path inductance for best performance.

Notes

- Performance and quality attributes and conditions not expressly stated in this specification document are intended to be excluded and do not form a part of this specification document.
- Electrical specifications and performance data contained in this specification document are based on Mini-Circuit's applicable established test performance criteria and measurement instructions.
- The parts covered by this specification document are subject to Mini-Circuits standard limited warranty and terms and conditions (collectively, "Standard Terms"); Purchasers of this part are entitled to the rights and benefits contained therein. For a full statement of the Standard Terms and the exclusive rights and remedies thereunder, please visit Mini-Circuits' website at www.minicircuits.com/MCLStore/terms.jsp



Electrical Specifications at 25°C and 50mA, unless noted

Parameter		Min.	Typ.	Max.	Units
Frequency Range*		DC		4	GHz
Gain	f=0.1 GHz	—	20.4	—	dB
	f=1 GHz	—	19.3	—	
	f=2 GHz	15.5	17.4	—	
	f=3 GHz	—	16.0	—	
	f=4 GHz	—	14.8	—	
	f=6 GHz	—	15.1	—	
Input Return Loss	f= DC to 3 GHz		21		dB
	f= 3 to 4 GHz		21		
Output Return Loss	f= DC to 3 GHz		15.5		dB
	f= 3 to 4 GHz		15.5		
Output Power @ 1 dB compression	f=1 GHz	14.2	15.7	—	dBm
Output IP3	f=1 GHz		31.5		dBm
Noise Figure	f=1 GHz		3.5		dB
Recommended Device Operating Current			50		mA
Device Operating Voltage		3.9	4.3	4.9	V
Device Voltage Variation vs. Temperature at 50 mA			-3.2		mV/°C
Device Voltage Variation vs. Current at 25°C			4.5		mV/mA
Thermal Resistance, junction-to-case ¹			103		°C/W

*Guaranteed specification DC-4 GHz. Low frequency cut off determined by external coupling capacitors.

Absolute Maximum Ratings

Parameter	Ratings
Operating Temperature*	-45°C to 85°C
Storage Temperature	-65°C to 150°C
Operating Current	65mA
Input Power	13dBm

Note: Permanent damage may occur if any of these limits are exceeded.

These ratings are not intended for continuous normal operation.

¹Case is defined as ground leads.

*Based on typical case temperature rise 3°C above ambient.

Notes

A. Performance and quality attributes and conditions not expressly stated in this specification document are intended to be excluded and do not form a part of this specification document.

B. Electrical specifications and performance data contained in this specification document are based on Mini-Circuit's applicable established test performance criteria and measurement instructions.

C. The parts covered by this specification document are subject to Mini-Circuits standard limited warranty and terms and conditions (collectively, "Standard Terms"); Purchasers of this part are entitled to the rights and benefits contained therein. For a full statement of the Standard Terms and the exclusive rights and remedies thereunder, please visit Mini-Circuits' website at www.minicircuits.com/MCLStore/terms.jsp



Product Marking

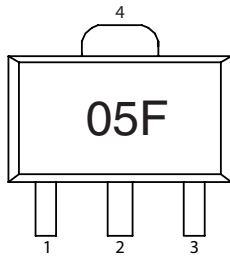

Markings in addition to model number designation may appear for internal quality control purposes.

Additional Detailed Technical Information

Additional information is available on our web site. To access this information enter the model number on our web site home page.

Performance data, graphs, s-parameter data set (.zip file)

Case Style: DF782

Plastic package, exposed paddle, lead finish: matte-tin

Tape & Reel: F55

7” reels with 20, 50, 100, 200, 500, 1K devices.

Suggested Layout for PCB Design: PL-019

Evaluation Board: TB-409-5F+

Environmental Ratings: ENV08T2

Recommended Application Circuit

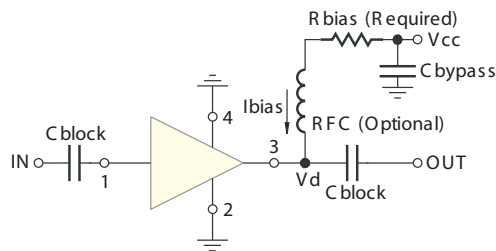

Test Board includes case, connectors, and components (in bold) soldered to PCB

R BIAS	
Vcc	“1%” Res. Values (ohms) for Optimum Biasing
7	52.3
8	71.5
9	90.9
10	110
11	130
12	150
13	169
14	191
15	210
16	232
17	249
18	274
19	294
20	316

Notes

- A. Performance and quality attributes and conditions not expressly stated in this specification document are intended to be excluded and do not form a part of this specification document.
- B. Electrical specifications and performance data contained in this specification document are based on Mini-Circuit's applicable established test performance criteria and measurement instructions.
- C. The parts covered by this specification document are subject to Mini-Circuits standard limited warranty and terms and conditions (collectively, "Standard Terms"); Purchasers of this part are entitled to the rights and benefits contained therein. For a full statement of the Standard Terms and the exclusive rights and remedies thereunder, please visit Mini-Circuits' website at www.minicircuits.com/MCLStore/terms.jsp



ESD Rating

Human Body Model (HBM): Class 1B (500v to < 1000v) in accordance with ANSI/ESD STM 5.1 - 2001

Machine Model (MM): Class M1 (< 100v) in accordance with ANSI/ESD STM 5.2 - 1999

MSL Rating

Moisture Sensitivity: MSL1 in accordance with IPC/JEDECJ-STD-020C

No.	Test Required	Condition	Standard	Quantity
1	Visual Inspection	Low Power Microscope Magnification 40x	MIP-IN-0003 (MCT spec)	45 units
2	Electrical Test	Room Temperature	SCD (MCL spec)	45 units
3	SAM Analysis	Less than 10% growth in term of delamination	J-Std-020C (Jedec Standard)	45 units
4	Moisture Sensitivity Level 1	Bake at 125°C for 24 hours Soak at 85°C/85%RH for 168 hours Reflow 3 cycles at 260°C peak	J-Std-020C (Jedec Standard)	45 units

MSL Test Flow Chart

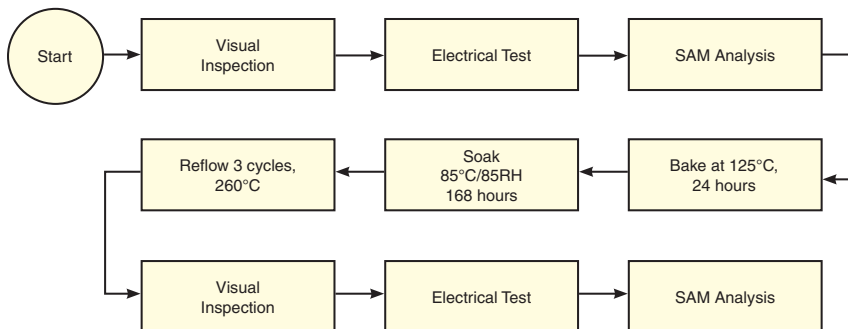

Notes

- A. Performance and quality attributes and conditions not expressly stated in this specification document are intended to be excluded and do not form a part of this specification document.
- B. Electrical specifications and performance data contained in this specification document are based on Mini-Circuit's applicable established test performance criteria and measurement instructions.
- C. The parts covered by this specification document are subject to Mini-Circuits standard limited warranty and terms and conditions (collectively, "Standard Terms"); Purchasers of this part are entitled to the rights and benefits contained therein. For a full statement of the Standard Terms and the exclusive rights and remedies thereunder, please visit Mini-Circuits' website at www.minicircuits.com/MCLStore/terms.jsp



Typical Performance Data

NOTE: Use PDF Bookmarks to view DATA at required conditions or to view GRAPHS.

Definitions:

Input Return Loss = -S11 (dB)

Gain(Power Gain) = S21 (dB)

Reverse Isolation = -S12 (dB)

Output Return Loss = -S22 (dB)

TEST CONDITIONS: Icc = 50mA, Vd =4.35V @Temperature = +25degC

FREQ	Gain	Isolation	Input Return Loss	Output Return Loss	Stability		FREQ	IP3 Output	1dB Comp. Output	Noise Figure
(MHz)	(dB)	(dB)	(dB)	(dB)	K	Delta	(MHz)	(dBm)	(dBm)	(dB)
50	21.32	24.07	42.00	28.01	1.05	0.73	50	30.63	16.57	3.27
100	21.30	24.08	46.95	27.45	1.05	0.73	100	30.92	16.55	3.33
200	21.25	24.12	50.41	25.81	1.05	0.72	200	30.92	16.44	3.31
300	21.12	24.05	54.15	24.51	1.06	0.71	300	30.81	16.24	3.49
400	21.02	24.07	53.29	23.10	1.06	0.70	400	30.44	16.32	3.42
500	20.89	24.06	54.30	21.75	1.06	0.69	500	30.37	16.30	3.39
600	20.78	24.08	62.71	20.55	1.07	0.68	600	30.38	16.31	3.45
700	20.61	24.07	52.65	19.65	1.07	0.67	700	30.65	16.24	3.42
800	20.45	24.06	46.07	18.85	1.08	0.66	800	30.80	16.37	3.36
900	20.28	24.07	42.55	18.21	1.08	0.65	900	30.76	15.97	3.43
1000	20.11	24.06	40.84	17.57	1.09	0.63	1000	30.55	16.02	3.37
1200	19.72	24.03	34.52	16.56	1.11	0.61	1100	30.27	16.08	3.38
1400	19.35	24.04	30.45	15.73	1.12	0.58	1200	30.06	16.11	3.40
1600	18.95	24.02	27.69	15.16	1.14	0.55	1300	29.73	15.81	3.40
1800	18.59	24.00	25.19	14.53	1.15	0.53	1400	29.32	15.75	3.41
2000	18.20	23.95	22.86	14.12	1.17	0.50	1500	29.16	15.58	3.40
2200	17.80	23.92	20.85	13.87	1.19	0.48	1600	29.31	15.42	3.37
2400	17.44	23.87	19.37	13.52	1.21	0.46	1700	29.58	15.40	3.37
2600	17.07	23.91	18.21	13.45	1.24	0.43	1800	29.13	15.27	3.36
2800	16.74	23.80	16.97	13.10	1.24	0.41	1900	28.80	15.15	3.45
3000	16.43	23.69	15.97	12.86	1.25	0.40	2000	28.55	15.08	3.47
3200	16.11	23.69	15.17	12.87	1.27	0.38	2100	28.15	14.94	3.49
3400	15.87	23.58	14.42	12.70	1.28	0.37	2200	27.74	14.76	3.40
3600	15.60	23.54	14.08	12.74	1.29	0.36	2300	27.51	14.50	3.50
3800	15.36	23.43	13.68	12.75	1.30	0.35	2400	27.23	14.14	3.51
4000	15.17	23.45	13.42	12.88	1.33	0.35	2500	27.02	13.77	3.47
4200	15.00	23.21	13.35	12.71	1.31	0.35	2600	26.68	13.61	3.45
4500	14.71	23.10	13.74	12.84	1.34	0.34	2700	26.48	13.50	3.51
5000	14.40	22.86	14.46	12.39	1.35	0.33	2800	26.39	13.26	3.46
6000	13.85	22.57	16.14	10.91	1.37	0.33	2900	26.07	13.22	3.48
7000	12.46	23.11	12.79	7.79	1.50	0.32	3000	25.87	13.09	3.61
8000	9.39	22.22	10.39	7.55	1.81	0.31	3100	25.47	12.84	3.56
9000	5.81	21.08	8.02	7.12	2.14	0.30	3200	25.29	12.64	3.57
10000	2.63	19.57	6.78	6.87	2.32	0.28	3300	24.97	12.66	3.65
11000	1.15	15.16	7.29	7.26	1.71	0.23	3400	24.74	12.40	3.69
12000	0.31	11.61	9.10	8.53	1.44	0.22	3500	24.60	12.07	3.68
13000	-0.17	7.75	11.89	10.94	1.21	0.34	3600	24.41	11.83	3.68
14000	-0.52	4.40	12.76	12.47	1.06	0.56	3700	24.28	11.49	3.71
15000	-2.94	4.68	5.51	5.29	1.05	0.67	3800	23.98	11.30	3.77
16000	-5.00	5.63	4.08	3.94	1.12	0.67	4000	23.45	11.01	3.59

REV. X1
GALI-5F+
120123

Page 1 of 11



IF/RF MICROWAVE COMPONENTS • ISO 9001 ISO 14001 AS 9100 CERTIFIED • RoHS compliant
P.O. Box 350166, Brooklyn, New York 11235-0003 (718) 934-4500 Fax (718) 332-4661



The Design Engineers Search Engine finds the model you need, Instantly • For detailed performance specs & shopping online see



Typical Performance Data

Definitions:

Input Return Loss = -S11 (dB)

Gain(Power Gain) = S21 (dB)

Reverse Isolation = -S12 (dB)

Output Return Loss = -S22 (dB)

TEST CONDITIONS: Icc = 40mA, Vd =4.30V @Temperature = +25degC

FREQ	Gain	Isolation	Input Return Loss	Output Return Loss	Stability		FREQ	IP3 Output	1dB Comp. Output	Noise Figure
					K	Delta				
(MHz)	(dB)	(dB)	(dB)	(dB)	K	Delta	(MHz)	(dBm)	(dBm)	(dB)
50	21.06	23.77	29.35	39.61	1.05	0.73	50	27.13	13.99	3.21
100	20.99	23.82	29.42	35.72	1.05	0.72	100	27.43	13.95	3.29
200	20.95	23.82	30.58	30.75	1.05	0.72	200	27.43	13.85	3.27
300	20.84	23.78	30.12	27.31	1.06	0.71	300	27.31	13.75	3.43
400	20.74	23.80	31.74	24.99	1.06	0.70	400	27.00	13.80	3.38
500	20.58	23.80	31.49	23.18	1.06	0.69	500	27.05	13.74	3.34
600	20.46	23.83	32.13	21.69	1.07	0.68	600	27.13	13.78	3.43
700	20.33	23.83	30.17	20.54	1.07	0.67	700	27.47	13.75	3.38
800	20.15	23.77	30.84	19.60	1.08	0.66	800	27.74	13.84	3.29
900	20.00	23.81	30.39	18.79	1.08	0.64	900	27.76	13.66	3.37
1000	19.83	23.79	28.94	18.09	1.09	0.63	1000	27.63	13.63	3.33
1200	19.50	23.76	27.25	16.95	1.10	0.61	1100	27.38	13.72	3.31
1400	19.12	23.79	26.03	15.99	1.12	0.58	1200	27.29	13.63	3.38
1600	18.73	23.74	24.32	15.38	1.13	0.55	1300	27.14	13.39	3.36
1800	18.35	23.73	22.59	14.70	1.15	0.53	1400	26.89	13.33	3.35
2000	18.00	23.66	20.58	14.23	1.16	0.50	1500	26.84	13.25	3.38
2200	17.61	23.67	19.34	13.94	1.18	0.48	1600	27.02	13.16	3.30
2400	17.24	23.63	18.07	13.56	1.20	0.46	1700	27.46	13.24	3.31
2600	16.89	23.68	16.89	13.48	1.22	0.43	1800	27.19	13.10	3.31
2800	16.58	23.55	15.99	13.09	1.23	0.42	1900	26.94	13.22	3.40
3000	16.26	23.50	15.15	12.85	1.24	0.40	2000	26.83	13.28	3.41
3200	15.97	23.47	14.39	12.84	1.26	0.38	2100	26.52	13.29	3.42
3400	15.70	23.40	13.75	12.66	1.27	0.37	2200	26.28	13.01	3.35
3600	15.44	23.35	13.30	12.70	1.28	0.36	2300	26.18	12.71	3.42
3800	15.21	23.26	12.98	12.71	1.29	0.35	2400	26.03	12.45	3.42
4000	14.99	23.27	12.84	12.86	1.32	0.34	2500	25.85	12.25	3.41
4200	14.83	23.08	12.67	12.71	1.31	0.34	2600	25.53	12.32	3.40
4500	14.54	22.93	13.21	12.90	1.33	0.34	2700	25.33	12.39	3.45
5000	14.25	22.70	13.79	12.56	1.34	0.33	2800	25.25	12.22	3.40
6000	13.65	22.44	15.43	11.29	1.38	0.33	2900	24.98	12.18	3.40
7000	12.27	22.97	12.44	8.15	1.52	0.31	3000	24.86	12.11	3.55
8000	9.22	22.12	10.23	7.87	1.83	0.30	3100	24.57	11.94	3.54
9000	5.64	21.01	7.96	7.45	2.18	0.29	3200	24.39	11.84	3.51
10000	2.51	19.58	6.75	7.13	2.37	0.27	3300	24.05	11.81	3.60
11000	1.01	15.21	7.24	7.46	1.75	0.22	3400	23.90	11.56	3.64
12000	0.20	11.68	9.01	8.67	1.47	0.21	3500	23.72	11.29	3.62
13000	-0.27	7.83	11.77	10.97	1.22	0.33	3600	23.60	11.06	3.61
14000	-0.58	4.43	12.67	12.59	1.07	0.56	3700	23.44	10.78	3.65
15000	-3.00	4.70	5.50	5.35	1.06	0.67	3800	23.14	10.61	3.70
16000	-5.03	5.63	4.09	3.96	1.12	0.67	4000	22.64	10.27	3.51

REV. X1
GALI-5F+
120123
Page 2 of 11



IF/RF MICROWAVE COMPONENTS • ISO 9001 ISO 14001 AS 9100 CERTIFIED • RoHS compliant
P.O. Box 350166, Brooklyn, New York 11235-0003 (718) 934-4500 Fax (718) 332-4661



The Design Engineers Search Engine finds the model you need, Instantly • For detailed performance specs & shopping online see



Typical Performance Data

Definitions:

Input Return Loss = -S11 (dB)

Gain(Power Gain) = S21 (dB)

Reverse Isolation = -S12 (dB)

Output Return Loss = -S22 (dB)

TEST CONDITIONS: Icc = 60mA, Vd =4.39V @Temperature = +25degC

FREQ	Gain	Isolation	Input Return Loss	Output Return Loss	Stability		FREQ	IP3 Output	1dB Comp. Output	Noise Figure
					K	Delta				
(MHz)	(dB)	(dB)	(dB)	(dB)	K	Delta	(MHz)	(dBm)	(dBm)	(dB)
50	21.52	24.40	38.16	24.53	1.05	0.72	50	33.25	18.06	3.30
100	21.49	24.24	37.53	24.19	1.05	0.73	100	33.53	18.10	3.37
200	21.42	24.26	35.26	23.45	1.05	0.72	200	33.54	18.05	3.37
300	21.29	24.27	35.61	22.61	1.06	0.71	300	33.40	17.99	3.54
400	21.19	24.27	35.23	21.61	1.06	0.70	400	32.95	17.93	3.50
500	21.06	24.29	36.49	20.59	1.06	0.69	500	32.72	17.94	3.41
600	20.94	24.26	36.76	19.65	1.07	0.68	600	32.65	17.91	3.49
700	20.77	24.26	37.58	18.87	1.07	0.67	700	32.75	17.90	3.48
800	20.61	24.25	39.42	18.24	1.08	0.66	800	32.77	17.90	3.42
900	20.45	24.22	41.54	17.63	1.08	0.65	900	32.62	17.63	3.48
1000	20.26	24.23	45.17	17.09	1.09	0.63	1000	32.29	17.60	3.41
1200	19.87	24.23	46.31	16.21	1.11	0.61	1100	31.99	17.61	3.44
1400	19.50	24.19	36.12	15.43	1.12	0.58	1200	31.67	17.57	3.48
1600	19.08	24.21	31.11	14.95	1.14	0.55	1300	31.21	17.41	3.43
1800	18.71	24.15	27.29	14.36	1.16	0.53	1400	30.72	17.24	3.45
2000	18.33	24.10	24.55	14.00	1.18	0.50	1500	30.46	17.15	3.45
2200	17.92	24.07	22.35	13.77	1.20	0.48	1600	30.52	16.89	3.43
2400	17.57	23.99	20.45	13.44	1.21	0.46	1700	30.69	16.75	3.39
2600	17.19	24.05	19.17	13.37	1.24	0.43	1800	30.17	16.47	3.41
2800	16.86	23.93	17.91	13.06	1.25	0.42	1900	29.79	16.24	3.52
3000	16.56	23.81	16.72	12.82	1.25	0.40	2000	29.49	15.97	3.53
3200	16.24	23.82	15.90	12.84	1.28	0.38	2100	29.05	15.79	3.52
3400	15.99	23.71	15.00	12.68	1.28	0.37	2200	28.57	15.61	3.47
3600	15.72	23.64	14.59	12.71	1.30	0.36	2300	28.25	15.37	3.56
3800	15.47	23.57	14.21	12.72	1.31	0.35	2400	27.94	15.03	3.55
4000	15.28	23.55	13.83	12.84	1.33	0.35	2500	27.70	14.56	3.53
4200	15.10	23.34	13.75	12.66	1.32	0.35	2600	27.41	14.29	3.53
4500	14.84	23.19	14.20	12.73	1.34	0.34	2700	27.20	14.18	3.59
5000	14.52	22.94	14.96	12.20	1.34	0.34	2800	27.10	13.91	3.52
6000	13.99	22.63	16.70	10.60	1.36	0.34	2900	26.79	13.81	3.57
7000	12.63	23.18	13.02	7.50	1.48	0.32	3000	26.54	13.65	3.68
8000	9.54	22.30	10.48	7.26	1.78	0.31	3100	26.13	13.39	3.63
9000	5.93	21.12	8.05	6.91	2.11	0.31	3200	25.93	13.21	3.63
10000	2.75	19.59	6.81	6.70	2.29	0.28	3300	25.63	13.19	3.72
11000	1.22	15.14	7.33	7.13	1.68	0.24	3400	25.35	12.99	3.78
12000	0.40	11.58	9.18	8.43	1.43	0.23	3500	25.27	12.64	3.73
13000	-0.09	7.70	11.99	10.90	1.19	0.34	3600	25.05	12.40	3.79
14000	-0.47	4.37	12.83	12.35	1.06	0.57	3700	24.93	12.07	3.78
15000	-2.90	4.67	5.52	5.25	1.05	0.67	3800	24.62	11.85	3.84
16000	-4.98	5.63	4.09	3.92	1.12	0.67	4000	24.08	11.51	3.67

REV. X1
GALI-5F+
120123

Page 3 of 11



IF/RF MICROWAVE COMPONENTS • ISO 9001 ISO 14001 AS 9100 CERTIFIED • RoHS compliant

P.O. Box 350166, Brooklyn, New York 11235-0003 (718) 934-4500 Fax (718) 332-4661



The Design Engineers Search Engine finds the model you need, Instantly • For detailed performance specs & shopping online see



Typical Performance Data

Definitions:

Input Return Loss = -S11 (dB)

Gain(Power Gain) = S21 (dB)

Reverse Isolation = -S12 (dB)

Output Return Loss = -S22 (dB)

TEST CONDITIONS: Icc = 50mA, Vd =4.58V @Temperature = -45degC

FREQ	Gain	Isolation	Input Return Loss	Output Return Loss	Stability		FREQ	IP3 Output	1dB Comp. Output	Noise Figure
					K	Delta				
(MHz)	(dB)	(dB)	(dB)	(dB)	K	Delta	(MHz)	(dBm)	(dBm)	(dB)
50	21.43	24.14	40.53	27.47	1.05	0.73	50	31.15	16.53	2.85
100	21.42	24.12	38.89	29.26	1.05	0.73	100	31.42	16.54	2.89
200	21.33	24.14	35.10	28.57	1.05	0.72	200	31.38	16.31	2.90
300	21.24	24.09	42.52	24.89	1.05	0.72	300	31.37	16.25	3.01
400	21.14	24.11	47.60	22.68	1.06	0.71	400	31.13	16.28	2.99
500	21.04	24.11	44.16	21.38	1.06	0.70	500	31.11	16.24	2.91
600	20.90	24.14	45.52	20.35	1.06	0.69	600	31.15	16.26	2.95
700	20.76	24.10	45.76	19.41	1.07	0.68	700	31.42	16.22	2.93
800	20.60	24.08	58.09	18.76	1.07	0.67	800	31.62	16.28	2.89
900	20.44	24.09	46.33	18.28	1.08	0.66	900	31.62	15.98	2.93
1000	20.27	24.09	45.31	17.70	1.08	0.64	1000	31.44	16.05	2.87
1200	19.90	24.04	38.94	16.56	1.10	0.62	1100	31.20	16.10	2.90
1400	19.55	24.03	34.17	15.67	1.11	0.59	1200	31.05	16.15	2.92
1600	19.13	24.04	29.53	15.16	1.13	0.56	1300	30.78	15.97	2.91
1800	18.79	24.01	26.96	14.52	1.14	0.54	1400	30.41	15.77	2.90
2000	18.40	23.97	24.43	14.20	1.16	0.52	1500	30.30	15.67	2.91
2200	18.02	23.93	22.80	13.78	1.18	0.49	1600	30.43	15.53	2.83
2400	17.68	23.88	20.80	13.49	1.19	0.47	1700	30.76	15.56	2.82
2600	17.28	23.98	19.22	13.56	1.23	0.44	1800	30.42	15.45	2.82
2800	16.99	23.79	17.83	13.06	1.22	0.43	1900	30.14	15.45	2.92
3000	16.70	23.71	16.78	12.73	1.23	0.42	2000	29.99	15.46	2.92
3200	16.40	23.72	15.88	12.75	1.25	0.40	2100	29.64	15.41	2.92
3400	16.17	23.60	15.43	12.56	1.26	0.39	2200	29.28	15.24	2.88
3600	15.94	23.49	14.84	12.45	1.26	0.38	2300	29.05	14.94	2.95
3800	15.70	23.37	14.61	12.43	1.27	0.37	2400	28.79	14.66	2.96
4000	15.45	23.51	14.42	12.83	1.32	0.36	2500	28.58	14.35	2.92
4200	15.35	23.27	13.94	12.38	1.28	0.36	2600	28.27	14.30	2.96
4500	15.07	23.16	14.41	12.54	1.31	0.35	2700	28.07	14.22	2.95
5000	14.82	22.94	14.58	12.13	1.31	0.35	2800	27.96	13.96	2.90
6000	14.41	22.53	16.82	10.34	1.29	0.36	2900	27.65	13.89	2.95
7000	13.29	22.95	12.87	7.01	1.33	0.36	3000	27.47	13.77	3.03
8000	10.57	22.12	10.79	7.09	1.58	0.34	3100	27.07	13.54	3.03
9000	6.97	21.06	8.15	6.26	1.84	0.34	3200	26.91	13.42	3.02
10000	3.49	19.47	6.34	6.17	1.97	0.31	3300	26.64	13.38	3.09
11000	2.06	15.16	7.09	6.75	1.49	0.26	3400	26.29	13.14	3.13
12000	1.28	11.52	9.26	8.01	1.29	0.26	3500	26.30	12.89	3.10
13000	0.58	7.79	10.47	10.16	1.09	0.37	3600	26.05	12.64	3.10
14000	0.25	4.08	13.72	11.87	0.98	0.61	3700	25.96	12.30	3.09
15000	-2.09	4.07	5.01	4.87	0.97	0.77	3800	25.60	12.13	3.16
16000	-5.33	6.08	3.00	2.74	1.03	0.76	4000	25.08	11.82	3.02

REV. X1
GALI-5F+
120123
Page 4 of 11



IF/RF MICROWAVE COMPONENTS • ISO 9001 ISO 14001 AS 9100 CERTIFIED • RoHS compliant
P.O. Box 350166, Brooklyn, New York 11235-0003 (718) 934-4500 Fax (718) 332-4661



The Design Engineers Search Engine finds the model you need, Instantly • For detailed performance specs & shopping online see



Typical Performance Data

Definitions:

Input Return Loss = -S11 (dB)

Gain(Power Gain) = S21 (dB)

Reverse Isolation = -S12 (dB)

Output Return Loss = -S22 (dB)

TEST CONDITIONS: Icc = 40mA, Vd =4.54V @Temperature = -45degC

FREQ	Gain	Isolation	Input Return Loss	Output Return Loss	Stability		FREQ	IP3 Output	1dB Comp. Output	Noise Figure
					K	Delta				
(MHz)	(dB)	(dB)	(dB)	(dB)	K	Delta	(MHz)	(dBm)	(dBm)	(dB)
50	21.14	23.95	30.16	35.59	1.05	0.72	50	27.43	13.95	2.81
100	21.14	23.90	28.14	37.93	1.05	0.73	100	27.69	13.86	2.85
200	21.06	23.86	27.91	32.58	1.05	0.72	200	27.62	13.74	2.88
300	20.98	23.85	29.96	27.70	1.05	0.72	300	27.63	13.66	2.99
400	20.89	23.92	34.84	24.54	1.06	0.70	400	27.45	13.67	2.94
500	20.80	23.88	34.95	22.91	1.06	0.70	500	27.53	13.63	2.88
600	20.67	23.87	35.65	21.35	1.06	0.69	600	27.62	13.69	2.92
700	20.51	23.84	33.44	20.34	1.07	0.68	700	27.96	13.72	2.89
800	20.39	23.85	33.15	19.50	1.07	0.67	800	28.27	13.79	2.85
900	20.22	23.88	32.15	18.87	1.08	0.65	900	28.33	13.68	2.89
1000	20.05	23.81	30.43	18.24	1.08	0.65	1000	28.20	13.64	2.85
1200	19.69	23.83	29.95	17.05	1.10	0.62	1100	27.98	13.64	2.86
1400	19.34	23.83	28.26	15.98	1.11	0.59	1200	27.92	13.61	2.87
1600	18.96	23.82	25.97	15.39	1.12	0.56	1300	27.83	13.36	2.87
1800	18.61	23.76	24.11	14.67	1.14	0.54	1400	27.60	13.31	2.89
2000	18.22	23.72	22.27	14.33	1.15	0.52	1500	27.59	13.24	2.88
2200	17.86	23.73	21.21	13.88	1.17	0.49	1600	27.74	13.07	2.81
2400	17.52	23.68	19.44	13.57	1.19	0.47	1700	28.22	13.21	2.81
2600	17.11	23.75	18.04	13.60	1.22	0.44	1800	28.05	13.19	2.80
2800	16.82	23.64	16.90	13.09	1.22	0.43	1900	27.89	13.32	2.90
3000	16.54	23.54	15.91	12.75	1.22	0.41	2000	27.86	13.43	2.88
3200	16.24	23.55	15.15	12.74	1.25	0.40	2100	27.66	13.43	2.88
3400	16.02	23.45	14.69	12.54	1.25	0.39	2200	27.48	13.21	2.85
3600	15.77	23.31	14.09	12.43	1.25	0.38	2300	27.44	12.92	2.92
3800	15.55	23.21	13.92	12.43	1.26	0.37	2400	27.32	12.66	2.93
4000	15.31	23.34	13.82	12.83	1.31	0.36	2500	27.18	12.58	2.88
4200	15.21	23.09	13.33	12.42	1.27	0.36	2600	26.99	12.71	2.88
4500	14.92	23.01	13.86	12.60	1.30	0.35	2700	26.82	12.85	2.92
5000	14.67	22.80	14.02	12.29	1.30	0.35	2800	26.75	12.78	2.85
6000	14.25	22.43	16.16	10.63	1.30	0.35	2900	26.50	12.69	2.90
7000	13.11	22.80	12.58	7.33	1.34	0.35	3000	26.37	12.68	2.96
8000	10.38	22.00	10.63	7.42	1.61	0.33	3100	26.03	12.58	2.94
9000	6.83	20.98	8.09	6.54	1.87	0.33	3200	25.94	12.48	2.96
10000	3.37	19.49	6.30	6.39	2.01	0.30	3300	25.70	12.43	3.02
11000	1.94	15.22	7.03	6.93	1.52	0.24	3400	25.40	12.28	3.05
12000	1.17	11.59	9.19	8.15	1.31	0.25	3500	25.39	12.05	3.06
13000	0.49	7.86	10.35	10.24	1.10	0.36	3600	25.15	11.91	3.03
14000	0.18	4.17	13.57	11.97	0.99	0.60	3700	25.02	11.61	3.05
15000	-2.15	4.11	5.00	4.92	0.98	0.77	3800	24.69	11.46	3.08
16000	-5.38	6.11	2.99	2.75	1.03	0.76	4000	24.23	11.15	2.95

REV. X1

GALI-5F+

120123

Page 5 of 11



IF/RF MICROWAVE COMPONENTS • ISO 9001 ISO 14001 AS 9100 CERTIFIED • RoHS compliant

P.O. Box 350166, Brooklyn, New York 11235-0003 (718) 934-4500 Fax (718) 332-4661



The Design Engineers Search Engine finds the model you need, Instantly • For detailed performance specs & shopping online see



Typical Performance Data

Definitions:

Input Return Loss = -S11 (dB)

Gain(Power Gain) = S21 (dB)

Reverse Isolation = -S12 (dB)

Output Return Loss = -S22 (dB)

TEST CONDITIONS: Icc = 60mA, Vd =4.62V @Temperature = -45degC

FREQ	Gain	Isolation	Input Return Loss	Output Return Loss	Stability		FREQ	IP3 Output	1dB Comp. Output	Noise Figure
					K	Delta				
(MHz)	(dB)	(dB)	(dB)	(dB)	K	Delta	(MHz)	(dBm)	(dBm)	(dB)
50	21.61	24.26	41.75	25.02	1.05	0.74	50	33.94	18.28	2.90
100	21.56	24.32	50.89	25.82	1.05	0.73	100	34.20	18.30	2.91
200	21.49	24.32	49.89	25.44	1.05	0.72	200	34.18	18.21	2.92
300	21.42	24.25	38.83	23.25	1.05	0.72	300	34.15	18.13	3.06
400	21.30	24.27	34.57	21.43	1.06	0.71	400	33.82	18.08	2.99
500	21.19	24.24	33.93	20.42	1.06	0.71	500	33.66	18.12	2.94
600	21.03	24.26	34.90	19.38	1.06	0.69	600	33.59	18.09	3.01
700	20.89	24.25	35.15	18.69	1.07	0.68	700	33.72	18.08	2.99
800	20.75	24.23	36.91	18.22	1.07	0.67	800	33.77	18.08	2.93
900	20.57	24.24	41.51	17.78	1.08	0.66	900	33.70	17.81	2.97
1000	20.40	24.25	43.38	17.24	1.09	0.64	1000	33.41	17.80	2.90
1200	20.04	24.19	43.48	16.27	1.10	0.62	1100	33.15	17.85	3.01
1400	19.66	24.17	40.67	15.43	1.11	0.59	1200	32.93	17.85	2.96
1600	19.27	24.18	33.54	14.97	1.13	0.56	1300	32.48	17.65	2.92
1800	18.89	24.12	29.25	14.34	1.15	0.54	1400	32.05	17.52	2.92
2000	18.52	24.08	26.38	14.06	1.16	0.52	1500	31.81	17.39	2.95
2200	18.14	24.06	24.43	13.68	1.18	0.49	1600	31.91	17.20	2.89
2400	17.77	24.01	21.85	13.41	1.20	0.47	1700	32.10	17.15	2.89
2600	17.38	24.10	20.20	13.50	1.24	0.44	1800	31.64	16.93	2.88
2800	17.10	23.92	18.67	13.02	1.23	0.43	1900	31.32	16.81	2.98
3000	16.80	23.82	17.42	12.70	1.24	0.42	2000	31.09	16.59	2.99
3200	16.51	23.83	16.54	12.73	1.26	0.40	2100	30.67	16.42	2.97
3400	16.27	23.71	15.96	12.54	1.26	0.39	2200	30.22	16.23	2.91
3600	16.03	23.58	15.33	12.42	1.26	0.38	2300	29.90	16.03	2.97
3800	15.81	23.49	15.16	12.40	1.27	0.38	2400	29.58	15.69	2.99
4000	15.54	23.62	14.85	12.77	1.32	0.36	2500	29.31	15.25	2.97
4200	15.47	23.38	14.41	12.34	1.29	0.36	2600	29.02	15.01	2.99
4500	15.16	23.24	14.82	12.43	1.31	0.36	2700	28.82	14.87	3.00
5000	14.93	23.02	15.04	11.97	1.31	0.35	2800	28.70	14.62	2.95
6000	14.52	22.61	17.32	10.09	1.28	0.36	2900	28.40	14.47	2.98
7000	13.45	23.02	13.10	6.74	1.31	0.36	3000	28.21	14.42	3.09
8000	10.73	22.21	10.89	6.82	1.56	0.35	3100	27.75	14.13	3.06
9000	7.10	21.09	8.21	6.11	1.81	0.35	3200	27.57	13.99	3.06
10000	3.60	19.50	6.33	6.01	1.93	0.32	3300	27.28	13.96	3.13
11000	2.15	15.12	7.11	6.62	1.46	0.26	3400	26.94	13.69	3.17
12000	1.39	11.46	9.37	7.91	1.27	0.27	3500	26.96	13.42	3.15
13000	0.65	7.75	10.55	10.09	1.08	0.37	3600	26.74	13.14	3.13
14000	0.31	4.03	13.80	11.84	0.98	0.62	3700	26.65	12.84	3.17
15000	-2.05	4.04	5.02	4.79	0.97	0.78	3800	26.29	12.66	3.20
16000	-5.32	6.08	3.00	2.70	1.02	0.77	4000	25.72	12.41	3.07

REV. X1
GALI-5F+
120123
Page 6 of 11



IF/RF MICROWAVE COMPONENTS • ISO 9001 ISO 14001 AS 9100 CERTIFIED • RoHS compliant
P.O. Box 350166, Brooklyn, New York 11235-0003 (718) 934-4500 Fax (718) 332-4661



The Design Engineers Search Engine finds the model you need, Instantly • For detailed performance specs & shopping online see



Typical Performance Data

Definitions:

Input Return Loss = -S11 (dB)

Gain(Power Gain) = S21 (dB)

Reverse Isolation = -S12 (dB)

Output Return Loss = -S22 (dB)

TEST CONDITIONS: Icc = 50mA, Vd =4.16V @Temperature = +85degC

FREQ	Gain	Isolation	Input Return Loss	Output Return Loss	Stability		FREQ	IP3 Output	1dB Comp. Output	Noise Figure
					K	Delta				
(MHz)	(dB)	(dB)	(dB)	(dB)	K	Delta	(MHz)	(dBm)	(dBm)	(dB)
50	21.18	24.11	39.00	29.19	1.06	0.71	50	30.28	16.52	3.68
100	21.17	23.89	47.21	27.93	1.05	0.73	100	30.61	16.47	3.71
200	21.10	23.99	41.61	24.93	1.05	0.72	200	30.69	16.37	3.75
300	20.96	23.97	51.23	23.74	1.06	0.71	300	30.51	16.28	3.89
400	20.86	24.05	45.40	23.13	1.06	0.69	400	30.06	16.27	3.85
500	20.73	24.00	43.41	21.85	1.07	0.69	500	29.92	16.26	3.81
600	20.61	23.99	41.29	20.84	1.07	0.68	600	29.90	16.22	3.91
700	20.44	23.96	38.70	19.84	1.07	0.67	700	30.09	16.22	3.86
800	20.27	23.99	37.08	18.90	1.08	0.65	800	30.20	16.25	3.81
900	20.10	24.01	33.82	18.42	1.09	0.64	900	30.11	15.93	3.89
1000	19.92	23.95	32.51	17.74	1.09	0.63	1000	29.83	15.96	3.83
1200	19.51	23.97	29.35	16.67	1.11	0.60	1100	29.53	15.94	3.83
1400	19.14	23.97	27.38	15.84	1.13	0.57	1200	29.28	15.95	3.89
1600	18.73	23.96	25.39	15.22	1.15	0.54	1300	28.92	15.75	3.87
1800	18.36	23.91	23.35	14.55	1.16	0.52	1400	28.49	15.57	3.88
2000	17.96	23.86	21.16	14.09	1.18	0.49	1500	28.32	15.40	3.89
2200	17.54	23.88	19.61	13.80	1.20	0.46	1600	28.44	15.19	3.86
2400	17.17	23.82	18.25	13.44	1.22	0.44	1700	28.69	15.13	3.85
2600	16.77	23.85	17.09	13.36	1.25	0.42	1800	28.19	14.91	3.84
2800	16.43	23.75	16.04	13.02	1.26	0.40	1900	27.81	14.69	3.93
3000	16.12	23.63	15.16	12.81	1.27	0.39	2000	27.52	14.52	3.99
3200	15.77	23.66	14.33	12.87	1.30	0.37	2100	27.07	14.40	3.98
3400	15.51	23.53	13.64	12.75	1.30	0.36	2200	26.65	14.20	3.90
3600	15.23	23.47	13.17	12.89	1.32	0.35	2300	26.39	13.95	4.01
3800	14.96	23.38	12.82	12.96	1.33	0.34	2400	26.12	13.53	4.02
4000	14.77	23.39	12.67	13.16	1.36	0.33	2500	25.88	13.12	3.97
4200	14.57	23.17	12.63	13.04	1.35	0.33	2600	25.55	12.93	3.98
4500	14.29	23.04	13.22	13.17	1.38	0.32	2700	25.37	12.81	4.04
5000	13.92	22.80	14.09	12.56	1.40	0.31	2800	25.25	12.58	3.99
6000	13.14	22.61	14.77	11.42	1.47	0.30	2900	24.93	12.50	3.98
7000	11.53	23.15	12.87	8.78	1.70	0.28	3000	24.72	12.37	4.11
8000	8.31	22.41	10.45	8.13	2.11	0.27	3100	24.30	12.13	4.09
9000	4.72	21.11	7.66	7.63	2.41	0.27	3200	24.12	11.90	4.10
10000	1.90	19.12	7.05	7.36	2.46	0.24	3300	23.80	11.87	4.20
11000	0.42	14.97	7.52	7.75	1.87	0.21	3400	23.49	11.64	4.25
12000	-0.58	11.75	8.91	8.95	1.62	0.20	3500	23.43	11.21	4.21
13000	-0.88	7.79	12.57	11.48	1.32	0.31	3600	23.16	11.01	4.18
14000	-1.22	4.58	12.37	12.98	1.14	0.53	3700	23.04	10.66	4.28
15000	-3.55	5.04	5.69	5.46	1.12	0.62	3800	22.76	10.44	4.31
16000	-4.87	5.36	5.05	4.99	1.20	0.61	4000	22.28	10.06	4.12

REV. X1

GALI-5F+

120123

Page 7 of 11



IF/RF MICROWAVE COMPONENTS • ISO 9001 ISO 14001 AS 9100 CERTIFIED • RoHS compliant

P.O. Box 350166, Brooklyn, New York 11235-0003 (718) 934-4500 Fax (718) 332-4661



The Design Engineers Search Engine finds the model you need, Instantly • For detailed performance specs & shopping online see



Typical Performance Data

Definitions:

Input Return Loss = -S11 (dB)

Gain(Power Gain) = S21 (dB)

Reverse Isolation = -S12 (dB)

Output Return Loss = -S22 (dB)

TEST CONDITIONS: Icc = 40mA, Vd =4.12V @Temperature = +85degC

FREQ	Gain	Isolation	Input Return Loss	Output Return Loss	Stability		FREQ	IP3 Output	1dB Comp. Output	Noise Figure
					K	Delta				
(MHz)	(dB)	(dB)	(dB)	(dB)	K	Delta	(MHz)	(dBm)	(dBm)	(dB)
50	20.86	23.79	27.70	47.07	1.06	0.71	50	26.99	14.14	3.65
100	20.81	23.65	30.60	36.39	1.05	0.72	100	27.31	14.13	3.66
200	20.74	23.69	32.38	30.13	1.06	0.71	200	27.38	13.98	3.70
300	20.67	23.68	31.46	26.66	1.06	0.71	300	27.20	13.89	3.85
400	20.55	23.69	28.73	24.75	1.06	0.70	400	26.82	13.89	3.82
500	20.45	23.69	29.16	22.96	1.07	0.69	500	26.80	13.89	3.79
600	20.26	23.71	28.67	21.59	1.07	0.67	600	26.85	13.81	3.86
700	20.11	23.71	28.70	20.43	1.08	0.66	700	27.15	13.82	3.84
800	20.01	23.69	27.47	19.45	1.08	0.65	800	27.37	13.79	3.77
900	19.78	23.69	26.54	18.73	1.09	0.63	900	27.35	13.73	3.83
1000	19.62	23.70	26.33	18.03	1.10	0.62	1000	27.17	13.69	3.78
1200	19.28	23.65	24.50	16.92	1.10	0.60	1100	26.92	13.67	3.81
1400	18.87	23.65	23.55	16.00	1.12	0.57	1200	26.78	13.54	3.84
1600	18.51	23.68	22.05	15.36	1.14	0.54	1300	26.62	13.36	3.82
1800	18.10	23.66	20.87	14.65	1.16	0.51	1400	26.31	13.28	3.84
2000	17.72	23.62	19.12	14.16	1.17	0.49	1500	26.26	13.17	3.85
2200	17.34	23.59	17.86	13.84	1.19	0.46	1600	26.45	13.04	3.81
2400	16.94	23.55	16.89	13.43	1.21	0.44	1700	26.87	13.14	3.82
2600	16.55	23.64	15.89	13.33	1.24	0.41	1800	26.50	12.97	3.78
2800	16.24	23.47	15.00	12.97	1.24	0.40	1900	26.22	12.99	3.90
3000	15.90	23.38	14.27	12.75	1.25	0.39	2000	26.04	13.08	3.92
3200	15.59	23.42	13.53	12.78	1.28	0.37	2100	25.68	12.97	3.93
3400	15.31	23.32	12.93	12.68	1.28	0.36	2200	25.39	12.68	3.83
3600	15.02	23.29	12.55	12.81	1.31	0.34	2300	25.25	12.47	3.94
3800	14.80	23.16	12.19	12.88	1.31	0.34	2400	25.06	12.16	3.99
4000	14.57	23.23	12.07	13.09	1.35	0.33	2500	24.86	11.90	3.91
4200	14.41	22.98	12.04	13.02	1.34	0.33	2600	24.57	11.89	3.92
4500	14.09	22.86	12.62	13.21	1.37	0.32	2700	24.38	11.91	4.02
5000	13.73	22.66	13.43	12.76	1.40	0.31	2800	24.28	11.70	3.92
6000	12.93	22.46	14.12	11.83	1.47	0.30	2900	23.99	11.59	3.92
7000	11.32	23.00	12.54	9.24	1.72	0.27	3000	23.82	11.50	4.08
8000	8.12	22.28	10.34	8.50	2.14	0.27	3100	23.44	11.28	4.05
9000	4.59	21.03	7.61	7.94	2.44	0.26	3200	23.29	11.09	4.02
10000	1.78	19.06	7.01	7.64	2.50	0.23	3300	22.96	11.03	4.08
11000	0.31	14.97	7.48	7.93	1.90	0.20	3400	22.67	10.89	4.18
12000	-0.67	11.84	8.84	9.08	1.65	0.19	3500	22.62	10.43	4.13
13000	-0.97	7.83	12.47	11.50	1.33	0.30	3600	22.35	10.27	4.13
14000	-1.29	4.62	12.25	13.07	1.15	0.52	3700	22.21	9.91	4.20
15000	-3.61	5.04	5.66	5.50	1.13	0.62	3800	21.94	9.71	4.24
16000	-4.90	5.35	5.02	4.97	1.20	0.61	4000	21.51	9.48	4.05

REV. X1

GALI-5F+

120123

Page 8 of 11



IF/RF MICROWAVE COMPONENTS • ISO 9001 ISO 14001 AS 9100 CERTIFIED • RoHS compliant

P.O. Box 350166, Brooklyn, New York 11235-0003 (718) 934-4500 Fax (718) 332-4661



The Design Engineers Search Engine finds the model you need, Instantly • For detailed performance specs & shopping online see



Typical Performance Data

Definitions:

Input Return Loss = -S11 (dB)

Gain(Power Gain) = S21 (dB)

Reverse Isolation = -S12 (dB)

Output Return Loss = -S22 (dB)

TEST CONDITIONS: Icc = 60mA, Vd =4.20V @Temperature = +85degC

FREQ	Gain	Isolation	Input Return Loss	Output Return Loss	Stability		FREQ	IP3 Output	1dB Comp. Output	Noise Figure
					K	Delta				
(MHz)	(dB)	(dB)	(dB)	(dB)	K	Delta	(MHz)	(dBm)	(dBm)	(dB)
50	21.39	24.32	40.06	25.44	1.06	0.71	50	32.80	17.89	3.73
100	21.35	24.15	34.83	24.15	1.05	0.73	100	33.11	17.89	3.80
200	21.28	24.22	31.59	22.49	1.06	0.71	200	33.17	17.85	3.80
300	21.17	24.14	32.48	22.06	1.06	0.71	300	32.94	17.81	3.95
400	21.06	24.19	37.00	21.67	1.06	0.70	400	32.43	17.68	3.92
500	20.94	24.17	38.74	20.76	1.06	0.69	500	32.13	17.71	3.86
600	20.80	24.21	42.52	19.86	1.07	0.68	600	31.98	17.67	3.97
700	20.61	24.18	45.02	19.13	1.08	0.66	700	32.01	17.66	3.91
800	20.47	24.16	52.77	18.35	1.08	0.65	800	31.94	17.64	3.87
900	20.28	24.18	45.01	17.88	1.09	0.64	900	31.78	17.35	3.94
1000	20.08	24.17	41.56	17.34	1.10	0.62	1000	31.42	17.29	3.88
1200	19.69	24.14	35.89	16.42	1.11	0.60	1100	31.06	17.25	3.91
1400	19.31	24.14	31.09	15.60	1.13	0.57	1200	30.71	17.21	3.91
1600	18.90	24.12	28.13	15.04	1.15	0.54	1300	30.22	17.07	3.93
1800	18.50	24.09	25.08	14.40	1.17	0.51	1400	29.72	16.92	3.93
2000	18.08	24.05	22.66	13.99	1.19	0.49	1500	29.45	16.72	3.95
2200	17.68	24.02	20.87	13.73	1.21	0.46	1600	29.54	16.45	3.91
2400	17.30	23.98	19.12	13.37	1.23	0.44	1700	29.64	16.27	3.92
2600	16.89	24.03	17.97	13.33	1.26	0.41	1800	29.09	15.92	3.88
2800	16.57	23.89	16.88	12.99	1.27	0.40	1900	28.67	15.65	4.01
3000	16.24	23.78	15.78	12.79	1.27	0.39	2000	28.36	15.33	4.03
3200	15.90	23.77	14.98	12.86	1.30	0.37	2100	27.87	15.16	4.02
3400	15.65	23.66	14.15	12.75	1.30	0.36	2200	27.40	14.95	3.97
3600	15.34	23.61	13.68	12.89	1.33	0.35	2300	27.10	14.71	4.06
3800	15.09	23.49	13.33	12.95	1.34	0.34	2400	26.79	14.33	4.07
4000	14.89	23.51	13.04	13.13	1.36	0.33	2500	26.56	13.84	4.03
4200	14.69	23.27	13.07	13.00	1.35	0.33	2600	26.21	13.65	4.07
4500	14.41	23.16	13.60	13.06	1.38	0.32	2700	26.01	13.48	4.11
5000	14.03	22.91	14.56	12.38	1.40	0.31	2800	25.91	13.19	4.05
6000	13.29	22.71	15.19	11.07	1.46	0.31	2900	25.57	13.07	4.09
7000	11.66	23.28	13.06	8.47	1.69	0.28	3000	25.35	12.97	4.18
8000	8.43	22.49	10.52	7.88	2.09	0.28	3100	24.95	12.63	4.20
9000	4.84	21.19	7.69	7.43	2.39	0.28	3200	24.77	12.52	4.19
10000	1.98	19.17	7.08	7.20	2.44	0.25	3300	24.41	12.46	4.24
11000	0.50	14.94	7.56	7.60	1.84	0.22	3400	24.19	12.26	4.34
12000	-0.48	11.72	8.98	8.85	1.60	0.20	3500	24.06	11.81	4.30
13000	-0.80	7.74	12.65	11.47	1.30	0.32	3600	23.83	11.52	4.25
14000	-1.17	4.56	12.46	12.89	1.14	0.53	3700	23.72	11.21	4.33
15000	-3.51	5.02	5.70	5.44	1.12	0.63	3800	23.42	11.02	4.42
16000	-4.84	5.34	5.05	4.95	1.19	0.61	4000	22.87	10.75	4.24

REV. X1
GALI-5F+
120123
Page 9 of 11



IF/RF MICROWAVE COMPONENTS • ISO 9001 ISO 14001 AS 9100 CERTIFIED • RoHS compliant
P.O. Box 350166, Brooklyn, New York 11235-0003 (718) 934-4500 Fax (718) 332-4661



The Design Engineers Search Engine finds the model you need, Instantly • For detailed performance specs & shopping online see



Typical Performance Curves

GAIN vs. TEMPERATURE

INPUT POWER = -20dBm, CURRENT = 50mA

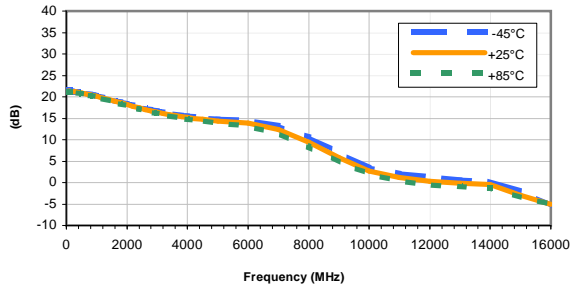

GAIN vs. CURRENT

INPUT POWER = -20dBm, Temperature = +25°C

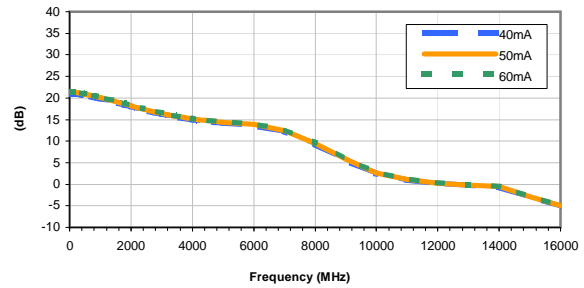

ISOLATION vs. TEMPERATURE

INPUT POWER = -20dBm, CURRENT = 50mA

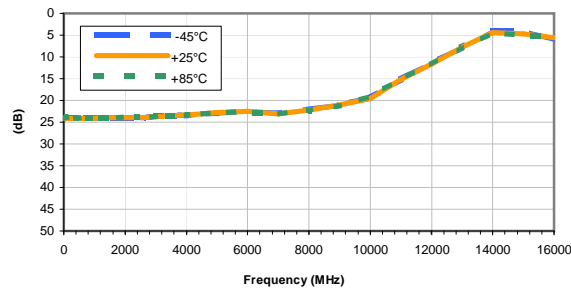

ISOLATION vs. CURRENT

INPUT POWER = -20dBm, Temperature = +25°C

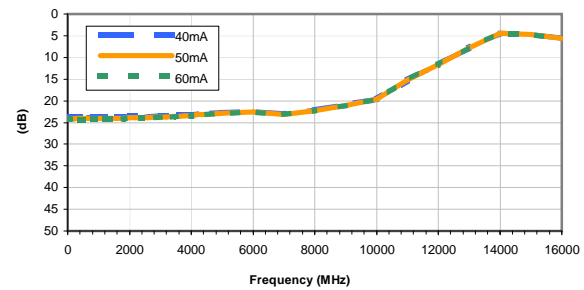

INPUT RETURN LOSS vs. TEMPERATURE

INPUT POWER = -20dBm, CURRENT = 50mA

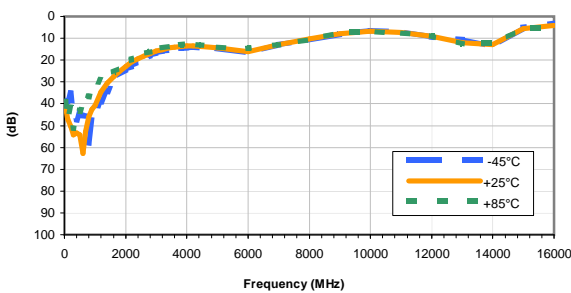

INPUT RETURN LOSS vs. CURRENT

INPUT POWER = -20dBm, Temperature = +25°C

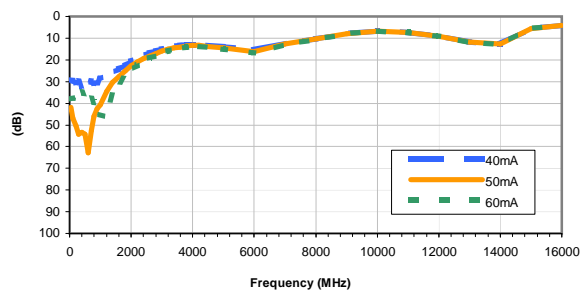

OUTPUT RETURN LOSS vs. TEMPERATURE

INPUT POWER = -20dBm, CURRENT = 50mA

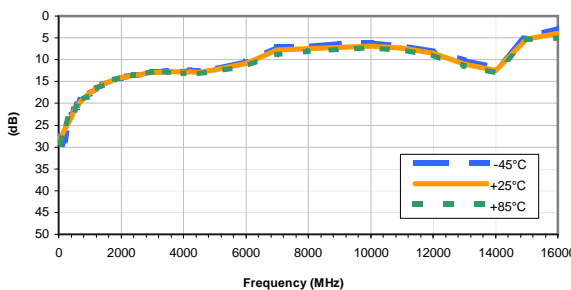

OUTPUT RETURN LOSS vs. CURRENT

INPUT POWER = -20dBm, Temperature = +25°C

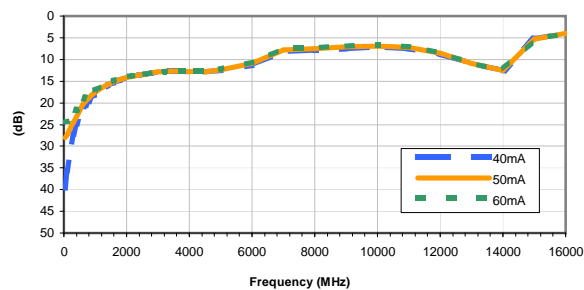

Typical Performance Curves

OUTPUT IP3 vs. TEMPERATURE

INPUT POWER = -20dBm, CURRENT = 50mA

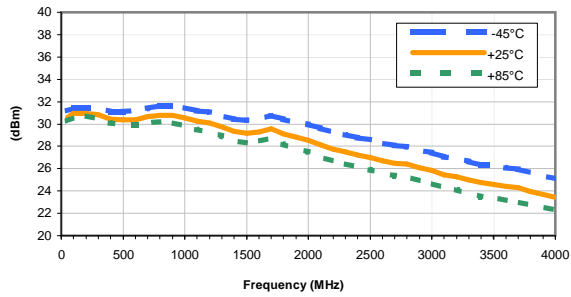

OUTPUT IP3 vs. CURRENT

INPUT POWER = -20dBm, Temperature = +25°C

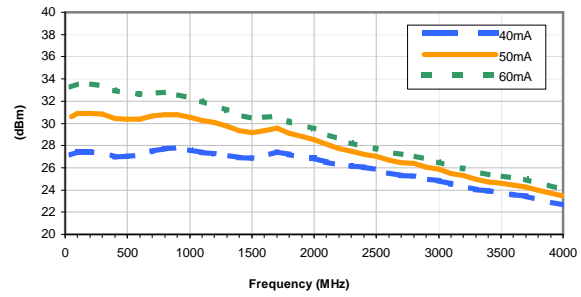

OUTPUT POWER at 1dB Compression vs. TEMPERATURE

CURRENT = 50mA

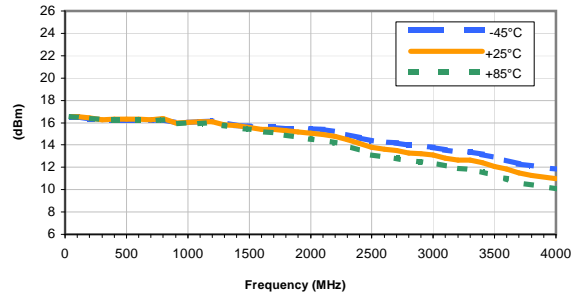

OUTPUT POWER at 1dB Compression vs. CURRENT

Temperature = +25°C

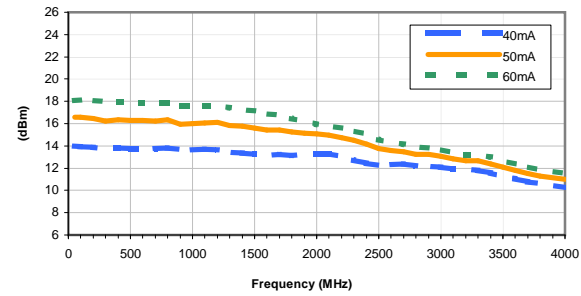

Noise Figure vs. TEMPERATURE

CURRENT = 50mA

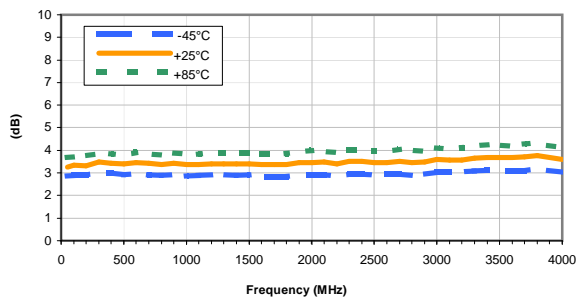

Noise Figure vs. CURRENT

Temperature = +25°C

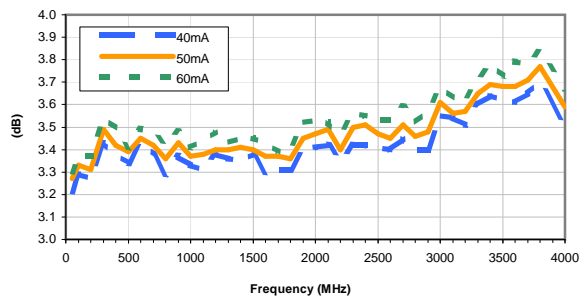

Typical Performance Curves

GAIN vs. TEMPERATURE

INPUT POWER = -20dBm, CURRENT = 50mA

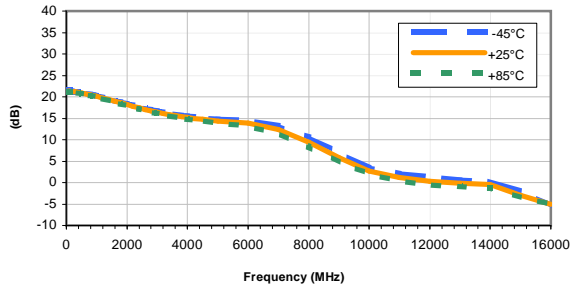

GAIN vs. CURRENT

INPUT POWER = -20dBm, Temperature = +25°C

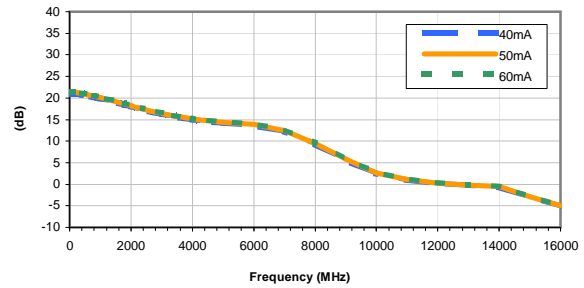

ISOLATION vs. TEMPERATURE

INPUT POWER = -20dBm, CURRENT = 50mA

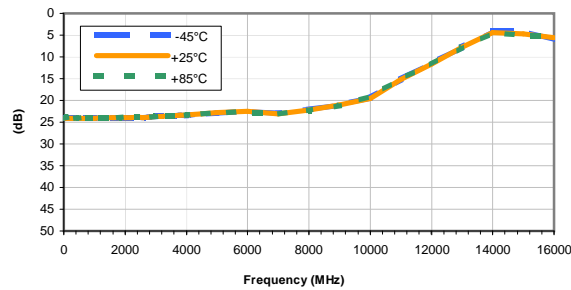

ISOLATION vs. CURRENT

INPUT POWER = -20dBm, Temperature = +25°C

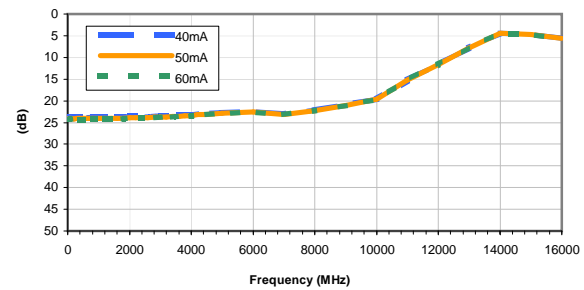

INPUT RETURN LOSS vs. TEMPERATURE

INPUT POWER = -20dBm, CURRENT = 50mA

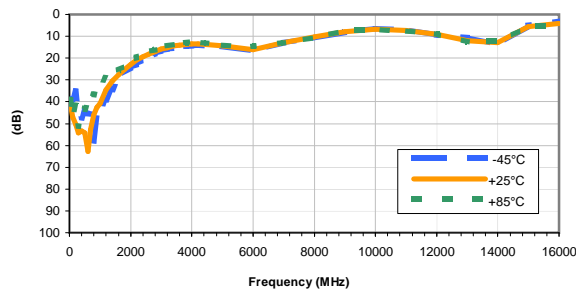

INPUT RETURN LOSS vs. CURRENT

INPUT POWER = -20dBm, Temperature = +25°C

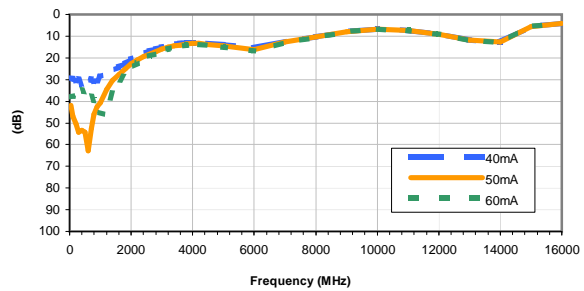

OUTPUT RETURN LOSS vs. TEMPERATURE

INPUT POWER = -20dBm, CURRENT = 50mA

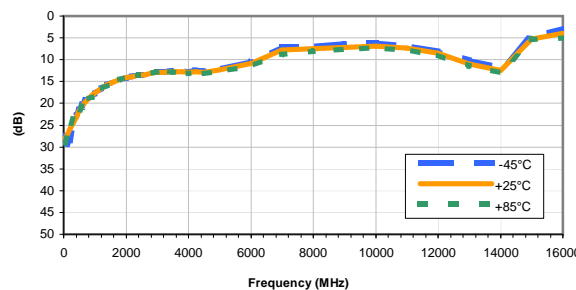

OUTPUT RETURN LOSS vs. CURRENT

INPUT POWER = -20dBm, Temperature = +25°C

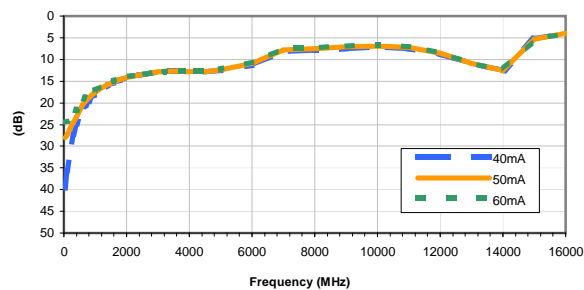

Typical Performance Curves

OUTPUT IP3 vs. TEMPERATURE

INPUT POWER = -20dBm, CURRENT = 50mA

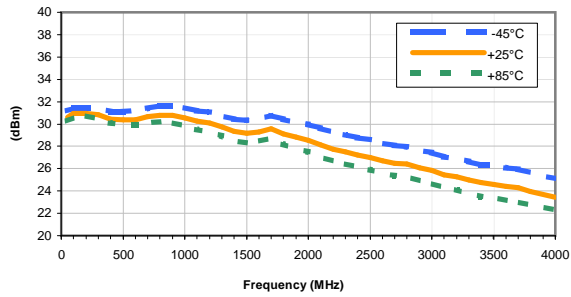

OUTPUT IP3 vs. CURRENT

INPUT POWER = -20dBm, Temperature = +25°C

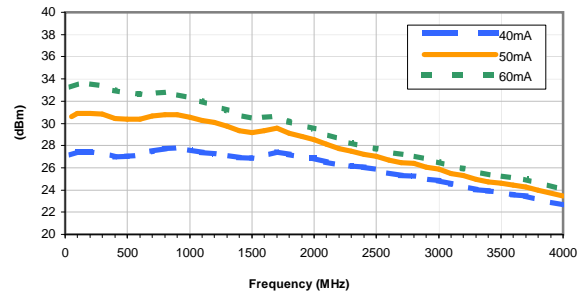

OUTPUT POWER at 1dB Compression vs. TEMPERATURE

CURRENT = 50mA

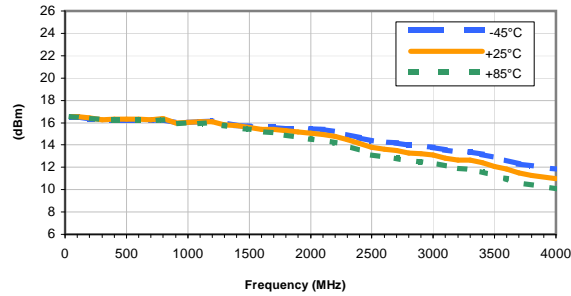

OUTPUT POWER at 1dB Compression vs. CURRENT

Temperature = +25°C

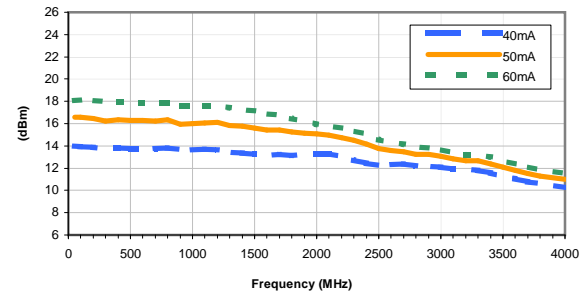

Noise Figure vs. TEMPERATURE

CURRENT = 50mA

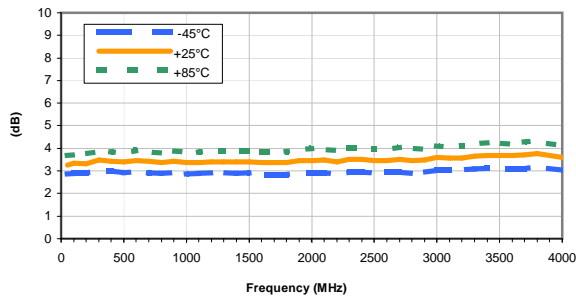

Noise Figure vs. CURRENT

Temperature = +25°C

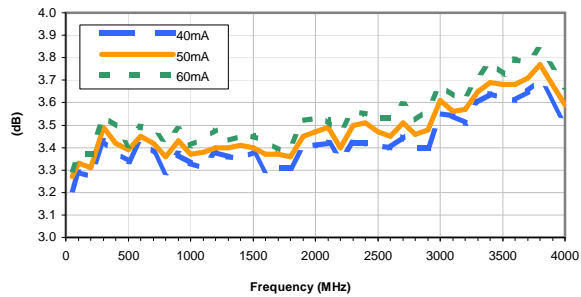

Outline Dimensions

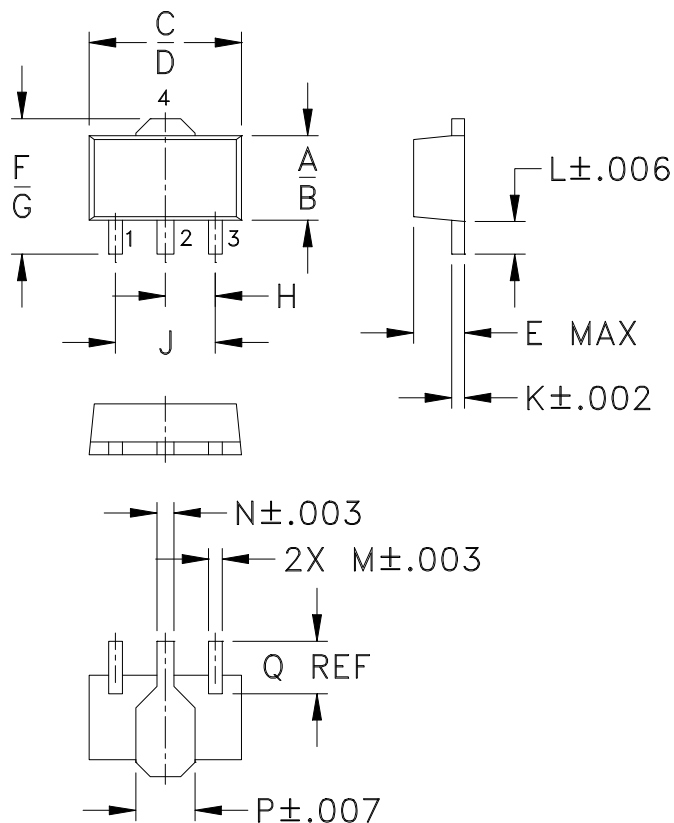

PCB Land Pattern

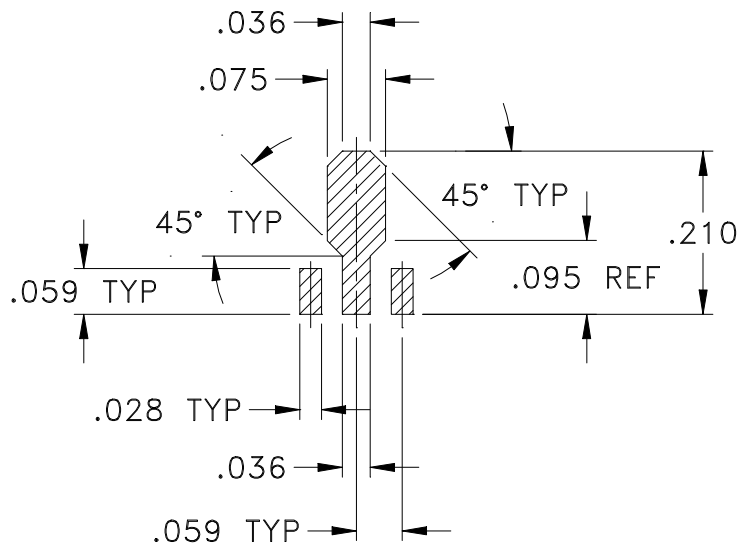

Suggested Layout,
Tolerance to be within $\pm .002$

CASE #	A	B	C	D	E	F	G	H	J	K	L	M
DF782	.102 (2.59)	.090 (2.29)	.181 (4.60)	.173 (4.39)	.063 (1.60)	.167 (4.24)	.155 (3.94)	.059 (1.50)	.118 (3.00)	.015 (0.38)	.041 (1.04)	.016 (0.41)

CASE #	N	P	Q	WT. GRAM
DF782	.019 (0.48)	.065 (1.65)	.062 (1.57)	.2

Dimensions are in inches (mm). Tolerances: 2 Pl. $\pm .01$; 3Pl. $\pm .005$

Notes:

- Case material: Plastic.
- Termination finish:
 For RoHS Case Styles: Tin-Silver alloy plate over Nickel barrier or Matte-Tin.
 All models, (+) suffix. See model Data sheet.
 For RoHS-5 Case Styles: Tin-Lead plate. All models, no (+) suffix.



INTERNET <http://www.minicircuits.com>

P.O. Box 350166, Brooklyn, New York 11235-0003 (718) 934-4500 Fax (718) 332-4661

Distribution Centers NORTH AMERICA 800-654-7949 • 417-335-5935 • Fax 417-335-5945 • EUROPE 44-1252-832600 • Fax 44-1252-837010

Mini-Circuits ISO 9001 & ISO 14001 Certified

Tape & Reel Packaging TR-F55

DEVICE ORIENTATION IN T&R

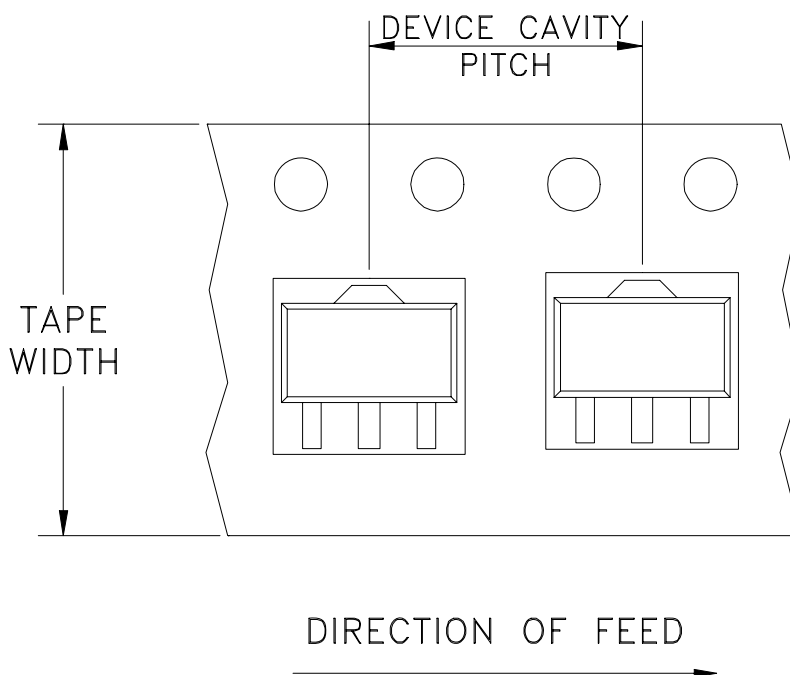

Tape Width, mm	Device Cavity Pitch, mm	Reel Size, inches	Devices per Reel	
12	8	7	Small quantity standard (see note)	20
				50
				100
				200
				500
			Standard	1000

Note: Please consult individual model data sheet to determine device per reel availability.

Mini-Circuits carrier tape materials provide protection from ESD (Electro-Static Discharge) during handling and transportation. Tapes are static dissipative and comply with industry standards EIA-481/EIA-541.

Go to: www.minicircuits.com/pages/pdfs/tape.pdf



INTERNET <http://www.minicircuits.com>

P.O. Box 350166, Brooklyn, New York 11235-0003 (718) 934-4500 Fax (718) 332-4661

Distribution Centers NORTH AMERICA 800-654-7949 • 417-335-5935 • Fax 417-335-5945 • EUROPE 44-1252-832600 • Fax 44-1252-837010

Mini-Circuits ISO 9001 & ISO 14001 Certified

THIRD ANGLE PROJECTION

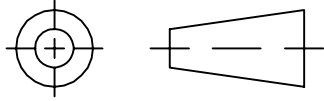

REVISIONS

REV	ECN No.	DESCRIPTION	DATE	DR	AUTH
A	M76190	CHANGED DISCRIPTION	04/01	GF	CT
B	M82575	UPDATED DRAWING	08/05/02	AV	LC
C	M102713	ADDED NOTE 2 & "...WITH SMOBC"	01/17/06	MMG	IL
D	M108434	UPDATED DRAWING PER TB-409+	11/14/06	PW	IG

SUGGESTED MOUNTING CONFIGURATION
FOR DF782 CASE STYLE, "mz" PIN CONNECTION

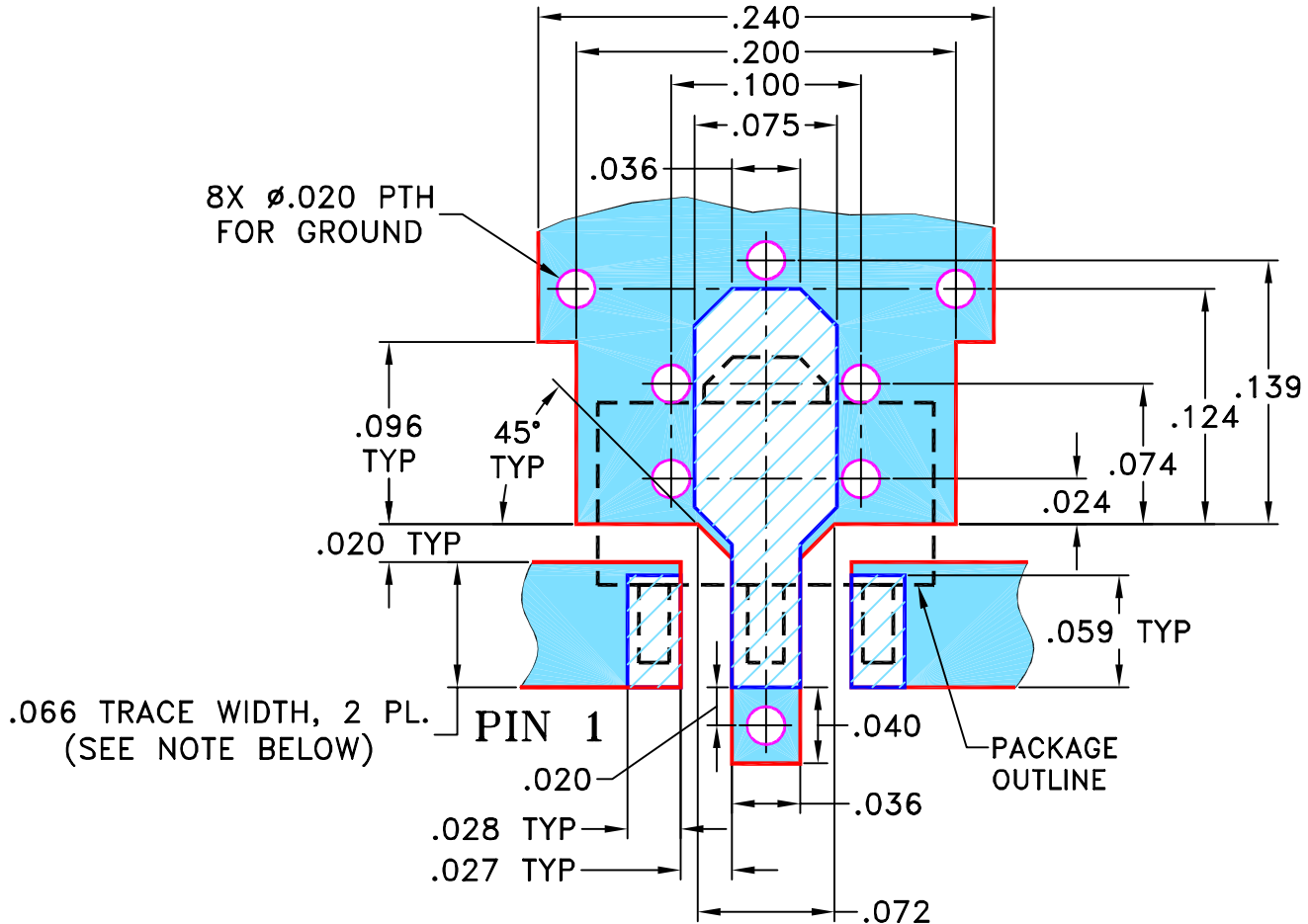

- NOTES:** 1. TRACE WIDTH IS SHOWN FOR ROGERS R04350B WITH DIELECTRIC THICKNESS .030" ± .002"; COPPER: 1/2 OZ. EACH SIDE. FOR OTHER MATERIALS TRACE WIDTH MAY NEED TO BE MODIFIED.
2. BOTTOM SIDE OF THE PCB IS CONTINUOUS GROUND PLANE.



DENOTES PCB COPPER LAYOUT WITH SMOBC (SOLDER MASK OVER BARE COPPER)



DENOTES COPPER LAND PATTERN FREE OF SOLDER MASK

UNLESS OTHERWISE SPECIFIED

INITIALS

DATE

DIMENSIONS ARE IN INCHES

TOLERANCES ON:

2 PL DECIMALS ±

3 PL DECIMALS ± .005

ANGLES ±

FRACTIONS ±



DRAWN

AV

01/15/01

CHECKED

YB

01/23/01

APPROVED

DB

01/23/01

Mini-Circuits®

THIS DOCUMENT AND ITS CONTENTS ARE THE PROPERTY OF MINI-CIRCUITS. EXCEPT FOR USE EXPRESSLY GRANTED, IN WRITING, TO ITS VENDORS, VENDEE AND THE UNITED STATES GOVERNMENT, MINI-CIRCUITS RESERVES ALL PROPRIETARY DESIGN, USE, MANUFACTURING AND REPRODUCTION RIGHTS THERETO. THESE CONTENTS SHALL NOT BE USED, DUPLICATED OR DISCLOSED TO ANY OUTSIDE PARTY, IN WHOLE OR IN PART, WITHOUT WRITTEN PERMISSION OF MINI-CIRCUITS.



Mini-Circuits®

13 Neptune Avenue
Brooklyn NY 11235

PL, mz, DF782, GALI, TB-409-XXX+

SIZE

A

CODE IDENT

15542

DRAWING NO:

98-PL-019

REV:

D

FILE:

98PL019

SCALE:

10:1

SHEET:

1 OF 1

ASHEETA1.DWG REV:A DATE:01/12/95

Evaluation Board and Circuit

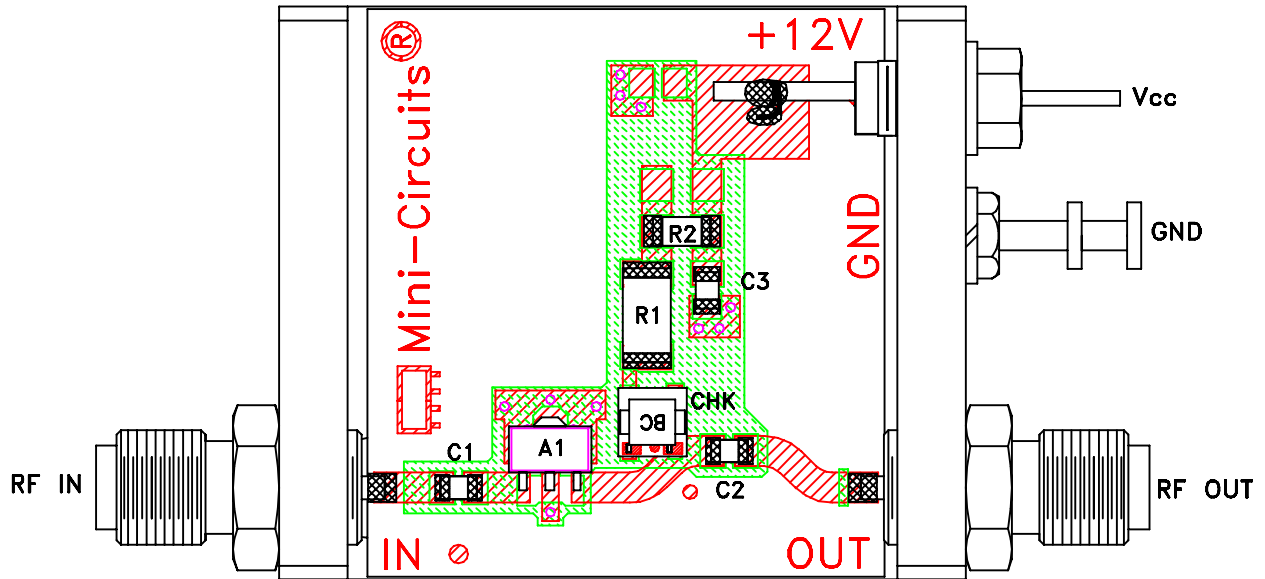

TB-409-5F+

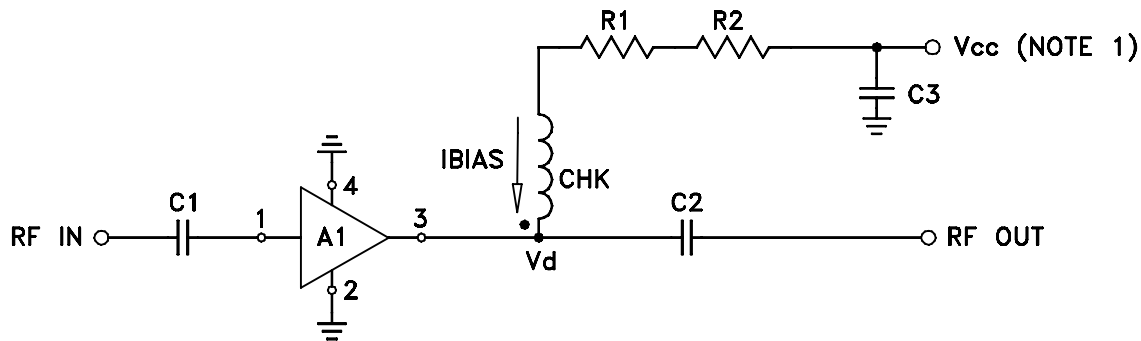

COMPONENT	VALUE
A1	Gali-5F(+)
C1 (NOTE 4)	2400 pF
C2 (NOTE 4)	2400 pF
C3 (bypass)	0.1 uF
R1	154 Ohms, 0.75W
R2	0 Ohm, 0.25W
CHK	Mini-Circuits TCCH-80+

Schematic Diagram

NOTE:

1. Vcc voltage: +12±0.2V.
2. SMA Female connectors.
3. PCB material: Rogers RO4350 or equivalent, dielectric constant=3.5, dielectric thickness=.030 inch.
4. Capacitors, C1 & C2 should be free of resonance up to the highest frequency specified.

Mini-Circuits®

All Mini-Circuits products are manufactured under exacting quality assurance and control standards, and are capable of meeting published specifications after being subjected to any or all of the following physical and environmental test.

Specification	Test/Inspection Condition	Reference/Spec
Operating Temperature	-45° to 85°C or -40° to 85°C Ambient Environment	Individual Model Data Sheet
Storage Temperature	-65° to 150° C Ambient Environment	Individual Model Data Sheet
Thermal Shock	-55° to 100°C, 100 cycles	MIL-STD-202, Method 107, Condition A-3, except +100°C
Mechanical Shock	1.5Kg, 0.5 ms, 5 shock pulses, Y1 direction only	MIL-STD-883, Method 2002, Condition B, except Y1 direction only
Vibration (Variable Frequency)	50g peak	MIL-STD-883, Method 2007, Condition B
Autoclave	15 psig, 100% RH, 121°C, 96 hours	JESD22-A102, Condition C
HAST	130°C, 85% RH, 96 hours	JESD22-A110
Solderability	10X Magnification	J-STD-002, Para 4.2.5, Test S, 95% Coverage
Solder Reflow Heat	Sn-Pb Eutetic Process: 240°C peak Pb-Free Process: 260°C peak	J-STD-020, Table 4-1, 4-2 and 5-2; Figure 5-1
Moisture Sensitivity: Level 1	Bake at 125°C for 24 hours Soak at 85°C/85% RH for 168 hours, Reflow 3 cycles at 260°C peak	J-STD-020
Marking Resistance to Solvents	Isopropyl alcohol + mineral spirits at 25°C; terpene defluxer at 25°C; distilled water + proylene glycol monomethyl ether +	MIL-STD-202, Method 215



All Mini-Circuits products are manufactured under exacting quality assurance and control standards, and are capable of meeting published specifications after being subjected to any or all of the following physical and environmental test.

Specification	Test/Inspection Condition	Reference/Spec
	monoethanolamine at 63°C to 70°C	