

Surface Mount

Monolithic Amplifier

DC-4 GHz

Features

- InGaP HBT microwave amplifier
- Miniature SOT-89 package
- Internally Matched to 50 Ohms
- Frequency range, DC to 4 GHz
- Output power, 13.4 dBm typ.
- Excellent package for heat dissipation, exposed metal bottom
- Low thermal resistance for high reliability
- Aqueous washable
- Protected by US Patent 6,943,629

Applications

- Cellular
- PCS
- Communication receivers & transmitters

General Description

Gali⁺33+ (RoHS compliant) is a wideband amplifier offering high dynamic range. Lead finish is SnAgNi. It has repeatable performance from lot to lot, and is enclosed in a SOT-89 package. It uses patented Transient Protected Darlington configuration and is fabricated using InGaP HBT technology. Expected MTTF is 13,000 years at 85°C case temperature. Gali⁺33+ is designed to be rugged for ESD and supply switch-on transients.



Gali⁺33+

CASE STYLE: DF782

+RoHS Compliant

The +Suffix identifies RoHS Compliance. See our web site for RoHS Compliance methodologies and qualifications

simplified schematic and pin description

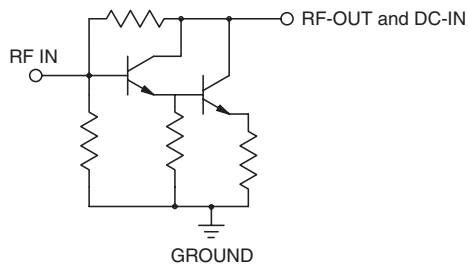

Function	Pin Number	Description
RF IN	1	RF input pin. This pin requires the use of an external DC blocking capacitor chosen for the frequency of operation.
RF-OUT and DC-IN	3	RF output and bias pin. DC voltage is present on this pin; therefore a DC blocking capacitor is necessary for proper operation. An RF choke is needed to feed DC bias without loss of RF signal due to the bias connection, as shown in "Recommended Application Circuit".
GND	2,4	Connections to ground. Use via holes as shown in "Suggested Layout for PCB Design" to reduce ground path inductance for best performance.

Notes

- A. Performance and quality attributes and conditions not expressly stated in this specification document are intended to be excluded and do not form a part of this specification document.
B. Electrical specifications and performance data contained in this specification document are based on Mini-Circuit's applicable established test performance criteria and measurement instructions.
C. The parts covered by this specification document are subject to Mini-Circuits standard limited warranty and terms and conditions (collectively, "Standard Terms"); Purchasers of this part are entitled to the rights and benefits contained therein. For a full statement of the Standard Terms and the exclusive rights and remedies thereunder, please visit Mini-Circuits' website at www.minicircuits.com/MCLStore/terms.jsp



Electrical Specifications at 25°C and 40mA, unless noted

Parameter		Min.	Typ.	Max.	Units
Frequency Range*		DC		4	GHz
Gain	f=0.1 GHz	—	19.3	—	dB
	f=1 GHz	—	18.7	—	
	f=2 GHz	16	17.5	—	
	f=3 GHz	—	16.3	—	
	f=4 GHz	—	15.5	—	
	f=6 GHz	—	15.8	—	
Input Return Loss	f= DC to 3 GHz		12.5		dB
	f= 3 to 4 GHz		9.5		
Output Return Loss	f= DC to 3 GHz		21		dB
	f= 3 to 4 GHz		17.5		
Output Power @ 1 dB compression	f=2 GHz	11.4	13.4	—	dBm
Output IP3	f=2 GHz		28		dBm
Noise Figure	f=2 GHz		3.9		dB
Recommended Device Operating Current			40		mA
Device Operating Voltage		3.8	4.3	4.8	V
Device Voltage Variation vs. Temperature at 40 mA			-2.9		mV/°C
Device Voltage Variation vs. Current at 25°C			3.8		mV/mA
Thermal Resistance, junction-to-case ¹			110		°C/W

*Guaranteed specification DC-4 GHz. Low frequency cut off determined by external coupling capacitors.

Absolute Maximum Ratings

Parameter	Ratings
Operating Temperature*	-45°C to 85°C
Storage Temperature	-65°C to 150°C
Operating Current	55mA
Input Power	13dBm

Note: Permanent damage may occur if any of these limits are exceeded.

These ratings are not intended for continuous normal operation.

¹Case is defined as ground leads.

*Based on typical case temperature rise 3°C above ambient.

Notes

- A. Performance and quality attributes and conditions not expressly stated in this specification document are intended to be excluded and do not form a part of this specification document.
- B. Electrical specifications and performance data contained in this specification document are based on Mini-Circuit's applicable established test performance criteria and measurement instructions.
- C. The parts covered by this specification document are subject to Mini-Circuits standard limited warranty and terms and conditions (collectively, "Standard Terms"); Purchasers of this part are entitled to the rights and benefits contained therein. For a full statement of the Standard Terms and the exclusive rights and remedies thereunder, please visit Mini-Circuits' website at www.minicircuits.com/MCLStore/terms.jsp



Product Marking

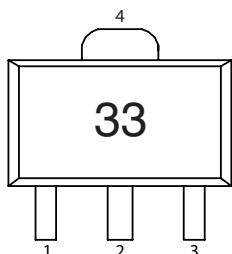

Markings in addition to model number designation may appear for internal quality control purposes.

Additional Detailed Technical Information

Additional information is available on our web site. To access this information enter the model number on our web site home page.

Performance data, graphs, s-parameter data set (.zip file)

Case Style: DF782

Plastic package, exposed paddle, lead finish: tin-silver over nickel

Tape & Reel: F55

7" reels with 20, 50, 100, 200, 500, 1K devices.

Suggested Layout for PCB Design: PL-019

Evaluation Board: TB-409-33+

Environmental Ratings: ENV08T2

Recommended Application Circuit

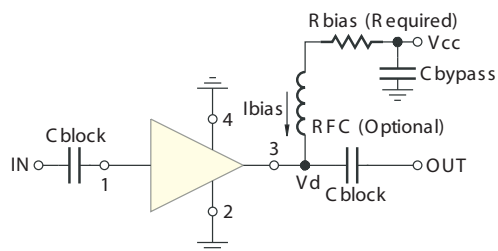

Test Board includes case, connectors, and components (in bold) soldered to PCB

R BIAS	
Vcc	"1%" Res. Values (ohms) for Optimum Biasing
7	69.8
8	93.1
9	115
10	140
11	165
12	191
13	215
14	243
15	267
16	287
17	316
18	340
19	365
20	392

Notes

- A. Performance and quality attributes and conditions not expressly stated in this specification document are intended to be excluded and do not form a part of this specification document.
- B. Electrical specifications and performance data contained in this specification document are based on Mini-Circuit's applicable established test performance criteria and measurement instructions.
- C. The parts covered by this specification document are subject to Mini-Circuits standard limited warranty and terms and conditions (collectively, "Standard Terms"); Purchasers of this part are entitled to the rights and benefits contained therein. For a full statement of the Standard Terms and the exclusive rights and remedies thereunder, please visit Mini-Circuits' website at www.minicircuits.com/MCLStore/terms.jsp



ESD Rating

Human Body Model (HBM): Class 1B (500v to < 1000v) in accordance with ANSI/ESD STM 5.1 - 2001

Machine Model (MM): Class M1 (< 100v) in accordance with ANSI/ESD STM 5.2 - 1999

MSL Rating

Moisture Sensitivity: MSL1 in accordance with IPC/JEDECJ-STD-020C

No.	Test Required	Condition	Standard	Quantity
1	Visual Inspection	Low Power Microscope Magnification 40x	MIP-IN-0003 (MCT spec)	45 units
2	Electrical Test	Room Temperature	SCD (MCL spec)	45 units
3	SAM Analysis	Less than 10% growth in term of delamination	J-Std-020C (Jedec Standard)	45 units
4	Moisture Sensitivity Level 1	Bake at 125°C for 24 hours Soak at 85°C/85%RH for 168 hours Reflow 3 cycles at 260°C peak	J-Std-020C (Jedec Standard)	45 units

MSL Test Flow Chart



Notes

- A. Performance and quality attributes and conditions not expressly stated in this specification document are intended to be excluded and do not form a part of this specification document.
- B. Electrical specifications and performance data contained in this specification document are based on Mini-Circuit's applicable established test performance criteria and measurement instructions.
- C. The parts covered by this specification document are subject to Mini-Circuits standard limited warranty and terms and conditions (collectively, "Standard Terms"); Purchasers of this part are entitled to the rights and benefits contained therein. For a full statement of the Standard Terms and the exclusive rights and remedies thereunder, please visit Mini-Circuits' website at www.minicircuits.com/MCLStore/terms.jsp



Typical Performance Data

**NOTE: Use PDF Bookmarks to view DATA at required conditions
or to view GRAPHS.**

Definitions:

Input Return Loss = -S11 (dB)

Gain(Power Gain) = S21 (dB)

Reverse Isolation = -S12 (dB)

Output Return Loss = -S22 (dB)

TEST CONDITIONS: INPUT POWER = -25dBm, Icc = 40mA, Vd = 4.26V @Temperature = +25degC

FREQ	Gain	Isolation	Input Return Loss	Output Return Loss	Stability		FREQ	IP3 Output	1dB Comp. Output	Noise Figure
(MHz)	(dB)	(dB)	(dB)	(dB)	K	Delta	(MHz)	(dBm)	(dBm)	(dB)
50	19.83	22.56	31.21	26.25	1.05	0.73	50	28.26	14.52	3.04
100	19.80	21.89	39.46	27.86	1.03	0.79	100	27.93	14.22	3.18
150	19.81	22.16	32.30	27.06	1.04	0.76	200	28.68	14.33	3.01
200	19.80	22.24	29.43	27.70	1.04	0.76	300	28.26	14.32	3.09
300	19.70	22.15	27.57	27.80	1.04	0.75	400	28.13	14.38	3.02
400	19.71	22.17	26.09	26.99	1.04	0.76	500	27.80	14.37	3.11
500	19.64	21.95	24.72	26.91	1.03	0.77	600	27.69	14.19	3.04
600	19.66	22.02	22.23	26.83	1.03	0.77	700	27.97	14.14	3.19
700	19.54	22.16	21.93	26.61	1.04	0.74	800	28.48	13.81	3.09
800	19.50	22.11	20.45	25.81	1.04	0.74	900	28.28	13.73	3.12
1000	19.38	22.12	18.72	25.00	1.05	0.74	1000	27.76	13.63	3.02
1200	19.23	22.32	17.72	23.30	1.06	0.71	1100	28.06	13.80	3.08
1400	19.07	22.39	16.50	21.85	1.06	0.69	1200	28.13	13.76	3.08
1600	18.92	22.52	15.66	20.56	1.08	0.68	1300	27.81	13.68	3.08
1800	18.77	22.70	14.87	19.17	1.09	0.66	1400	27.57	13.75	3.07
2000	18.58	22.86	14.12	18.03	1.10	0.63	1500	27.48	13.44	3.10
2200	18.39	22.99	13.59	17.19	1.12	0.62	1600	27.78	13.57	3.14
2400	18.23	23.06	13.00	16.37	1.13	0.61	1700	28.20	13.31	3.02
2600	18.05	23.20	12.29	15.68	1.14	0.59	1800	27.88	13.57	3.09
2800	17.84	23.46	12.01	15.18	1.17	0.56	1900	27.34	13.39	3.08
3000	17.73	23.56	11.64	14.79	1.18	0.55	2000	27.00	13.28	3.10
3200	17.55	23.73	11.24	14.56	1.20	0.54	2100	26.76	13.13	3.06
3400	17.47	23.91	10.79	14.44	1.21	0.52	2200	26.40	12.69	3.05
3600	17.35	24.06	10.62	14.18	1.23	0.51	2300	26.29	12.67	3.02
3800	17.23	24.26	10.51	14.16	1.25	0.49	2400	25.93	12.54	3.10
4000	17.15	24.35	10.42	14.24	1.26	0.48	2500	25.49	12.75	3.06
4200	17.12	24.52	10.23	14.31	1.27	0.47	2600	25.32	12.59	3.19
4400	17.05	24.53	10.39	14.10	1.28	0.46	2700	24.93	12.52	3.08
4600	17.09	24.83	10.38	13.75	1.30	0.44	2800	24.69	12.44	3.15
5000	17.05	24.90	10.87	12.88	1.30	0.43	2900	24.25	12.36	3.11
5500	17.10	24.92	11.97	11.05	1.27	0.42	3000	24.00	12.23	3.16
6000	17.23	24.60	14.11	9.26	1.20	0.43	3100	23.60	11.60	3.10
6500	17.43	24.58	17.35	7.46	1.11	0.42	3200	23.18	12.03	3.19
7000	17.20	24.21	22.41	6.14	1.03	0.41	3300	22.85	11.95	3.19
7500	16.14	23.96	19.10	5.44	1.05	0.39	3400	22.52	11.94	3.24
8000	14.16	23.88	14.43	5.34	1.20	0.34	3500	22.40	11.48	3.17
8500	11.98	24.44	11.88	5.36	1.51	0.28	3600	22.21	11.31	3.23
9000	9.71	23.57	10.79	5.68	1.73	0.23	3700	21.97	11.42	3.11
9500	7.77	22.80	9.89	5.95	1.92	0.19	3800	21.78	10.98	3.18
10000	6.09	21.44	9.08	5.97	1.90	0.16	4000	21.22	10.64	3.13

REV. X1
GALI-33+
080127

Page 1 of 11



IF/RF MICROWAVE COMPONENTS • ISO 9001 ISO 14001 AS 9100 CERTIFIED • RoHS compliant

P.O. Box 350166, Brooklyn, New York 11235-0003 (718) 934-4500 Fax (718) 332-4661



The Design Engineers Search Engine finds the model you need, Instantly • For detailed performance specs & shopping online see



Typical Performance Data

Definitions:

Input Return Loss = -S11 (dB)

Gain(Power Gain) = S21 (dB)

Reverse Isolation = -S12 (dB)

Output Return Loss = -S22 (dB)

TEST CONDITIONS: INPUT POWER = -25dBm, Icc = 32mA, Vd = 4.21V @Temperature = +25degC

FREQ	Gain	Isolation	Input Return Loss	Output Return Loss	Stability		FREQ	IP3 Output	1dB Comp. Output	Noise Figure
(MHz)	(dB)	(dB)	(dB)	(dB)	K	Delta	(MHz)	(dBm)	(dBm)	(dB)
50	19.46	21.91	26.07	20.92	1.04	0.76	50	24.60	11.56	3.06
100	19.42	22.25	31.49	22.54	1.05	0.72	100	24.30	11.11	3.12
150	19.42	21.83	25.21	22.19	1.04	0.76	200	24.90	11.44	3.03
200	19.40	21.63	26.68	21.91	1.03	0.78	300	24.51	11.45	3.04
300	19.33	22.05	25.50	22.22	1.05	0.73	400	24.40	11.38	3.03
400	19.32	21.80	23.96	22.04	1.04	0.76	500	24.11	11.46	3.08
500	19.27	21.73	23.71	22.05	1.04	0.76	600	24.07	11.25	3.05
600	19.31	21.79	21.71	22.54	1.04	0.76	700	24.27	11.30	3.17
700	19.20	21.77	21.58	22.49	1.04	0.75	800	24.71	10.86	3.08
800	19.15	21.94	20.03	22.03	1.05	0.73	900	24.56	10.90	3.10
1000	19.03	21.98	18.63	21.75	1.05	0.72	1000	24.10	10.81	3.01
1200	18.88	22.05	17.62	20.88	1.06	0.71	1100	24.43	11.02	3.07
1400	18.73	22.24	16.46	19.81	1.07	0.68	1200	24.50	10.76	3.05
1600	18.59	22.40	15.65	18.91	1.09	0.66	1300	24.27	10.83	3.06
1800	18.45	22.48	14.80	17.67	1.09	0.65	1400	24.17	10.98	3.07
2000	18.28	22.61	14.01	16.63	1.10	0.64	1500	24.17	10.73	3.10
2200	18.10	22.76	13.45	15.86	1.12	0.62	1600	24.47	10.87	3.13
2400	17.96	22.85	12.82	15.16	1.13	0.61	1700	24.81	10.55	3.02
2600	17.78	23.18	12.13	14.53	1.15	0.58	1800	24.64	10.90	3.03
2800	17.58	23.22	11.83	13.98	1.17	0.57	1900	24.27	10.73	3.06
3000	17.48	23.37	11.44	13.60	1.18	0.56	2000	24.10	10.69	3.07
3200	17.31	23.61	11.00	13.54	1.20	0.54	2100	23.91	10.52	3.06
3400	17.24	23.80	10.59	13.48	1.21	0.52	2200	23.73	10.10	2.99
3600	17.13	23.93	10.38	13.19	1.23	0.51	2300	23.69	10.06	3.02
3800	17.02	23.90	10.28	13.11	1.23	0.50	2400	23.48	9.92	3.05
4000	16.94	24.25	10.21	13.15	1.26	0.48	2500	23.22	10.30	3.07
4200	16.92	24.33	10.04	13.14	1.26	0.47	2600	23.30	10.01	3.15
4400	16.86	24.46	10.17	13.03	1.28	0.46	2700	23.06	10.23	3.09
4600	16.92	24.45	10.14	12.85	1.26	0.46	2800	22.95	10.23	3.14
5000	16.88	24.66	10.70	12.04	1.27	0.43	2900	22.64	10.18	3.08
5500	16.96	24.62	11.83	10.40	1.24	0.43	3000	22.48	10.03	3.16
6000	17.08	24.36	13.97	8.70	1.16	0.43	3100	22.14	9.64	3.09
6500	17.29	24.20	16.84	7.01	1.06	0.42	3200	21.80	10.11	3.16
7000	17.02	23.76	20.53	5.82	0.98	0.41	3300	21.59	10.11	3.16
7500	15.94	23.58	17.85	5.20	1.00	0.38	3400	21.30	10.25	3.23
8000	13.94	23.69	13.95	5.18	1.17	0.32	3500	21.25	9.95	3.15
8500	11.74	24.15	11.67	5.24	1.47	0.27	3600	21.10	9.81	3.23
9000	9.45	23.40	10.60	5.56	1.71	0.22	3700	20.90	9.79	3.08
9500	7.54	22.70	9.76	5.87	1.92	0.19	3800	20.76	9.52	3.11
10000	5.93	21.30	8.94	5.86	1.88	0.16	4000	20.27	9.49	3.11

Typical Performance Data

Definitions:

Input Return Loss = -S11 (dB)

Gain(Power Gain) = S21 (dB)

Reverse Isolation = -S12 (dB)

Output Return Loss = -S22 (dB)

TEST CONDITIONS: INPUT POWER = -25dBm, Icc = 48mA, Vd = 4.30V @Temperature = +25degC

FREQ	Gain	Isolation	Input Return Loss	Output Return Loss	Stability		FREQ	IP3 Output	1dB Comp. Output	Noise Figure
(MHz)	(dB)	(dB)	(dB)	(dB)	K	Delta	(MHz)	(dBm)	(dBm)	(dB)
50	20.09	21.77	27.94	31.29	1.02	0.82	50	31.25	16.64	3.10
100	20.05	22.07	32.45	34.92	1.03	0.79	100	30.88	16.39	3.20
150	20.05	22.21	34.69	32.73	1.03	0.78	200	31.86	16.52	3.02
200	20.02	22.21	28.77	33.53	1.03	0.78	300	31.43	16.48	3.14
300	19.96	22.14	27.27	32.60	1.03	0.78	400	31.28	16.44	3.04
400	19.95	22.20	25.50	31.53	1.03	0.77	500	30.89	16.47	3.16
500	19.90	22.26	24.03	30.84	1.04	0.76	600	30.78	16.33	3.06
600	19.89	22.20	21.89	30.46	1.03	0.77	700	31.06	16.19	3.23
700	19.75	22.35	21.55	29.63	1.04	0.74	800	31.68	15.94	3.11
800	19.74	22.35	20.24	28.00	1.04	0.74	900	31.42	15.88	3.15
1000	19.59	22.42	18.54	26.43	1.05	0.73	1000	30.74	15.73	3.05
1200	19.45	22.49	17.58	24.48	1.05	0.71	1100	31.14	15.86	3.10
1400	19.28	22.61	16.43	22.72	1.06	0.69	1200	31.06	15.81	3.11
1600	19.10	22.75	15.59	21.39	1.08	0.67	1300	30.67	15.65	3.11
1800	18.94	22.73	14.86	19.94	1.08	0.66	1400	30.24	15.68	3.13
2000	18.77	23.04	14.19	18.74	1.10	0.63	1500	29.97	15.43	3.12
2200	18.57	23.14	13.65	17.91	1.12	0.62	1600	30.16	15.49	3.17
2400	18.43	23.17	13.07	17.05	1.12	0.61	1700	30.63	15.20	3.02
2600	18.23	23.50	12.44	16.37	1.15	0.58	1800	30.17	15.35	3.10
2800	18.04	23.55	12.17	15.86	1.16	0.57	1900	29.48	15.27	3.06
3000	17.90	23.56	11.80	15.41	1.17	0.56	2000	29.09	15.09	3.15
3200	17.70	23.84	11.38	15.25	1.20	0.53	2100	28.67	14.91	3.08
3400	17.62	24.03	10.95	15.18	1.21	0.52	2200	28.22	14.59	3.09
3600	17.48	24.15	10.77	14.93	1.23	0.51	2300	27.95	14.42	3.03
3800	17.37	24.43	10.66	14.89	1.26	0.48	2400	27.43	14.28	3.14
4000	17.29	24.47	10.58	14.90	1.27	0.48	2500	26.94	14.32	3.10
4200	17.26	24.62	10.36	14.88	1.27	0.47	2600	26.50	13.95	3.21
4400	17.19	24.66	10.56	14.72	1.28	0.46	2700	26.08	13.72	3.11
4600	17.20	24.86	10.49	14.34	1.29	0.44	2800	25.69	13.69	3.21
5000	17.18	24.96	10.98	13.36	1.30	0.43	2900	25.23	13.48	3.12
5500	17.25	25.19	12.03	11.45	1.29	0.42	3000	24.91	13.35	3.20
6000	17.40	24.96	14.10	9.53	1.23	0.42	3100	24.51	12.57	3.14
6500	17.61	24.78	17.51	7.60	1.13	0.42	3200	24.09	12.97	3.21
7000	17.39	24.38	24.15	6.25	1.04	0.42	3300	23.66	12.87	3.23
7500	16.38	24.18	19.96	5.47	1.06	0.40	3400	23.30	12.72	3.25
8000	14.40	24.26	14.78	5.37	1.23	0.34	3500	23.16	12.37	3.20
8500	12.21	24.69	12.25	5.45	1.55	0.28	3600	22.91	12.13	3.29
9000	9.93	23.79	10.97	5.70	1.75	0.24	3700	22.70	12.23	3.16
9500	8.02	22.89	10.01	5.97	1.91	0.20	3800	22.53	11.70	3.19
10000	6.39	21.39	9.14	5.95	1.84	0.17	4000	21.97	11.35	3.15

Typical Performance Data

Definitions:

Input Return Loss = -S11 (dB)

Gain(Power Gain) = S21 (dB)

Reverse Isolation = -S12 (dB)

Output Return Loss = -S22 (dB)

TEST CONDITIONS: INPUT POWER = -25dBm, Icc = 40mA, Vd = 4.48V @Temperature = -45degC

FREQ	Gain	Isolation	Input Return Loss	Output Return Loss	Stability		FREQ	IP3 Output	1dB Comp. Output	Noise Figure
(MHz)	(dB)	(dB)	(dB)	(dB)	K	Delta	(MHz)	(dBm)	(dBm)	(dB)
50	19.83	21.43	30.25	25.60	1.01	0.83	50	28.87	14.39	2.73
100	19.83	22.03	39.21	28.51	1.03	0.78	100	28.66	14.02	2.81
150	19.85	21.96	33.57	26.21	1.03	0.79	200	29.60	14.08	2.60
200	19.83	22.20	29.35	26.33	1.04	0.76	300	29.32	14.15	2.63
300	19.76	21.99	27.45	27.56	1.03	0.77	400	29.34	14.20	2.57
400	19.73	21.87	25.89	27.49	1.03	0.78	500	29.10	14.12	2.65
500	19.69	22.05	24.58	26.99	1.04	0.76	600	29.14	14.03	2.59
600	19.68	22.08	22.25	26.84	1.04	0.76	700	29.50	13.91	2.71
700	19.57	22.13	21.76	26.63	1.04	0.75	800	30.11	13.71	2.60
800	19.52	22.00	20.44	26.13	1.04	0.76	900	29.89	13.63	2.65
1000	19.42	22.15	18.74	25.36	1.04	0.74	1000	29.36	13.59	2.52
1200	19.27	22.25	17.48	23.31	1.05	0.72	1100	29.79	13.76	2.58
1400	19.11	22.32	16.45	21.93	1.06	0.70	1200	29.89	13.69	2.56
1600	18.94	22.54	15.66	20.72	1.08	0.68	1300	29.72	13.59	2.59
1800	18.77	22.56	14.79	19.13	1.08	0.67	1400	29.42	13.66	2.57
2000	18.60	22.68	13.95	18.12	1.09	0.65	1500	29.40	13.41	2.60
2200	18.39	22.76	13.50	17.40	1.10	0.63	1600	29.79	13.60	2.63
2400	18.28	23.01	13.02	16.56	1.12	0.61	1700	30.33	13.23	2.48
2600	18.04	23.10	12.14	15.80	1.13	0.60	1800	30.11	13.56	2.56
2800	17.86	23.42	11.99	15.30	1.16	0.57	1900	29.63	13.52	2.54
3000	17.73	23.42	11.47	15.02	1.17	0.56	2000	29.31	13.42	2.59
3200	17.49	23.68	11.20	15.11	1.20	0.53	2100	29.05	13.23	2.54
3400	17.48	23.82	10.83	14.69	1.21	0.53	2200	28.71	12.90	2.51
3600	17.37	24.05	10.48	14.36	1.22	0.51	2300	28.60	12.73	2.50
3800	17.24	24.19	10.26	14.37	1.24	0.50	2400	28.30	12.74	2.51
4000	17.19	24.44	10.38	14.46	1.27	0.48	2500	27.97	12.91	2.53
4200	17.13	24.60	10.00	14.50	1.28	0.47	2600	27.83	12.75	2.63
4400	17.13	24.74	10.09	13.80	1.28	0.46	2700	27.50	12.76	2.52
4600	17.02	24.76	10.22	13.91	1.30	0.45	2800	27.29	12.82	2.63
5000	17.06	25.16	10.20	12.98	1.32	0.43	2900	27.01	12.78	2.54
5500	17.02	24.99	11.39	10.90	1.28	0.42	3000	26.64	12.64	2.63
6000	17.18	24.80	12.43	9.31	1.21	0.43	3100	26.29	12.21	2.53
6500	17.68	24.79	13.69	7.57	1.11	0.45	3200	25.85	12.48	2.62
7000	17.70	24.65	20.01	5.48	1.00	0.44	3300	25.45	12.44	2.67
7500	17.21	24.22	39.18	4.32	0.93	0.45	3400	24.98	12.45	2.68
8000	15.57	24.25	18.49	4.13	1.01	0.38	3500	24.80	12.10	2.61
8500	13.30	23.00	15.38	5.02	1.17	0.33	3600	24.62	11.99	2.68
9000	11.25	23.94	13.87	5.52	1.62	0.27	3700	24.35	12.13	2.55
9500	9.41	22.15	11.56	5.36	1.50	0.23	3800	24.20	11.82	2.59
10000	7.64	20.99	10.18	5.77	1.57	0.19	4000	23.59	11.63	2.58

Typical Performance Data

Definitions:

Input Return Loss = -S11 (dB)

Gain(Power Gain) = S21 (dB)

Reverse Isolation = -S12 (dB)

Output Return Loss = -S22 (dB)

TEST CONDITIONS: INPUT POWER = -25dBm, I_{cc} = 32mA, V_d = 4.43V @Temperature = -45degC

FREQ	Gain	Isolation	Input Return Loss	Output Return Loss	Stability		FREQ	IP3 Output	1dB Comp. Output	Noise Figure
(MHz)	(dB)	(dB)	(dB)	(dB)	K	Delta	(MHz)	(dBm)	(dBm)	(dB)
50	19.54	21.83	25.73	22.59	1.03	0.77	50	25.01	11.44	2.72
100	19.49	21.50	32.18	23.52	1.03	0.79	100	24.75	11.04	2.75
150	19.50	21.49	25.80	22.42	1.03	0.80	200	25.35	11.18	2.60
200	19.48	21.74	26.64	22.64	1.03	0.77	300	25.07	11.20	2.58
300	19.40	21.60	25.57	23.08	1.03	0.78	400	25.07	11.21	2.57
400	19.41	21.79	24.88	22.99	1.04	0.76	500	24.86	11.28	2.59
500	19.36	21.67	24.11	22.66	1.03	0.77	600	24.86	11.12	2.59
600	19.36	21.84	21.68	23.10	1.04	0.76	700	25.11	11.06	2.67
700	19.25	21.75	21.74	22.88	1.04	0.75	800	25.55	10.82	2.58
800	19.25	21.83	20.22	23.00	1.04	0.75	900	25.36	10.78	2.59
1000	19.10	22.00	18.70	22.85	1.05	0.72	1000	25.01	10.67	2.50
1200	18.97	21.98	17.59	21.53	1.05	0.72	1100	25.32	10.90	2.58
1400	18.82	22.17	16.44	20.46	1.07	0.69	1200	25.41	10.92	2.54
1600	18.68	22.27	15.75	19.59	1.08	0.68	1300	25.20	10.78	2.57
1800	18.53	22.30	14.78	18.05	1.08	0.67	1400	25.13	10.86	2.55
2000	18.36	22.51	13.90	17.12	1.10	0.65	1500	25.16	10.53	2.59
2200	18.18	22.74	13.44	16.30	1.11	0.62	1600	25.55	10.82	2.60
2400	18.02	22.80	12.92	15.70	1.12	0.61	1700	25.90	10.52	2.48
2600	17.83	23.05	12.07	14.92	1.14	0.59	1800	25.81	10.89	2.53
2800	17.63	23.19	11.89	14.44	1.16	0.57	1900	25.51	10.74	2.54
3000	17.50	23.28	11.37	14.06	1.17	0.56	2000	25.38	10.69	2.54
3200	17.29	23.53	11.08	14.14	1.20	0.54	2100	25.29	10.53	2.55
3400	17.27	23.68	10.66	13.77	1.20	0.53	2200	25.08	10.12	2.46
3600	17.17	23.82	10.32	13.51	1.22	0.52	2300	25.09	10.00	2.48
3800	17.05	24.12	10.11	13.51	1.25	0.50	2400	24.96	9.95	2.51
4000	16.99	24.19	10.26	13.54	1.26	0.49	2500	24.77	10.16	2.52
4200	16.96	24.39	9.85	13.57	1.27	0.47	2600	24.91	10.17	2.60
4400	16.95	24.49	9.92	13.03	1.27	0.47	2700	24.83	10.25	2.51
4600	16.85	24.66	10.18	13.11	1.30	0.45	2800	24.85	10.28	2.60
5000	16.92	25.01	10.11	12.32	1.31	0.43	2900	24.61	10.18	2.53
5500	16.87	24.76	11.35	10.43	1.26	0.43	3000	24.42	10.19	2.60
6000	17.02	24.58	12.33	8.89	1.19	0.43	3100	24.18	9.85	2.53
6500	17.50	24.47	14.15	7.18	1.09	0.45	3200	23.87	10.22	2.60
7000	17.57	24.25	19.47	5.28	0.96	0.44	3300	23.62	10.14	2.65
7500	17.01	24.01	31.64	4.12	0.90	0.44	3400	23.31	10.43	2.67
8000	15.35	23.79	17.97	4.12	0.97	0.38	3500	23.29	10.17	2.59
8500	13.08	22.98	14.98	4.98	1.18	0.32	3600	23.13	10.11	2.65
9000	11.13	24.32	13.29	5.22	1.64	0.26	3700	22.93	10.05	2.52
9500	9.20	21.94	11.29	5.23	1.46	0.22	3800	22.84	9.95	2.59
10000	7.37	20.93	10.07	5.87	1.61	0.19	4000	22.37	10.06	2.57

REV. X1
GALI-33+
080127

Page 5 of 11



IF/RF MICROWAVE COMPONENTS • ISO 9001 ISO 14001 AS 9100 CERTIFIED • RoHS compliant

P.O. Box 350166, Brooklyn, New York 11235-0003 (718) 934-4500 Fax (718) 332-4661



The Design Engineers Search Engine finds the model you need, Instantly • For detailed performance specs & shopping online see



Typical Performance Data

Definitions:

Input Return Loss = -S11 (dB)

Gain(Power Gain) = S21 (dB)

Reverse Isolation = -S12 (dB)

Output Return Loss = -S22 (dB)

TEST CONDITIONS: INPUT POWER = -25dBm, Icc = 48mA, Vd = 4.52V @Temperature = -45degC

FREQ	Gain	Isolation	Input Return Loss	Output Return Loss	Stability		FREQ	IP3 Output	1dB Comp. Output	Noise Figure
(MHz)	(dB)	(dB)	(dB)	(dB)	K	Delta	(MHz)	(dBm)	(dBm)	(dB)
50	20.07	22.19	29.93	29.04	1.03	0.78	50	32.03	16.55	2.77
100	20.02	21.92	32.01	33.74	1.02	0.80	100	31.89	16.19	2.86
150	20.03	22.25	35.78	32.66	1.03	0.77	200	33.45	16.39	2.62
200	20.01	22.09	28.84	32.16	1.03	0.79	300	33.11	16.35	2.68
300	19.94	22.10	26.71	32.86	1.03	0.78	400	33.12	16.37	2.57
400	19.94	22.16	25.64	32.06	1.03	0.78	500	33.05	16.36	2.68
500	19.87	22.13	23.93	30.61	1.03	0.77	600	33.13	16.21	2.61
600	19.88	22.16	21.91	30.28	1.03	0.77	700	33.76	16.12	2.75
700	19.76	22.25	21.43	29.19	1.04	0.75	800	34.70	15.89	2.62
800	19.73	22.20	20.24	27.98	1.04	0.76	900	34.45	15.74	2.67
1000	19.58	22.36	18.55	26.47	1.05	0.73	1000	33.42	15.70	2.54
1200	19.44	22.40	17.36	24.26	1.05	0.72	1100	34.31	15.83	2.62
1400	19.26	22.51	16.29	22.61	1.06	0.70	1200	34.18	15.80	2.58
1600	19.11	22.66	15.57	21.22	1.07	0.68	1300	34.17	15.69	2.63
1800	18.96	22.74	14.71	19.72	1.08	0.67	1400	33.36	15.74	2.61
2000	18.76	22.91	13.94	18.66	1.10	0.64	1500	33.18	15.49	2.63
2200	18.56	22.98	13.47	17.92	1.11	0.63	1600	33.45	15.57	2.67
2400	18.42	23.08	13.14	17.16	1.12	0.61	1700	34.44	15.26	2.51
2600	18.19	23.27	12.23	16.38	1.14	0.59	1800	34.16	15.52	2.60
2800	18.03	23.28	12.14	16.02	1.15	0.58	1900	33.17	15.48	2.57
3000	17.88	23.58	11.69	15.69	1.17	0.56	2000	32.60	15.30	2.64
3200	17.65	23.83	11.34	15.70	1.20	0.53	2100	32.06	15.11	2.58
3400	17.62	24.10	10.95	15.28	1.22	0.52	2200	31.45	14.82	2.55
3600	17.51	24.13	10.62	14.95	1.22	0.51	2300	31.26	14.68	2.54
3800	17.38	24.40	10.39	14.89	1.25	0.49	2400	30.72	14.57	2.59
4000	17.31	24.33	10.54	15.00	1.25	0.48	2500	30.08	14.59	2.57
4200	17.25	24.69	10.10	15.07	1.28	0.46	2600	29.66	14.43	2.67
4400	17.25	24.90	10.17	14.34	1.29	0.45	2700	29.16	14.39	2.57
4600	17.14	24.93	10.27	14.41	1.31	0.44	2800	28.81	14.33	2.68
5000	17.16	25.22	10.24	13.40	1.32	0.43	2900	28.31	14.15	2.57
5500	17.12	25.09	11.45	11.24	1.29	0.42	3000	27.91	13.95	2.68
6000	17.30	25.04	12.31	9.56	1.23	0.43	3100	27.44	13.29	2.58
6500	17.82	25.03	13.61	7.72	1.13	0.45	3200	26.92	13.64	2.67
7000	17.85	24.94	19.64	5.60	1.02	0.44	3300	26.39	13.52	2.72
7500	17.39	24.47	35.02	4.37	0.95	0.45	3400	25.90	13.43	2.73
8000	15.83	24.49	19.01	4.18	1.02	0.39	3500	25.69	13.11	2.65
8500	13.54	23.19	15.76	5.06	1.18	0.34	3600	25.41	12.87	2.72
9000	11.50	24.07	14.11	5.55	1.61	0.28	3700	25.11	13.14	2.57
9500	9.63	22.27	11.81	5.44	1.50	0.23	3800	24.92	12.74	2.62
10000	7.82	20.94	10.34	5.79	1.55	0.20	4000	24.27	12.41	2.62

Typical Performance Data

Definitions:

Input Return Loss = -S11 (dB)

Gain(Power Gain) = S21 (dB)

Reverse Isolation = -S12 (dB)

Output Return Loss = -S22 (dB)

TEST CONDITIONS: INPUT POWER = -25dBm, Icc = 40mA, Vd = 4.07V @Temperature = +85degC

FREQ	Gain	Isolation	Input Return Loss	Output Return Loss	Stability		FREQ	IP3 Output	1dB Comp. Output	Noise Figure
(MHz)	(dB)	(dB)	(dB)	(dB)	K	Delta	(MHz)	(dBm)	(dBm)	(dB)
50	19.75	21.99	29.01	24.71	1.03	0.77	50	28.09	14.57	3.46
100	19.71	22.08	37.55	26.13	1.04	0.76	100	27.79	14.23	3.63
150	19.75	22.41	30.17	25.85	1.05	0.74	200	28.60	14.53	3.44
200	19.70	21.70	28.57	25.90	1.02	0.80	300	28.03	14.42	3.57
300	19.62	21.97	27.06	25.54	1.04	0.76	400	27.85	14.48	3.47
400	19.60	21.92	25.48	25.21	1.03	0.77	500	27.42	14.46	3.59
500	19.55	22.04	23.96	24.90	1.04	0.75	600	27.32	14.35	3.54
600	19.53	21.99	21.82	24.76	1.04	0.76	700	27.52	14.19	3.68
700	19.42	22.16	21.37	24.30	1.05	0.73	800	28.00	13.88	3.55
800	19.39	22.29	20.04	23.98	1.05	0.72	900	27.83	13.85	3.61
1000	19.25	22.19	18.48	23.36	1.05	0.72	1000	27.24	13.74	3.49
1200	19.11	22.28	17.35	22.06	1.06	0.70	1100	27.58	13.86	3.56
1400	18.95	22.42	16.24	20.84	1.07	0.68	1200	27.60	13.69	3.54
1600	18.76	22.51	15.26	19.75	1.08	0.67	1300	27.26	13.63	3.56
1800	18.60	22.70	14.55	18.55	1.10	0.65	1400	26.99	13.69	3.60
2000	18.45	22.88	13.78	17.64	1.11	0.63	1500	26.78	13.48	3.60
2200	18.23	22.97	13.13	16.67	1.12	0.61	1600	27.13	13.57	3.64
2400	18.07	23.16	12.59	15.85	1.14	0.59	1700	27.53	13.24	3.52
2600	17.87	23.38	11.87	15.32	1.16	0.57	1800	27.24	13.51	3.56
2800	17.67	23.53	11.69	14.79	1.18	0.55	1900	26.62	13.34	3.59
3000	17.57	23.65	11.27	14.38	1.19	0.54	2000	26.31	13.26	3.60
3200	17.31	24.00	10.86	14.42	1.23	0.51	2100	26.01	13.05	3.57
3400	17.27	23.86	10.58	14.06	1.22	0.52	2200	25.69	12.66	3.54
3600	17.17	24.17	10.26	13.76	1.24	0.50	2300	25.53	12.57	3.52
3800	17.04	24.31	10.12	13.64	1.26	0.48	2400	25.17	12.44	3.60
4000	16.97	24.32	10.00	13.74	1.26	0.47	2500	24.67	12.61	3.58
4200	16.90	24.54	9.90	13.87	1.28	0.46	2600	24.46	12.30	3.67
4400	16.87	24.57	10.01	13.62	1.29	0.45	2700	24.03	12.21	3.58
4600	16.84	24.85	10.10	13.70	1.31	0.43	2800	23.76	12.20	3.65
5000	16.81	24.84	10.89	12.81	1.31	0.41	2900	23.39	12.03	3.61
5500	16.74	24.64	12.86	10.80	1.27	0.40	3000	23.17	11.89	3.64
6000	16.69	24.36	15.71	9.08	1.21	0.39	3100	22.83	11.19	3.63
6500	16.56	24.25	18.52	7.64	1.15	0.37	3200	22.54	11.65	3.72
7000	16.28	23.67	21.15	6.72	1.10	0.40	3300	22.26	11.39	3.70
7500	14.65	23.85	15.53	6.51	1.23	0.32	3400	21.94	11.34	3.79
8000	12.59	24.37	12.85	6.20	1.52	0.28	3500	21.93	10.93	3.69
8500	10.35	24.32	10.79	5.87	1.78	0.24	3600	21.80	10.56	3.78
9000	8.14	23.44	9.94	6.12	2.03	0.21	3700	21.60	10.57	3.65
9500	6.30	22.95	9.09	6.17	2.26	0.17	3800	21.52	10.02	3.67
10000	4.79	21.91	8.48	5.99	2.26	0.15	4000	20.90	9.61	3.66

Typical Performance Data

Definitions:

Input Return Loss = -S11 (dB)

Gain(Power Gain) = S21 (dB)

Reverse Isolation = -S12 (dB)

Output Return Loss = -S22 (dB)

TEST CONDITIONS: INPUT POWER = -25dBm, Icc = 32mA, Vd = 4.02V @Temperature = +85degC

FREQ	Gain	Isolation	Input Return Loss	Output Return Loss	Stability		FREQ	IP3 Output	1dB Comp. Output	Noise Figure
(MHz)	(dB)	(dB)	(dB)	(dB)	K	Delta	(MHz)	(dBm)	(dBm)	(dB)
50	19.34	21.89	25.22	19.29	1.04	0.75	50	24.64	11.87	3.45
100	19.31	21.84	27.89	21.38	1.04	0.75	100	24.38	11.39	3.56
150	19.31	21.63	24.15	21.12	1.03	0.77	200	24.95	11.64	3.46
200	19.30	21.72	25.23	21.20	1.04	0.76	300	24.48	11.61	3.50
300	19.19	21.90	24.33	21.33	1.05	0.74	400	24.37	11.59	3.49
400	19.19	21.84	22.97	21.05	1.04	0.74	500	24.00	11.68	3.55
500	19.12	21.64	22.48	20.88	1.04	0.75	600	23.94	11.42	3.52
600	19.11	21.78	20.72	21.01	1.04	0.74	700	24.12	11.44	3.64
700	19.00	21.92	20.61	20.84	1.05	0.72	800	24.58	10.99	3.53
800	19.00	21.79	19.38	20.34	1.05	0.73	900	24.38	11.10	3.56
1000	18.90	21.83	18.12	20.38	1.05	0.72	1000	23.91	10.95	3.46
1200	18.76	22.03	17.07	19.53	1.06	0.70	1100	24.23	11.19	3.52
1400	18.58	22.22	16.02	18.69	1.08	0.68	1200	24.28	11.04	3.53
1600	18.42	22.23	15.02	17.68	1.08	0.67	1300	24.04	10.95	3.54
1800	18.29	22.43	14.32	16.71	1.10	0.65	1400	23.85	11.06	3.56
2000	18.11	22.54	13.56	15.99	1.11	0.63	1500	23.83	10.71	3.57
2200	17.93	22.58	13.00	15.25	1.12	0.62	1600	24.14	10.93	3.59
2400	17.78	22.78	12.36	14.59	1.13	0.60	1700	24.51	10.62	3.50
2600	17.57	23.26	11.65	14.12	1.17	0.57	1800	24.31	10.99	3.50
2800	17.40	23.20	11.42	13.55	1.17	0.56	1900	23.92	10.88	3.57
3000	17.26	23.52	10.98	13.23	1.20	0.54	2000	23.69	10.81	3.56
3200	17.07	23.62	10.62	13.21	1.21	0.53	2100	23.49	10.58	3.54
3400	17.02	23.68	10.29	12.91	1.21	0.52	2200	23.24	10.05	3.49
3600	16.94	23.95	10.00	12.55	1.23	0.50	2300	23.20	10.16	3.51
3800	16.80	24.03	9.88	12.45	1.24	0.49	2400	22.94	10.00	3.55
4000	16.74	24.14	9.76	12.68	1.25	0.48	2500	22.61	10.31	3.56
4200	16.68	24.29	9.65	12.75	1.27	0.46	2600	22.60	10.08	3.61
4400	16.66	24.35	9.68	12.60	1.26	0.45	2700	22.32	10.16	3.54
4600	16.64	24.62	9.81	12.57	1.29	0.44	2800	22.16	10.24	3.62
5000	16.64	24.49	10.59	11.84	1.27	0.42	2900	21.83	10.16	3.55
5500	16.58	24.43	12.55	10.15	1.25	0.40	3000	21.68	10.08	3.55
6000	16.51	23.95	15.12	8.54	1.16	0.40	3100	21.36	9.48	3.61
6500	16.40	23.78	17.32	7.18	1.09	0.37	3200	21.14	10.04	3.68
7000	16.07	23.36	19.26	6.40	1.05	0.39	3300	20.93	10.00	3.67
7500	14.41	23.46	14.84	6.27	1.18	0.32	3400	20.66	10.05	3.74
8000	12.37	23.97	12.53	6.03	1.46	0.27	3500	20.66	9.63	3.66
8500	10.13	23.96	10.61	5.73	1.72	0.23	3600	20.54	9.42	3.74
9000	7.91	23.23	9.82	5.98	2.00	0.20	3700	20.33	9.45	3.59
9500	6.09	22.79	9.00	6.05	2.24	0.17	3800	20.23	8.97	3.64
10000	4.55	21.76	8.36	5.90	2.25	0.15	4000	19.64	8.70	3.63

REV. X1
GALI-33+
080127

Page 8 of 11



IF/RF MICROWAVE COMPONENTS • ISO 9001 ISO 14001 AS 9100 CERTIFIED • RoHS compliant

P.O. Box 350166, Brooklyn, New York 11235-0003 (718) 934-4500 Fax (718) 332-4661



The Design Engineers Search Engine finds the model you need, Instantly • For detailed performance specs & shopping online see



Typical Performance Data

Definitions:

Input Return Loss = -S11 (dB)

Gain(Power Gain) = S21 (dB)

Reverse Isolation = -S12 (dB)

Output Return Loss = -S22 (dB)

TEST CONDITIONS: INPUT POWER = -25dBm, Icc = 48mA, Vd = 4.11V @Temperature = +85degC

FREQ	Gain	Isolation	Input Return Loss	Output Return Loss	Stability		FREQ	IP3 Output	1dB Comp. Output	Noise Figure
(MHz)	(dB)	(dB)	(dB)	(dB)	K	Delta	(MHz)	(dBm)	(dBm)	(dB)
50	19.99	22.61	30.00	29.06	1.04	0.74	50	30.88	16.64	3.48
100	19.97	22.16	33.33	31.62	1.03	0.78	100	30.70	16.35	3.67
150	19.99	22.38	34.75	29.70	1.04	0.76	200	31.62	16.52	3.48
200	19.97	22.24	28.66	30.83	1.03	0.77	300	31.01	16.44	3.60
300	19.87	22.25	27.15	30.84	1.04	0.76	400	30.72	16.45	3.48
400	19.87	22.41	25.74	29.41	1.04	0.75	500	30.23	16.42	3.64
500	19.79	22.25	24.22	28.71	1.04	0.75	600	30.10	16.30	3.53
600	19.78	22.22	21.91	28.29	1.04	0.76	700	30.27	16.17	3.73
700	19.66	22.30	21.49	27.53	1.04	0.74	800	30.81	15.95	3.57
800	19.62	22.31	20.11	26.53	1.04	0.74	900	30.60	15.90	3.62
1000	19.48	22.42	18.45	25.51	1.05	0.72	1000	29.80	15.80	3.48
1200	19.32	22.42	17.41	23.80	1.06	0.71	1100	30.27	15.79	3.58
1400	19.18	22.67	16.28	22.23	1.07	0.68	1200	30.18	15.70	3.58
1600	18.97	22.69	15.31	20.84	1.08	0.67	1300	29.75	15.56	3.60
1800	18.83	22.79	14.63	19.58	1.09	0.65	1400	29.26	15.58	3.60
2000	18.63	22.93	13.93	18.56	1.10	0.63	1500	29.00	15.30	3.59
2200	18.42	23.20	13.34	17.63	1.13	0.60	1600	29.34	15.35	3.66
2400	18.26	23.28	12.84	16.71	1.14	0.59	1700	29.83	15.01	3.52
2600	18.04	23.43	12.06	16.14	1.16	0.57	1800	29.31	15.18	3.59
2800	17.85	23.60	11.87	15.52	1.18	0.55	1900	28.57	15.02	3.59
3000	17.75	23.78	11.44	15.16	1.19	0.54	2000	28.17	14.91	3.64
3200	17.49	23.94	11.04	15.14	1.22	0.52	2100	27.74	14.72	3.60
3400	17.45	24.01	10.74	14.78	1.22	0.51	2200	27.34	14.45	3.59
3600	17.33	24.38	10.46	14.43	1.25	0.49	2300	27.12	14.21	3.54
3800	17.20	24.37	10.29	14.32	1.26	0.48	2400	26.62	13.88	3.65
4000	17.12	24.40	10.21	14.39	1.26	0.47	2500	26.12	13.98	3.59
4200	17.07	24.73	10.11	14.57	1.29	0.45	2600	25.71	13.53	3.71
4400	17.01	24.73	10.18	14.32	1.30	0.45	2700	25.22	13.31	3.61
4600	16.99	24.84	10.24	14.30	1.30	0.43	2800	24.86	13.23	3.70
5000	16.94	25.21	11.01	13.35	1.34	0.40	2900	24.50	13.02	3.63
5500	16.88	24.97	13.08	11.23	1.31	0.40	3000	24.23	12.81	3.66
6000	16.84	24.71	16.01	9.36	1.25	0.39	3100	23.90	12.06	3.65
6500	16.75	24.50	19.48	7.79	1.17	0.37	3200	23.57	12.41	3.73
7000	16.52	23.82	22.98	6.85	1.11	0.41	3300	23.27	12.18	3.75
7500	14.87	24.18	16.19	6.61	1.26	0.32	3400	22.97	12.07	3.79
8000	12.81	24.56	13.08	6.20	1.53	0.28	3500	22.96	11.64	3.72
8500	10.58	24.58	10.88	5.89	1.80	0.24	3600	22.84	11.34	3.81
9000	8.36	23.62	10.01	6.09	2.02	0.21	3700	22.66	11.32	3.68
9500	6.51	23.09	9.21	6.18	2.26	0.18	3800	22.66	10.70	3.69
10000	5.00	21.98	8.58	6.05	2.25	0.16	4000	21.99	10.14	3.67

Typical Performance Curves

GAIN vs. TEMPERATURE

INPUT POWER = -25dBm, CURRENT = 40mA

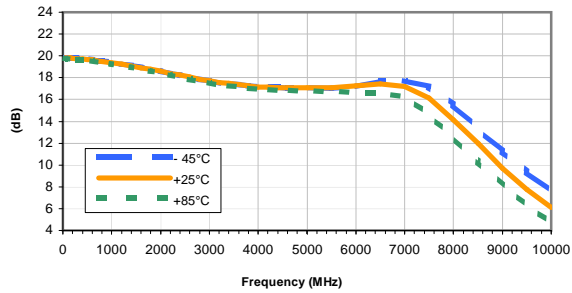

GAIN vs. CURRENT

INPUT POWER = -25dBm, Temperature = +25°C

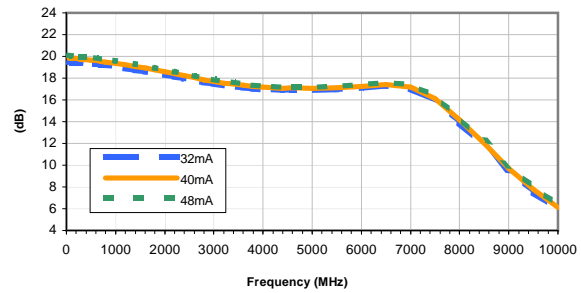

ISOLATION vs. TEMPERATURE

INPUT POWER = -25dBm, CURRENT = 40mA

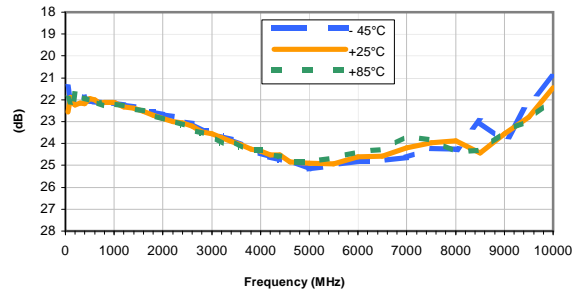

ISOLATION vs. CURRENT

INPUT POWER = -25dBm, Temperature = +25°C

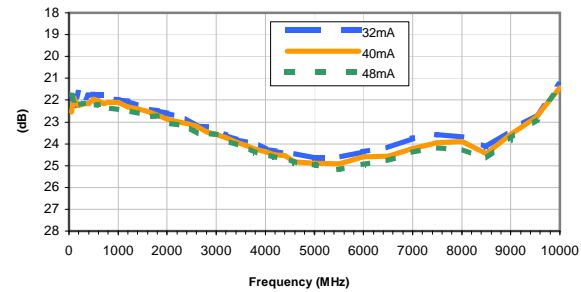

INPUT RETURN LOSS vs. TEMPERATURE

INPUT POWER = -25dBm, CURRENT = 40mA

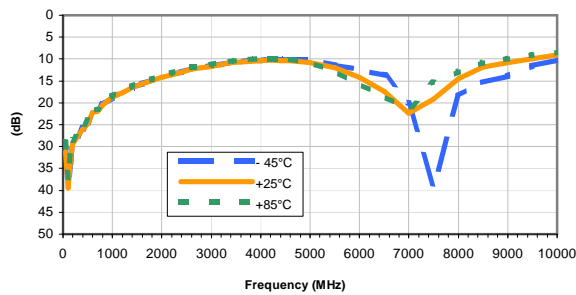

INPUT RETURN LOSS vs. CURRENT

INPUT POWER = -25dBm, Temperature = +25°C

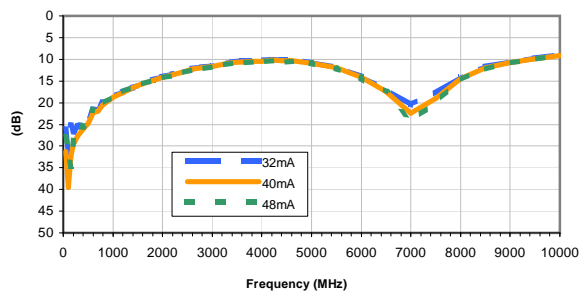

OUTPUT RETURN LOSS vs. TEMPERATURE

INPUT POWER = -25dBm, CURRENT = 40mA

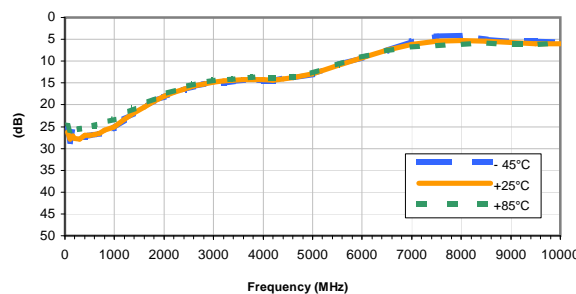

OUTPUT RETURN LOSS vs. CURRENT

INPUT POWER = -25dBm, Temperature = +25°C

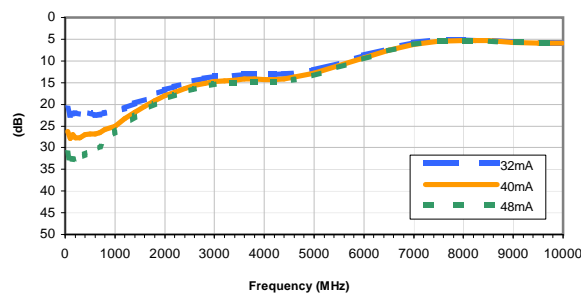

Typical Performance Curves

OUTPUT IP3 vs. TEMPERATURE

INPUT POWER = -25dBm, CURRENT = 40mA

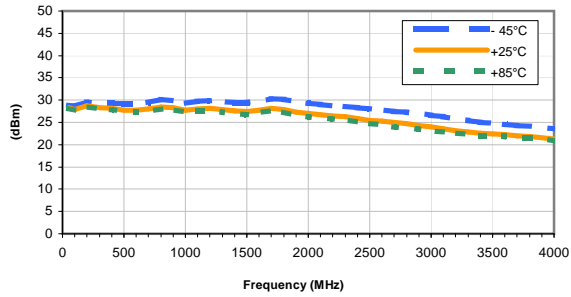

OUTPUT IP3 vs. CURRENT

INPUT POWER = -25dBm, Temperature = +25°C

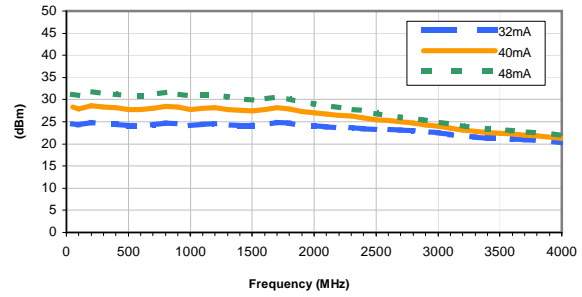

OUTPUT POWER at 1dB Compression vs. TEMPERATURE

CURRENT = 40mA

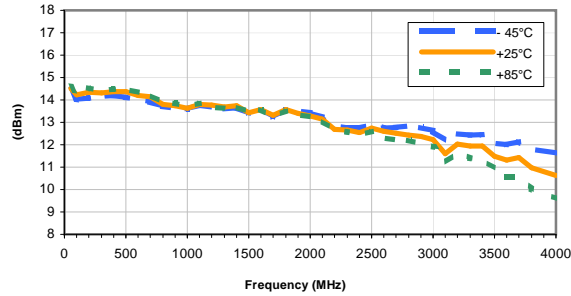

OUTPUT POWER at 1dB Compression vs. CURRENT

Temperature = +25°C

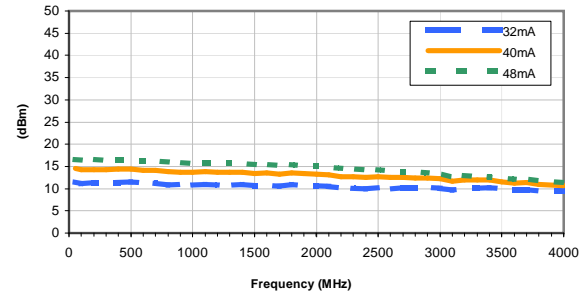

Noise Figure vs. TEMPERATURE

CURRENT = 40mA

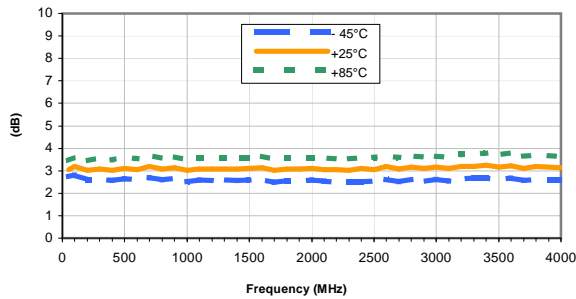

Noise Figure vs. CURRENT

Temperature = +25°C

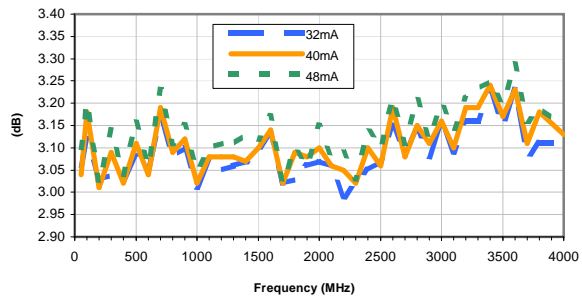

IF/RF MICROWAVE COMPONENTS • ISO 9001 ISO 14001 AS 9100 CERTIFIED RoHS compliant
 P.O. Box 350166, Brooklyn, New York 11235-0003 (718) 934-4500 Fax (718) 332-4661



The Design Engineers Search Engine finds the model you need, Instantly • For detailed performance specs & shopping online see



Typical Performance Curves

GAIN vs. TEMPERATURE

INPUT POWER = -25dBm, CURRENT = 40mA

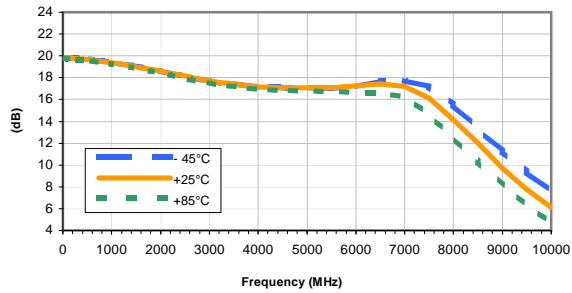

GAIN vs. CURRENT

INPUT POWER = -25dBm, Temperature = +25°C

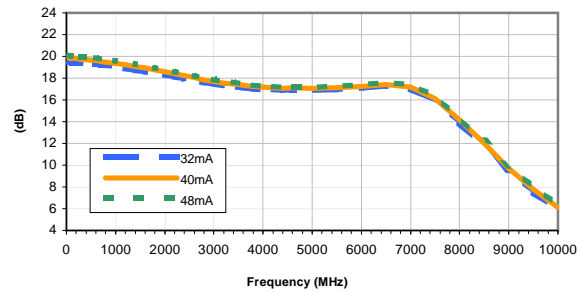

ISOLATION vs. TEMPERATURE

INPUT POWER = -25dBm, CURRENT = 40mA

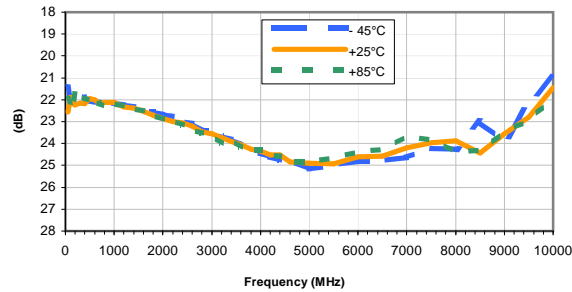

ISOLATION vs. CURRENT

INPUT POWER = -25dBm, Temperature = +25°C

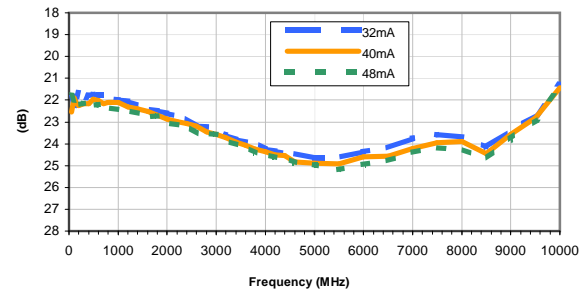

INPUT RETURN LOSS vs. TEMPERATURE

INPUT POWER = -25dBm, CURRENT = 40mA

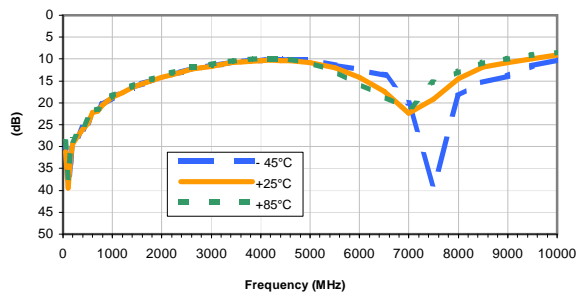

INPUT RETURN LOSS vs. CURRENT

INPUT POWER = -25dBm, Temperature = +25°C

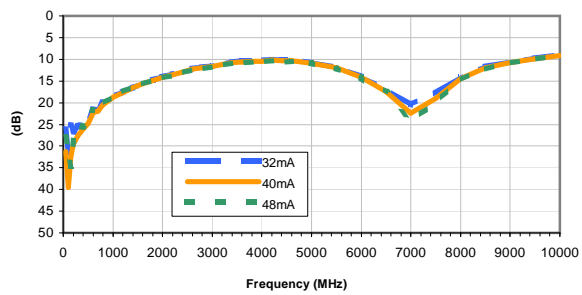

OUTPUT RETURN LOSS vs. TEMPERATURE

INPUT POWER = -25dBm, CURRENT = 40mA

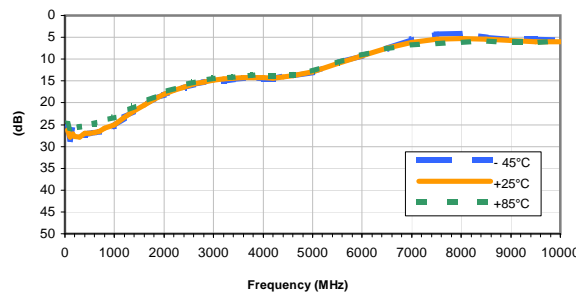

OUTPUT RETURN LOSS vs. CURRENT

INPUT POWER = -25dBm, Temperature = +25°C

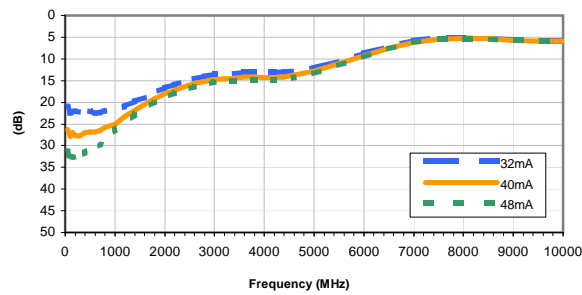

Typical Performance Curves

OUTPUT IP3 vs. TEMPERATURE

INPUT POWER = -25dBm, CURRENT = 40mA

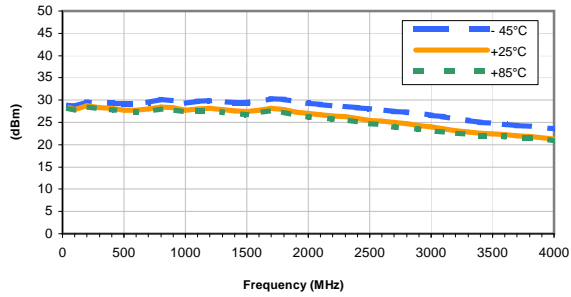

OUTPUT IP3 vs. CURRENT

INPUT POWER = -25dBm, Temperature = +25°C

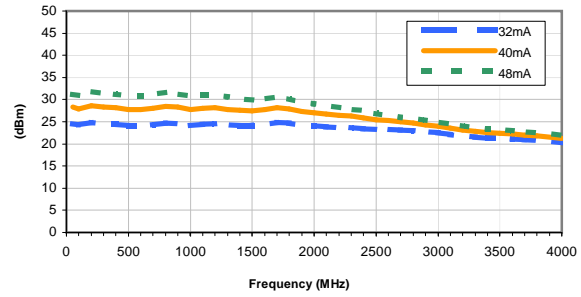

OUTPUT POWER at 1dB Compression vs. TEMPERATURE

CURRENT = 40mA

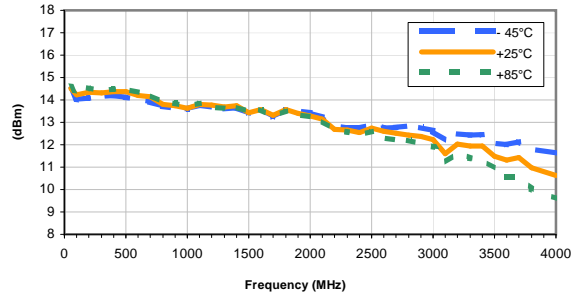

OUTPUT POWER at 1dB Compression vs. CURRENT

Temperature = +25°C

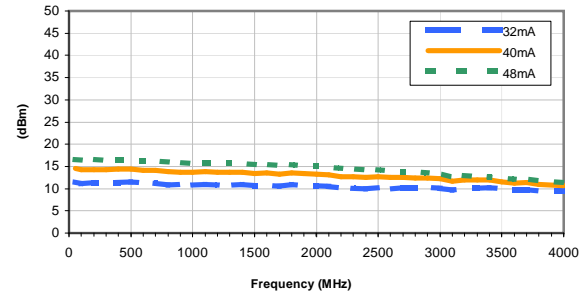

Noise Figure vs. TEMPERATURE

CURRENT = 40mA

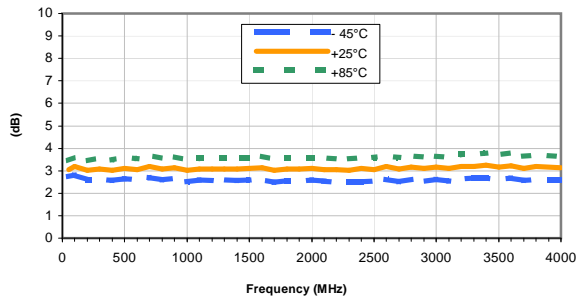

Noise Figure vs. CURRENT

Temperature = +25°C

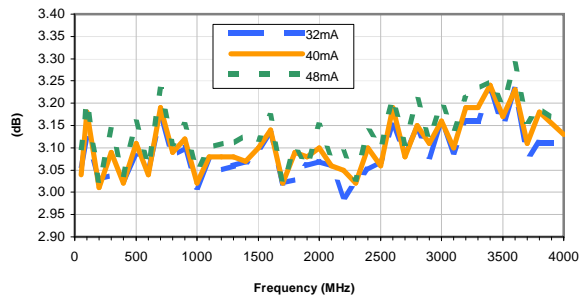

IF/RF MICROWAVE COMPONENTS • ISO 9001 ISO 14001 AS 9100 CERTIFIED RoHS compliant
 P.O. Box 350166, Brooklyn, New York 11235-0003 (718) 934-4500 Fax (718) 332-4661



The Design Engineers Search Engine finds the model you need, Instantly • For detailed performance specs & shopping online see



Outline Dimensions

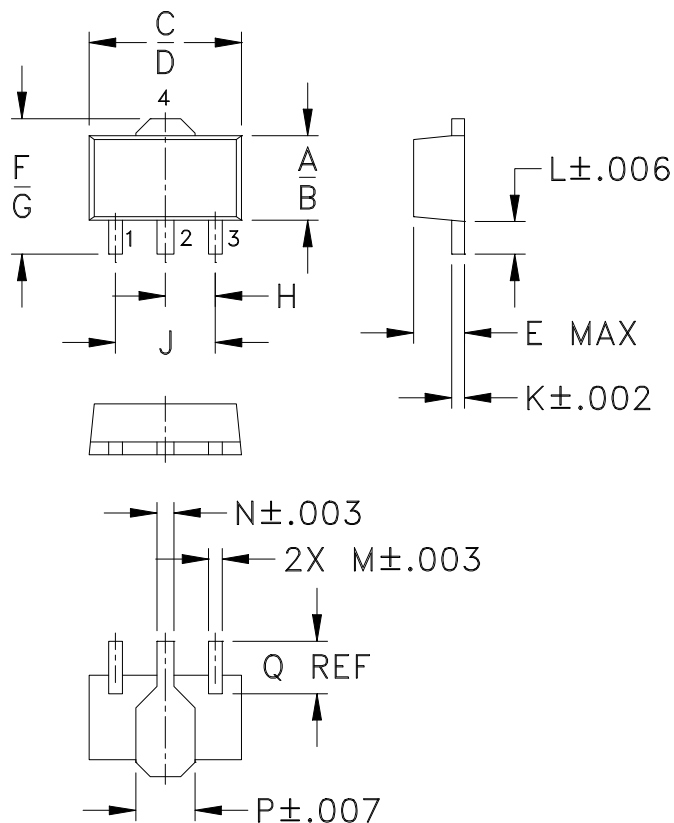

PCB Land Pattern

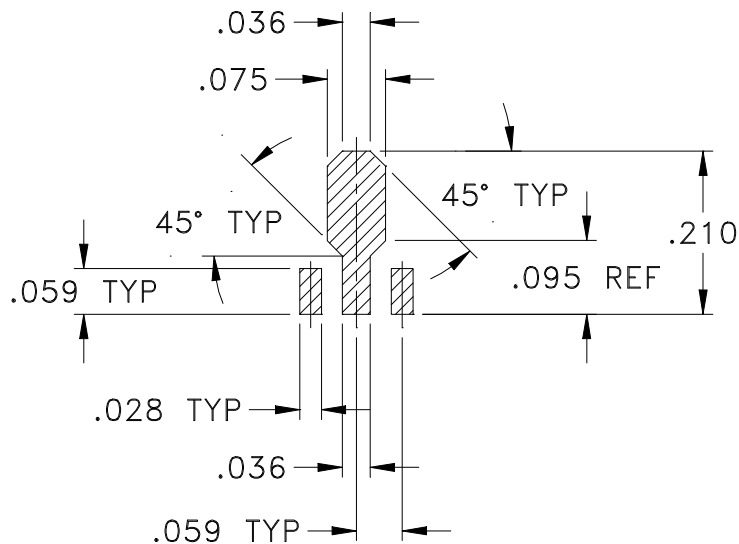

Suggested Layout,
Tolerance to be within $\pm .002$

CASE #	A	B	C	D	E	F	G	H	J	K	L	M
DF782	.102 (2.59)	.090 (2.29)	.181 (4.60)	.173 (4.39)	.063 (1.60)	.167 (4.24)	.155 (3.94)	.059 (1.50)	.118 (3.00)	.015 (0.38)	.041 (1.04)	.016 (0.41)

CASE #	N	P	Q	WT. GRAM
DF782	.019 (0.48)	.065 (1.65)	.062 (1.57)	.2

Dimensions are in inches (mm). Tolerances: 2 Pl. $\pm .01$; 3Pl. $\pm .005$

Notes:

- Case material: Plastic.
- Termination finish:
For RoHS Case Styles: Tin-Silver alloy plate over Nickel barrier or Matte-Tin.
All models, (+) suffix. See model Data sheet.
For RoHS-5 Case Styles: Tin-Lead plate. All models, no (+) suffix.



INTERNET <http://www.minicircuits.com>

P.O. Box 350166, Brooklyn, New York 11235-0003 (718) 934-4500 Fax (718) 332-4661

Distribution Centers NORTH AMERICA 800-654-7949 • 417-335-5935 • Fax 417-335-5945 • EUROPE 44-1252-832600 • Fax 44-1252-837010

Mini-Circuits ISO 9001 & ISO 14001 Certified

Tape & Reel Packaging TR-F55

DEVICE ORIENTATION IN T&R

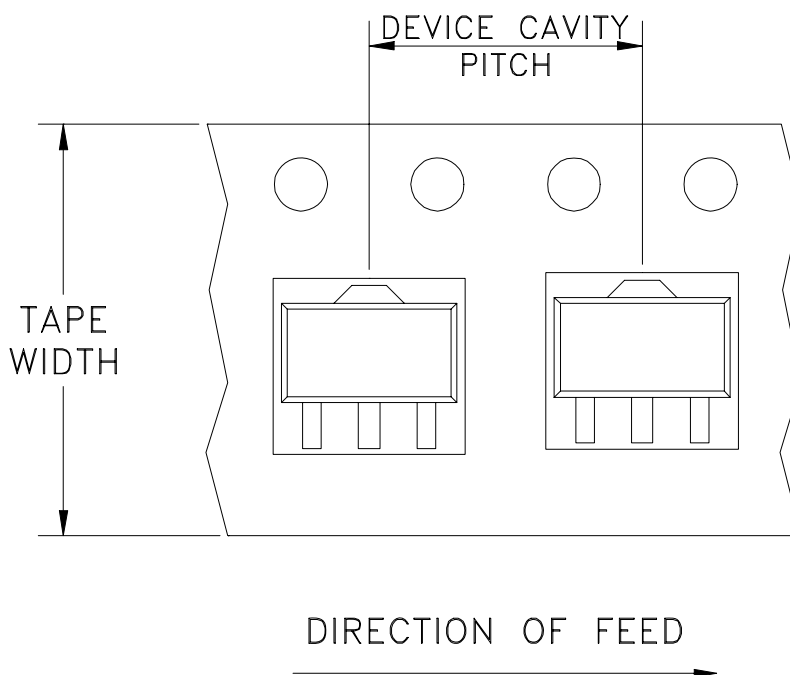

Tape Width, mm	Device Cavity Pitch, mm	Reel Size, inches	Devices per Reel	
12	8	7	Small quantity standard (see note)	20
				50
				100
				200
				500
			Standard	1000

Note: Please consult individual model data sheet to determine device per reel availability.

Mini-Circuits carrier tape materials provide protection from ESD (Electro-Static Discharge) during handling and transportation. Tapes are static dissipative and comply with industry standards EIA-481/EIA-541.

Go to: www.minicircuits.com/pages/pdfs/tape.pdf



INTERNET <http://www.minicircuits.com>

P.O. Box 350166, Brooklyn, New York 11235-0003 (718) 934-4500 Fax (718) 332-4661

Distribution Centers NORTH AMERICA 800-654-7949 • 417-335-5935 • Fax 417-335-5945 • EUROPE 44-1252-832600 • Fax 44-1252-837010

Mini-Circuits ISO 9001 & ISO 14001 Certified

THIRD ANGLE PROJECTION

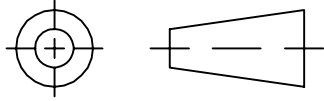

REVISIONS

REV	ECN No.	DESCRIPTION	DATE	DR	AUTH
A	M76190	CHANGED DISCRIPTION	04/01	GF	CT
B	M82575	UPDATED DRAWING	08/05/02	AV	LC
C	M102713	ADDED NOTE 2 & "...WITH SMOBC"	01/17/06	MMG	IL
D	M108434	UPDATED DRAWING PER TB-409+	11/14/06	PW	IG

SUGGESTED MOUNTING CONFIGURATION
FOR DF782 CASE STYLE, "mz" PIN CONNECTION

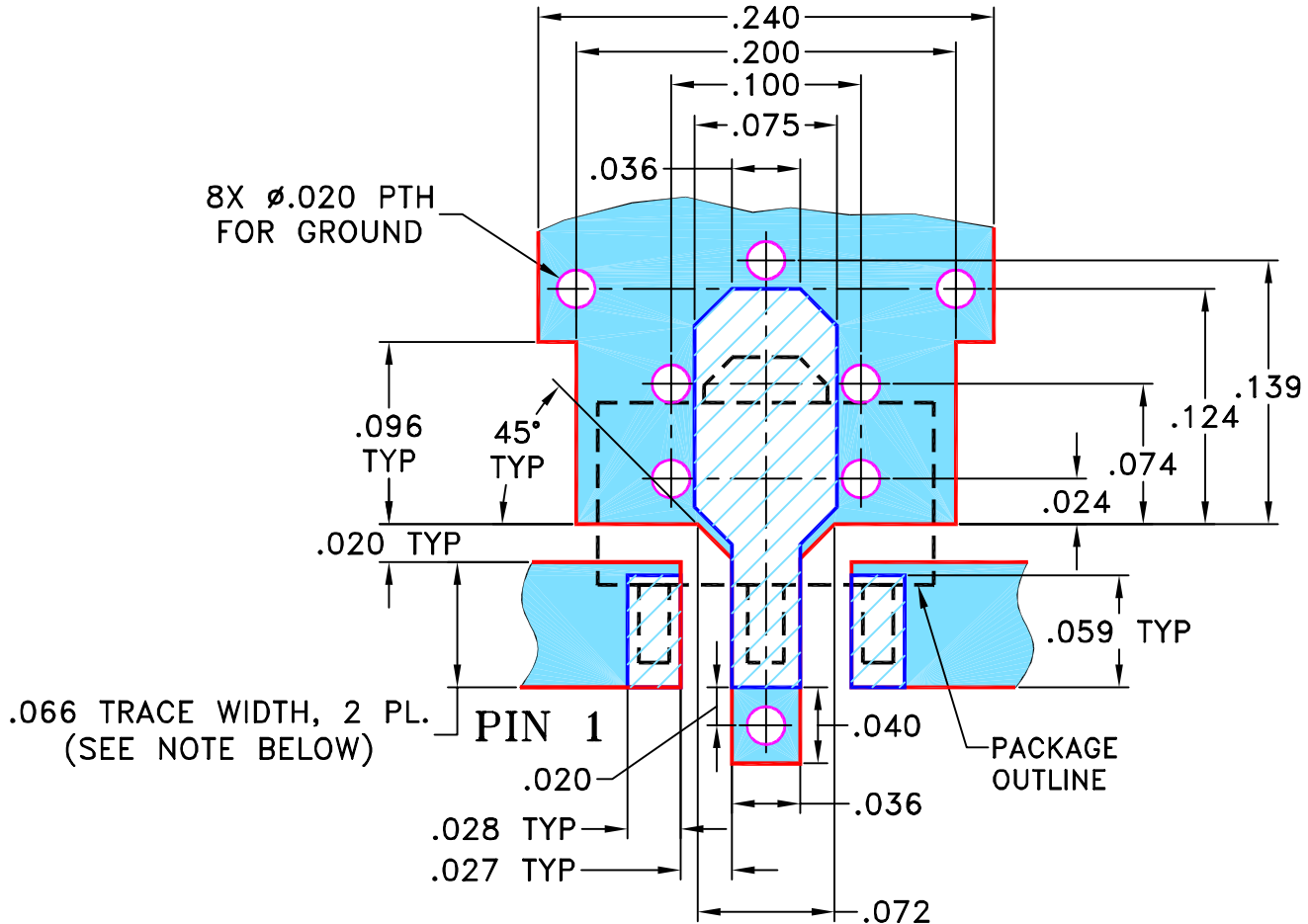

- NOTES:** 1. TRACE WIDTH IS SHOWN FOR ROGERS R04350B WITH DIELECTRIC THICKNESS .030" ± .002"; COPPER: 1/2 OZ. EACH SIDE. FOR OTHER MATERIALS TRACE WIDTH MAY NEED TO BE MODIFIED.
2. BOTTOM SIDE OF THE PCB IS CONTINUOUS GROUND PLANE.



DENOTES PCB COPPER LAYOUT WITH SMOBC (SOLDER MASK OVER BARE COPPER)



DENOTES COPPER LAND PATTERN FREE OF SOLDER MASK

UNLESS OTHERWISE SPECIFIED	INITIALS	DATE
DIMENSIONS ARE IN INCHES	DRAWN AV	01/15/01
TOLERANCES ON:	CHECKED YB	01/23/01
2 PL DECIMALS ±	APPROVED DB	01/23/01
3 PL DECIMALS ± .005		
ANGLES ±		
FRACTIONS ±		



Mini-Circuits®

13 Neptune Avenue
Brooklyn NY 11235

PL, mz, DF782, GALI, TB-409-XXX+

Mini-Circuits®
THIS DOCUMENT AND ITS CONTENTS ARE THE PROPERTY OF MINI-CIRCUITS. EXCEPT FOR USE EXPRESSLY GRANTED, IN WRITING, TO ITS VENDORS, VENDEE AND THE UNITED STATES GOVERNMENT, MINI-CIRCUITS RESERVES ALL PROPRIETARY DESIGN, USE, MANUFACTURING AND REPRODUCTION RIGHTS THERETO. THESE CONTENTS SHALL NOT BE USED, DUPLICATED OR DISCLOSED TO ANY OUTSIDE PARTY, IN WHOLE OR IN PART, WITHOUT WRITTEN PERMISSION OF MINI-CIRCUITS.

SIZE	CODE IDENT	DRAWING NO:	REV:
A	15542	98-PL-019	D
FILE:	98PL019	SCALE: 10:1	SHEET: 1 OF 1

Evaluation Board and Circuit

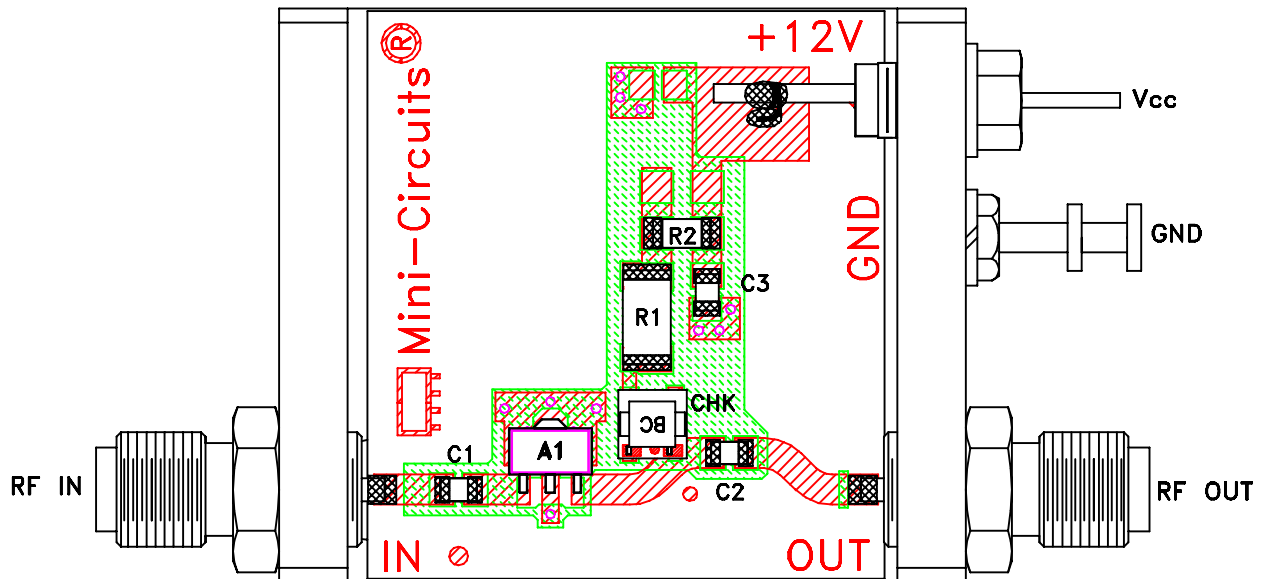

TB-409-33+

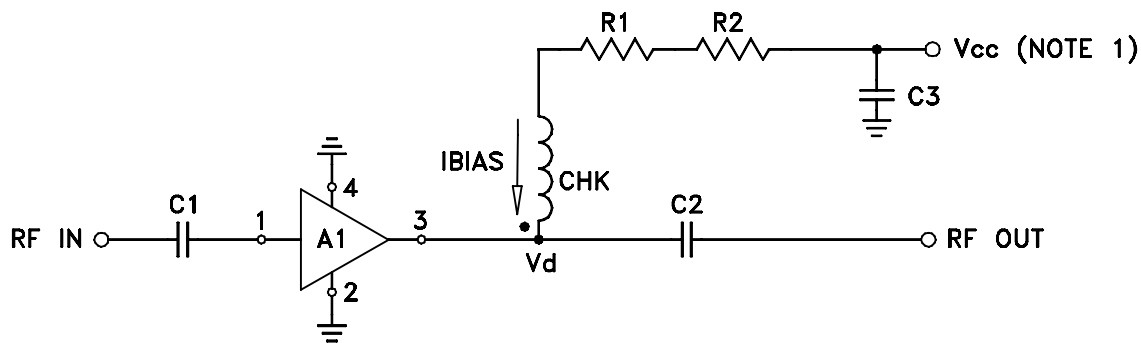

COMPONENT	VALUE
A1	Gali-33(+)
C1 (NOTE 4)	2400 pF
C2 (NOTE 4)	2400 pF
C3 (bypass)	0.1 uF
R1	191 Ohms, 0.75W
R2	2.21 Ohms, 0.25W
CHK	Mini-Circuits TCCH-80+

Schematic Diagram

NOTE:

1. Vcc voltage: $+12 \pm 0.2V$.
2. SMA Female connectors.
3. PCB material: Rogers RO4350 or equivalent, dielectric constant=3.5, dielectric thickness=.030 inch.
4. Capacitors, C1 & C2 should be free of resonance up to the highest frequency specified.

 **Mini-Circuits®**

All Mini-Circuits products are manufactured under exacting quality assurance and control standards, and are capable of meeting published specifications after being subjected to any or all of the following physical and environmental test.

Specification	Test/Inspection Condition	Reference/Spec
Operating Temperature	-45° to 85°C or -40° to 85°C Ambient Environment	Individual Model Data Sheet
Storage Temperature	-65° to 150° C Ambient Environment	Individual Model Data Sheet
Thermal Shock	-55° to 100°C, 100 cycles	MIL-STD-202, Method 107, Condition A-3, except +100°C
Mechanical Shock	1.5Kg, 0.5 ms, 5 shock pulses, Y1 direction only	MIL-STD-883, Method 2002, Condition B, except Y1 direction only
Vibration (Variable Frequency)	50g peak	MIL-STD-883, Method 2007, Condition B
Autoclave	15 psig, 100% RH, 121°C, 96 hours	JESD22-A102, Condition C
HAST	130°C, 85% RH, 96 hours	JESD22-A110
Solderability	10X Magnification	J-STD-002, Para 4.2.5, Test S, 95% Coverage
Solder Reflow Heat	Sn-Pb Eutetic Process: 240°C peak Pb-Free Process: 260°C peak	J-STD-020, Table 4-1, 4-2 and 5-2; Figure 5-1
Moisture Sensitivity: Level 1	Bake at 125°C for 24 hours Soak at 85°C/85% RH for 168 hours, Reflow 3 cycles at 260°C peak	J-STD-020
Marking Resistance to Solvents	Isopropyl alcohol + mineral spirits at 25°C; terpene defluxer at 25°C; distilled water + proylene glycol monomethyl ether +	MIL-STD-202, Method 215



All Mini-Circuits products are manufactured under exacting quality assurance and control standards, and are capable of meeting published specifications after being subjected to any or all of the following physical and environmental test.

Specification	Test/Inspection Condition	Reference/Spec
	monoethanolamine at 63°C to 70°C	