

### Product Features

- High gain, 25 dB typ. at 100 MHz
- High IP3, 35 dBm typ.
- High Pout, P1dB 19 dBm typ.
- Internally Matched to 50 Ohms
- Transient protected
- Excellent ESD Protection
- Unconditionally stable
- Aqueous washable
- Protected by US patent 6,943,629

### Typical Applications

- Base station infrastructure
- Portable Wireless
- CATV & DBS
- MMDS & Wireless LAN

### General Description

Gali=24+ (RoHS compliant) is a wideband amplifier offering high dynamic range. It has repeatable performance from lot to lot and is enclosed in a SOT-89 package. It uses patented Transient Protected Darlington configuration and is fabricated using InGaP HBT technology. Expected MTTF is 3,000 years at 85°C case temperature. Gali=24+ is designed to be rugged for ESD and supply switch-on transients.

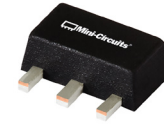

Generic photo used for illustration purposes only

## Gali=24+

CASE STYLE: DF782

#### +RoHS Compliant

The +Suffix identifies RoHS Compliance. See our web site for RoHS Compliance methodologies and qualifications

### simplified schematic and pin description

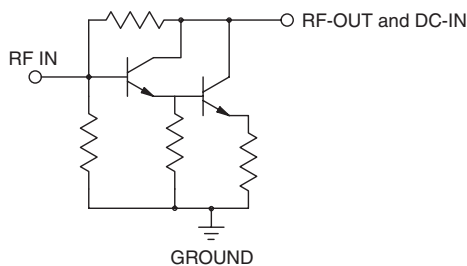

Function	Pin Number	Description
RF IN	1	RF input pin. This pin requires the use of an external DC blocking capacitor chosen for the frequency of operation.
RF-OUT and DC-IN	3	RF output and bias pin. DC voltage is present on this pin; therefore a DC blocking capacitor is necessary for proper operation. An RF choke is needed to feed DC bias without loss of RF signal due to the bias connection, as shown in "Recommended Application Circuit".
GND	2,4	Connections to ground. Use via holes as shown in "Suggested Layout for PCB Design" to reduce ground path inductance for best performance.

#### Notes

- A. Performance and quality attributes and conditions not expressly stated in this specification document are intended to be excluded and do not form a part of this specification document.  
 B. Electrical specifications and performance data contained in this specification document are based on Mini-Circuit's applicable established test performance criteria and measurement instructions.  
 C. The parts covered by this specification document are subject to Mini-Circuits standard limited warranty and terms and conditions (collectively, "Standard Terms"); Purchasers of this part are entitled to the rights and benefits contained therein. For a full statement of the Standard Terms and the exclusive rights and remedies thereunder, please visit Mini-Circuits' website at [www.minicircuits.com/MCLStore/terms.jsp](http://www.minicircuits.com/MCLStore/terms.jsp)



Electrical Specifications at 25°C and 80mA, unless noted

Parameter	Min.	Typ.	Max.	Units	Cpk	
Frequency Range*	DC		6	GHz		
Gain	f=0.1 GHz	24.0	25.3	26.6	dB	≥1.5
	f=1 GHz	—	22.6	—		
	f=2 GHz	18.1	19.1	20.1		
	f=3 GHz	—	16.6	—		
	f=4 GHz	14.2	14.9	15.6		
	f=6 GHz	—	12.4	—		
Magnitude of Gain Variation versus Temperature (values are negative)	f=0.1 GHz	—	0.0021	—	dB/°C	
	f=1 GHz	—	0.0035	—		
	f=2 GHz	—	0.0045	0.0090		
	f=3 GHz	—	0.0056	—		
	f=4 GHz	—	0.0074	—		
	f=6 GHz	—	0.0154	—		
Input Return Loss	f=0.1 GHz	—	21.6	—	dB	
	f=1 GHz	—	20.4	—		
	f=2 GHz	14	17.5	—		
	f=3 GHz	—	15.4	—		
	f=4 GHz	—	14.9	—		
	f=6 GHz	—	19.0	—		
Output Return Loss	f=0.1 GHz	—	18.5	—	dB	
	f=1 GHz	—	11.5	—		
	f=2 GHz	7	9.1	—		
	f=3 GHz	—	8.8	—		
	f=4 GHz	—	8.8	—		
	f=6 GHz	—	7.2	—		
Reverse Isolation	f=2 GHz		26.7		dB	
Output Power @1 dB compression	f=0.1 GHz	18.3	19.3	—	dBm	≥1.5
	f=1 GHz	18.2	19.2	—		
	f=2 GHz	18.4	19.4	—		
	f=3 GHz	—	19.3	—		
	f=4 GHz	—	18.1	—		
	f=6 GHz	—	14.7	—		
Saturated Output Power (at 3dB compression)	f=0.1 GHz		21.1		dBm	
	f=1 GHz		20.9			
	f=2 GHz		21.0			
	f=3 GHz		20.4			
	f=4 GHz		19.1			
	f=6 GHz		16.0			
Output IP3	f=0.1 GHz	30.4	33.8	—	dBm	≥1.5
	f=1 GHz	31.5	35.0	—		
	f=2 GHz	32.7	36.3	—		
	f=3 GHz	—	35.3	—		
	f=4 GHz	—	33.1	—		
	f=6 GHz	—	30.3	—		
Noise Figure	f=0.1 GHz	—	4.2	5.2	dBm	≥1.5
	f=1 GHz	—	4.3	—		
	f=2 GHz	—	4.2	5.2		
	f=3 GHz	—	4.3	—		
	f=4 GHz	—	4.5	5.5		
	f=6 GHz	—	5.3	—		
Group Delay	f=2 GHz		97		psec	
Recommended Device Operating Current			80		mA	
Device Operating Voltage	5.4	5.8	6.2		V	≥1.5
Device Voltage Variation vs. Temperature at 80mA			-3.6		mV/°C	
Device Voltage Variation vs Current at 25°C			3.3		mV/mA	
Thermal Resistance, junction-to-case <sup>1</sup>			64		°C/W	

\*Guaranteed specification DC-6 GHz. Low frequency cut off determined by external coupling capacitors.

Absolute Maximum Ratings

Parameter	Ratings
Operating Temperature*	-45°C to 85°C
Storage Temperature	-65°C to 150°C
Operating Current	160mA
Power Dissipation	1W
Input Power	13 dBm

Note: Permanent damage may occur if any of these limits are exceeded. These ratings are not intended for continuous normal operation.  
<sup>1</sup>Case is defined as ground leads.  
 \*Based on typical case temperature rise 7°C above ambient.

Notes

- A. Performance and quality attributes and conditions not expressly stated in this specification document are intended to be excluded and do not form a part of this specification document.
- B. Electrical specifications and performance data contained in this specification document are based on Mini-Circuit's applicable established test performance criteria and measurement instructions.
- C. The parts covered by this specification document are subject to Mini-Circuits standard limited warranty and terms and conditions (collectively, "Standard Terms"); Purchasers of this part are entitled to the rights and benefits contained therein. For a full statement of the Standard Terms and the exclusive rights and remedies thereunder, please visit Mini-Circuits' website at [www.minicircuits.com/MCLStore/terms.jsp](http://www.minicircuits.com/MCLStore/terms.jsp)



**Product Marking**

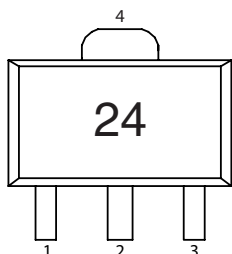

Markings in addition to model number designation may appear for internal quality control purposes.

**Additional Detailed Technical Information**

Additional information is available on our web site. To access this information enter the model number on our web site home page.

**Performance data, graphs, s-parameter data set (.zip file)**

**Case Style: DF782**

Plastic package, exposed paddle, lead finish: Matte-Tin

**Tape & Reel: F55**

7" reels with 20, 50, 100, 200, 500, 1K devices.

**Suggested Layout for PCB Design: PL-019**

**Evaluation Board: TB-409-24+**

**Environmental Ratings: ENV08T2**

**Recommended Application Circuit**

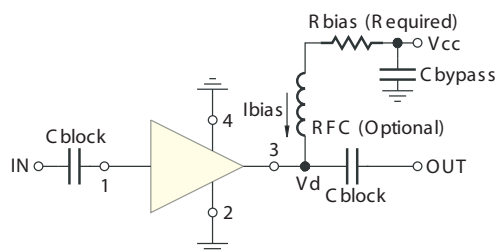

Test Board includes case, connectors, and components (in bold) soldered to PCB

R BIAS	
Vcc	"1%" Res. Values (ohms) for Optimum Biasing
8	28.7
9	41.2
10	53.7
11	66.5
12	78.7
13	90.9
14	105
15	115
16	127
17	140
18	154
19	165
20	178

**Notes**

- A. Performance and quality attributes and conditions not expressly stated in this specification document are intended to be excluded and do not form a part of this specification document.
- B. Electrical specifications and performance data contained in this specification document are based on Mini-Circuit's applicable established test performance criteria and measurement instructions.
- C. The parts covered by this specification document are subject to Mini-Circuits standard limited warranty and terms and conditions (collectively, "Standard Terms"); Purchasers of this part are entitled to the rights and benefits contained therein. For a full statement of the Standard Terms and the exclusive rights and remedies thereunder, please visit Mini-Circuits' website at [www.minicircuits.com/MCLStore/terms.jsp](http://www.minicircuits.com/MCLStore/terms.jsp)



**ESD Rating**

Human Body Model (HBM): Class 1C (1000v to < 2000v) in accordance with ANSI/ESD STM 5.1 - 2001

Machine Model (MM): Class M2 (100v to < 200v) in accordance with ANSI/ESD STM 5.2 - 1999

**MSL Rating**

Moisture Sensitivity: MSL1 in accordance with IPC/JEDECJ-STD-020C

No.	Test Required	Condition	Standard	Quantity
1	Visual Inspection	Low Power Microscope Magnification 40x	MIP-IN-0003 (MCT spec)	45 units
2	Electrical Test	Room Temperature	SCD (MCL spec)	45 units
3	SAM Analysis	Less than 10% growth in term of delamination	J-Std-020C (Jedec Standard)	45 units
4	Moisture Sensitivity Level 1	Bake at 125°C for 24 hours Soak at 85°C/85%RH for 168 hours Reflow 3 cycles at 260°C peak	J-Std-020C (Jedec Standard)	45 units

**MSL Test Flow Chart**

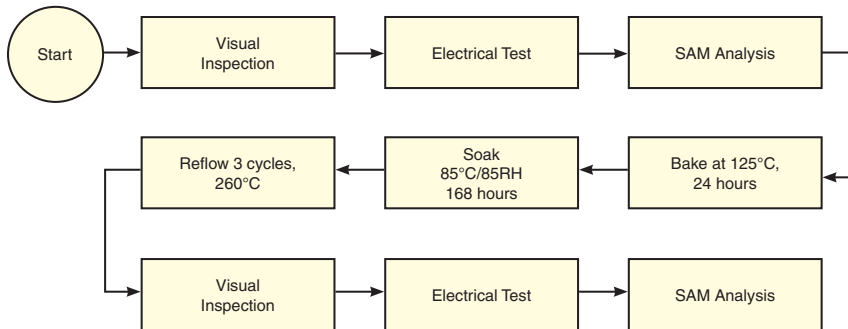

**Notes**

- A. Performance and quality attributes and conditions not expressly stated in this specification document are intended to be excluded and do not form a part of this specification document.
- B. Electrical specifications and performance data contained in this specification document are based on Mini-Circuit's applicable established test performance criteria and measurement instructions.
- C. The parts covered by this specification document are subject to Mini-Circuits standard limited warranty and terms and conditions (collectively, "Standard Terms"); Purchasers of this part are entitled to the rights and benefits contained therein. For a full statement of the Standard Terms and the exclusive rights and remedies thereunder, please visit Mini-Circuits' website at [www.minicircuits.com/MCLStore/terms.jsp](http://www.minicircuits.com/MCLStore/terms.jsp)



## Typical Performance Data

**NOTE: Use PDF Bookmarks to view DATA at required conditions or to view GRAPHS.**

**Definitions:**

Input Return Loss = -S11 (dB)

Gain(Power Gain) = S21 (dB)

Reverse Isolation = -S12 (dB)

Output Return Loss = -S22 (dB)

TEST CONDITIONS: Icc = 80mA, Vd = 5.72V @Temperature = +25degC

FREQ	Gain	Isolation	Input Return Loss	Output Return Loss	Stability		IP3 Output	1dB Comp. Output	FREQ	Noise Figure
(MHz)	(dB)	(dB)	(dB)	(dB)	K	Delta	(dBm)	(dBm)	(MHz)	(dB)
50	25.43	28.60	22.54	18.45	1.04	0.69	33.74	19.42	50	4.09
100	25.36	29.30	22.08	18.12	1.08	0.63	33.65	19.53	100	4.21
200	25.21	29.11	21.97	17.33	1.07	0.63	33.82	19.42	200	4.22
400	24.79	29.15	21.97	15.28	1.09	0.59	33.56	19.32	400	4.39
600	24.16	28.92	21.57	13.49	1.09	0.56	33.52	19.10	600	4.32
800	23.47	28.60	21.25	12.13	1.10	0.53	34.04	19.11	800	4.44
1000	22.74	28.45	20.71	11.12	1.12	0.49	34.30	19.16	1000	4.37
1200	22.00	28.06	20.34	10.37	1.13	0.47	34.25	18.67	1200	4.38
1400	21.28	27.81	19.66	9.82	1.15	0.44	33.98	18.88	1400	4.45
1600	20.59	27.47	19.11	9.45	1.16	0.42	34.26	19.02	1600	4.45
1800	19.92	27.20	18.41	9.16	1.19	0.40	34.73	18.97	1800	4.38
2000	19.34	26.88	17.75	8.96	1.20	0.39	34.43	19.09	2000	4.32
2200	18.75	26.57	17.31	8.89	1.22	0.37	34.32	19.20	2200	4.39
2400	18.23	26.22	16.75	8.86	1.22	0.36	34.01	19.31	2400	4.38
2600	17.77	25.99	16.29	8.87	1.24	0.34	33.81	19.19	2600	4.42
2800	17.34	25.71	15.95	8.95	1.26	0.33	33.62	18.94	2800	4.40
3000	16.96	25.39	15.47	8.96	1.26	0.33	33.54	18.88	3000	4.44
3200	16.56	25.21	15.40	9.12	1.29	0.32	33.22	18.77	3200	4.39
3400	16.27	24.91	15.06	9.20	1.28	0.32	33.00	18.65	3400	4.54
3600	15.96	24.60	14.89	9.22	1.28	0.32	32.56	18.40	3600	4.57
3800	15.64	24.42	14.82	9.31	1.30	0.31	31.76	18.00	3800	4.69
4000	15.37	24.27	14.78	9.32	1.32	0.31	31.26	17.44	4000	4.65
4200	15.07	24.11	14.86	9.31	1.34	0.31	31.00	17.19	4200	4.81
4400	14.79	24.06	14.97	9.22	1.37	0.30	30.88	16.94	4400	4.71
4600	14.53	23.87	15.00	9.03	1.37	0.30	30.43	16.57	4600	4.89
4800	14.20	23.79	15.31	8.80	1.40	0.30	30.20	15.99	4800	4.88
5000	13.99	23.92	15.72	8.75	1.45	0.29	29.98	15.57	5000	5.05
5200	13.71	23.93	15.92	8.50	1.48	0.28	29.64	15.34	5200	5.01
5400	13.40	23.88	16.47	8.25	1.52	0.28	29.29	15.07	5400	5.15
5600	13.16	23.88	17.29	8.16	1.56	0.28	28.87	14.83	5600	5.22
5800	12.83	24.03	17.00	7.98	1.62	0.27	28.72	14.57	5800	5.27
6000	12.47	24.19	16.86	7.85	1.70	0.26	28.55	13.99	6000	5.34
6200	12.11	24.28	16.90	7.73	1.78	0.26	28.54	12.64	6500	5.38
6400	11.75	24.11	17.28	7.85	1.84	0.26	28.22	12.46	7000	5.75
6600	11.24	24.45	16.31	7.71	1.99	0.25	28.06	12.90	7500	5.89
6800	10.74	24.77	14.91	7.39	2.14	0.26	27.75	12.85	8000	6.53
7000	10.15	24.42	14.04	7.47	2.20	0.26	27.71	13.07	8500	7.23
7200	9.45	24.67	12.67	7.29	2.38	0.26	27.19	12.92	9000	7.56
7500	8.31	24.24	11.31	7.22	2.53	0.27	27.63	11.64	9500	8.20
8000	6.44	24.17	9.02	6.67	2.84	0.28	26.29	10.57	10000	8.32

REV. X1  
GALI-24+  
070823

Page 1 of 11



IF/RF MICROWAVE COMPONENTS • ISO 9001 ISO 14001 AS 9100 CERTIFIED • RoHS compliant

P.O. Box 350166, Brooklyn, New York 11235-0003 (718) 934-4500 Fax (718) 332-4661



The Design Engineers Search Engine finds the model you need, Instantly • For detailed performance specs & shopping online see



## Typical Performance Data

### Definitions:

Input Return Loss = -S11 (dB)

Gain(Power Gain) = S21 (dB)

Reverse Isolation = -S12 (dB)

Output Return Loss = -S22 (dB)

TEST CONDITIONS: Icc = 60mA, Vd = 5.66V @Temperature = +25degC

FREQ	Gain	Isolation	Input Return Loss	Output Return Loss	Stability		IP3 Output	1dB Comp. Output	FREQ	Noise Figure
(MHz)	(dB)	(dB)	(dB)	(dB)	K	Delta	(dBm)	(dBm)	(MHz)	(dB)
50	24.80	29.23	17.55	26.86	1.11	0.59	28.69	15.29	50	4.00
100	24.78	28.65	17.79	24.42	1.08	0.63	28.55	15.41	100	4.08
200	24.63	28.39	17.77	21.98	1.07	0.64	28.65	15.32	200	4.19
400	24.23	28.45	18.07	17.49	1.08	0.60	28.41	15.25	400	4.35
600	23.67	28.21	18.01	14.81	1.08	0.57	28.50	15.17	600	4.28
800	23.02	27.90	18.08	12.99	1.08	0.54	29.09	15.18	800	4.38
1000	22.34	27.81	17.86	11.76	1.09	0.50	29.43	15.32	1000	4.31
1200	21.62	27.45	17.70	10.86	1.10	0.47	29.51	14.75	1200	4.31
1400	20.93	27.14	17.44	10.20	1.11	0.45	29.56	15.00	1400	4.39
1600	20.26	26.91	17.12	9.73	1.13	0.42	29.87	15.24	1600	4.37
1800	19.64	26.70	16.64	9.41	1.15	0.40	30.50	15.29	1800	4.27
2000	19.06	26.41	16.07	9.18	1.16	0.38	30.55	15.59	2000	4.24
2200	18.48	26.16	15.76	9.09	1.19	0.36	30.81	15.69	2200	4.29
2400	17.99	25.94	15.31	9.03	1.21	0.35	30.99	15.84	2400	4.28
2600	17.53	25.67	14.84	9.03	1.22	0.33	30.96	15.86	2600	4.30
2800	17.09	25.37	14.64	9.11	1.23	0.33	30.83	15.57	2800	4.28
3000	16.72	25.13	14.24	9.13	1.24	0.32	31.04	15.56	3000	4.28
3200	16.33	25.02	14.20	9.32	1.28	0.31	30.97	15.72	3200	4.26
3400	16.03	24.75	13.87	9.42	1.28	0.30	30.78	15.84	3400	4.42
3600	15.72	24.50	13.78	9.46	1.29	0.30	30.29	15.78	3600	4.44
3800	15.41	24.38	13.75	9.60	1.31	0.30	29.63	15.56	3800	4.56
4000	15.13	24.27	13.77	9.67	1.34	0.29	29.25	15.11	4000	4.46
4200	14.82	24.11	13.83	9.70	1.36	0.29	29.08	15.01	4200	4.65
4400	14.54	24.05	13.98	9.69	1.40	0.28	28.95	14.88	4400	4.55
4600	14.26	23.96	14.04	9.50	1.42	0.28	28.55	14.53	4600	4.70
4800	13.93	23.86	14.33	9.34	1.45	0.28	28.10	14.05	4800	4.71
5000	13.70	24.07	14.74	9.31	1.52	0.27	28.04	13.76	5000	4.87
5200	13.40	24.03	14.90	9.12	1.55	0.26	27.79	13.65	5200	4.83
5400	13.09	24.01	15.46	8.90	1.60	0.26	27.54	13.38	5400	4.97
5600	12.82	24.01	16.21	8.83	1.65	0.26	27.17	13.14	5600	5.06
5800	12.47	24.19	15.98	8.71	1.74	0.25	26.89	12.93	5800	5.10
6000	12.12	24.41	15.99	8.61	1.84	0.24	26.65	12.65	6000	5.15
6200	11.73	24.48	16.02	8.52	1.93	0.24	26.79	11.37	6500	5.16
6400	11.37	24.31	16.45	8.67	1.99	0.24	26.69	11.10	7000	5.52
6600	10.85	24.66	15.64	8.55	2.17	0.23	26.40	11.66	7500	5.65
6800	10.36	25.03	14.46	8.22	2.35	0.23	26.17	11.72	8000	6.26
7000	9.74	24.67	13.69	8.28	2.42	0.24	26.43	12.01	8500	6.95
7200	9.04	24.90	12.40	8.11	2.62	0.24	26.07	11.88	9000	7.30
7500	7.94	24.46	11.13	7.98	2.76	0.25	26.49	10.59	9500	7.95
8000	6.09	24.40	8.92	7.34	3.10	0.26	25.75	9.79	10000	8.00

## Typical Performance Data

### Definitions:

Input Return Loss = -S11 (dB)

Gain(Power Gain) = S21 (dB)

Reverse Isolation = -S12 (dB)

Output Return Loss = -S22 (dB)

TEST CONDITIONS: Icc = 100mA, Vd = 5.76V @Temperature = +25degC

FREQ	Gain	Isolation	Input Return Loss	Output Return Loss	Stability		IP3 Output	1dB Comp. Output	FREQ	Noise Figure
(MHz)	(dB)	(dB)	(dB)	(dB)	K	Delta	(dBm)	(dBm)	(MHz)	(dB)
50	25.68	29.60	25.63	16.34	1.08	0.63	37.33	21.73	50	4.07
100	25.65	29.87	25.32	16.02	1.09	0.61	37.35	21.81	100	4.22
200	25.50	29.53	25.84	15.53	1.08	0.62	37.59	21.65	200	4.23
400	25.06	29.43	24.81	14.14	1.08	0.59	36.96	21.53	400	4.30
600	24.43	29.26	24.03	12.67	1.09	0.56	36.51	21.71	600	4.30
800	23.72	28.96	23.13	11.58	1.10	0.53	36.72	21.51	800	4.47
1000	22.96	28.77	22.21	10.75	1.13	0.49	36.70	21.39	1000	4.38
1200	22.19	28.44	21.48	10.12	1.14	0.47	36.39	21.46	1200	4.41
1400	21.46	28.09	20.67	9.64	1.16	0.45	35.91	21.36	1400	4.32
1600	20.75	27.73	19.97	9.30	1.18	0.42	36.09	21.34	1600	4.48
1800	20.07	27.41	19.43	9.03	1.20	0.40	36.24	21.40	1800	4.52
2000	19.46	27.07	18.68	8.85	1.21	0.39	35.92	21.17	2000	4.33
2200	18.89	26.79	18.20	8.85	1.23	0.37	35.42	21.00	2200	4.38
2400	18.36	26.45	17.70	8.85	1.25	0.36	35.24	21.03	2400	4.47
2600	17.89	26.08	16.97	8.85	1.25	0.35	34.65	21.06	2600	4.45
2800	17.40	25.99	16.97	9.01	1.30	0.33	34.65	20.98	2800	4.41
3000	17.05	25.49	16.23	8.95	1.27	0.33	34.51	20.96	3000	4.39
3200	16.67	25.22	16.01	9.06	1.28	0.33	34.19	20.98	3200	4.47
3400	16.33	25.01	15.79	9.17	1.30	0.32	33.98	20.90	3400	4.55
3600	16.02	24.75	15.62	9.20	1.30	0.32	33.51	20.81	3600	4.64
3800	15.72	24.53	15.57	9.25	1.31	0.32	32.65	20.64	3800	4.60
4000	15.47	24.41	15.49	9.28	1.33	0.31	32.13	20.41	4000	4.64
4200	15.17	24.26	15.84	9.21	1.35	0.31	31.94	20.08	4200	4.69
4400	14.88	24.15	16.00	9.15	1.37	0.30	31.76	19.79	4400	4.74
4600	14.68	23.97	15.99	9.00	1.37	0.31	31.27	19.50	4600	4.89
4800	14.40	23.95	16.10	8.73	1.40	0.30	30.95	19.03	4800	4.98
5000	14.17	23.94	16.57	8.56	1.43	0.30	30.70	18.40	5000	5.02
5200	13.93	23.94	16.58	8.37	1.45	0.29	30.48	18.01	5200	5.02
5400	13.64	23.86	16.60	8.08	1.47	0.29	29.92	17.78	5400	5.12
5600	13.38	23.91	17.32	7.97	1.52	0.28	29.61	17.37	5600	5.14
5800	13.05	23.96	17.37	7.75	1.57	0.28	29.44	16.84	5800	5.35
6000	12.69	24.02	17.45	7.64	1.63	0.27	29.38	16.42	6000	5.27
6200	12.30	24.06	17.54	7.52	1.70	0.27	29.32	16.14	6500	5.31
6400	11.84	24.16	16.99	7.38	1.79	0.27	29.21	15.88	7000	5.60
6600	11.39	24.04	16.66	7.35	1.86	0.27	29.00	15.61	7500	5.55
6800	10.78	24.21	15.47	7.24	2.00	0.26	28.85	14.72	8000	6.10
7000	10.15	24.45	14.06	7.05	2.16	0.26	28.62	13.61	8500	6.96
7200	9.49	24.35	12.81	6.98	2.26	0.27	28.77	13.32	9000	7.07
7500	8.43	24.43	11.12	6.71	2.47	0.27	28.03	12.56	9500	8.39
8000	6.56	23.93	9.04	6.40	2.69	0.29	26.61	11.02	10000	8.77

REV. X1  
GALI-24+  
070823

Page 3 of 11



IF/RF MICROWAVE COMPONENTS • ISO 9001 ISO 14001 AS 9100 CERTIFIED • RoHS compliant

P.O. Box 350166, Brooklyn, New York 11235-0003 (718) 934-4500 Fax (718) 332-4661



The Design Engineers Search Engine finds the model you need, Instantly • For detailed performance specs & shopping online see



## Typical Performance Data

### Definitions:

Input Return Loss = -S11 (dB)

Gain(Power Gain) = S21 (dB)

Reverse Isolation = -S12 (dB)

Output Return Loss = -S22 (dB)

TEST CONDITIONS: Icc = 80mA, Vd = 6.01V @Temperature = -45degC

FREQ	Gain	Isolation	Input Return Loss	Output Return Loss	Stability		IP3 Output	1dB Comp. Output	FREQ	Noise Figure
(MHz)	(dB)	(dB)	(dB)	(dB)	K	Delta	(dBm)	(dBm)	(MHz)	(dB)
50	25.59	28.77	21.83	18.18	1.04	0.68	33.93	19.08	50	3.63
100	25.52	29.31	21.51	18.21	1.07	0.64	33.65	19.07	100	3.71
200	25.38	29.22	21.34	17.60	1.07	0.63	33.73	18.88	200	3.76
400	24.99	29.36	22.77	14.85	1.09	0.59	33.91	19.03	400	3.88
600	24.40	28.96	22.19	13.35	1.08	0.57	34.04	18.83	600	3.80
800	23.72	28.72	21.55	12.01	1.09	0.54	34.70	18.89	800	3.91
1000	23.00	28.43	21.29	11.14	1.10	0.51	35.08	18.91	1000	3.83
1200	22.28	28.12	20.87	10.39	1.12	0.49	35.26	18.51	1200	3.83
1400	21.57	27.82	20.37	9.80	1.13	0.46	35.33	18.63	1400	3.88
1600	20.87	27.51	19.81	9.41	1.15	0.44	35.66	18.80	1600	3.88
1800	20.23	27.29	19.31	9.13	1.17	0.42	36.63	18.83	1800	3.77
2000	19.65	26.87	18.62	8.89	1.17	0.41	36.78	19.00	2000	3.74
2200	19.08	26.63	18.37	8.79	1.20	0.39	37.15	19.11	2200	3.77
2400	18.57	26.26	17.87	8.72	1.20	0.38	37.50	19.39	2400	3.78
2600	18.10	26.09	17.41	8.81	1.23	0.36	37.85	19.32	2600	3.78
2800	17.70	25.73	17.02	8.81	1.23	0.36	37.80	19.14	2800	3.75
3000	17.35	25.32	16.48	8.78	1.21	0.35	38.13	19.19	3000	3.80
3200	17.02	25.08	16.42	8.97	1.23	0.35	38.32	19.26	3200	3.73
3400	16.70	24.89	16.09	8.92	1.24	0.34	38.28	19.29	3400	3.87
3600	16.43	24.57	15.73	9.07	1.24	0.34	38.09	19.46	3600	3.86
3800	16.14	24.41	15.57	9.22	1.25	0.34	36.82	19.12	3800	3.97
4000	15.89	24.25	15.43	9.16	1.26	0.33	35.78	18.78	4000	3.91
4200	15.63	23.99	15.36	8.97	1.25	0.34	35.71	18.68	4200	4.10
4400	15.34	23.87	15.42	8.70	1.26	0.33	36.18	18.46	4400	3.96
4600	15.12	23.81	15.89	8.46	1.28	0.33	35.75	18.14	4600	4.11
4800	14.84	23.68	16.11	8.25	1.29	0.33	35.61	17.75	4800	4.05
5000	14.66	23.68	16.21	7.97	1.30	0.32	35.10	17.41	5000	4.22
5200	14.43	23.76	16.77	7.79	1.33	0.31	34.79	17.15	5200	4.21
5400	14.22	23.76	17.26	7.60	1.35	0.31	34.92	16.84	5400	4.35
5600	14.03	23.66	18.75	7.42	1.37	0.31	33.92	16.66	5600	4.38
5800	13.75	23.59	18.60	7.28	1.40	0.32	33.41	16.43	5800	4.44
6000	13.52	23.76	18.43	7.15	1.44	0.31	33.70	15.90	6000	4.45
6200	13.26	23.75	18.56	7.05	1.48	0.31	33.47	14.48	6500	4.49
6400	13.01	23.60	18.74	7.11	1.51	0.31	33.87	14.06	7000	4.84
6600	12.55	23.97	16.68	6.75	1.61	0.31	33.44	14.40	7500	4.93
6800	12.09	24.37	15.10	6.29	1.71	0.31	32.86	14.27	8000	5.61
7000	11.51	24.38	14.00	6.23	1.80	0.31	32.71	14.48	8500	6.14
7200	10.90	24.21	13.03	6.11	1.87	0.32	32.52	14.24	9000	6.48
7500	9.63	23.23	12.07	6.30	1.93	0.32	32.70	13.02	9500	7.13
8000	7.85	23.13	9.35	5.87	2.12	0.32	31.21	12.90	10000	7.08



## Typical Performance Data

### Definitions:

Input Return Loss = -S11 (dB)

Gain(Power Gain) = S21 (dB)

Reverse Isolation = -S12 (dB)

Output Return Loss = -S22 (dB)

TEST CONDITIONS: Icc = 60mA, Vd = 5.94V @Temperature = -45degC

FREQ	Gain	Isolation	Input Return Loss	Output Return Loss	Stability		IP3 Output	1dB Comp. Output	FREQ	Noise Figure
(MHz)	(dB)	(dB)	(dB)	(dB)	K	Delta	(dBm)	(dBm)	(MHz)	(dB)
50	25.06	28.57	18.12	24.03	1.06	0.66	27.93	14.68	50	3.56
100	24.98	28.73	17.71	23.55	1.07	0.64	27.66	14.77	100	3.62
200	24.88	28.63	17.63	22.12	1.07	0.64	27.68	14.49	200	3.73
400	24.51	28.76	18.80	17.11	1.08	0.60	27.90	14.64	400	3.86
600	23.94	28.28	18.63	14.60	1.07	0.59	28.13	14.56	600	3.78
800	23.30	28.11	18.58	12.86	1.07	0.55	28.83	14.64	800	3.87
1000	22.64	27.92	18.66	11.76	1.09	0.51	29.16	14.72	1000	3.81
1200	21.96	27.57	18.61	10.89	1.09	0.49	29.35	14.22	1200	3.79
1400	21.25	27.28	18.29	10.16	1.11	0.46	29.57	14.40	1400	3.84
1600	20.60	27.02	17.83	9.73	1.12	0.44	29.86	14.55	1600	3.83
1800	19.96	26.75	17.55	9.36	1.14	0.42	30.49	14.71	1800	3.72
2000	19.43	26.51	17.01	9.11	1.15	0.40	30.70	14.88	2000	3.68
2200	18.86	26.26	16.77	8.99	1.17	0.38	31.19	15.02	2200	3.70
2400	18.34	26.00	16.35	8.89	1.19	0.37	31.65	15.41	2400	3.67
2600	17.90	25.78	16.00	8.97	1.21	0.35	32.05	15.35	2600	3.68
2800	17.49	25.49	15.60	8.97	1.21	0.35	32.03	15.09	2800	3.67
3000	17.14	25.12	15.15	8.92	1.20	0.34	32.53	15.24	3000	3.68
3200	16.80	24.97	15.08	9.13	1.23	0.33	33.01	15.34	3200	3.64
3400	16.51	24.72	14.88	9.11	1.23	0.33	33.20	15.65	3400	3.76
3600	16.23	24.50	14.54	9.28	1.24	0.33	32.80	15.99	3600	3.75
3800	15.92	24.32	14.44	9.45	1.26	0.32	32.13	15.70	3800	3.87
4000	15.70	24.17	14.37	9.46	1.27	0.32	31.72	15.45	4000	3.79
4200	15.43	23.94	14.29	9.30	1.27	0.32	31.82	15.69	4200	3.99
4400	15.14	23.87	14.42	9.07	1.29	0.32	31.94	15.67	4400	3.85
4600	14.90	23.83	14.84	8.84	1.30	0.31	31.34	15.34	4600	3.99
4800	14.63	23.75	15.08	8.69	1.33	0.31	30.90	14.82	4800	3.94
5000	14.42	23.77	15.21	8.40	1.34	0.30	30.52	14.73	5000	4.12
5200	14.19	23.81	15.72	8.28	1.38	0.30	30.63	14.71	5200	4.10
5400	13.96	23.87	16.19	8.09	1.42	0.29	30.60	14.38	5400	4.24
5600	13.73	23.79	17.45	7.94	1.44	0.29	30.04	14.17	5600	4.28
5800	13.47	23.70	17.41	7.88	1.47	0.30	29.73	13.98	5800	4.30
6000	13.20	23.90	17.28	7.75	1.53	0.29	29.34	13.79	6000	4.32
6200	12.95	23.96	17.44	7.75	1.59	0.29	29.11	12.37	6500	4.35
6400	12.65	23.75	17.60	7.81	1.62	0.29	29.35	12.01	7000	4.69
6600	12.20	24.13	15.97	7.48	1.74	0.29	29.02	12.56	7500	4.75
6800	11.73	24.57	14.64	6.97	1.86	0.29	29.00	12.50	8000	5.41
7000	11.14	24.61	13.61	6.91	1.97	0.29	28.70	12.87	8500	5.94
7200	10.53	24.41	12.76	6.84	2.04	0.30	28.29	12.57	9000	6.25
7500	9.27	23.41	11.83	6.92	2.09	0.30	29.05	11.14	9500	6.91
8000	7.49	23.26	9.21	6.42	2.28	0.30	29.24	11.64	10000	6.77

## Typical Performance Data

### Definitions:

Input Return Loss = -S11 (dB)

Gain(Power Gain) = S21 (dB)

Reverse Isolation = -S12 (dB)

Output Return Loss = -S22 (dB)

TEST CONDITIONS: Icc = 100mA, Vd = 6.03V @Temperature = -45degC

FREQ	Gain	Isolation	Input Return Loss	Output Return Loss	Stability		IP3 Output	1dB Comp. Output	FREQ	Noise Figure
(MHz)	(dB)	(dB)	(dB)	(dB)	K	Delta	(dBm)	(dBm)	(MHz)	(dB)
50	25.81	29.75	25.09	16.07	1.07	0.63	37.88	21.80	50	3.65
100	25.78	29.62	24.31	16.12	1.07	0.63	37.67	21.91	100	3.81
200	25.64	29.74	23.99	15.98	1.08	0.61	37.77	21.65	200	3.80
400	25.22	29.48	25.86	13.79	1.08	0.60	37.69	21.56	400	3.87
600	24.61	29.32	24.36	12.60	1.09	0.57	37.56	21.85	600	3.85
800	23.93	29.02	23.39	11.57	1.10	0.54	38.00	21.65	800	3.98
1000	23.20	28.72	22.60	10.88	1.11	0.51	38.36	21.54	1000	3.90
1200	22.44	28.44	22.20	10.21	1.13	0.48	38.39	21.62	1200	3.91
1400	21.72	28.09	21.50	9.61	1.14	0.46	38.26	21.57	1400	3.82
1600	21.02	27.79	20.63	9.29	1.16	0.44	38.68	21.50	1600	3.98
1800	20.36	27.43	20.14	9.00	1.18	0.42	39.96	21.56	1800	4.04
2000	19.76	27.08	19.50	8.82	1.19	0.41	40.16	21.33	2000	3.80
2200	19.19	26.80	19.05	8.77	1.21	0.39	40.22	21.15	2200	3.82
2400	18.67	26.53	18.66	8.75	1.23	0.38	40.36	21.16	2400	3.92
2600	18.21	26.10	17.78	8.73	1.22	0.37	39.93	21.27	2600	3.88
2800	17.74	25.96	17.74	8.85	1.26	0.35	40.07	21.19	2800	3.85
3000	17.40	25.44	17.07	8.81	1.23	0.36	40.53	21.27	3000	3.80
3200	17.06	25.25	16.90	8.92	1.25	0.35	40.68	21.50	3200	3.91
3400	16.73	24.98	16.66	9.07	1.26	0.34	40.90	21.59	3400	3.96
3600	16.43	24.73	16.52	9.00	1.26	0.34	39.77	21.50	3600	4.01
3800	16.17	24.51	16.48	9.10	1.27	0.34	38.27	21.41	3800	3.96
4000	15.94	24.35	16.71	9.11	1.28	0.34	36.92	21.34	4000	4.02
4200	15.68	24.20	17.18	8.95	1.29	0.34	37.85	21.24	4200	4.07
4400	15.42	24.01	17.42	8.74	1.29	0.34	38.86	21.14	4400	4.08
4600	15.26	23.98	17.09	8.58	1.30	0.33	37.94	21.06	4600	4.26
4800	15.03	23.79	17.22	8.24	1.29	0.33	37.78	20.75	4800	4.28
5000	14.84	23.81	17.61	8.01	1.31	0.33	37.09	20.28	5000	4.32
5200	14.66	23.73	17.36	7.82	1.31	0.32	37.47	19.92	5200	4.30
5400	14.46	23.73	17.40	7.52	1.32	0.32	37.24	19.59	5400	4.43
5600	14.25	23.71	17.81	7.45	1.34	0.32	36.27	19.28	5600	4.39
5800	14.02	23.66	18.26	7.29	1.36	0.31	36.45	18.88	5800	4.61
6000	13.75	23.72	18.49	7.06	1.39	0.31	36.22	18.47	6000	4.49
6200	13.44	23.68	18.66	6.89	1.43	0.31	36.27	18.07	6500	4.55
6400	13.02	23.81	18.40	6.59	1.49	0.31	37.27	17.80	7000	4.79
6600	12.65	23.63	18.23	6.43	1.52	0.32	36.34	17.64	7500	4.71
6800	12.08	23.80	16.49	6.27	1.61	0.31	35.42	16.93	8000	5.32
7000	11.46	24.06	14.86	6.07	1.73	0.30	37.18	15.19	8500	5.91
7200	10.83	24.04	13.21	5.91	1.81	0.31	36.90	14.77	9000	6.27
7500	9.80	24.01	11.28	5.79	1.96	0.32	34.77	13.81	9500	7.84
8000	7.96	23.58	9.17	5.66	2.16	0.33	32.29	12.76	10000	7.66

REV. X1  
GALI-24+  
070823

Page 6 of 11



IF/RF MICROWAVE COMPONENTS • ISO 9001 ISO 14001 AS 9100 CERTIFIED • RoHS compliant

P.O. Box 350166, Brooklyn, New York 11235-0003 (718) 934-4500 Fax (718) 332-4661



The Design Engineers Search Engine finds the model you need, Instantly • For detailed performance specs & shopping online see



## Typical Performance Data

### Definitions:

Input Return Loss = -S11 (dB)

Gain(Power Gain) = S21 (dB)

Reverse Isolation = -S12 (dB)

Output Return Loss = -S22 (dB)

TEST CONDITIONS: Icc = 80mA, Vd = 5.54V @Temperature = +85degC

FREQ	Gain	Isolation	Input Return Loss	Output Return Loss	Stability		IP3 Output	1dB Comp. Output	FREQ	Noise Figure
(MHz)	(dB)	(dB)	(dB)	(dB)	K	Delta	(dBm)	(dBm)	(MHz)	(dB)
50	25.27	29.19	21.34	19.43	1.08	0.63	33.82	19.25	50	4.46
100	25.19	29.34	22.03	18.68	1.09	0.61	33.63	19.34	100	4.57
200	25.04	28.96	22.85	17.40	1.08	0.63	33.72	19.15	200	4.58
400	24.60	28.96	21.39	15.50	1.09	0.59	33.69	19.10	400	4.76
600	23.98	28.81	20.71	13.72	1.10	0.55	33.79	18.96	600	4.71
800	23.27	28.46	20.24	12.25	1.10	0.53	34.46	19.04	800	4.83
1000	22.53	28.27	19.77	11.30	1.12	0.49	34.84	19.05	1000	4.78
1200	21.78	28.02	19.45	10.51	1.14	0.46	34.94	18.62	1200	4.80
1400	21.04	27.65	18.90	9.92	1.15	0.44	34.82	18.79	1400	4.87
1600	20.32	27.42	18.48	9.51	1.18	0.41	35.19	18.93	1600	4.89
1800	19.66	27.11	17.82	9.22	1.20	0.39	35.95	18.88	1800	4.77
2000	19.06	26.84	17.18	9.00	1.21	0.37	35.76	19.06	2000	4.74
2200	18.47	26.53	16.65	8.97	1.23	0.35	35.88	19.17	2200	4.81
2400	17.94	26.22	16.07	8.94	1.25	0.34	35.76	19.32	2400	4.85
2600	17.47	25.90	15.53	9.03	1.26	0.33	35.79	19.21	2600	4.87
2800	17.01	25.69	15.20	9.05	1.28	0.32	35.68	19.09	2800	4.87
3000	16.61	25.34	14.71	9.04	1.28	0.31	35.76	19.11	3000	4.91
3200	16.22	25.15	14.50	9.24	1.31	0.30	35.76	19.06	3200	4.86
3400	15.88	24.90	14.26	9.32	1.32	0.30	35.48	19.09	3400	5.03
3600	15.54	24.66	14.20	9.46	1.34	0.29	35.16	18.94	3600	5.09
3800	15.22	24.54	14.15	9.63	1.37	0.29	34.29	18.59	3800	5.20
4000	14.93	24.37	14.07	9.72	1.39	0.28	33.51	18.08	4000	5.14
4200	14.60	24.16	14.21	9.70	1.41	0.28	33.47	17.87	4200	5.34
4400	14.29	24.05	14.42	9.63	1.44	0.28	33.47	17.66	4400	5.24
4600	13.97	24.01	14.65	9.48	1.48	0.28	33.04	17.30	4600	5.42
4800	13.64	23.94	14.74	9.29	1.51	0.27	32.61	16.77	4800	5.42
5000	13.35	24.02	14.78	9.12	1.56	0.26	32.53	16.41	5000	5.60
5200	13.02	24.10	14.88	8.93	1.62	0.26	32.46	16.13	5200	5.58
5400	12.70	24.17	15.18	8.83	1.69	0.25	32.02	15.86	5400	5.73
5600	12.37	24.28	15.64	8.78	1.77	0.24	31.62	15.68	5600	5.82
5800	12.01	24.24	16.02	8.62	1.83	0.24	31.43	15.35	5800	5.87
6000	11.60	24.47	16.06	8.51	1.95	0.23	31.38	14.75	6000	5.98
6200	11.19	24.62	16.38	8.51	2.08	0.22	31.51	13.32	6500	6.05
6400	10.75	24.62	16.69	8.57	2.19	0.22	31.88	12.95	7000	6.41
6600	10.28	24.87	16.00	8.36	2.36	0.22	31.00	13.44	7500	6.58
6800	9.79	24.68	15.12	8.38	2.44	0.23	30.55	13.35	8000	7.20
7000	9.08	25.20	13.61	8.21	2.73	0.22	30.45	13.52	8500	7.88
7200	8.43	24.90	12.62	8.26	2.83	0.23	30.89	13.43	9000	8.35
7500	7.23	24.34	11.21	8.12	2.96	0.24	30.69	11.99	9500	9.02
8000	5.42	24.12	8.89	7.41	3.24	0.25	29.31	11.45	10000	9.14

REV. X1  
GALI-24+  
070823

Page 7 of 11



IF/RF MICROWAVE COMPONENTS • ISO 9001 ISO 14001 AS 9100 CERTIFIED • RoHS compliant

P.O. Box 350166, Brooklyn, New York 11235-0003 (718) 934-4500 Fax (718) 332-4661



The Design Engineers Search Engine finds the model you need, Instantly • For detailed performance specs & shopping online see



## Typical Performance Data

### Definitions:

Input Return Loss = -S11 (dB)

Gain(Power Gain) = S21 (dB)

Reverse Isolation = -S12 (dB)

Output Return Loss = -S22 (dB)

TEST CONDITIONS: Icc = 60mA, Vd = 5.47V @Temperature = +85degC

FREQ	Gain	Isolation	Input Return Loss	Output Return Loss	Stability		IP3 Output	1dB Comp. Output	FREQ	Noise Figure
(MHz)	(dB)	(dB)	(dB)	(dB)	K	Delta	(dBm)	(dBm)	(MHz)	(dB)
50	24.62	27.96	17.32	29.42	1.06	0.68	28.33	15.00	50	4.37
100	24.55	28.05	17.54	25.93	1.06	0.66	28.13	15.10	100	4.44
200	24.43	28.50	18.14	22.01	1.09	0.62	28.16	14.93	200	4.56
400	24.03	28.30	17.40	17.56	1.08	0.60	28.13	14.99	400	4.73
600	23.44	28.01	17.17	14.95	1.08	0.57	28.31	14.90	600	4.68
800	22.77	27.85	17.07	13.05	1.08	0.53	28.99	15.00	800	4.80
1000	22.09	27.56	17.01	11.89	1.09	0.50	29.36	15.13	1000	4.73
1200	21.39	27.36	16.96	10.95	1.11	0.46	29.50	14.56	1200	4.75
1400	20.67	27.12	16.65	10.27	1.12	0.43	29.59	14.83	1400	4.81
1600	20.02	26.80	16.46	9.78	1.14	0.41	29.90	14.90	1600	4.82
1800	19.36	26.62	15.99	9.44	1.16	0.38	30.55	15.06	1800	4.69
2000	18.79	26.33	15.56	9.22	1.18	0.37	30.65	15.25	2000	4.66
2200	18.21	26.11	15.07	9.16	1.20	0.35	31.04	15.34	2200	4.74
2400	17.67	25.85	14.61	9.11	1.22	0.33	31.43	15.69	2400	4.74
2600	17.22	25.58	14.19	9.17	1.23	0.32	31.58	15.61	2600	4.75
2800	16.77	25.40	13.90	9.21	1.26	0.30	31.55	15.45	2800	4.74
3000	16.36	25.09	13.54	9.22	1.26	0.30	31.93	15.50	3000	4.76
3200	15.98	24.95	13.37	9.44	1.30	0.29	32.15	15.58	3200	4.71
3400	15.64	24.73	13.20	9.56	1.31	0.28	32.12	15.85	3400	4.92
3600	15.30	24.54	13.16	9.73	1.34	0.28	31.65	16.01	3600	4.93
3800	14.96	24.48	13.15	9.96	1.38	0.27	31.06	15.78	3800	5.08
4000	14.67	24.33	13.12	10.09	1.41	0.27	30.61	15.40	4000	5.02
4200	14.34	24.08	13.27	10.15	1.42	0.27	30.61	15.44	4200	5.17
4400	14.03	24.09	13.50	10.14	1.48	0.26	30.48	15.28	4400	5.08
4600	13.70	24.08	13.72	10.03	1.53	0.26	30.00	14.94	4600	5.27
4800	13.36	24.05	13.86	9.90	1.57	0.25	29.67	14.47	4800	5.27
5000	13.04	24.13	13.92	9.77	1.64	0.24	29.49	14.33	5000	5.45
5200	12.69	24.17	14.07	9.62	1.70	0.24	29.44	14.14	5200	5.43
5400	12.36	24.32	14.37	9.56	1.79	0.23	29.34	13.80	5400	5.55
5600	12.02	24.40	14.81	9.53	1.88	0.22	28.98	13.63	5600	5.65
5800	11.66	24.43	15.23	9.42	1.97	0.22	28.63	13.51	5800	5.69
6000	11.23	24.66	15.30	9.32	2.11	0.21	28.39	13.18	6000	5.79
6200	10.84	24.88	15.68	9.36	2.26	0.20	28.46	11.87	6500	5.85
6400	10.37	24.88	15.99	9.44	2.40	0.20	28.35	11.51	7000	6.21
6600	9.90	25.19	15.47	9.26	2.60	0.20	28.35	11.93	7500	6.31
6800	9.40	24.94	14.73	9.28	2.68	0.21	27.89	11.99	8000	6.95
7000	8.70	25.42	13.32	9.09	2.98	0.20	28.05	12.31	8500	7.62
7200	8.06	25.18	12.40	9.16	3.11	0.21	27.70	12.16	9000	8.10
7500	6.89	24.56	11.07	8.96	3.22	0.22	28.18	10.73	9500	8.79
8000	5.09	24.28	8.81	8.12	3.50	0.23	27.31	10.43	10000	8.91

REV. X1  
GALI-24+  
070823

Page 8 of 11



IF/RF MICROWAVE COMPONENTS • ISO 9001 ISO 14001 AS 9100 CERTIFIED • RoHS compliant

P.O. Box 350166, Brooklyn, New York 11235-0003 (718) 934-4500 Fax (718) 332-4661



The Design Engineers Search Engine finds the model you need, Instantly • For detailed performance specs & shopping online see



## Typical Performance Data

### Definitions:

Input Return Loss = -S11 (dB)

Gain(Power Gain) = S21 (dB)

Reverse Isolation = -S12 (dB)

Output Return Loss = -S22 (dB)

TEST CONDITIONS: Icc = 100mA, Vd = 5.56V @Temperature = +85degC

FREQ	Gain	Isolation	Input Return Loss	Output Return Loss	Stability		IP3 Output	1dB Comp. Output	FREQ	Noise Figure
					K	Delta				
(MHz)	(dB)	(dB)	(dB)	(dB)	K	Delta	(dBm)	(dBm)	(MHz)	(dB)
50	25.54	29.58	25.38	16.87	1.08	0.62	37.67	21.85	50	4.43
100	25.50	29.41	25.77	16.32	1.07	0.63	37.59	21.91	100	4.59
200	25.35	29.33	27.16	15.52	1.08	0.62	37.76	21.70	200	4.60
400	24.89	29.44	24.27	14.33	1.09	0.58	37.38	21.53	400	4.71
600	24.25	29.12	23.07	12.94	1.10	0.56	37.16	21.77	600	4.71
800	23.52	28.90	22.14	11.75	1.11	0.52	37.58	21.61	800	4.88
1000	22.75	28.61	21.22	10.95	1.13	0.49	37.79	21.49	1000	4.82
1200	21.96	28.31	20.60	10.29	1.15	0.46	37.63	21.59	1200	4.84
1400	21.22	27.98	19.90	9.75	1.17	0.43	37.30	21.49	1400	4.79
1600	20.49	27.64	19.26	9.37	1.19	0.41	37.71	21.49	1600	4.92
1800	19.80	27.38	18.67	9.11	1.21	0.39	38.26	21.53	1800	4.99
2000	19.17	26.99	17.97	8.93	1.22	0.37	38.03	21.26	2000	4.80
2200	18.57	26.77	17.43	8.91	1.26	0.35	37.73	21.12	2200	4.89
2400	18.04	26.40	16.97	8.93	1.27	0.34	37.43	21.10	2400	4.98
2600	17.56	26.08	16.27	8.93	1.28	0.33	37.13	21.17	2600	4.97
2800	17.05	25.88	16.21	9.09	1.32	0.32	37.29	21.06	2800	4.92
3000	16.67	25.47	15.59	9.05	1.30	0.32	37.35	21.16	3000	4.93
3200	16.28	25.28	15.34	9.18	1.33	0.31	37.32	21.26	3200	5.01
3400	15.92	25.04	15.05	9.34	1.35	0.30	37.16	21.26	3400	5.11
3600	15.58	24.82	14.82	9.45	1.36	0.29	36.60	21.14	3600	5.21
3800	15.25	24.58	14.81	9.58	1.38	0.29	35.47	21.03	3800	5.14
4000	14.98	24.42	14.71	9.67	1.39	0.29	34.65	20.88	4000	5.22
4200	14.67	24.31	15.02	9.67	1.43	0.28	35.11	20.70	4200	5.26
4400	14.36	24.24	15.17	9.62	1.46	0.28	34.83	20.45	4400	5.31
4600	14.11	24.11	15.20	9.46	1.48	0.28	34.50	20.22	4600	5.48
4800	13.80	24.07	15.30	9.21	1.51	0.27	34.24	19.78	4800	5.61
5000	13.51	24.08	15.72	9.04	1.56	0.27	33.96	19.23	5000	5.64
5200	13.20	24.16	15.59	8.86	1.61	0.26	33.96	18.81	5200	5.64
5400	12.87	24.09	15.73	8.62	1.64	0.26	33.36	18.52	5400	5.75
5600	12.55	24.16	16.26	8.56	1.71	0.25	33.19	18.14	5600	5.80
5800	12.15	24.25	16.41	8.38	1.79	0.24	33.07	17.67	5800	6.04
6000	11.75	24.33	16.65	8.35	1.89	0.24	32.75	17.23	6000	5.99
6200	11.33	24.35	16.85	8.28	1.98	0.23	32.89	16.89	6500	6.04
6400	10.83	24.52	16.39	8.20	2.12	0.23	32.80	16.66	7000	6.36
6600	10.30	24.38	16.03	8.20	2.22	0.23	32.24	16.42	7500	6.34
6800	9.70	24.56	15.02	8.14	2.40	0.23	32.31	15.50	8000	6.87
7000	9.05	24.71	13.75	7.98	2.58	0.23	33.07	14.41	8500	7.92
7200	8.37	24.59	12.65	7.91	2.71	0.23	33.50	14.00	9000	7.92
7500	7.33	24.67	11.10	7.61	2.96	0.24	32.55	13.06	9500	9.06
8000	5.44	24.13	8.98	7.08	3.19	0.26	30.07	11.61	10000	9.69

REV. X1  
GALI-24+  
070823

Page 9 of 11



IF/RF MICROWAVE COMPONENTS • ISO 9001 ISO 14001 AS 9100 CERTIFIED • RoHS compliant

P.O. Box 350166, Brooklyn, New York 11235-0003 (718) 934-4500 Fax (718) 332-4661



The Design Engineers Search Engine finds the model you need, Instantly • For detailed performance specs & shopping online see



## Typical Performance Curves

**GAIN vs. TEMPERATURE**

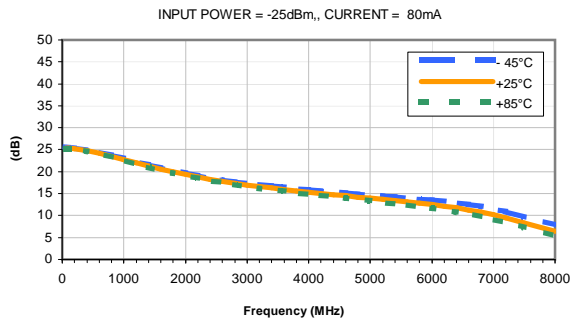

**GAIN vs. CURRENT**

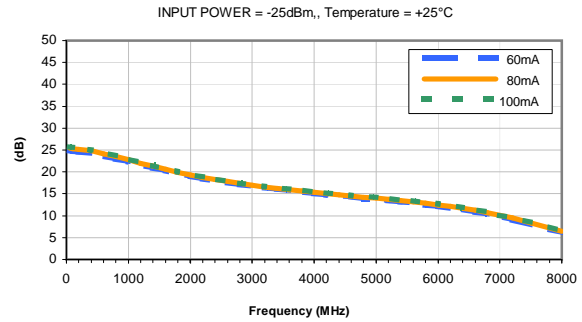

**ISOLATION vs. TEMPERATURE**

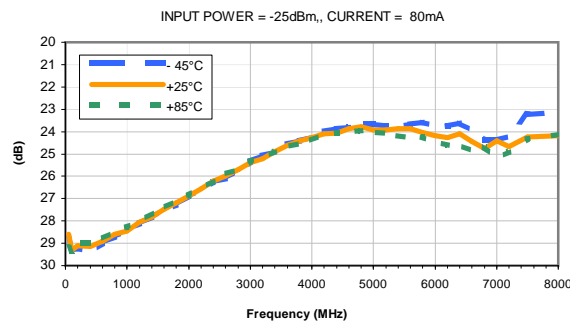

**ISOLATION vs. CURRENT**

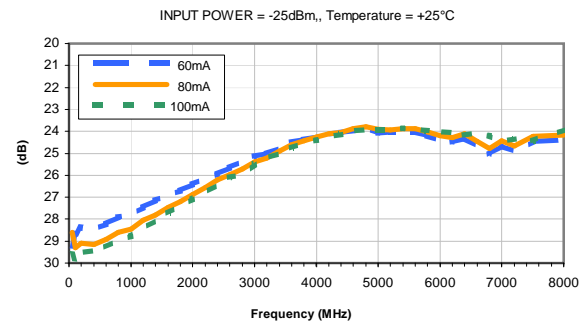

**INPUT RETURN LOSS vs. TEMPERATURE**

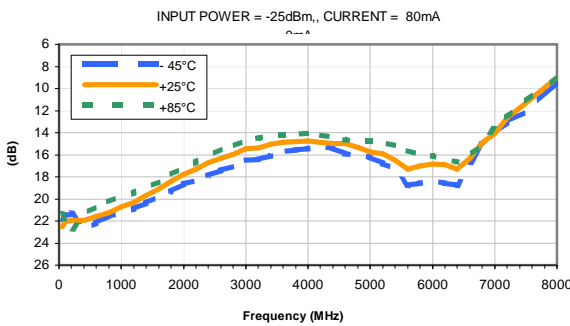

**INPUT RETURN LOSS vs. CURRENT**

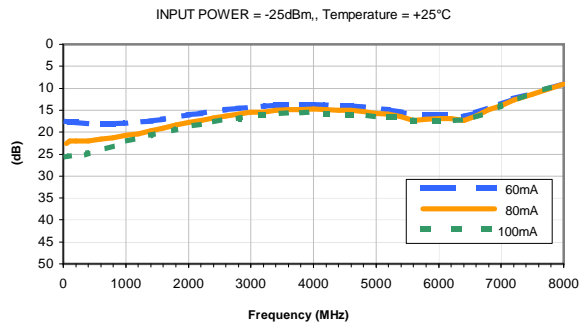

**OUTPUT RETURN LOSS vs. TEMPERATURE**

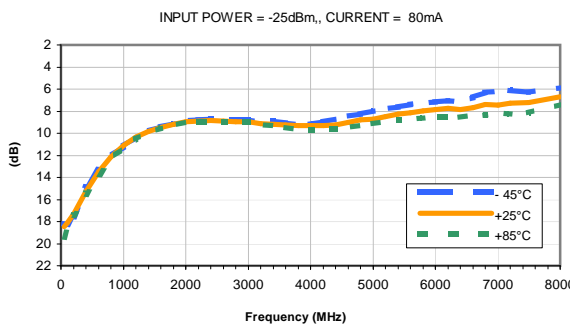

**OUTPUT RETURN LOSS vs. CURRENT**

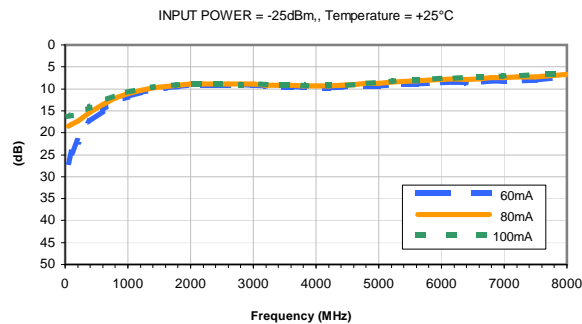

## Typical Performance Curves

**OUTPUT IP3 vs. TEMPERATURE**

INPUT POWER = -25dBm, CURRENT = 80mA

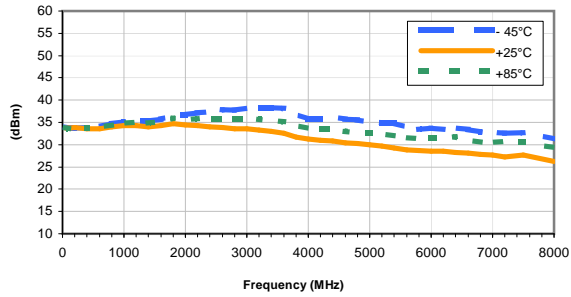

**OUTPUT IP3 vs. CURRENT**

INPUT POWER = -25dBm, Temperature = +25°C

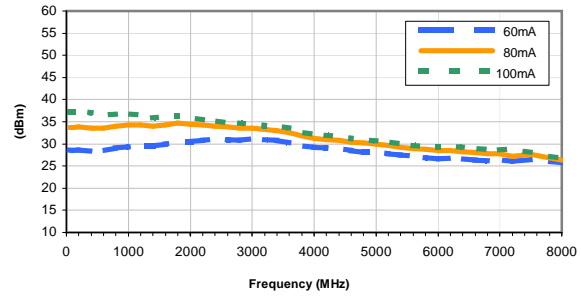

**OUTPUT POWER at 1dB Compression vs. TEMPERATURE**

CURRENT = 80mA

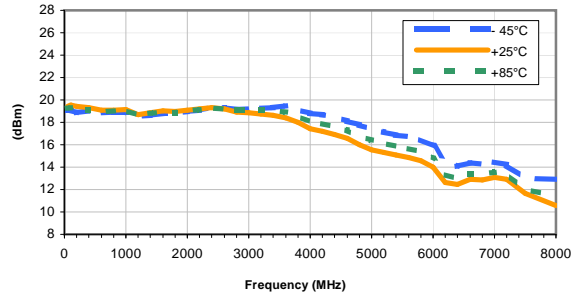

**OUTPUT POWER at 1dB Compression vs. CURRENT**

Temperature = +25°C

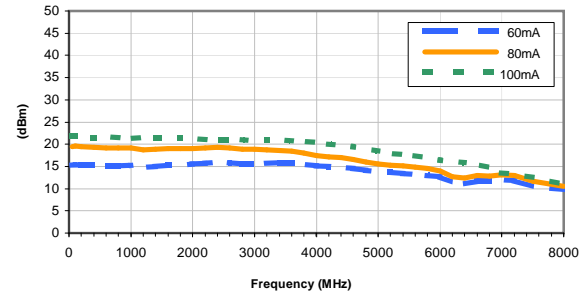

**Noise Figure vs. TEMPERATURE**

CURRENT = 80mA

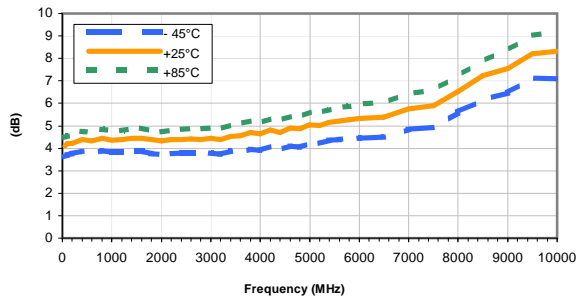

**Noise Figure vs. CURRENT**

Temperature = +25°C

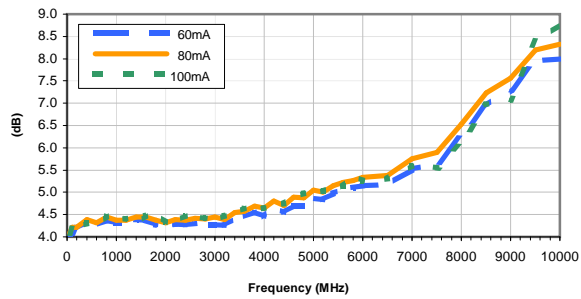



## Typical Performance Curves

**GAIN vs. TEMPERATURE**

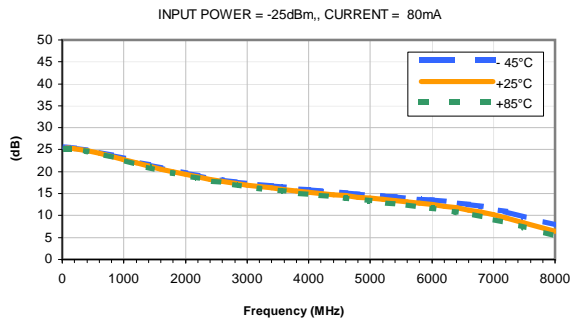

**GAIN vs. CURRENT**

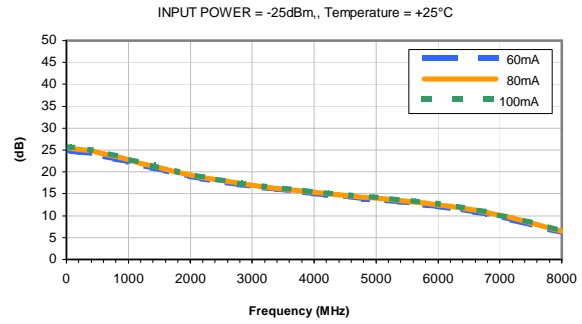

**ISOLATION vs. TEMPERATURE**

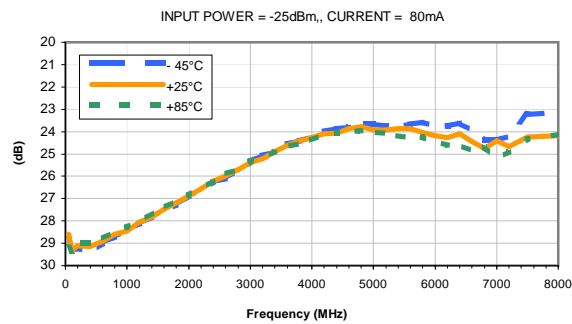

**ISOLATION vs. CURRENT**

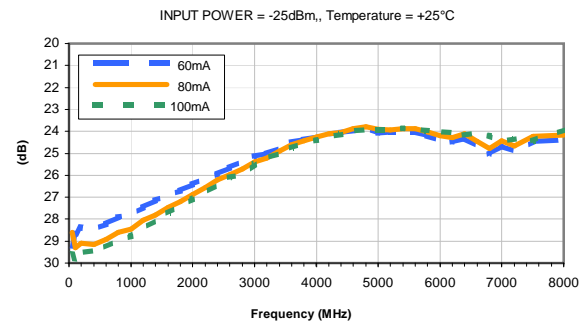

**INPUT RETURN LOSS vs. TEMPERATURE**

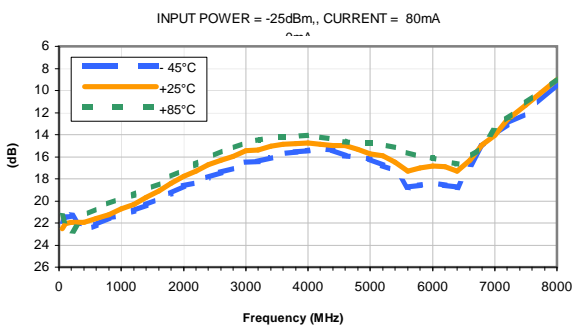

**INPUT RETURN LOSS vs. CURRENT**

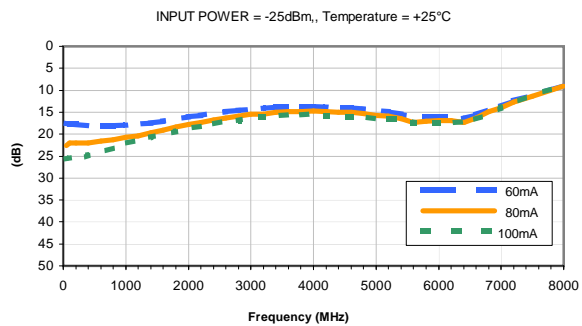

**OUTPUT RETURN LOSS vs. TEMPERATURE**

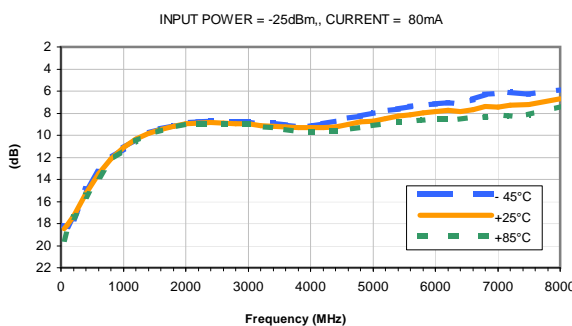

**OUTPUT RETURN LOSS vs. CURRENT**

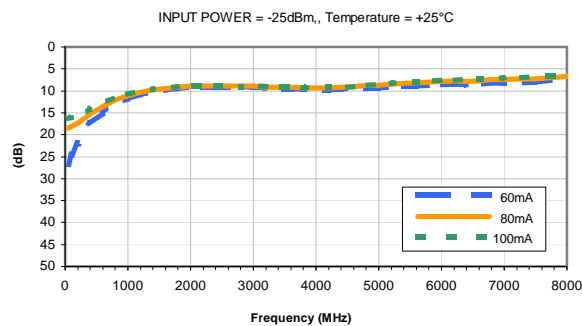

IF/RF MICROWAVE COMPONENTS • ISO 9001 ISO 14001 AS 9100 CERTIFIED • RoHS compliant  
 P.O. Box 350166, Brooklyn, New York 11235-0003 (718) 934-4500 Fax (718) 332-4661



The Design Engineers Search Engine finds the model you need, Instantly • For detailed performance specs & shopping online see





## Typical Performance Curves

**OUTPUT IP3 vs. TEMPERATURE**

INPUT POWER = -25dBm, CURRENT = 80mA

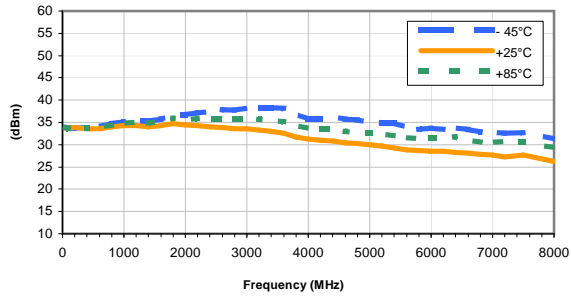

**OUTPUT IP3 vs. CURRENT**

INPUT POWER = -25dBm, Temperature = +25°C

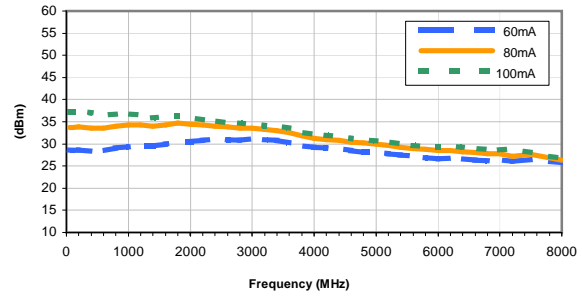

**OUTPUT POWER at 1dB Compression vs. TEMPERATURE**

CURRENT = 80mA

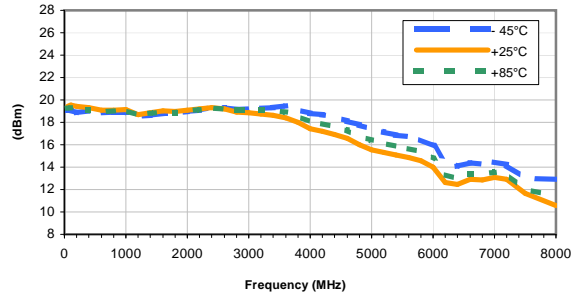

**OUTPUT POWER at 1dB Compression vs. CURRENT**

Temperature = +25°C

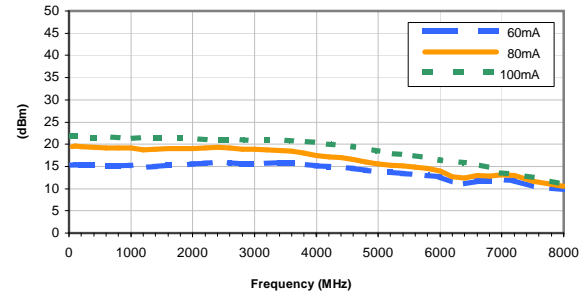

**Noise Figure vs. TEMPERATURE**

CURRENT = 80mA

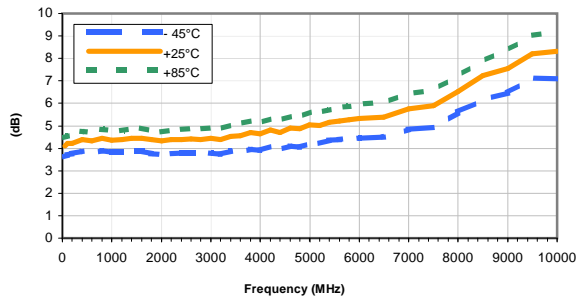

**Noise Figure vs. CURRENT**

Temperature = +25°C

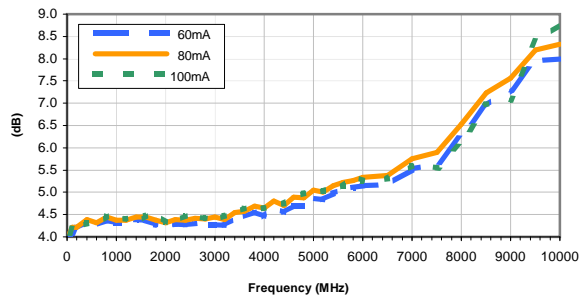

### Outline Dimensions



### PCB Land Pattern



Suggested Layout,  
Tolerance to be within  $\pm .002$

CASE #	A	B	C	D	E	F	G	H	J	K	L	M
DF782	.102 (2.59)	.090 (2.29)	.181 (4.60)	.173 (4.39)	.063 (1.60)	.167 (4.24)	.155 (3.94)	.059 (1.50)	.118 (3.00)	.015 (0.38)	.041 (1.04)	.016 (0.41)

CASE #	N	P	Q	WT. GRAM
DF782	.019 (0.48)	.065 (1.65)	.062 (1.57)	.2

Dimensions are in inches (mm). Tolerances: 2 Pl.  $\pm .01$ ; 3Pl.  $\pm .005$

#### Notes:

- Case material: Plastic.
- Termination finish:  
For RoHS Case Styles: Tin-Silver alloy plate over Nickel barrier or Matte-Tin.  
All models, (+) suffix. See model Data sheet.  
For RoHS-5 Case Styles: Tin-Lead plate. All models, no (+) suffix.



INTERNET <http://www.minicircuits.com>

P.O. Box 350166, Brooklyn, New York 11235-0003 (718) 934-4500 Fax (718) 332-4661

Distribution Centers NORTH AMERICA 800-654-7949 • 417-335-5935 • Fax 417-335-5945 • EUROPE 44-1252-832600 • Fax 44-1252-837010

Mini-Circuits ISO 9001 & ISO 14001 Certified

# Tape & Reel Packaging TR-F55

## DEVICE ORIENTATION IN T&R



Tape Width, mm	Device Cavity Pitch, mm	Reel Size, inches	Devices per Reel	
12	8	7	Small quantity standard (see note)	20
				50
				100
				200
				500
			Standard	1000

Note: Please consult individual model data sheet to determine device per reel availability.

Mini-Circuits carrier tape materials provide protection from ESD (Electro-Static Discharge) during handling and transportation. Tapes are static dissipative and comply with industry standards EIA-481/EIA-541.

Go to: [www.minicircuits.com/pages/pdfs/tape.pdf](http://www.minicircuits.com/pages/pdfs/tape.pdf)



INTERNET <http://www.minicircuits.com>

P.O. Box 350166, Brooklyn, New York 11235-0003 (718) 934-4500 Fax (718) 332-4661

Distribution Centers NORTH AMERICA 800-654-7949 • 417-335-5935 • Fax 417-335-5945 • EUROPE 44-1252-832600 • Fax 44-1252-837010

Mini-Circuits ISO 9001 & ISO 14001 Certified

THIRD ANGLE PROJECTION



REVISIONS

REV	ECN No.	DESCRIPTION	DATE	DR	AUTH
A	M76190	CHANGED DISCRIPTION	04/01	GF	CT
B	M82575	UPDATED DRAWING	08/05/02	AV	LC
C	M102713	ADDED NOTE 2 & "...WITH SMOBC"	01/17/06	MMG	IL
D	M108434	UPDATED DRAWING PER TB-409+	11/14/06	PW	IG

SUGGESTED MOUNTING CONFIGURATION  
FOR DF782 CASE STYLE, "mz" PIN CONNECTION



- NOTES:** 1. TRACE WIDTH IS SHOWN FOR ROGERS R04350B WITH DIELECTRIC THICKNESS .030" ± .002"; COPPER: 1/2 OZ. EACH SIDE. FOR OTHER MATERIALS TRACE WIDTH MAY NEED TO BE MODIFIED.  
2. BOTTOM SIDE OF THE PCB IS CONTINUOUS GROUND PLANE.



DENOTES PCB COPPER LAYOUT WITH SMOBC (SOLDER MASK OVER BARE COPPER)



DENOTES COPPER LAND PATTERN FREE OF SOLDER MASK

UNLESS OTHERWISE SPECIFIED	INITIALS	DATE
DRAWN	AV	01/15/01
CHECKED	YB	01/23/01
APPROVED	DB	01/23/01

**Mini-Circuits®**  
THIS DOCUMENT AND ITS CONTENTS ARE THE PROPERTY OF MINI-CIRCUITS. EXCEPT FOR USE EXPRESSLY GRANTED, IN WRITING, TO ITS VENDORS, VENDEE AND THE UNITED STATES GOVERNMENT, MINI-CIRCUITS RESERVES ALL PROPRIETARY DESIGN, USE, MANUFACTURING AND REPRODUCTION RIGHTS THERETO. THESE CONTENTS SHALL NOT BE USED, DUPLICATED OR DISCLOSED TO ANY OUTSIDE PARTY, IN WHOLE OR IN PART, WITHOUT WRITTEN PERMISSION OF MINI-CIRCUITS.

**Mini-Circuits®** 13 Neptune Avenue  
Brooklyn NY 11235

PL, mz, DF782, GALI, TB-409-XXX+

SIZE	CODE IDENT	DRAWING NO:	REV:
A	15542	98-PL-019	D
FILE:	98PL019	SCALE:	10:1
		SHEET:	1 OF 1

# Evaluation Board and Circuit

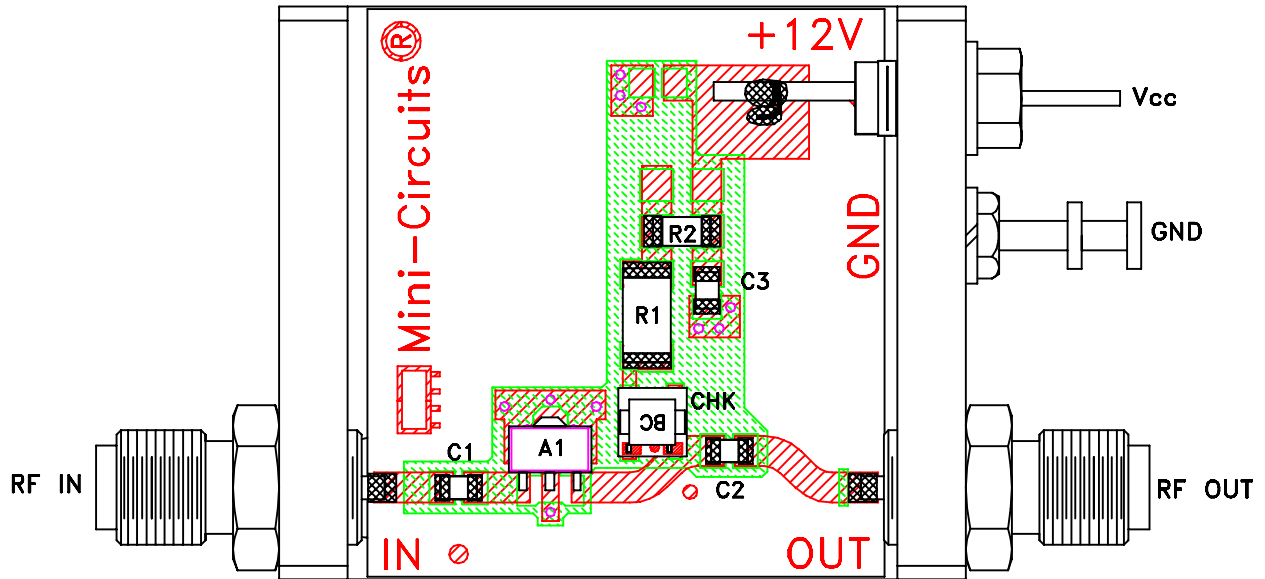

TB-409-24+

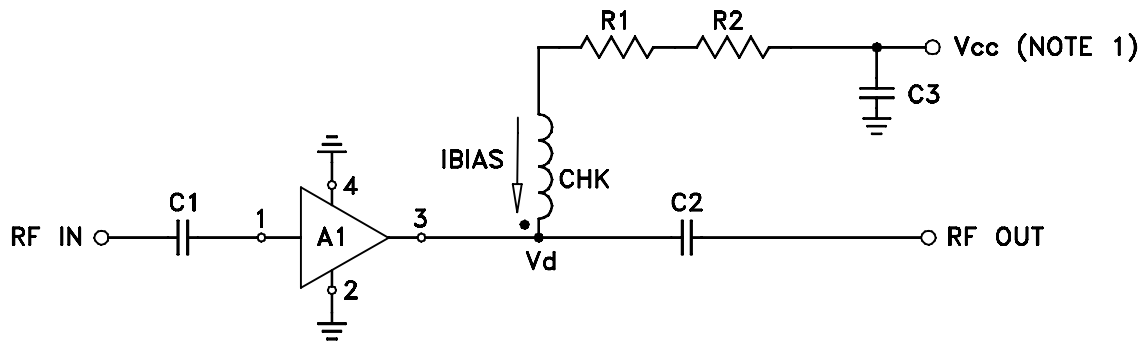

COMPONENT	VALUE
A1	Gali-24(+)
C1 (NOTE 4)	2400 pF
C2 (NOTE 4)	2400 pF
C3 (bypass)	0.1 uF
R1	68.1 Ohms, 0.75W
R2	10 Ohms, 0.25W
CHK	Mini-Circuits TCCH-80+

Schematic Diagram

**NOTE:**

1. Vcc voltage: +12±0.2V.
2. SMA Female connectors.
3. PCB material: Rogers RO4350 or equivalent, dielectric constant=3.5, dielectric thickness=.030 inch.
4. Capacitors, C1 & C2 should be free of resonance up to the highest frequency specified.

Mini-Circuits®

All Mini-Circuits products are manufactured under exacting quality assurance and control standards, and are capable of meeting published specifications after being subjected to any or all of the following physical and environmental test.

Specification	Test/Inspection Condition	Reference/Spec
Operating Temperature	-45° to 85°C or -40° to 85°C Ambient Environment	Individual Model Data Sheet
Storage Temperature	-65° to 150° C Ambient Environment	Individual Model Data Sheet
Thermal Shock	-55° to 100°C, 100 cycles	MIL-STD-202, Method 107, Condition A-3, except +100°C
Mechanical Shock	1.5Kg, 0.5 ms, 5 shock pulses, Y1 direction only	MIL-STD-883, Method 2002, Condition B, except Y1 direction only
Vibration (Variable Frequency)	50g peak	MIL-STD-883, Method 2007, Condition B
Autoclave	15 psig, 100% RH, 121°C, 96 hours	JESD22-A102, Condition C
HAST	130°C, 85% RH, 96 hours	JESD22-A110
Solderability	10X Magnification	J-STD-002, Para 4.2.5, Test S, 95% Coverage
Solder Reflow Heat	Sn-Pb Eutetic Process: 240°C peak Pb-Free Process: 260°C peak	J-STD-020, Table 4-1, 4-2 and 5-2; Figure 5-1
Moisture Sensitivity: Level 1	Bake at 125°C for 24 hours Soak at 85°C/85% RH for 168 hours, Reflow 3 cycles at 260°C peak	J-STD-020
Marking Resistance to Solvents	Isopropyl alcohol + mineral spirits at 25°C; terpene defluxer at 25°C; distilled water + proylene glycol monomethyl ether +	MIL-STD-202, Method 215



All Mini-Circuits products are manufactured under exacting quality assurance and control standards, and are capable of meeting published specifications after being subjected to any or all of the following physical and environmental test.

<b>Specification</b>	<b>Test/Inspection Condition</b>	<b>Reference/Spec</b>
	monoethanolamine at 63°C to 70°C	