



MILLIMETER WAVE / USB / ETHERNET

Frequency Extender

FX-30GHP-RC

Mini-Circuits

50Ω 10 MHz to 30 GHz -40 dBm to +28 dBm

THE BIG DEAL

- Multiply 15 GHz signal source to 30 GHz
- Buffer input signals for +28 dBm output level
- Integrates seamlessly with SSG-15G-RC signal generator
- USB and Ethernet control

APPLICATIONS

- Wideband signal generator / LO source
- Characterise components at high power
- 5G FR2 bands n257, n258 & n261
- K & Ku band radar
- Microwave & millimeter wave radio testing



Generic photo used for illustration purposes only.

Model No.	FX-30GHP-RC
Case Style	SL3225
RF Connectors	SMA / 2.92mm

DOWNLOAD

SOFTWARE PACKAGE

RoHS Compliant

See our website for RoHS Compliance methodologies and qualifications

PRODUCT OVERVIEW

Mini-Circuits FX-30GHP-RC is a wideband frequency extender and buffer module, designed to multiply an existing 15 GHz signal source for operation up to 30 GHz.

Stand-Alone Frequency Extender & Buffer Amplifier

As a stand-alone unit, the FX-30GHP-RC will switch automatically between signal paths according to the output frequency requested by the user. The low-band path covers 10 MHz to 15 GHz and allows a signal source to be passed straight from input to output via a 20 dB buffer amplifier, for output levels up to +28 dBm. The high-band path allows the same input frequency range to be routed through a doubler with gain control and harmonic filtering, extending the original 15 GHz signal source up to 30 GHz with output power up to +28 dBm.

The system is controlled via Ethernet or USB using Mini-Circuits' powerful GUI for Windows or comprehensive API. SSH, HTTP & Telnet protocols are supported via Ethernet, with programming support for most common languages.

Cost-Effective 10 MHz to 30 GHz Signal Generator

FX-30GHP-RC integrates seamlessly with Mini-Circuits' SSG-15G-RC to create a single, cost effective, high power millimeter wave signal generator, offering CW and pulsed outputs from 10 MHz to 30 GHz. All required accessories are included and can be set up in moments, just connect the RF and serial control cables between the signal source and frequency extender modules, plug in the power supply and turn on.

Refer to <https://www.minicircuits.com/WebStore/dashboard.html?model=SSG-30GHP-RC> for the full specifications and features when configured as a 10 MHz to 30 GHz signal generator

KEY FEATURES

Feature	Advantages
Works with SSG-15G-RC	The FX-30GHP-RC is designed to interface seamlessly with the SSG-15G-RC, effectively providing the user a single 10 MHz to 30 GHz generator using the standard SSG software with all available functions.
USB & Ethernet control	USB HID and Ethernet (HTTP / Telnet / SSH) interfaces provide easy compatibility with a wide range of software setups and programming environments.
Full software support	User friendly Windows GUI (graphical user interface) allows manual control straight out of the box, while the comprehensive API (application programming interface) with examples and instructions allows easy automation in most programming environments

Trademarks:

All trademarks cited within this document are the property of their respective owners. Neither Mini-Circuits nor the Mini-Circuits products are affiliated with or endorsed or sponsored by the owners of the above referenced trademarks. Mini-Circuits and the Mini-Circuits logo are registered trademarks of Scientific Components Corporation.

Mini-Circuits

www.minicircuits.com P.O. Box 350166, Brooklyn, NY 11235-0003 (718) 934-4500 sales@minicircuits.com

Rev. A
ECO-015229
EDR-11904/1
FX-30GHP-RC
MCIL
220930
PAGE 1 OF 10



ELECTRICAL SPECIFICATIONS AT +25°C

GENERAL SPECIFICATIONS

Parameter	Condition (GHz)	Min.	Typ.	Max.	Unit
Output Frequency	-	0.01	-	30	GHz
Input Frequency	-	0.01	-	15	GHz
Band Switching Time ^{1, 2}	-	-	300	450	µs
Return Loss In	0.01-15	-	12.0	-	dB
Return Loss Out	0.01-25	-	15.0	-	dB
	25-30	-	12.0	-	

1. Time from start of transition between any two bands to settled RF output level, excluding communication delays (see Communication parameters table)

2. The FX-30GHP-RC has 5 frequency bands: 0.01-15 GHz, 15-17.8 GHz, 17.8-21.2 GHz, 21.2-25.2 GHz and 25.2-30 GHz.

LOW BAND (BUFFER AMPLIFIER) SPECIFICATIONS

Operates as a buffer amplifier, input frequency is the same as output frequency.

The FX-30GHP-RC will calculate the required power level for a requested output power and frequency when queried.

Parameter	Condition (GHz)	Min.	Typ.	Max.	Unit
Output Frequency	-	0.01	-	15	GHz
Input Frequency	-	0.01	-	15	GHz
Input Power	0.01 - 15	-	-	13	dBm
Output Power Max ^{3, 4}	0.01 - 12	+26	+28	-	dBm
	12 - 15	+25	+27	-	
Gain @ small signal	0.01	-	31	-	dB
	5	-	25	-	
	10	-	20.5	-	
	15	-	16.5	-	
Power Out @ 1dB Compression	0.01	-	21.5	-	dB
	1	-	25.0	-	
	5	-	24.5	-	
	10	-	25.0	-	
	15	-	23.0	-	
Output power Accuracy ⁵	0.01 - 15	-	±0.7	-	dB
Harmonics	0.01 - 15	-	-40	-	dBc
Non-Harmonic Spurious	-	-	-70	-	dBc

3. The frequency extender is calibrated within typical power range, however performance is guaranteed only within power max/min limits.

4. Saturation power level

5. Power accuracy not including any deviation in power in from required level.

**HIGH BAND (FREQUENCY DOUBLER MODE) SPECIFICATIONS**

Operates as a frequency doubler with 4 frequency bands and power control, input frequency is half the output frequency. Specifications are for input power of +10 dBm.

Parameter	Condition (GHz)		Min.	Typ.	Max.	Unit
Output Frequency	-		15	-	30	GHz
Input Frequency	-		7.5	-	15	GHz
Band Switching Time ^{1,2}	-		-	300	450	µs
Input Power	7.5 - 15		8.5	10	13	dBm
Output Power Resolution	15 - 30		-	0.5	-	dB
Output Power Max	15 - 27		+23	+25	-	dBm
	27 - 30		+20	+22	-	
Output Power Min	15 - 30		-	-40	-35	dBm
Output power Accuracy	15 - 27	PWR _{out} : -35 to +23 dBm	-	±1.0	-	dB
	27-30	PWR _{out} : -35 to +20 dBm	-	±1.0	-	
Harmonics	15 - 30	-35 to +10 dBm	-	-40	-	dBc
		+10 dBm to Max Power	-	-20	-	
Sub-Harmonics	15 - 30	-35 to 0 dBm	-	-10	-	dBc
		0 dBm to Max Power	-	-40	-	
Non-Harmonic Spurious	-		-	-70	-	dBc
Additive Phase Noise ⁶	15 - 30		-	6	-	dB

6. Tested with 50 Ohm source and tester.

DC SPECIFICATIONS

Parameter	Condition	Min	Typ	Max	Units
Supply Voltage	-	11.4	12	12.6	V _{DC}
Supply Current	-	-	650	800	mA
USB Current ⁷	-	-	0	-	

7. All power is drawn from power adaptor, however USB protocol monitors the voltage at USB port as part of the handshake protocol establishing communication.

COMMUNICATION PARAMETERS

Parameter		
Ethernet Communication	Protocol	TCP / IP, HTTP, Telnet, SSH, DHCP, UDP (limited)
	Max Data Rate	100 Mbps (100 Base-T Full Duplex)
USB Communication	Protocol	HID (Human Interface Device) - High-speed
	Min Communication Time ⁸	400 µs typ (full transmit/receive cycle)

8. USB min communication time is based on the polling interval of the USB HID protocol (125 µs polling interval, 1024 bytes per packet), medium CPU load and no other high speed USB devices using the USB bus.



ABSOLUTE MAXIMUM RATINGS ^{9,10}

Operating Temperature		0°C to 50°C
Storage Temperature		-20°C to 60°C
Reverse Power (DC) @ RF Out		16 V _{DC}
Reverse Power (RF) @ RF Out ¹¹	0.01 - 0.1 GHz	Derates linearly from +22 dBm at 100 MHz to +13 dBm at 10 MHz
	0.1 - 15 GHz	+22 dBm
	15 - 30 GHz	+21 dBm
Power In @ RF In	0.01 - 15 GHz	+14 dBm
	15 - 30 GHz	+17 dBm

9. Permanent damage may occur if any of these limits are exceeded.

10. Operating in the range between operating power limits and absolute maximum ratings for extended periods of time may result in reduced life and reliability.

11. Model can handle max output power into Open or Short.

PROCESS FLOW CHART

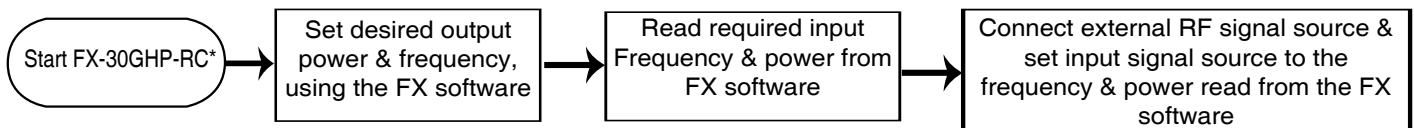

* Control is via either USB or Ethernet

BLOCK DIAGRAM

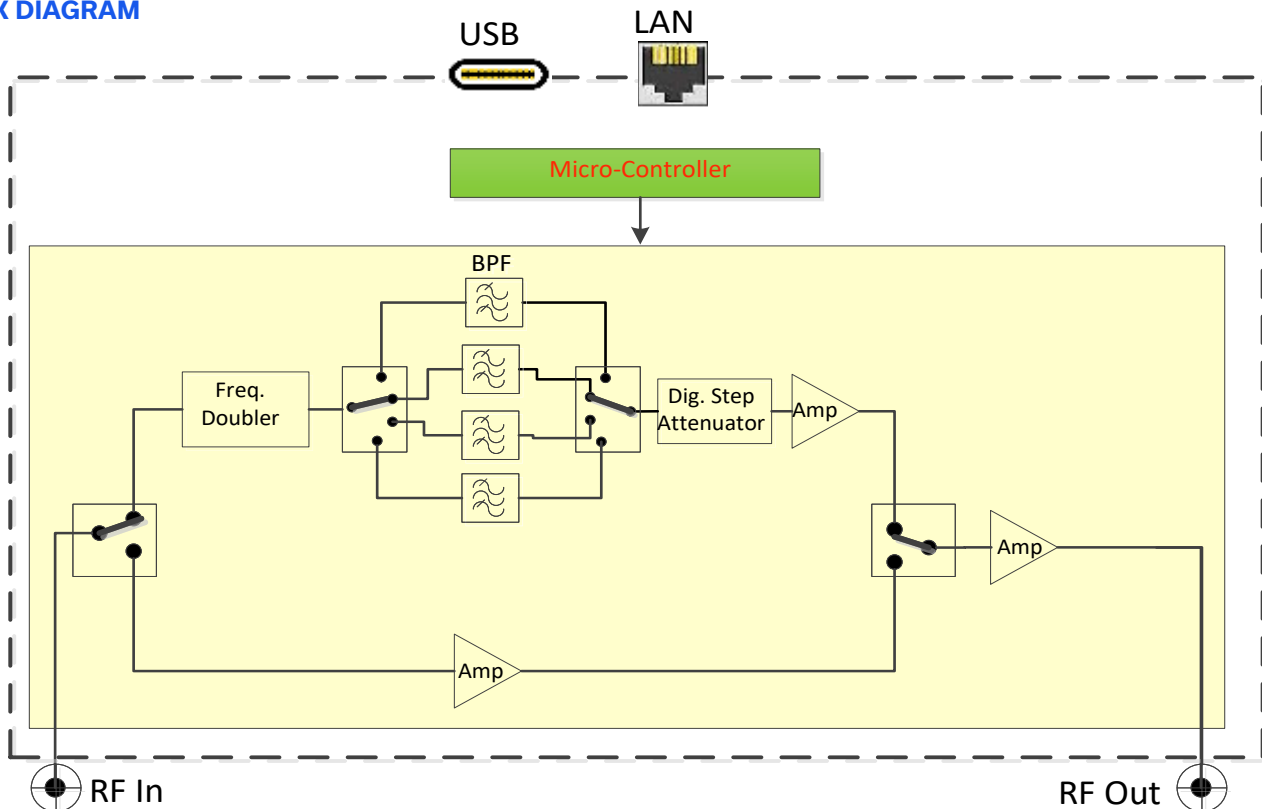



OUTLINE DRAWING (SL3225)

CONNECTIONS

Port Name	Connector Type	Description
J1	SMA-Female	RF Input
J2	2.92 mm Female	RF Output
DC	2.1 mm DC socket	DC Power In (12V) ¹²
USB	USB type C	USB Port
LAN	RJ45 socket	Network (Ethernet / LAN)
SF	Digital Snap Fit	Serial Control

12. No power On/Off switch. device will power on as soon as power is connected, starting at Max frequency band, minimum power.

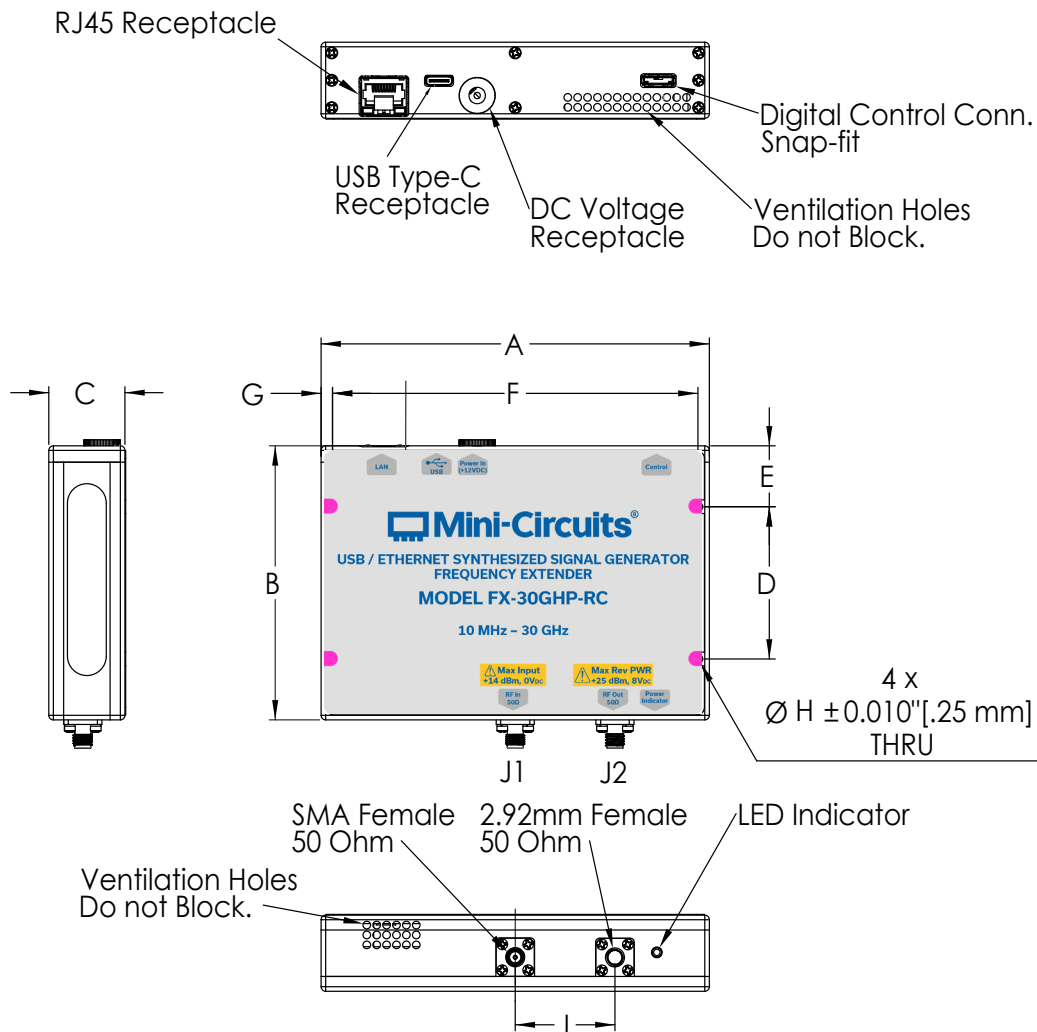

OUTLINE DIMENSIONS (INCH)

A	B	C	D	E	F	G	H	J	weight (grams)
5.10	3.60	1.00	2.00	0.80	4.80	0.15	0.125	1.31	600
129.50	91.40	25.40	50.80	20.32	121.92	3.81	3.180	33.27	



TYPICAL PERFORMANCE CURVES*

*at +25°C unless noted otherwise

Power Accuracy vs. Output Frequency

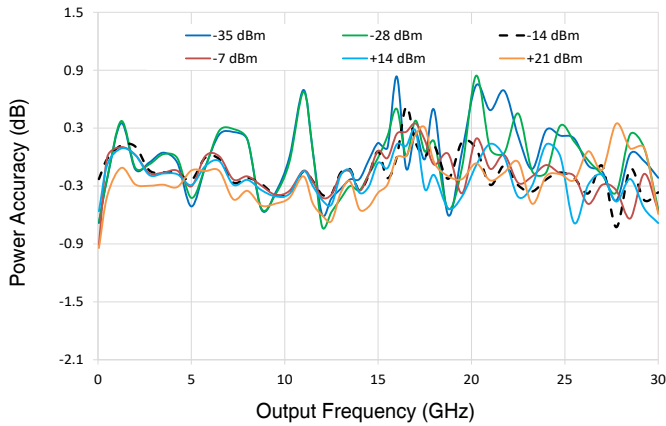

Power Accuracy vs. Output Power

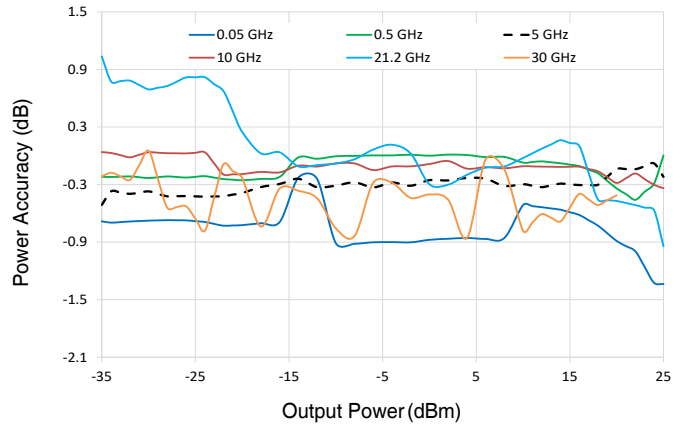

Harmonics vs. Output Frequency @ +20 dBm

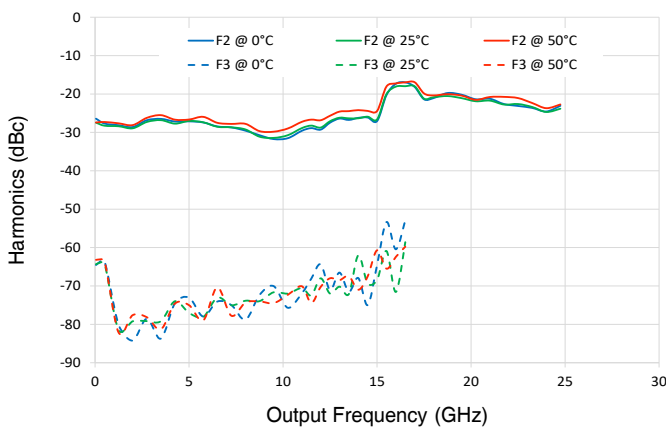

Sub-Harmonics vs. Output Frequency @ +20 dBm

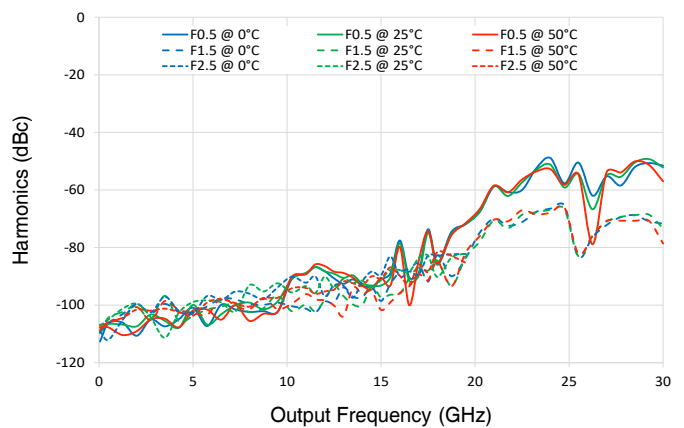



TYPICAL PERFORMANCE CURVES (CONTINUED)

Harmonics vs. Output Frequency @ +10 dBm

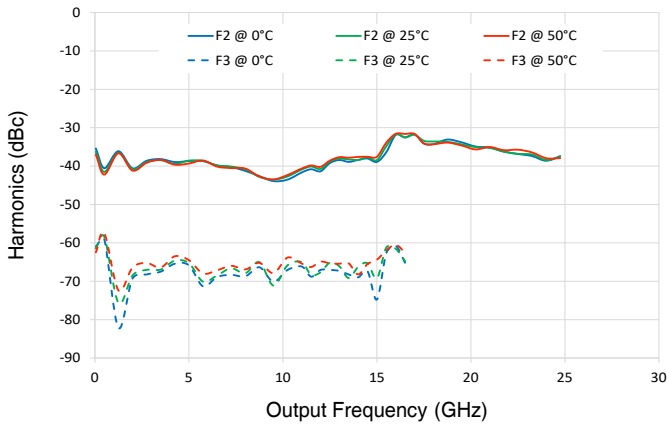

Sub-Harmonics vs. Output Frequency @ +10 dBm

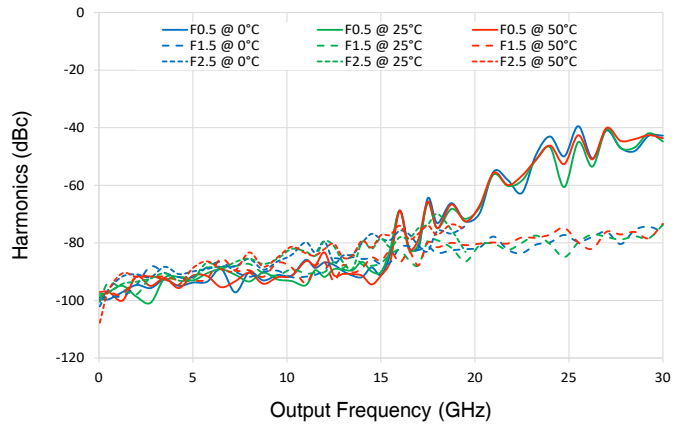

Harmonics vs. Output Frequency @ -20 dBm

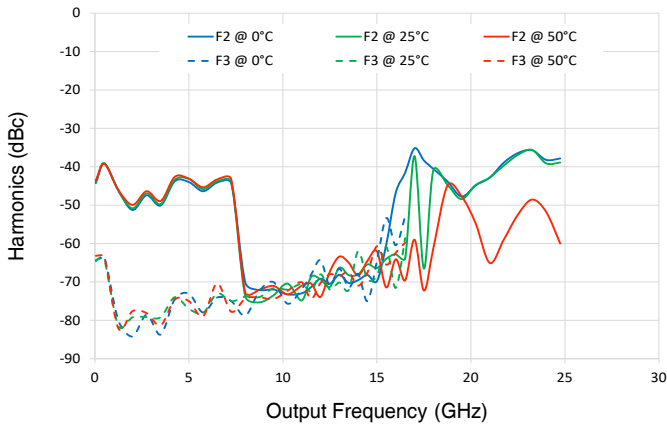

Sub-Harmonics vs. Output Frequency @ -20 dBm

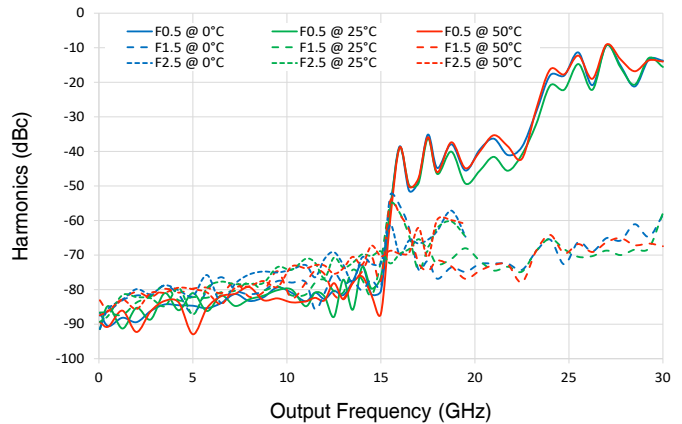

**SOFTWARE SPECIFICATIONS****SOFTWARE & DOCUMENTATION DOWNLOAD:**

- Mini-Circuits' full software and support package including user guide, Windows GUI, DLL files, programming manual and examples can be downloaded free of charge from: <https://www.minicircuits.com/softwaredownload/sg.html>
- Please contact testsolutions@minicircuits.com for support

MINIMUM SYSTEM REQUIREMENTS:

Parameter	Requirements	
Interface	USB HID or HTTP Get/Post or Telnet protocols or SSH protocols	
System Requirements	GUI	Windows 7 or later
	USB API DLL	Windows 7 or later and programming environment with ActiveX or .NET support
	USB Direct Programming	Linux, Windows 7 or later
	HTTP, Telnet or SSH	Any computer with a network port and Ethernet-TCP/IP (HTTP, Telnet or SSH protocols) support
Hardware	Intel i3 (or equivalent) or later	

APPLICATION PROGRAMMING INTERFACE (API)**ETHERNET SUPPORT:**

- Simple ASCII / SCPI command set for unit control
- Communication via HTTP or Telnet
- Supported by most common programming environments

USB SUPPORT (WINDOWS):

- ActiveX COM DLL file for creation of 32-bit programs
- .NET library DLL file for creation of 32 / 64-bit programs
- Supported by most common programming environments (refer to application note [AN-49-001](#) for summary of supported environments)
- Simple ASCII / SCPI command set to control the FX model

USB SUPPORT (LINUX):

- Direct USB programming using a series of USB interrupt codes



GRAPHICAL USER INTERFACE (GUI) FOR WINDOWS - KEY FEATURES

- Connect via USB or Ethernet
- Password protected access for safe remote usage over Ethernet

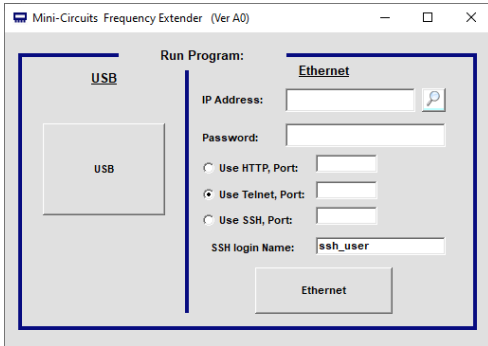



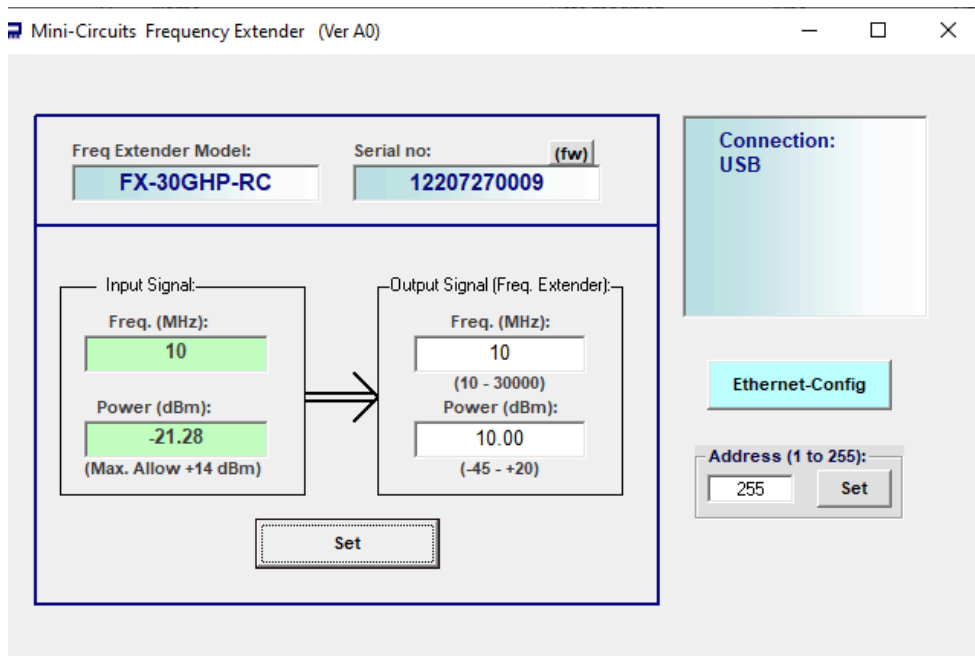





- Calculate power and Frequency input for a given RF Out.
- Set power out in 15 - 30 GHz range.
- Set mode automatically according to requested frequency.



**ORDERING INFORMATION**Please contact Mini-Circuits' Test Solutions department for price and availability: testsolutions@minicircuits.com

Model	Description
FX-30GHP-RC	USB/Ethernet Frequency Extender

Included Accessories	Part No.	Description
	AC/DC-12-3W	AC/DC Grounded Power adapter, 0°C to +40°C AC Input: 100-240 V, 50/60 Hz, $I_{Max} = 1.2A$ DC Output $12 \pm 0.6 V$, $I_{Max} = 3A$
See below images	CBL-3W-xx	AC Power Cord (Select one power cord from below with each Signal Generator)
	141-5SM+	5 in. (12.5 cm) RF cable for connecting the SSG to FX modules.
	CBL-0.5FT-MMD+	6 in. (15 cm) control cable for connecting the SSG to FX modules.
	USB-CBL-AC-3+	3.3 ft (1.0 m) USB Cable: USB type A(Male) to USB type C(Male)

AC Power Cords ¹³	Part No.	Description
	CBL-3W-US	Power Cord for United States
	CBL-3W-EU	Power Cord for Europe
	CBL-3W-UK	Power Cord for United Kingdom
	CBL-3W-AU	Power Cord for Australia and China
	CBL-3W-IL	Power Cord for Israel

13. Power cords for other countries are also available, if you need a power cord for a country not listed in the table please contact testsolutions@minicircuits.com

OPTIONAL ACCESSORIES

USB-CBL-AC-3+ (spare)	3.3 ft (1.0 m) USB Cable: USB type A(Male) to USB type C(Male)
CBL-RJ45-MM-5+	5 ft. network cable: RJ45 (Male) to RJ45 (Male) Cat 5E cable
CBL-0.5FT-MMD+ (spare)	3 in. (7.5 cm) control cable for connecting SSG-15G-RC to FX-30GHP-RC

CALIBRATION

CALFX-30GHP-RC	Calibration Service	Click Here
----------------	---------------------	----------------------------

NOTES:

- Performance and quality attributes and conditions not expressly stated in this specification document are intended to be excluded and do not form a part of this specification document.
- Electrical specifications and performance data contained in this specification document are based on Mini-Circuit's applicable established test performance criteria and measurement instructions.
- The parts covered by this specification document are subject to Mini-Circuits standard limited warranty and terms and conditions (collectively, "Standard Terms"); Purchasers of this part are entitled to the rights and benefits contained therein. For a full statement of the Standard Terms and the exclusive rights and remedies thereunder, please visit Mini-Circuits' website at <https://www.minicircuits.com/terms/viewterm.html>

Frequency Extender

FX-30GHP-RC

Typical Performance Data

Test Conditions: @ Temperature = 0°C.

Freq. (GHz)	Power deviation from nominal vs. Output Frequency (dB)									
	-35 dBm	-28 dBm	-21 dBm	-14 dBm	-7 dBm	0 dBm	+7 dBm	+14 dBm	+21 dBm	+25 dBm
0.05	0.15	0.15	0.11	0.62	0.59	0.61	0.57	0.49	0.06	-0.52
0.50	-0.05	-0.06	-0.07	0.15	0.12	0.13	0.12	0.09	-0.14	0.24
1.25	0.30	0.32	0.32	0.13	0.10	0.13	0.10	0.09	-0.04	-0.16
2.00	-0.23	-0.21	-0.32	0.22	0.14	0.18	0.19	0.13	-0.13	0.05
2.75	-0.27	-0.20	-0.22	0.21	0.17	0.18	0.20	0.17	0.07	0.31
3.50	0.05	0.08	0.06	0.20	0.19	0.18	0.16	0.17	0.08	0.00
4.25	0.13	0.04	0.02	0.07	0.04	0.00	0.11	0.09	-0.03	-0.13
5.00	-0.57	-0.22	0.02	0.07	0.01	-0.03	0.19	0.18	0.11	0.08
5.75	-0.10	-0.21	-0.42	-0.08	-0.09	-0.14	-0.11	-0.13	-0.17	-0.22
6.50	-0.06	-0.14	-0.19	0.02	0.02	-0.02	-0.01	-0.02	-0.09	-0.19
7.25	-0.21	-0.28	-0.22	-0.03	-0.01	-0.05	-0.05	-0.04	-0.14	-0.26
8.00	0.37	0.29	0.16	0.13	0.20	0.19	0.18	0.18	0.10	-0.10
8.75	-0.22	-0.27	0.08	0.02	-0.01	0.03	0.03	0.02	-0.05	-0.17
9.50	-0.35	-0.38	-0.31	-0.41	-0.41	-0.38	-0.45	-0.36	-0.38	-0.45
10.25	-0.09	-0.07	-0.20	-0.28	-0.28	-0.28	-0.30	-0.24	-0.25	-0.34
11.00	0.16	0.19	0.14	0.08	0.07	0.07	0.08	0.08	0.08	-0.01
11.50	-0.15	-0.19	0.07	0.16	0.19	0.18	0.19	0.15	0.04	-0.16
12.00	-0.30	-0.31	-0.03	0.16	0.13	0.13	0.09	0.10	0.02	-0.14
12.50	-0.09	-0.04	0.10	0.06	0.04	0.07	0.05	-0.02	-0.09	-0.35
13.00	-0.01	-0.09	0.40	0.44	0.42	0.44	0.46	0.44	0.31	-0.02
13.50	-0.16	-0.30	0.25	0.43	0.40	0.42	0.40	0.40	0.33	0.08
14.00	-0.04	-0.19	0.13	0.16	0.14	0.18	0.15	0.14	0.04	-0.20
14.50	0.10	-0.11	0.13	0.22	0.20	0.23	0.15	0.07	0.01	-0.28
15.00	0.19	0.04	0.22	0.21	0.24	0.13	0.18	0.15	0.04	0.06
15.50	-0.49	-0.34	-0.05	-0.25	-0.02	-0.54	-0.61	-0.33	0.27	-0.41
16.00	0.08	0.62	0.61	0.10	0.46	-0.06	0.18	0.22	0.56	-0.03
16.50	0.70	0.66	0.79	0.04	0.33	-0.21	0.09	0.12	0.56	-0.11
17.00	1.03	0.70	0.67	0.41	0.23	-0.05	0.20	0.05	0.72	-0.22
17.50	-0.24	0.42	0.89	-0.05	0.23	-0.43	0.25	0.14	0.83	-0.40
18.00	0.95	0.83	0.84	0.17	0.05	0.29	-0.05	-0.13	0.53	-0.37
18.75	-0.12	-0.06	0.12	-0.60	-0.22	-0.48	-0.30	-0.37	0.03	-0.48
19.50	-1.98	-0.55	-0.26	-0.63	-0.32	-0.09	-0.31	0.02	0.05	-0.59
20.25	0.41	0.76	0.86	0.10	-0.09	0.09	-0.24	0.07	0.13	-0.77
21.00	1.07	0.76	0.24	-0.27	-0.02	-0.53	-0.35	-0.42	0.12	-0.87
21.75	-0.03	0.02	-0.20	-0.82	-0.66	-0.53	-0.76	-0.75	-0.25	-1.02
22.50	-0.55	-0.47	-0.35	-0.74	-0.65	-0.55	-0.98	-0.74	-0.64	-1.00
23.25	-0.10	0.02	-0.20	-0.77	-0.61	-0.48	-0.41	-0.51	0.06	-0.77
24.00	-0.40	-0.33	-0.10	-0.84	-0.58	-0.45	-0.20	0.15	-0.09	-0.46
24.75	0.27	0.40	0.53	-0.27	-0.07	0.00	0.42	-0.05	0.44	-0.27
25.50	-0.57	-0.23	-0.55	-1.22	-0.85	-0.58	-0.41	-0.88	-0.77	-0.97
26.25	-0.27	-0.22	0.23	-0.47	-0.46	-0.29	-0.23	0.16	-0.11	-0.75
27.00	-0.77	-0.45	-0.84	-0.39	-0.88	-0.68	-0.74	-0.82	-0.45	-1.30
27.75	-0.40	-0.38	-0.46	-0.78	-0.59	-0.34	-0.45	-0.41	-0.06	--
28.50	-0.24	-0.34	-0.79	-0.36	-0.10	0.14	-0.68	-0.20	-0.07	--
29.25	-0.39	0.05	-0.83	-1.05	-0.81	-0.62	-0.56	-0.86	-0.55	--
30.00	-0.14	0.17	0.07	-0.25	0.01	0.41	-0.16	-0.21	-0.71	--

Frequency Extender

FX-30GHP-RC

Typical Performance Data

Test Conditions: @ Temperature = 0°C.

Power (dBm)	Power deviation from nominal vs. Output Power (dBm)									
	0.05 GHz	0.5 GHz	1 GHz	5 GHz	10 GHz	15 GHz	17.8 GHz	21.2 GHz	27 GHz	30 GHz
-35	0.15	-0.05	-0.20	-0.57	0.09	0.19	0.68	0.49	-0.77	-0.14
-34	0.12	-0.07	-0.23	-0.59	0.05	0.10	0.49	0.48	-0.69	-0.09
-33	0.14	-0.06	-0.22	-0.55	0.06	0.15	0.58	0.51	-0.58	0.02
-32	0.15	-0.05	-0.21	-0.51	0.08	0.20	0.66	0.55	-0.47	0.14
-31	0.15	-0.06	-0.21	-0.36	0.06	0.11	0.71	0.52	-0.55	0.11
-30	0.14	-0.08	-0.21	-0.20	0.03	0.02	0.75	0.49	-0.63	0.08
-29	0.15	-0.07	-0.21	-0.21	0.05	0.03	0.76	0.50	-0.54	0.13
-28	0.15	-0.06	-0.20	-0.22	0.08	0.04	0.78	0.50	-0.45	0.17
-27	0.17	-0.04	-0.18	-0.09	0.08	0.14	0.82	0.60	-0.48	0.26
-26	0.19	-0.02	-0.17	0.04	0.08	0.24	0.86	0.70	-0.50	0.34
-25	0.18	-0.03	-0.17	0.02	0.06	0.23	0.63	0.71	-0.43	0.08
-24	0.18	-0.03	-0.18	0.00	0.04	0.22	0.40	0.72	-0.36	-0.18
-23	0.16	-0.04	-0.19	0.01	-0.06	0.22	0.50	0.70	-0.50	-0.11
-22	0.14	-0.06	-0.20	0.01	-0.15	0.22	0.61	0.68	-0.64	-0.04
-21	0.11	-0.07	-0.22	0.02	-0.16	0.22	0.71	0.41	-0.84	0.07
-20	0.08	-0.08	-0.24	0.02	-0.16	0.21	0.80	0.13	-1.04	0.17
-18	0.07	-0.09	-0.24	0.28	-0.27	0.12	-0.17	-0.38	-0.89	-0.25
-16	0.05	-0.11	-0.25	-0.19	-0.32	0.12	0.15	-0.16	-0.55	0.00
-14	0.62	0.15	0.03	0.07	-0.05	0.21	0.05	-0.31	-0.39	-0.25
-12	0.61	0.15	0.03	0.00	-0.04	0.24	0.14	-0.27	-0.94	-0.08
-10	0.60	0.13	0.03	-0.01	-0.01	0.23	0.23	-0.22	-1.09	0.35
-8	0.60	0.12	0.02	0.00	-0.03	0.24	0.33	-0.16	-0.92	0.02
-6	0.58	0.11	0.01	0.01	-0.05	0.25	0.35	-0.06	-0.84	-0.01
-4	0.58	0.11	-0.01	0.01	-0.05	0.26	0.45	0.00	-0.65	0.10
-2	0.62	0.15	0.03	-0.05	-0.05	0.26	0.02	-0.06	-0.85	0.07
0	0.61	0.13	0.04	-0.03	-0.05	0.13	-0.35	0.00	-0.68	0.41
+2	0.62	0.14	0.04	0.00	-0.05	0.14	-0.10	-0.76	-0.71	-0.14
+4	0.60	0.13	0.03	-0.02	-0.09	0.17	0.05	-0.56	-0.42	0.02
+6	0.58	0.12	0.02	0.21	-0.03	0.19	0.15	-0.47	-0.75	-0.54
+8	0.57	0.11	0.00	0.16	-0.03	0.18	0.25	-0.37	-0.72	0.22
+10	0.54	0.08	-0.01	0.17	-0.01	0.13	-0.09	-0.30	-1.23	0.15
+11	0.53	0.08	-0.01	0.18	-0.01	0.13	-0.02	-0.22	-1.14	-0.03
+12	0.51	0.08	-0.01	0.18	-0.02	0.13	0.04	-0.13	-1.05	-0.21
+13	0.50	0.08	0.00	0.18	-0.03	0.14	0.08	-0.05	-0.94	-0.21
+14	0.49	0.09	0.00	0.18	-0.04	0.15	0.11	0.04	-0.82	-0.21
+15	0.46	0.07	-0.01	0.16	-0.04	0.15	0.20	0.10	-0.72	-0.07
+16	0.43	0.05	-0.03	0.15	-0.04	0.15	0.28	0.17	-0.63	0.06
+17	0.37	0.02	-0.05	0.15	-0.05	0.13	0.40	-0.05	-0.61	0.06
+18	0.31	0.00	-0.07	0.14	-0.06	0.12	0.51	-0.28	-0.60	0.06
+19	0.23	-0.04	-0.08	0.13	-0.06	0.11	0.36	-0.17	-0.43	-0.15
+20	0.15	-0.07	-0.09	0.12	-0.06	0.09	0.22	-0.06	-0.26	-0.35
+21	0.06	-0.14	-0.12	0.11	-0.08	0.04	0.33	-0.05	-0.45	-0.71
+22	-0.02	-0.22	-0.15	0.11	-0.11	-0.02	0.45	-0.05	-0.64	-1.06
+23	-0.20	-0.13	-0.24	0.06	-0.16	0.08	0.26	-0.31	-0.78	--
+24	-0.37	-0.04	-0.32	0.01	-0.22	0.18	0.07	-0.57	-0.92	--
+25	-0.52	0.24	-0.17	0.08	-0.18	0.06	-0.40	-1.09	-1.30	--

Frequency Extender

FX-30GHP-RC

Typical Performance Data

Test Conditions: @ Temperature = 0°C.

Freq. (GHz)	Harmonics levels vs. Output Frequency (dBc)									
	-45 dBm					-20 dBm				
	F2	F3	F0.5	F1.5	F2.5	F2	F3	F0.5	F1.5	F2.5
0.05	-46.04	-66.43	--	--	--	-44.14	-64.52	--	--	--
0.50	-39.69	-63.80	--	--	--	-39.41	-63.74	--	--	--
1.25	-44.95	-63.52	--	--	--	-46.45	-83.01	--	--	--
2.00	-64.16	-67.59	--	--	--	-51.23	-76.13	--	--	--
2.75	-64.21	-66.99	--	--	--	-47.11	-79.27	--	--	--
3.50	-65.88	-64.11	--	--	--	-49.59	-79.60	--	--	--
4.25	-65.87	-67.45	--	--	--	-43.37	-75.45	--	--	--
5.00	-63.46	-69.34	--	--	--	-43.53	-73.77	--	--	--
5.75	-64.70	-63.84	--	--	--	-45.93	-79.69	--	--	--
6.50	-64.31	-59.55	--	--	--	-43.09	-71.51	--	--	--
7.25	-64.66	-59.68	--	--	--	-70.68	-77.85	--	--	--
8.00	-72.01	-60.92	--	--	--	-72.11	-72.35	--	--	--
8.75	-62.17	-56.34	--	--	--	-73.89	-71.42	--	--	--
9.50	-60.32	-57.05	--	--	--	-70.66	-75.96	--	--	--
10.25	-59.76	-56.47	--	--	--	-72.19	-70.07	--	--	--
11.00	-62.12	-52.70	--	--	--	-71.55	-69.83	--	--	--
11.50	-61.09	-54.73	--	--	--	-71.58	-68.49	--	--	--
12.00	-67.24	-50.91	--	--	--	-69.98	-68.14	--	--	--
12.50	-61.36	-58.80	--	--	--	-67.98	-74.74	--	--	--
13.00	-54.20	-54.80	--	--	--	-71.35	-75.87	--	--	--
13.50	-57.43	-52.35	--	--	--	-67.05	-70.88	--	--	--
14.00	-61.87	-48.26	--	--	--	-69.76	-70.17	--	--	--
14.50	-59.54	-55.31	--	--	--	-67.82	-66.24	--	--	--
15.00	-58.80	-48.19	-68.15	-61.58	-59.64	-65.03	-64.27	-77.55	-74.45	-70.52
15.50	-36.36	-29.82	-28.39	-25.01	-46.31	-56.52	-58.80	-53.55	-53.24	-63.76
16.00	-41.27	-38.01	-16.48	-30.19	-42.45	-49.55	-58.67	-43.10	-57.41	-69.43
16.50	-42.58	-34.09	-24.13	-32.45	-48.31	-41.24	-47.48	-50.16	-58.26	-72.37
17.00	-37.54	--	-23.39	-39.25	-51.51	-33.37	--	-47.26	-62.77	-66.19
17.50	-35.03	--	-12.24	-41.38	-43.56	-37.55	--	-39.72	-69.92	-66.50
18.00	-33.11	--	-19.21	-53.34	-34.47	-40.79	--	-43.45	-71.96	-55.71
18.75	-43.02	--	-14.41	-49.13	-31.14	-44.31	--	-40.71	-66.62	-57.35
19.50	-34.20	--	-18.53	-49.95	-40.03	-47.40	--	-44.68	-73.44	-61.16
20.25	-37.77	--	-15.82	-41.78	--	-46.21	--	-39.98	-65.38	--
21.00	-37.55	--	-13.06	-51.69	--	-41.02	--	-35.75	-74.97	--
21.75	-37.54	--	-19.86	-51.00	--	-39.87	--	-44.96	-73.17	--
22.50	-21.24	--	-20.44	-55.82	--	-38.58	--	-44.02	-72.66	--
23.25	-22.33	--	-7.03	-47.84	--	-39.61	--	-32.90	-66.89	--
24.00	-34.53	--	4.34	-50.49	--	-38.31	--	-21.05	-62.51	--
24.75	-25.83	--	1.67	-44.46	--	-36.34	--	-23.54	-65.51	--
25.50	--	--	9.39	-45.86	--	--	--	-15.62	-67.13	--
26.25	--	--	5.58	-43.73	--	--	--	-19.64	-66.70	--
27.00	--	--	10.34	-43.28	--	--	--	-13.75	-68.44	--
27.75	--	--	8.25	-38.84	--	--	--	-16.79	-58.55	--
28.50	--	--	7.77	-40.89	--	--	--	-17.81	-63.97	--
29.25	--	--	-1.76	-45.92	--	--	--	-28.91	-66.55	--
30.00	--	--	9.97	-30.69	--	--	--	-15.58	-57.48	--

Note: No sub-harmonics below 15 GHz.

Frequency Extender

FX-30GHP-RC

Typical Performance Data

Test Conditions: @ Temperature = 0°C.

Freq. (GHz)	Harmonics levels vs. Output Frequency (dBc)									
	+10 dBm					+20 dBm				
	F2	F3	F0.5	F1.5	F2.5	F2	F3	F0.5	F1.5	F2.5
0.05	-35.33	-60.74	--	--	--	-26.20	-44.84	--	--	--
0.50	-40.39	-58.58	--	--	--	-27.79	-47.55	--	--	--
1.25	-36.23	-76.50	--	--	--	-28.36	-57.11	--	--	--
2.00	-40.82	-67.74	--	--	--	-29.18	-52.74	--	--	--
2.75	-38.86	-66.31	--	--	--	-27.36	-49.46	--	--	--
3.50	-38.29	-66.85	--	--	--	-26.85	-48.94	--	--	--
4.25	-39.02	-64.73	--	--	--	-27.47	-46.09	--	--	--
5.00	-38.68	-66.15	--	--	--	-27.40	-45.02	--	--	--
5.75	-38.57	-70.11	--	--	--	-27.53	-50.30	--	--	--
6.50	-39.71	-71.29	--	--	--	-28.62	-48.62	--	--	--
7.25	-40.91	-68.07	--	--	--	-29.60	-46.61	--	--	--
8.00	-41.33	-68.42	--	--	--	-29.89	-44.46	--	--	--
8.75	-42.86	-66.66	--	--	--	-31.30	-43.72	--	--	--
9.50	-44.35	-72.04	--	--	--	-32.69	-47.10	--	--	--
10.25	-43.28	-68.05	--	--	--	-31.67	-46.58	--	--	--
11.00	-41.78	-65.62	--	--	--	-29.89	-42.54	--	--	--
11.50	-40.58	-71.63	--	--	--	-28.81	-45.38	--	--	--
12.00	-40.98	-70.19	--	--	--	-29.08	-45.25	--	--	--
12.50	-39.03	-69.44	--	--	--	-27.48	-43.30	--	--	--
13.00	-37.63	-67.02	--	--	--	-25.77	-42.18	--	--	--
13.50	-38.36	-69.49	--	--	--	-26.34	-42.10	--	--	--
14.00	-38.43	-69.28	--	--	--	-26.32	-41.63	--	--	--
14.50	-40.13	-68.39	--	--	--	-28.48	-43.55	--	--	--
15.00	-40.35	-70.55	-91.40	-87.24	-81.18	-28.80	-43.64	-91.95	-98.37	-89.95
15.50	-39.00	-63.13	-81.40	-77.51	-80.06	-21.48	-38.57	-88.20	-85.45	-87.51
16.00	-33.67	-62.65	-72.33	-87.27	-79.14	-18.06	-33.70	-81.71	-95.82	-90.44
16.50	-33.68	-63.25	-81.16	-89.38	-78.51	-17.86	-32.42	-92.43	-85.10	-89.51
17.00	-32.07	--	-75.57	-82.80	-74.26	-17.28	--	-83.74	-78.23	-86.89
17.50	-34.50	--	-69.81	-81.52	-75.25	-21.34	--	-79.76	-88.12	-87.66
18.00	-34.92	--	-70.90	-84.04	-75.81	-21.62	--	-80.67	-83.66	-83.24
18.75	-34.58	--	-69.90	-82.67	-77.51	-21.44	--	-78.71	-92.85	-83.58
19.50	-34.96	--	-76.33	-81.38	-70.57	-22.07	--	-86.57	-90.11	-82.71
20.25	-34.77	--	-63.80	-81.71	--	-21.23	--	-61.91	-71.19	--
21.00	-33.92	--	-56.76	-82.96	--	-20.65	--	-62.54	-74.45	--
21.75	-36.32	--	-61.36	-79.50	--	-22.40	--	-61.66	-73.31	--
22.50	-37.70	--	-63.04	-82.65	--	-24.29	--	-60.62	-72.08	--
23.25	-38.68	--	-52.40	-76.83	--	-25.18	--	-55.91	-72.80	--
24.00	-38.66	--	-49.02	-81.88	--	-25.60	--	-56.58	-73.54	--
24.75	-37.32	--	-60.12	-79.74	--	-22.98	--	-61.44	-70.80	--
25.50	--	--	-45.98	-78.66	--	--	--	-56.08	-79.97	--
26.25	--	--	-50.07	-80.50	--	--	--	-60.11	-80.94	--
27.00	--	--	-43.72	-75.99	--	--	--	-51.85	-73.81	--
27.75	--	--	-45.51	-75.60	--	--	--	-52.10	-71.57	--
28.50	--	--	-45.36	-71.88	--	--	--	-49.91	-69.83	--
29.25	--	--	-61.42	-74.47	--	--	--	-55.59	-69.93	--
30.00	--	--	-46.68	-76.58	--	--	--	-58.72	-77.81	--

Note: No sub-harmonics below 15 GHz.

Frequency Extender

FX-30GHP-RC

Typical Performance Data

Test Conditions: @ Temperature = 25°C.

Freq. (GHz)	Power deviation from nominal vs. Output Frequency (dB)									
	-35 dBm	-28 dBm	-21 dBm	-14 dBm	-7 dBm	0 dBm	+7 dBm	+14 dBm	+21 dBm	+25 dBm
0.05	-0.03	0.00	-0.04	0.30	0.22	0.20	0.12	0.01	-0.42	-0.93
0.50	-0.04	-0.05	-0.02	0.09	0.03	0.01	-0.03	-0.09	-0.35	0.06
1.25	0.33	0.35	0.41	0.12	0.11	0.14	0.06	0.06	-0.09	-0.21
2.00	-0.14	-0.10	-0.15	0.16	0.10	0.14	0.10	0.04	-0.25	-0.07
2.75	-0.15	-0.14	-0.13	0.01	-0.01	-0.01	-0.04	-0.02	-0.14	0.11
3.50	-0.12	-0.12	-0.10	-0.01	0.01	0.01	-0.04	0.00	-0.12	-0.20
4.25	-0.06	-0.15	-0.10	-0.03	0.03	0.05	-0.18	0.00	-0.08	-0.19
5.00	-0.51	-0.82	-0.59	-0.86	-0.93	-0.53	-0.53	0.10	0.19	0.11
5.75	-0.10	-0.17	-0.22	-0.02	0.00	0.04	-0.13	-0.07	-0.13	-0.22
6.50	0.05	0.05	0.04	0.00	0.05	0.05	-0.09	0.00	-0.09	-0.22
7.25	-0.29	-0.29	-0.24	-0.17	-0.12	-0.09	-0.22	-0.15	-0.24	-0.40
8.00	0.24	0.25	0.18	0.08	0.16	0.20	0.07	0.16	0.08	-0.08
8.75	-0.32	-0.28	-0.01	-0.06	-0.02	0.05	-0.08	-0.03	-0.11	-0.20
9.50	-0.24	-0.24	-0.19	-0.27	-0.22	-0.21	-0.35	-0.25	-0.27	-0.34
10.25	-0.06	-0.06	-0.12	-0.21	-0.16	-0.16	-0.27	-0.19	-0.19	-0.27
11.00	0.37	0.40	0.20	0.09	0.14	0.18	0.10	0.17	0.13	0.06
11.50	-0.05	-0.07	0.05	0.11	0.15	0.15	0.07	0.11	-0.02	-0.17
12.00	-0.23	-0.20	-0.09	-0.03	0.01	0.03	-0.10	-0.01	-0.10	-0.22
12.50	0.04	-0.09	0.01	-0.07	-0.04	-0.03	-0.14	-0.10	-0.21	-0.41
13.00	0.03	-0.02	0.24	0.18	0.23	0.26	0.15	0.23	0.05	-0.28
13.50	-0.02	-0.07	0.17	0.16	0.19	0.18	0.10	0.18	0.06	-0.19
14.00	-0.23	-0.32	-0.14	-0.23	-0.19	-0.20	-0.31	-0.24	-0.37	-0.60
14.50	0.09	-0.02	0.07	0.03	0.07	-0.05	-0.11	-0.10	-0.20	-0.54
15.00	0.36	0.26	0.27	0.20	0.24	0.14	0.04	0.11	-0.07	-0.26
15.50	-0.64	-0.09	-0.09	-0.31	-0.13	-0.29	-0.68	-0.40	-0.09	-0.24
16.00	0.49	0.61	0.38	0.59	0.41	0.25	0.14	0.21	0.32	0.28
16.50	0.73	0.54	0.41	0.14	0.40	0.25	0.46	0.18	0.38	0.12
17.00	1.18	0.83	0.48	0.52	0.71	-0.04	0.24	0.55	0.45	0.05
17.50	0.35	0.52	0.43	0.26	-0.04	-0.29	0.22	0.20	0.59	-0.13
18.00	0.85	0.45	0.35	0.21	0.11	-0.38	0.04	-0.03	0.37	-0.15
18.75	-0.30	-0.25	-0.19	-0.29	0.01	-0.54	-0.10	-0.18	-0.04	-0.07
19.50	-1.31	-0.65	0.19	-0.46	-0.16	0.02	-0.05	0.14	-0.07	-0.25
20.25	0.99	0.76	1.07	0.56	0.21	0.42	0.03	0.22	0.08	-0.30
21.00	1.01	0.47	0.50	-0.16	0.06	-0.23	-0.13	-0.25	0.04	-0.86
21.75	0.84	0.35	0.44	0.30	-0.04	0.01	0.04	-0.19	0.05	-0.50
22.50	0.19	0.27	0.35	-0.14	-0.06	0.14	-0.37	-0.31	0.06	-0.49
23.25	0.18	-0.11	0.00	-0.16	-0.35	-0.21	-0.39	-0.12	-0.17	-0.74
24.00	0.18	0.11	0.04	-0.09	-0.30	0.15	-0.19	0.22	-0.20	-0.47
24.75	0.60	0.63	0.58	-0.15	-0.01	0.20	0.25	0.44	0.01	-0.37
25.50	0.38	-0.14	-0.02	0.04	-0.22	-0.07	-0.13	-0.43	0.17	-0.55
26.25	0.06	0.15	-0.07	-0.26	-0.10	-0.17	-0.18	0.24	0.27	-0.74
27.00	0.32	0.28	0.19	0.01	0.30	0.42	0.02	0.46	0.23	-1.02
27.75	-0.08	-0.03	-0.12	-0.57	-0.10	-0.17	0.15	0.15	0.39	--
28.50	0.22	0.32	0.15	-0.19	0.00	0.05	0.21	0.26	0.13	--
29.25	0.27	0.18	-0.06	-0.47	-0.17	-0.33	-0.30	-0.65	-0.32	--
30.00	0.12	0.29	0.28	0.12	0.16	0.09	0.30	0.58	-0.47	--

Frequency Extender

FX-30GHP-RC

Typical Performance Data

Test Conditions: @ Temperature = 25°C.

Power (dBm)	Power deviation from nominal vs. Output Power (dBm)									
	0.05 GHz	0.5 GHz	1 GHz	5 GHz	10 GHz	15 GHz	17.8 GHz	21.2 GHz	27 GHz	30 GHz
-35	-0.03	-0.04	-0.15	-0.51	0.09	0.36	0.73	0.30	0.32	0.12
-34	-0.03	-0.04	-0.14	-0.52	0.08	0.36	0.76	0.35	0.40	0.23
-33	-0.03	-0.04	-0.14	-0.52	0.05	0.36	0.80	0.35	0.30	0.22
-32	-0.02	-0.04	-0.15	-0.52	0.02	0.35	0.85	0.36	0.20	0.21
-31	-0.02	-0.05	-0.15	-0.51	0.04	0.30	0.64	0.34	0.30	0.22
-30	-0.02	-0.07	-0.16	-0.49	0.05	0.24	0.44	0.32	0.41	0.22
-29	-0.01	-0.06	-0.15	-0.65	0.04	0.25	0.49	0.30	0.35	0.25
-28	0.00	-0.05	-0.14	-0.82	0.04	0.26	0.54	0.29	0.28	0.29
-27	0.00	-0.05	-0.14	-0.83	0.04	0.25	0.54	0.34	0.32	0.09
-26	-0.01	-0.05	-0.14	-0.84	0.03	0.23	0.54	0.39	0.37	-0.10
-25	-0.04	-0.05	-0.15	-0.87	0.03	0.23	0.60	0.40	0.19	0.04
-24	-0.06	-0.05	-0.15	-0.91	0.02	0.22	0.66	0.41	0.01	0.18
-23	-0.03	-0.02	-0.13	-0.84	-0.04	0.24	0.33	0.37	0.15	0.25
-22	0.00	0.01	-0.10	-0.78	-0.09	0.26	0.01	0.32	0.29	0.32
-21	-0.04	-0.02	-0.10	-0.59	-0.08	0.27	0.18	0.41	0.19	0.28
-20	-0.07	-0.06	-0.10	-0.41	-0.06	0.28	0.34	0.50	0.09	0.24
-18	-0.03	-0.02	-0.07	-0.31	0.00	0.31	-0.02	0.85	0.15	0.19
-16	-0.09	-0.06	-0.12	-0.33	-0.09	0.27	-0.02	0.75	0.09	0.09
-14	0.30	0.09	0.02	-0.86	-0.02	0.20	-0.10	-0.11	0.01	0.12
-12	0.28	0.08	0.04	-0.76	0.01	0.23	-0.05	-0.04	0.15	0.06
-10	0.29	0.09	0.07	-0.91	0.05	0.19	0.07	-0.06	0.14	0.15
-8	0.24	0.04	0.03	-0.99	0.05	0.23	0.09	-0.01	0.33	0.09
-6	0.21	0.03	0.01	-0.87	0.01	0.26	0.18	0.16	0.28	0.23
-4	0.19	0.02	0.02	-0.42	0.05	0.26	-0.29	0.24	0.34	0.17
-2	0.21	0.04	0.04	-0.51	0.09	0.29	-0.21	0.17	0.29	-0.01
0	0.20	0.01	0.03	-0.53	0.08	0.14	-0.19	-0.16	0.42	0.09
+2	0.19	0.02	0.03	-0.59	0.08	0.16	-0.06	-0.08	0.06	0.12
+4	0.19	0.02	0.03	-0.57	0.00	0.15	0.04	-0.02	0.22	0.00
+6	0.17	0.00	-0.01	-0.64	-0.03	0.03	0.22	-0.10	0.13	0.33
+8	0.08	-0.07	-0.04	-0.42	-0.05	0.04	-0.22	-0.07	-0.10	0.27
+10	0.06	-0.10	-0.05	-0.33	-0.09	-0.07	-0.13	-0.13	-0.07	0.23
+11	0.06	-0.08	-0.03	-0.20	-0.09	-0.09	-0.12	-0.05	0.11	0.29
+12	0.06	-0.06	-0.01	-0.06	-0.08	-0.11	-0.11	0.03	0.28	0.35
+13	0.04	-0.08	-0.03	0.02	-0.01	0.00	0.03	0.15	0.37	0.46
+14	0.01	-0.09	-0.04	0.10	0.06	0.11	0.17	0.28	0.46	0.58
+15	-0.03	-0.12	-0.07	0.08	0.04	0.09	0.21	0.25	0.15	0.56
+16	-0.07	-0.16	-0.09	0.06	0.02	0.07	0.26	0.21	-0.17	0.54
+17	-0.12	-0.17	-0.11	0.13	0.02	0.05	0.08	0.03	-0.05	0.53
+18	-0.16	-0.18	-0.12	0.20	0.01	0.03	-0.09	-0.15	0.07	0.51
+19	-0.24	-0.23	-0.13	0.19	-0.01	0.01	-0.04	-0.05	0.17	0.26
+20	-0.32	-0.27	-0.15	0.18	-0.02	-0.02	0.01	0.05	0.27	0.00
+21	-0.42	-0.35	-0.18	0.19	-0.03	-0.07	0.14	-0.01	0.23	-0.47
+22	-0.51	-0.43	-0.21	0.20	-0.04	-0.11	0.27	-0.07	0.18	-0.94
+23	-0.65	-0.33	-0.29	0.13	-0.11	-0.08	0.18	-0.18	-0.05	--
+24	-0.79	-0.23	-0.38	0.06	-0.18	-0.05	0.10	-0.30	-0.29	--
+25	-0.93	0.06	-0.23	0.11	-0.11	-0.26	-0.14	-0.94	-1.02	--

Frequency Extender

FX-30GHP-RC

Typical Performance Data

Test Conditions: @ Temperature = 25°C.

Freq. (GHz)	Harmonics levels vs. Output Frequency (dBc)									
	-45 dBm					-20 dBm				
	F2	F3	F0.5	F1.5	F2.5	F2	F3	F0.5	F1.5	F2.5
0.05	-44.04	-67.43	--	--	--	-43.38	-63.66	--	--	--
0.50	-39.41	-66.29	--	--	--	-39.28	-63.86	--	--	--
1.25	-43.78	-66.69	--	--	--	-45.89	-80.76	--	--	--
2.00	-63.59	-63.84	--	--	--	-50.07	-75.53	--	--	--
2.75	-65.79	-70.34	--	--	--	-46.32	-78.33	--	--	--
3.50	-70.01	-68.08	--	--	--	-48.92	-79.32	--	--	--
4.25	-65.77	-63.74	--	--	--	-43.15	-73.16	--	--	--
5.00	-67.86	-66.76	--	--	--	-43.03	-77.07	--	--	--
5.75	-64.23	-63.86	--	--	--	-45.36	-76.81	--	--	--
6.50	-72.22	-63.03	--	--	--	-42.93	-70.20	--	--	--
7.25	-62.41	-62.30	--	--	--	-74.47	-76.38	--	--	--
8.00	-61.63	-60.93	--	--	--	-69.72	-77.78	--	--	--
8.75	-63.28	-56.40	--	--	--	-72.36	-74.45	--	--	--
9.50	-61.73	-56.90	--	--	--	-74.80	-73.22	--	--	--
10.25	-60.57	-58.56	--	--	--	-73.88	-73.90	--	--	--
11.00	-57.49	-58.44	--	--	--	-71.80	-75.22	--	--	--
11.50	-60.45	-57.97	--	--	--	-72.03	-70.03	--	--	--
12.00	-57.54	-53.51	--	--	--	-71.36	-66.22	--	--	--
12.50	-60.78	-54.32	--	--	--	-69.84	-68.98	--	--	--
13.00	-55.22	-54.41	--	--	--	-68.08	-69.31	--	--	--
13.50	-56.08	-56.72	--	--	--	-68.47	-70.10	--	--	--
14.00	-56.67	-54.67	--	--	--	-70.95	-71.02	--	--	--
14.50	-60.39	-51.39	--	--	--	-68.90	-63.99	--	--	--
15.00	-52.68	-46.84	-65.34	-57.55	-55.52	-71.32	-66.37	-85.07	-76.13	-75.02
15.50	-40.64	-34.01	-29.74	-26.10	-49.66	-60.43	-63.50	-54.60	-53.64	-69.56
16.00	-38.77	-39.00	-15.08	-31.05	-43.60	-58.85	-64.12	-42.00	-57.49	-66.93
16.50	-44.92	-38.63	-23.51	-34.53	-54.10	-64.43	-59.29	-48.88	-60.21	-70.94
17.00	-37.08	--	-23.29	-40.48	-53.67	-56.44	--	-46.14	-65.61	-70.87
17.50	-38.84	--	-9.84	-46.05	-40.72	-58.46	--	-36.59	-65.69	-67.05
18.00	-35.97	--	-19.85	-52.11	-37.48	-57.62	--	-42.72	-72.29	-58.63
18.75	-50.95	--	-13.54	-59.12	-35.29	-44.83	--	-39.28	-72.72	-58.56
19.50	-38.33	--	-17.35	-58.43	-41.39	-48.57	--	-44.39	-71.59	-63.81
20.25	-41.09	--	-15.19	-42.77	--	-46.12	--	-39.16	-69.00	--
21.00	-39.53	--	-12.20	-61.48	--	-41.45	--	-35.09	-75.55	--
21.75	-40.38	--	-18.86	-53.92	--	-40.09	--	-43.72	-75.14	--
22.50	-24.30	--	-21.32	-55.95	--	-38.52	--	-43.90	-74.15	--
23.25	-25.50	--	-7.06	-47.78	--	-38.73	--	-32.94	-70.64	--
24.00	-32.16	--	5.56	-45.85	--	-38.56	--	-20.30	-68.67	--
24.75	-29.20	--	2.08	-50.03	--	-37.25	--	-22.92	-67.53	--
25.50	--	--	8.58	-49.59	--	--	--	-15.95	-70.80	--
26.25	--	--	5.34	-45.09	--	--	--	-19.40	-66.45	--
27.00	--	--	10.16	-40.72	--	--	--	-14.15	-66.15	--
27.75	--	--	8.70	-38.87	--	--	--	-16.45	-60.61	--
28.50	--	--	7.96	-45.03	--	--	--	-18.30	-71.10	--
29.25	--	--	0.67	-41.78	--	--	--	-26.79	-65.22	--
30.00	--	--	10.74	-32.71	--	--	--	-14.60	-58.03	--

Note: No sub-harmonics below 15 GHz.

Frequency Extender

FX-30GHP-RC

Typical Performance Data

Test Conditions: @ Temperature = 25°C.

Freq. (GHz)	Harmonics levels vs. Output Frequency (dBc)									
	+10 dBm					+20 dBm				
	F2	F3	F0.5	F1.5	F2.5	F2	F3	F0.5	F1.5	F2.5
0.05	-36.26	-61.37	--	--	--	-27.32	-44.79	--	--	--
0.50	-41.41	-57.94	--	--	--	-28.38	-45.41	--	--	--
1.25	-36.51	-72.87	--	--	--	-28.64	-53.55	--	--	--
2.00	-40.58	-66.03	--	--	--	-29.00	-50.28	--	--	--
2.75	-38.72	-65.43	--	--	--	-27.32	-47.89	--	--	--
3.50	-38.33	-66.38	--	--	--	-26.93	-48.27	--	--	--
4.25	-39.63	-64.02	--	--	--	-28.17	-45.57	--	--	--
5.00	-38.75	-64.93	--	--	--	-27.56	-44.24	--	--	--
5.75	-38.83	-70.34	--	--	--	-27.76	-49.74	--	--	--
6.50	-39.93	-69.17	--	--	--	-28.82	-47.51	--	--	--
7.25	-40.67	-67.30	--	--	--	-29.40	-45.89	--	--	--
8.00	-41.23	-69.18	--	--	--	-29.88	-44.69	--	--	--
8.75	-43.28	-66.21	--	--	--	-31.92	-43.98	--	--	--
9.50	-44.21	-70.84	--	--	--	-32.51	-47.18	--	--	--
10.25	-42.60	-67.25	--	--	--	-30.96	-44.82	--	--	--
11.00	-40.85	-66.08	--	--	--	-29.04	-42.46	--	--	--
11.50	-40.09	-67.68	--	--	--	-28.43	-45.08	--	--	--
12.00	-40.40	-67.95	--	--	--	-28.61	-44.76	--	--	--
12.50	-38.75	-66.96	--	--	--	-27.35	-43.90	--	--	--
13.00	-37.75	-68.22	--	--	--	-26.10	-43.38	--	--	--
13.50	-38.36	-67.46	--	--	--	-26.61	-42.95	--	--	--
14.00	-38.69	-67.21	--	--	--	-26.74	-42.20	--	--	--
14.50	-39.07	-69.01	--	--	--	-27.33	-43.06	--	--	--
15.00	-39.80	-69.50	-95.72	-86.08	-83.29	-28.29	-43.37	-89.72	-93.72	-86.94
15.50	-36.85	-64.96	-81.61	-86.57	-73.87	-20.78	-37.02	-87.97	-89.94	-88.46
16.00	-33.27	-64.28	-72.73	-87.61	-79.00	-18.86	-34.94	-81.21	-93.66	-85.57
16.50	-33.50	-63.93	-82.58	-81.17	-77.94	-18.89	-33.93	-93.52	-86.25	-87.72
17.00	-31.74	--	-76.50	-86.89	-78.26	-18.56	--	-81.42	-81.14	-88.28
17.50	-34.15	--	-66.00	-82.12	-78.60	-20.97	--	-74.50	-88.52	-88.64
18.00	-34.20	--	-71.78	-82.58	-74.66	-21.54	--	-79.84	-87.23	-82.32
18.75	-35.13	--	-69.21	-83.08	-73.08	-22.28	--	-77.98	-93.29	-83.69
19.50	-35.62	--	-76.84	-84.43	-73.36	-23.23	--	-78.78	-86.05	-83.37
20.25	-35.53	--	-62.77	-79.31	--	-22.38	--	-62.58	-74.34	--
21.00	-34.23	--	-56.27	-81.90	--	-21.41	--	-64.20	-80.08	--
21.75	-36.08	--	-61.43	-84.30	--	-22.38	--	-61.05	-72.40	--
22.50	-37.60	--	-60.66	-84.24	--	-23.56	--	-59.50	-72.47	--
23.25	-38.14	--	-53.81	-79.51	--	-25.14	--	-57.68	-74.00	--
24.00	-38.48	--	-49.89	-74.48	--	-25.91	--	-59.09	-74.29	--
24.75	-37.85	--	-55.88	-81.15	--	-23.68	--	-58.32	-71.08	--
25.50	--	--	-46.98	-84.68	--	--	--	-58.17	-84.90	--
26.25	--	--	-50.15	-82.26	--	--	--	-59.46	-78.79	--
27.00	--	--	-43.92	-80.29	--	--	--	-51.29	-72.30	--
27.75	--	--	-45.45	-78.89	--	--	--	-51.09	-70.85	--
28.50	--	--	-45.71	-74.01	--	--	--	-49.80	-70.19	--
29.25	--	--	-58.91	-77.28	--	--	--	-55.37	-68.79	--
30.00	--	--	-45.64	-72.95	--	--	--	-57.09	-77.29	--

Note: No sub-harmonics below 15 GHz.

Frequency Extender

FX-30GHP-RC

Typical Performance Data

Test Conditions: @ Temperature = 50°C.

Freq. (GHz)	Power deviation from nominal vs. Output Frequency (dB)									
	-35 dBm	-28 dBm	-21 dBm	-14 dBm	-7 dBm	0 dBm	+7 dBm	+14 dBm	+21 dBm	+25 dBm
0.05	0.08	0.08	0.07	0.20	0.17	0.17	0.14	0.06	-0.38	-0.94
0.50	0.10	0.09	0.08	0.13	0.12	0.09	0.10	0.03	-0.24	0.06
1.25	0.14	0.16	0.21	0.09	0.07	0.07	0.04	0.02	-0.11	-0.27
2.00	-0.01	0.00	-0.04	0.09	0.01	-0.01	0.02	-0.05	-0.33	-0.23
2.75	-0.02	0.01	0.03	0.09	0.07	0.05	0.03	0.00	-0.10	0.05
3.50	0.12	0.12	0.16	0.11	0.11	0.07	0.03	-0.01	-0.12	-0.26
4.25	0.32	0.20	0.11	0.10	-0.15	-0.14	-0.18	-0.23	-0.42	-0.51
5.00	0.89	0.82	0.79	0.88	0.52	0.50	0.46	0.44	0.31	0.28
5.75	0.26	0.20	0.16	0.12	0.10	0.10	0.06	0.03	-0.05	-0.19
6.50	0.20	0.15	0.12	0.03	0.01	0.01	-0.03	-0.07	-0.22	-0.41
7.25	0.14	0.11	0.02	-0.01	-0.03	-0.03	-0.08	-0.10	-0.23	-0.45
8.00	0.37	0.29	0.19	0.08	0.06	0.07	0.04	0.03	-0.11	-0.30
8.75	0.05	-0.02	-0.05	-0.07	-0.10	-0.10	-0.11	-0.09	-0.24	-0.41
9.50	-0.01	-0.08	-0.11	-0.11	-0.13	-0.11	-0.19	-0.16	-0.29	-0.44
10.25	-0.01	-0.07	-0.08	-0.09	-0.24	-0.22	-0.27	-0.26	-0.37	-0.49
11.00	0.19	0.13	-0.02	0.02	-0.04	-0.04	-0.09	-0.04	-0.18	-0.35
11.50	0.19	0.14	-0.01	0.12	0.10	0.10	0.01	0.11	-0.11	-0.40
12.00	0.07	0.01	-0.17	-0.03	-0.12	-0.09	-0.12	-0.12	-0.30	-0.45
12.50	-0.02	-0.07	-0.28	-0.29	-0.34	-0.35	-0.34	-0.34	-0.59	-0.93
13.00	0.34	0.25	0.07	0.15	0.09	0.04	0.06	0.08	-0.21	-0.69
13.50	0.05	-0.04	-0.11	-0.04	-0.12	-0.16	-0.16	-0.17	-0.37	-0.74
14.00	0.31	0.19	-0.01	0.01	-0.08	-0.13	-0.12	-0.11	-0.33	-0.67
14.50	0.31	0.23	0.15	0.18	0.12	0.10	0.10	0.12	-0.06	-0.57
15.00	0.56	0.55	0.24	0.29	0.29	0.30	0.31	0.40	0.10	-0.56
15.50	-0.75	-0.17	-0.03	0.20	-0.10	0.07	-0.06	-0.19	-0.10	-0.64
16.00	-0.03	0.03	-0.31	0.04	-0.22	0.08	-0.39	-0.23	-0.32	0.71
16.50	-0.08	0.00	-0.19	0.23	-0.03	0.29	0.16	-0.05	0.17	0.59
17.00	0.50	0.23	0.21	0.11	0.05	-0.03	0.16	-0.14	-0.01	0.58
17.50	-0.09	0.06	-0.01	0.16	0.06	-0.02	0.16	-0.14	0.24	0.26
18.00	0.24	0.23	-0.27	-0.16	-0.01	-0.21	-0.44	-0.30	-0.13	0.30
18.75	-0.41	-0.46	-0.52	-0.79	-0.60	-0.48	-0.42	-0.38	-0.72	0.34
19.50	-1.48	-0.87	-0.79	-0.65	-0.51	-0.38	-0.13	-0.03	-0.39	0.43
20.25	-0.06	0.09	-0.23	0.03	-0.10	-0.27	-0.13	-0.04	-0.22	-0.17
21.00	0.51	0.18	-0.54	-0.55	-0.42	-0.32	-0.40	-0.52	-0.72	-0.45
21.75	0.26	-0.09	-0.33	0.11	0.17	-0.02	0.15	-0.15	0.26	-0.29
22.50	-0.10	-0.26	-0.34	-0.42	-0.45	0.22	-0.43	-0.39	-0.03	-0.32
23.25	-0.73	-0.63	-0.90	-0.45	-0.98	-0.50	-0.40	-0.20	-0.48	-0.12
24.00	-0.94	-1.13	-0.73	-0.53	-0.81	-0.07	-0.45	-0.42	-0.59	-0.20
24.75	0.07	-0.35	-0.39	0.00	-0.05	0.07	0.08	0.08	-0.17	0.21
25.50	0.44	-0.01	0.17	0.13	0.32	0.00	0.22	0.82	0.51	-0.16
26.25	0.02	-0.46	-0.22	-0.24	0.10	-0.02	0.85	0.61	0.73	-0.38
27.00	-0.11	-0.27	0.08	0.20	0.23	0.01	0.51	0.75	0.81	-1.03
27.75	-0.24	-0.16	-0.41	-0.30	-0.33	-0.58	0.46	0.02	0.67	--
28.50	0.21	0.23	0.13	0.39	0.03	0.00	0.88	0.33	0.90	--
29.25	0.06	-0.03	-0.23	-0.04	-0.03	-0.22	0.50	0.82	0.49	--
30.00	-0.03	0.04	-0.36	0.00	-0.19	-0.95	0.25	0.40	-0.02	--

Frequency Extender

FX-30GHP-RC

Typical Performance Data

Test Conditions: @ Temperature = 50°C.

Power (dBm)	Power deviation from nominal vs. Output Power (dBm)									
	0.05 GHz	0.5 GHz	1 GHz	5 GHz	10 GHz	15 GHz	17.8 GHz	21.2 GHz	27 GHz	30 GHz
-35	0.08	0.10	-0.10	0.89	0.03	0.56	0.07	0.09	-0.11	-0.03
-34	0.10	0.13	-0.07	0.92	0.03	0.54	0.09	0.13	-0.02	-0.06
-33	0.08	0.10	-0.09	0.92	-0.01	0.55	0.11	0.04	-0.18	-0.10
-32	0.06	0.07	-0.11	0.92	-0.04	0.56	0.14	-0.05	-0.33	-0.15
-31	0.09	0.09	-0.10	0.90	-0.04	0.56	0.16	-0.01	-0.35	-0.10
-30	0.11	0.11	-0.08	0.89	-0.05	0.56	0.18	0.03	-0.36	-0.05
-29	0.10	0.10	-0.09	0.86	-0.06	0.56	0.20	0.07	-0.32	-0.01
-28	0.08	0.09	-0.10	0.82	-0.06	0.55	0.23	0.11	-0.27	0.04
-27	0.06	0.08	-0.11	0.83	-0.06	0.40	0.02	0.15	-0.23	-0.18
-26	0.05	0.08	-0.13	0.83	-0.06	0.25	-0.19	0.19	-0.19	-0.39
-25	0.06	0.10	-0.09	0.81	-0.08	0.25	-0.13	0.09	0.00	-0.29
-24	0.08	0.13	-0.06	0.79	-0.09	0.24	-0.07	-0.01	0.19	-0.19
-23	0.08	0.11	-0.07	0.80	-0.12	0.24	0.01	0.02	0.25	-0.28
-22	0.08	0.09	-0.07	0.81	-0.15	0.25	0.10	0.05	0.31	-0.38
-21	0.07	0.08	-0.09	0.79	-0.14	0.24	-0.05	-0.01	0.08	-0.36
-20	0.07	0.08	-0.10	0.78	-0.13	0.23	-0.21	-0.07	-0.15	-0.34
-18	0.05	0.09	-0.10	0.80	-0.13	0.28	-0.09	-0.03	0.04	-0.41
-16	0.10	0.14	-0.05	0.84	-0.08	0.29	0.00	-0.35	-0.08	-0.24
-14	0.20	0.13	0.05	0.88	0.02	0.29	0.01	-0.31	0.20	0.00
-12	0.17	0.13	0.02	0.84	0.02	0.29	0.11	-0.37	0.23	-0.26
-10	0.18	0.12	0.04	0.87	0.04	0.30	0.08	-0.31	0.35	-0.29
-8	0.17	0.11	0.03	0.52	0.00	0.27	0.16	-0.22	0.15	-0.16
-6	0.18	0.13	0.04	0.52	-0.01	0.30	0.18	-0.15	0.31	-0.22
-4	0.18	0.13	0.03	0.51	-0.01	0.29	-0.48	-0.25	0.26	-0.45
-2	0.18	0.14	0.03	0.51	0.01	0.29	0.13	-0.18	0.38	-0.34
0	0.17	0.09	0.01	0.50	0.01	0.30	0.25	-0.11	0.01	-0.95
+2	0.15	0.10	0.02	0.46	-0.02	0.31	0.33	-0.03	0.07	0.21
+4	0.15	0.09	0.00	0.49	0.00	0.29	-0.06	-0.01	0.00	-0.01
+6	0.14	0.10	0.01	0.45	0.00	0.30	-0.03	-0.01	0.45	0.34
+8	0.13	0.10	-0.01	0.47	0.01	0.31	0.04	0.05	0.57	0.16
+10	0.12	0.07	-0.01	0.49	-0.02	0.41	0.08	0.17	0.74	0.24
+11	0.11	0.06	-0.01	0.48	-0.02	0.40	0.10	0.18	0.79	0.18
+12	0.11	0.05	-0.02	0.48	-0.02	0.39	0.13	0.20	0.84	0.12
+13	0.09	0.04	-0.03	0.46	-0.02	0.39	-0.10	-0.08	0.80	0.26
+14	0.06	0.03	-0.04	0.44	-0.01	0.40	-0.32	-0.36	0.75	0.40
+15	0.03	0.01	-0.06	0.42	-0.03	0.38	-0.29	-0.34	0.64	0.35
+16	0.00	0.00	-0.08	0.40	-0.04	0.37	-0.25	-0.32	0.53	0.29
+17	-0.06	-0.03	-0.10	0.41	-0.05	0.35	-0.23	-0.24	0.60	0.56
+18	-0.12	-0.06	-0.12	0.41	-0.07	0.33	-0.20	-0.16	0.68	0.83
+19	-0.20	-0.11	-0.13	0.39	-0.09	0.28	-0.15	-0.13	0.78	0.91
+20	-0.28	-0.15	-0.14	0.37	-0.12	0.23	-0.09	-0.09	0.87	1.00
+21	-0.38	-0.24	-0.17	0.31	-0.18	0.10	0.13	0.09	0.81	-0.02
+22	-0.48	-0.32	-0.19	0.25	-0.24	-0.03	0.35	0.28	0.75	-1.04
+23	-0.64	-0.25	-0.29	0.18	-0.31	-0.13	0.86	0.36	0.33	--
+24	-0.80	-0.18	-0.40	0.12	-0.38	-0.22	1.37	0.44	-0.08	--
+25	-0.94	0.06	-0.26	0.28	-0.38	-0.56	0.38	-0.53	-1.03	--

Frequency Extender

FX-30GHP-RC

Typical Performance Data

Test Conditions: @ Temperature = 50°C.

Freq. (GHz)	Harmonics levels vs. Output Frequency (dBc)									
	-45 dBm					-20 dBm				
	F2	F3	F0.5	F1.5	F2.5	F2	F3	F0.5	F1.5	F2.5
0.05	-45.45	-64.08	--	--	--	-44.75	-65.05	--	--	--
0.50	-39.37	-61.65	--	--	--	-39.32	-65.01	--	--	--
1.25	-44.59	-66.59	--	--	--	-46.54	-79.99	--	--	--
2.00	-69.72	-66.35	--	--	--	-49.26	-77.15	--	--	--
2.75	-65.35	-65.43	--	--	--	-45.85	-76.07	--	--	--
3.50	-67.02	-65.97	--	--	--	-48.52	-80.01	--	--	--
4.25	-63.63	-66.64	--	--	--	-42.61	-74.49	--	--	--
5.00	-65.72	-61.38	--	--	--	-43.27	-77.97	--	--	--
5.75	-64.32	-64.90	--	--	--	-45.15	-80.90	--	--	--
6.50	-65.45	-61.69	--	--	--	-42.46	-72.51	--	--	--
7.25	-64.40	-63.11	--	--	--	-72.09	-74.18	--	--	--
8.00	-62.38	-56.94	--	--	--	-76.51	-72.31	--	--	--
8.75	-63.87	-59.04	--	--	--	-76.38	-74.43	--	--	--
9.50	-63.58	-53.82	--	--	--	-75.29	-76.20	--	--	--
10.25	-65.07	-59.06	--	--	--	-72.17	-72.37	--	--	--
11.00	-60.18	-57.08	--	--	--	-71.95	-77.91	--	--	--
11.50	-58.85	-54.44	--	--	--	-67.66	-70.70	--	--	--
12.00	-60.86	-51.92	--	--	--	-71.04	-73.70	--	--	--
12.50	-59.94	-54.64	--	--	--	-68.73	-70.83	--	--	--
13.00	-56.95	-54.03	--	--	--	-67.76	-76.58	--	--	--
13.50	-61.68	-53.46	--	--	--	-66.10	-68.32	--	--	--
14.00	-60.10	-55.16	--	--	--	-76.29	-63.32	--	--	--
14.50	-64.92	-52.58	--	--	--	-68.27	-73.21	--	--	--
15.00	-60.39	-56.19	-68.00	-67.28	-50.62	-70.97	-69.06	-77.74	-77.11	-73.06
15.50	-43.20	-37.65	-31.35	-26.21	-47.38	-64.10	-58.92	-54.77	-54.40	-63.24
16.00	-38.67	-44.24	-17.06	-31.21	-48.09	-60.48	-63.60	-43.40	-56.59	-68.14
16.50	-39.16	-39.26	-24.22	-36.13	-45.83	-61.11	-63.64	-49.26	-60.96	-66.19
17.00	-39.03	--	-23.91	-41.13	-45.12	-58.25	--	-47.01	-64.72	-60.46
17.50	-39.89	--	-11.98	-46.55	-42.22	-62.74	--	-37.76	-69.50	-62.09
18.00	-39.90	--	-20.10	-53.82	-38.61	-61.60	--	-43.14	-68.91	-65.98
18.75	-50.64	--	-14.22	-57.34	-38.61	-45.19	--	-39.50	-71.86	-65.06
19.50	-37.66	--	-16.89	-53.79	-41.74	-48.66	--	-45.22	-72.68	-66.52
20.25	-47.26	--	-19.58	-48.51	--	-67.08	--	-43.29	-69.31	--
21.00	-44.83	--	-12.29	-59.20	--	-58.90	--	-32.88	-68.82	--
21.75	-43.29	--	-18.32	-58.48	--	-55.29	--	-40.70	-72.05	--
22.50	-28.02	--	-23.60	-54.43	--	-57.11	--	-51.91	-70.48	--
23.25	-29.35	--	-7.94	-48.09	--	-39.20	--	-33.14	-68.81	--
24.00	-33.79	--	4.73	-48.02	--	-56.68	--	-19.03	-67.22	--
24.75	-31.99	--	1.22	-51.03	--	-54.14	--	-22.60	-67.87	--
25.50	--	--	6.51	-49.90	--	--	--	-17.55	-67.88	--
26.25	--	--	3.87	-48.92	--	--	--	-20.31	-67.68	--
27.00	--	--	8.83	-41.89	--	--	--	-15.85	-62.19	--
27.75	--	--	6.94	-39.05	--	--	--	-18.30	-63.77	--
28.50	--	--	7.50	-52.77	--	--	--	-18.41	-67.59	--
29.25	--	--	-0.39	-47.08	--	--	--	-26.80	-65.75	--
30.00	--	--	10.94	-35.27	--	--	--	-14.50	-65.42	--

Note: No sub-harmonics below 15 GHz.

Frequency Extender

FX-30GHP-RC

Typical Performance Data

Test Conditions: @ Temperature = 50°C.

Freq. (GHz)	Harmonics levels vs. Output Frequency (dBc)									
	+10 dBm					+21 dBm				
	F2	F3	F0.5	F1.5	F2.5	F2	F3	F0.5	F1.5	F2.5
0.05	-36.59	-64.75	--	--	--	-27.16	-42.03	--	--	--
0.50	-41.30	-57.39	--	--	--	-27.33	-41.67	--	--	--
1.25	-36.83	-69.87	--	--	--	-27.93	-49.12	--	--	--
2.00	-40.91	-64.93	--	--	--	-28.03	-46.39	--	--	--
2.75	-39.19	-64.70	--	--	--	-26.59	-44.53	--	--	--
3.50	-38.78	-65.71	--	--	--	-26.32	-45.62	--	--	--
4.25	-40.33	-63.60	--	--	--	-27.81	-42.80	--	--	--
5.00	-39.97	-65.86	--	--	--	-27.60	-42.48	--	--	--
5.75	-38.89	-68.69	--	--	--	-26.52	-46.68	--	--	--
6.50	-40.07	-67.95	--	--	--	-27.74	-45.38	--	--	--
7.25	-41.34	-66.62	--	--	--	-28.76	-43.93	--	--	--
8.00	-41.27	-67.85	--	--	--	-28.87	-42.48	--	--	--
8.75	-43.27	-65.29	--	--	--	-30.99	-41.82	--	--	--
9.50	-44.04	-68.49	--	--	--	-30.91	-43.52	--	--	--
10.25	-42.12	-66.46	--	--	--	-29.15	-42.47	--	--	--
11.00	-41.04	-65.90	--	--	--	-28.04	-40.48	--	--	--
11.50	-39.89	-68.21	--	--	--	-26.78	-42.33	--	--	--
12.00	-40.13	-67.77	--	--	--	-27.11	-42.83	--	--	--
12.50	-38.01	-67.46	--	--	--	-25.19	-40.66	--	--	--
13.00	-37.36	-68.04	--	--	--	-24.54	-41.48	--	--	--
13.50	-37.69	-66.35	--	--	--	-24.70	-39.47	--	--	--
14.00	-38.13	-66.54	--	--	--	-24.97	-40.68	--	--	--
14.50	-38.15	-67.32	--	--	--	-25.18	-40.90	--	--	--
15.00	-38.74	-67.83	-91.47	-88.47	-81.29	-25.89	-39.90	-92.05	-101.90	-94.22
15.50	-35.69	-66.68	-83.56	-85.15	-75.96	-19.31	-35.43	-91.15	-91.79	-84.52
16.00	-32.85	-63.89	-73.08	-85.32	-78.07	-17.75	-32.68	-83.18	-95.06	-89.27
16.50	-33.14	-63.13	-80.77	-79.98	-78.03	-17.91	-32.49	-94.55	-92.41	-86.29
17.00	-32.43	--	-76.23	-86.97	-73.86	-18.09	--	-83.04	-86.65	-88.40
17.50	-34.60	--	-66.90	-86.33	-80.08	-20.23	--	-76.01	-92.06	-86.47
18.00	-35.51	--	-72.10	-80.56	-78.04	-21.43	--	-81.06	-86.93	-90.30
18.75	-35.65	--	-69.90	-82.36	-76.44	-22.08	--	-79.56	-93.77	-84.49
19.50	-36.65	--	-78.30	-81.91	-77.01	-23.46	--	-74.51	-84.51	-86.91
20.25	-35.49	--	-64.66	-86.08	--	-21.00	--	-63.01	-74.20	--
21.00	-36.15	--	-56.78	-81.09	--	-22.32	--	-65.52	-80.97	--
21.75	-36.47	--	-60.67	-79.73	--	-21.36	--	-59.37	-70.78	--
22.50	-37.61	--	-58.73	-85.40	--	-22.59	--	-58.39	-70.15	--
23.25	-38.45	--	-55.09	-80.24	--	-24.24	--	-59.96	-77.34	--
24.00	-37.74	--	-51.49	-81.67	--	-23.48	--	-61.30	-72.86	--
24.75	-38.52	--	-55.97	-79.11	--	-23.05	--	-56.64	-68.97	--
25.50	--	--	-48.75	-76.89	--	--	--	-62.25	-83.46	--
26.25	--	--	-50.94	-78.72	--	--	--	-58.77	-77.12	--
27.00	--	--	-45.08	-78.24	--	--	--	-51.77	-71.81	--
27.75	--	--	-46.44	-80.18	--	--	--	-52.23	-73.20	--
28.50	--	--	-46.38	-76.19	--	--	--	-55.62	-78.94	--
29.25	--	--	-56.70	-75.43	--	--	--	-64.21	-75.31	--
30.00	--	--	-44.67	-72.67	--	--	--	-53.66	-81.55	--

Note: No sub-harmonics below 15 GHz.

Frequency Extender

FX-30GHP-RC

Typical Performance Curves

Test Conditions: @ Temperature = 0°C.

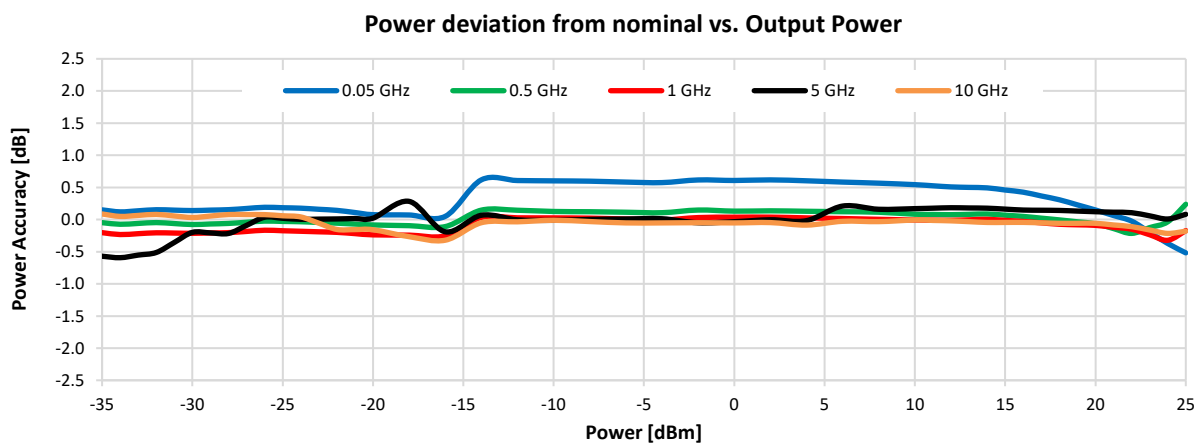
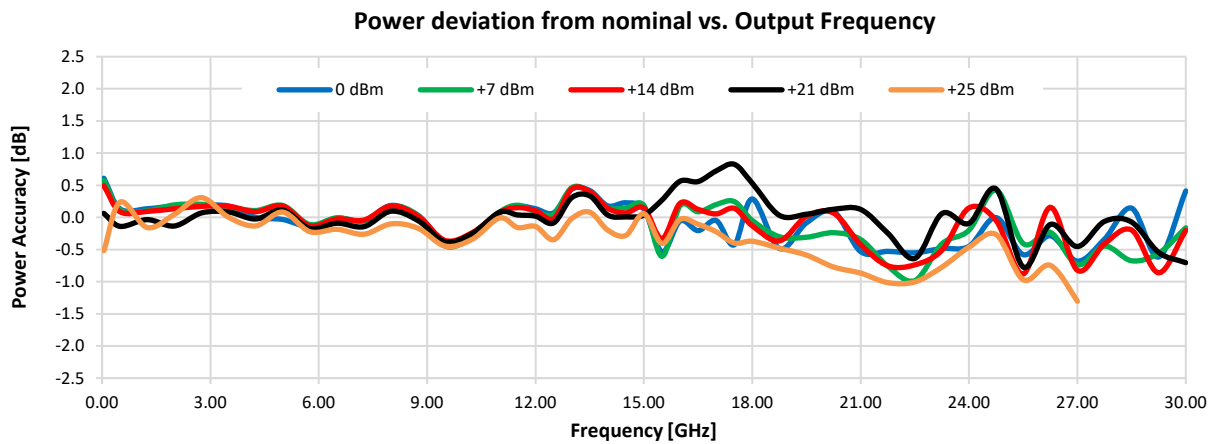
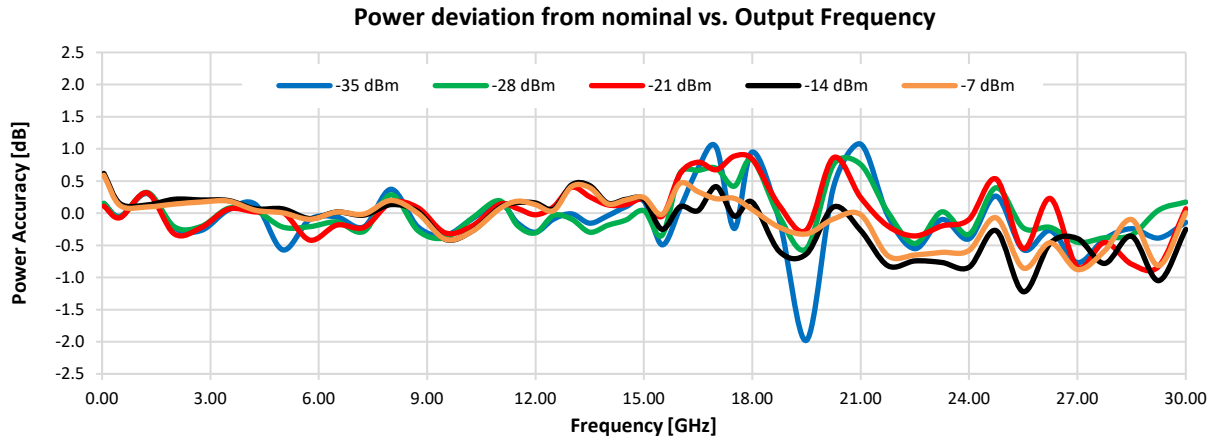

Frequency Extender

FX-30GHP-RC

Typical Performance Curves

Test Conditions: @ Temperature = 0°C.

Power deviation from nominal vs. Output Power

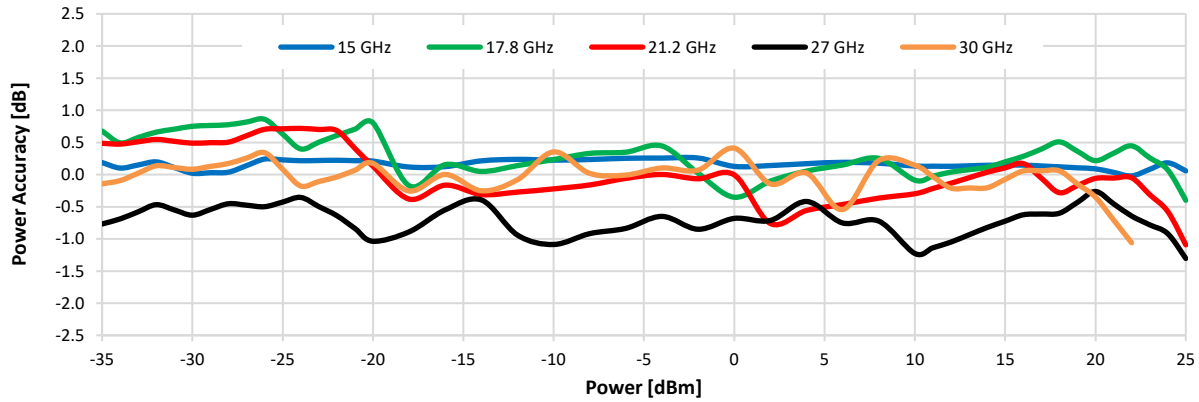

Harmonics (F2) vs. Output Frequency

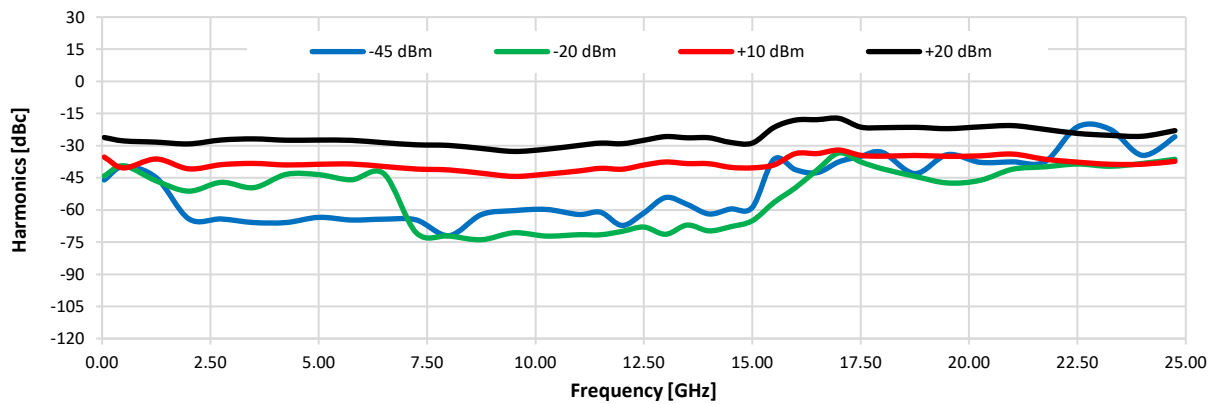

Harmonics (F3) vs. Output Frequency

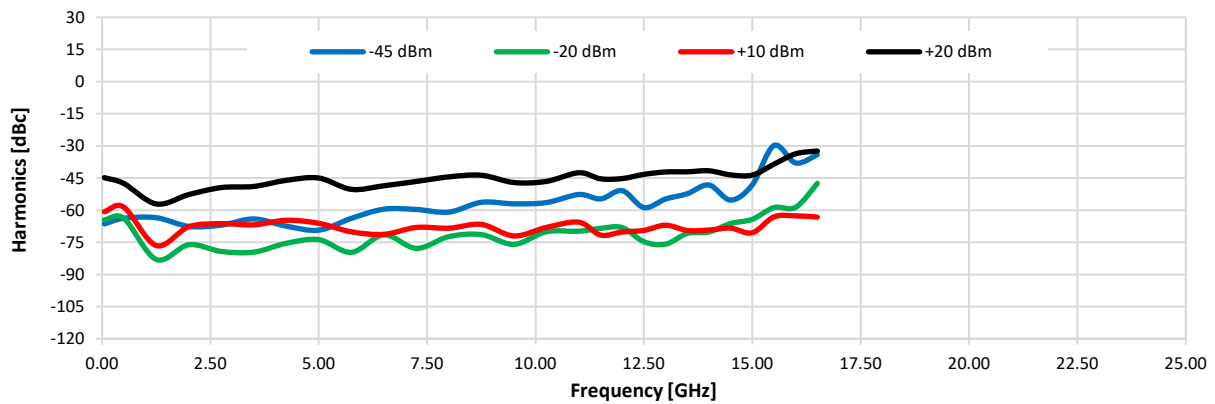

Typical Performance Curves

Test Conditions: @ Temperature = 0°C.

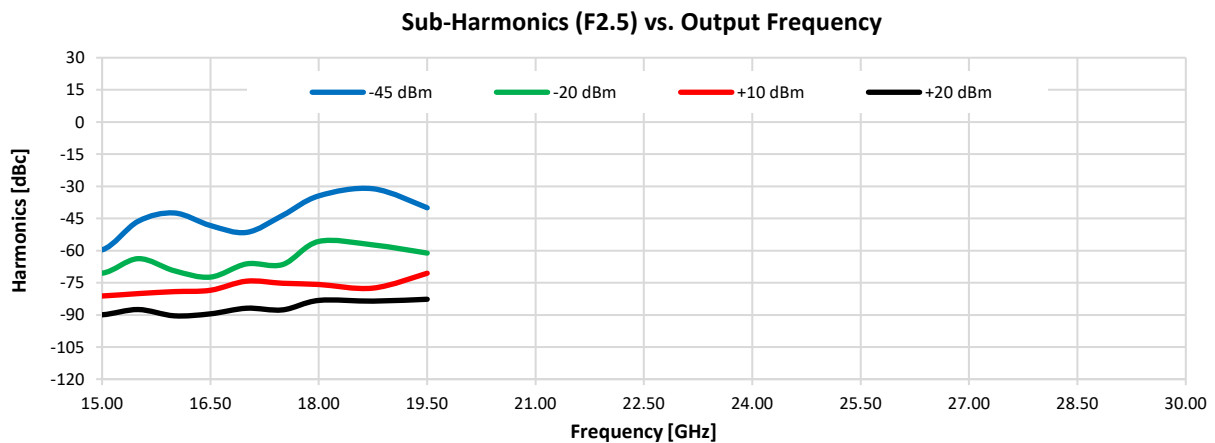
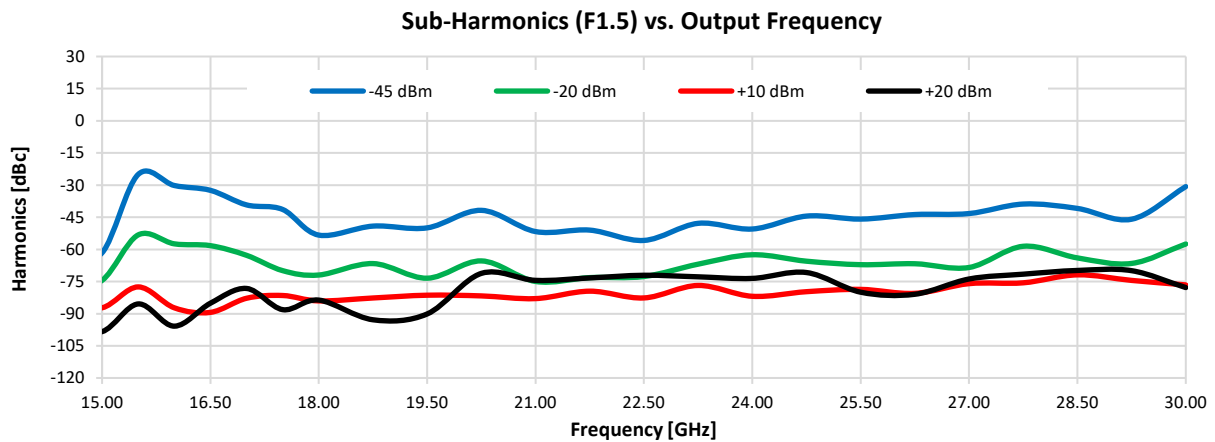
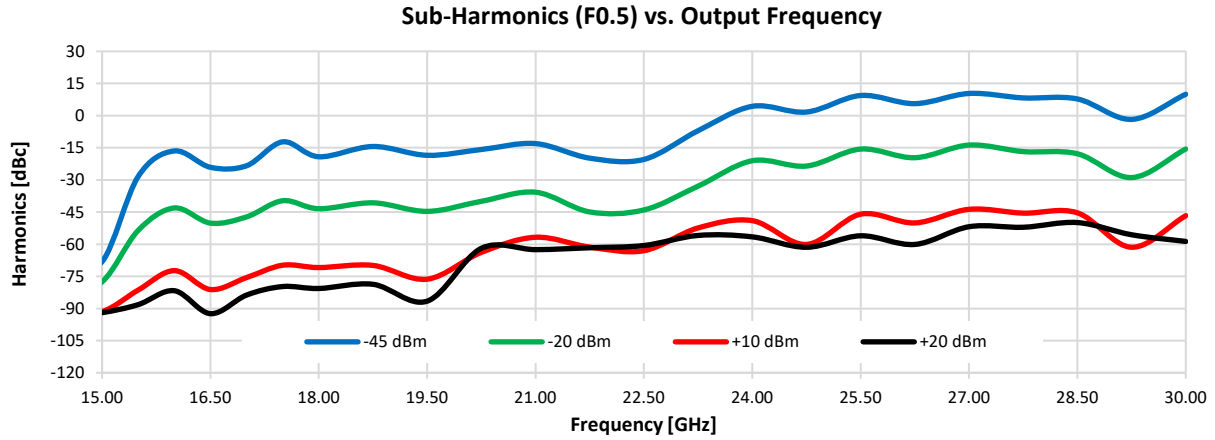

Note: No sub-harmonics below 15 GHz.

Frequency Extender

FX-30GHP-RC

Typical Performance Curves

Test Conditions: @ Temperature = 25°C.

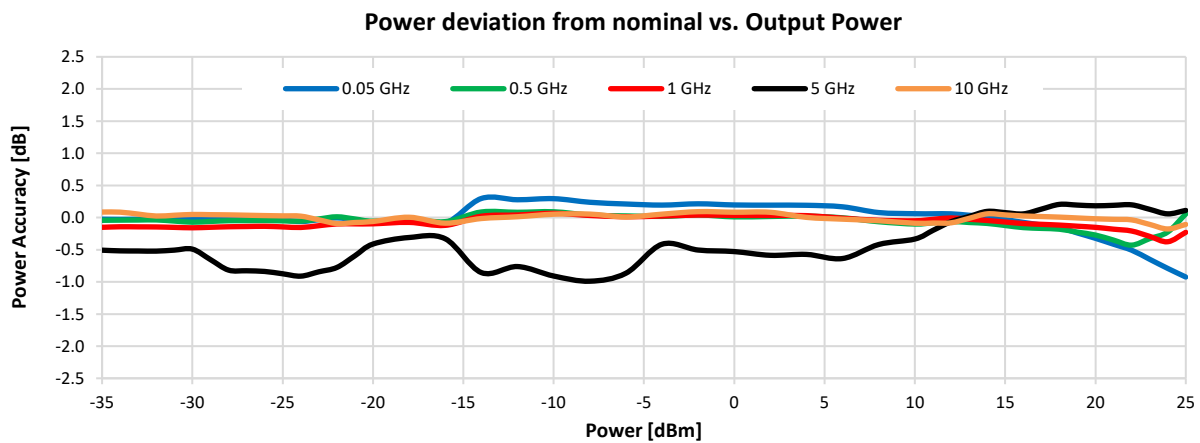
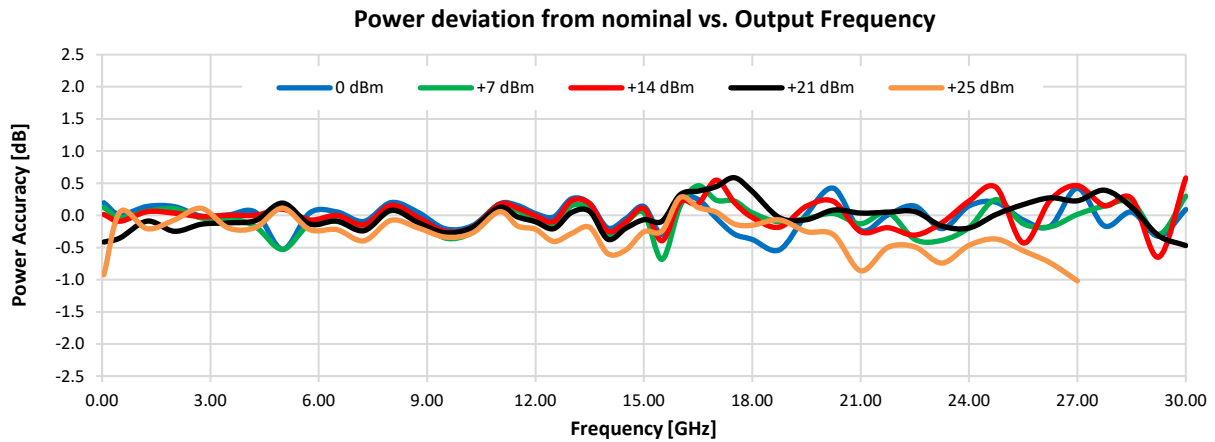
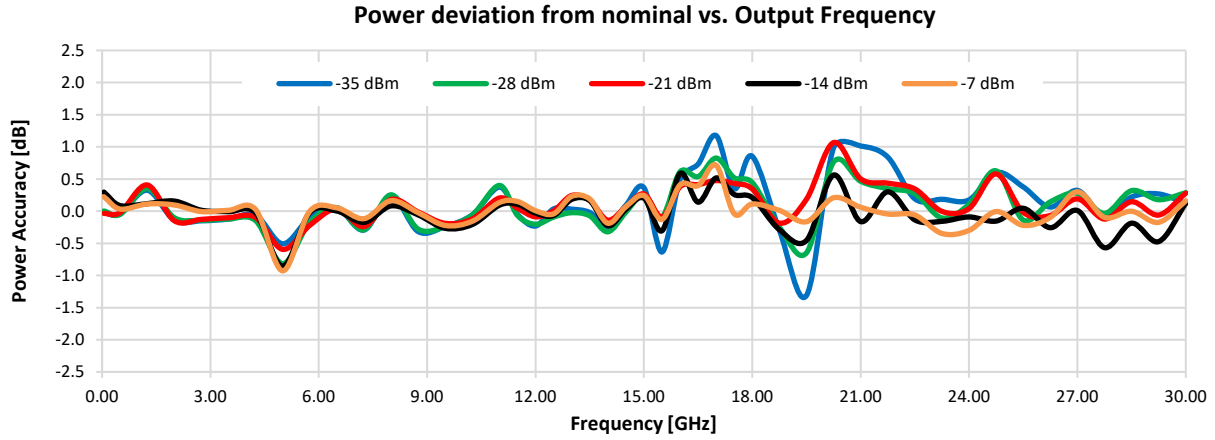

Frequency Extender

FX-30GHP-RC

Typical Performance Curves

Test Conditions: @ Temperature = 25°C.

Power deviation from nominal vs. Output Power

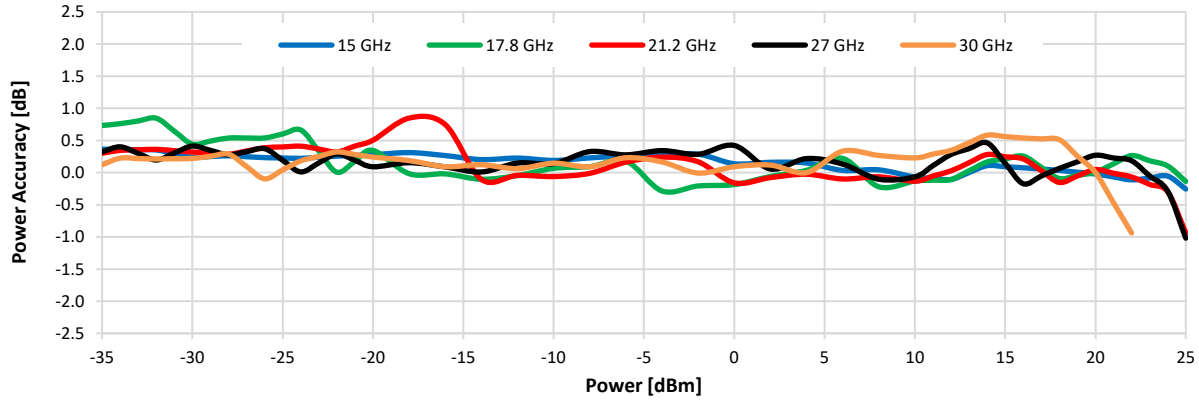

Harmonics (F2) vs. Output Frequency

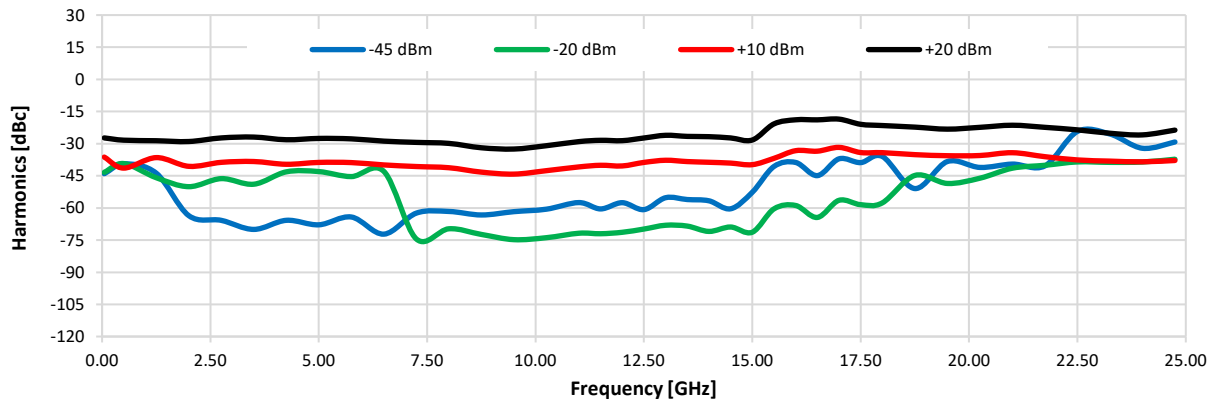

Harmonics (F3) vs. Output Frequency

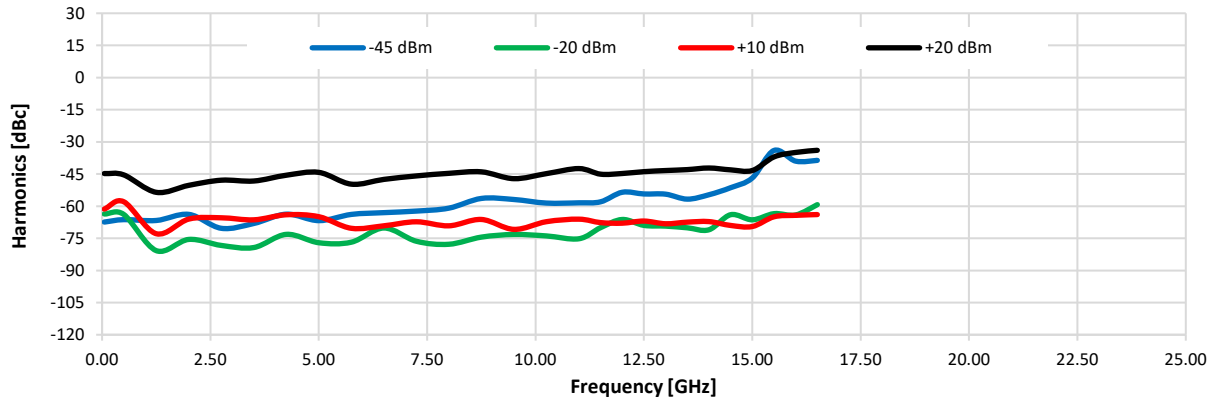

Frequency Extender

FX-30GHP-RC

Typical Performance Curves

Test Conditions: @ Temperature = 25°C.

Sub-Harmonics (F0.5) vs. Output Frequency

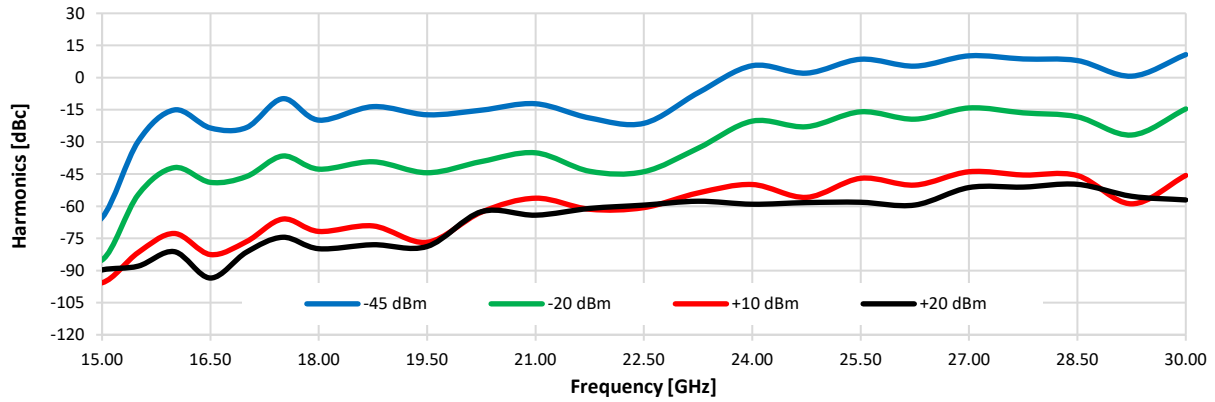

Sub-Harmonics (F1.5) vs. Output Frequency

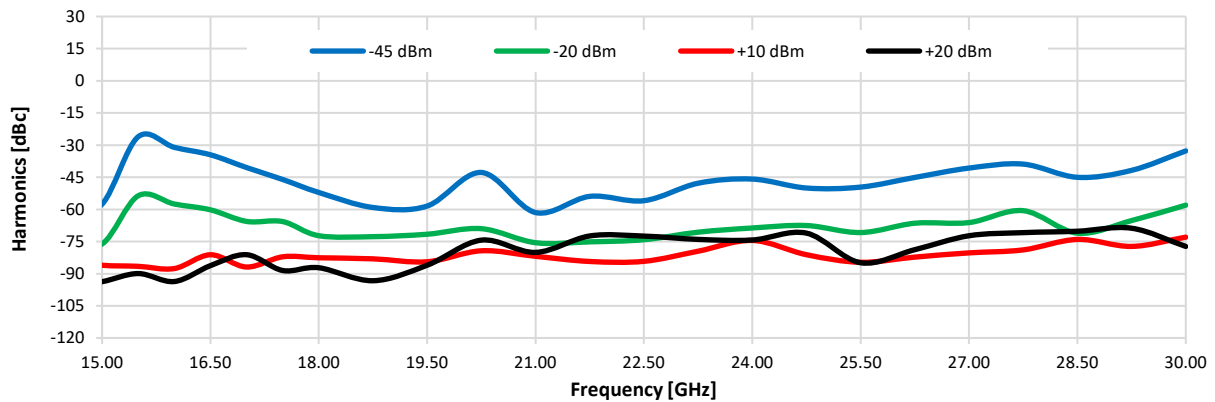

Sub-Harmonics (F2.5) vs. Output Frequency

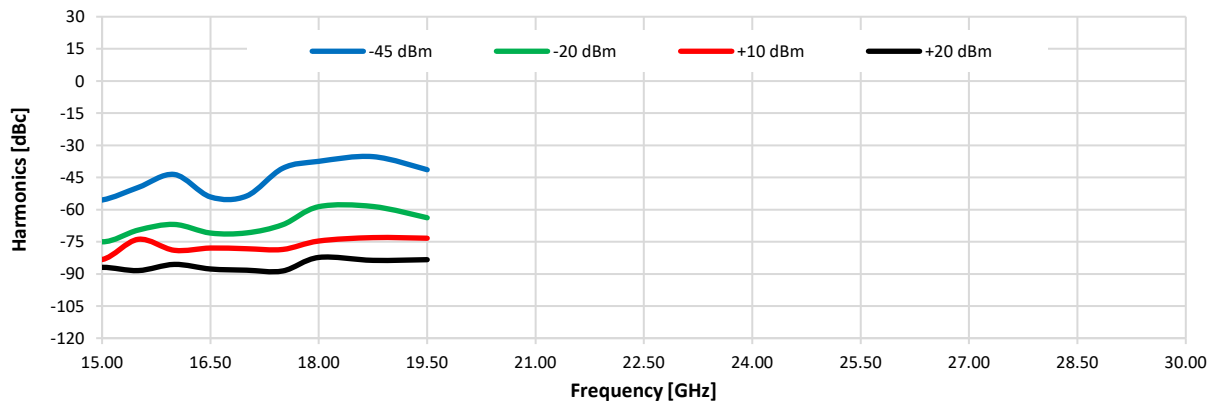

Note: No sub-harmonics below 15 GHz.

Frequency Extender

FX-30GHP-RC

Typical Performance Curves

Test Conditions: @ Temperature = 50°C.

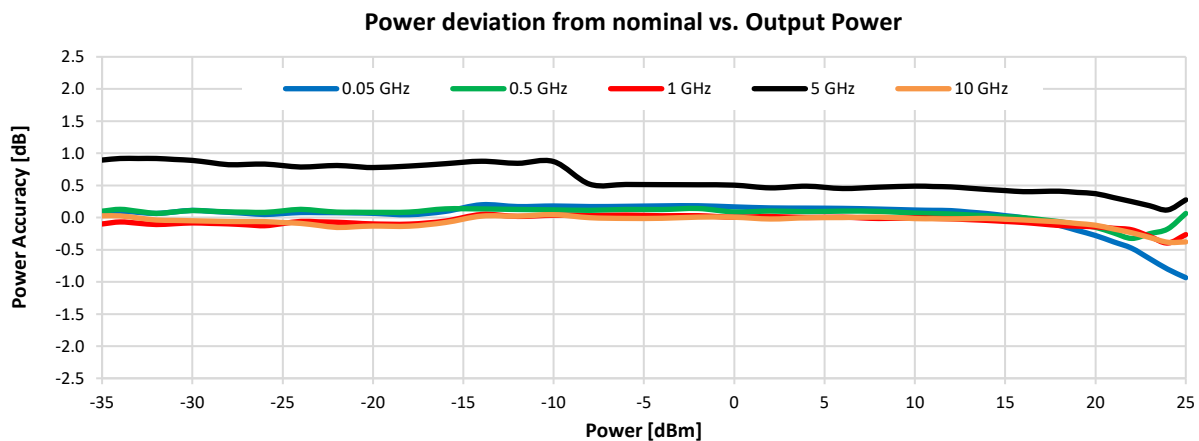
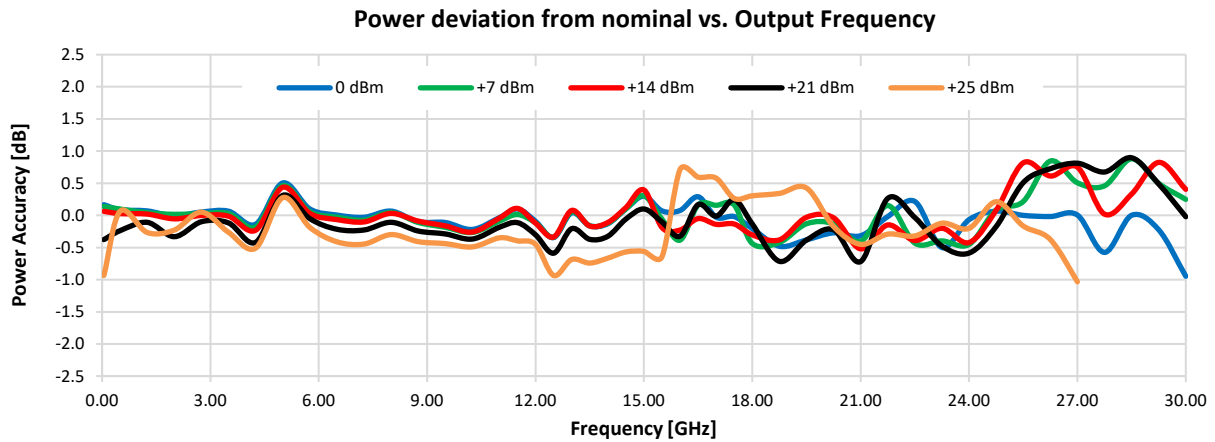
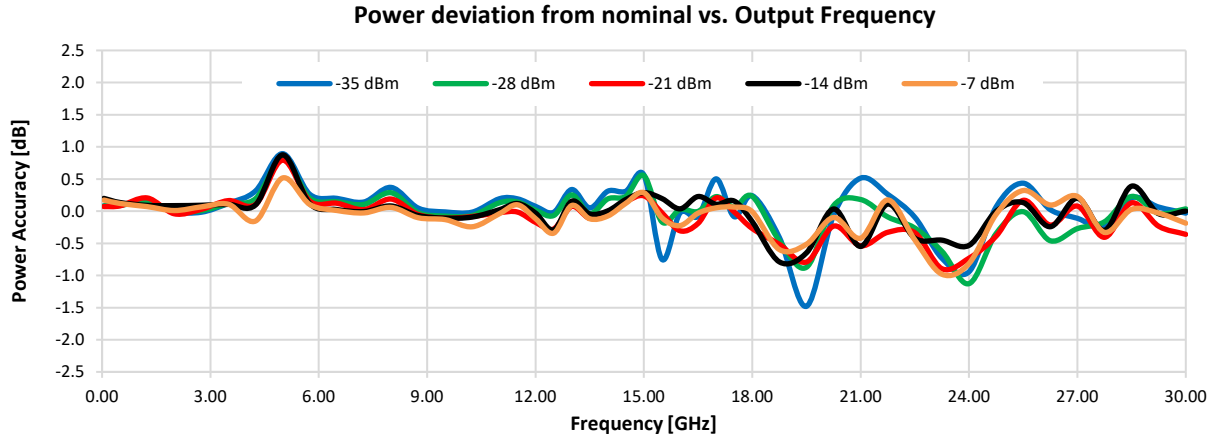

NOTES:

- A. Performance and quality attributes and conditions not expressly stated in this specification document are intended to be excluded and do not form a part of this specification document.
- B. Electrical specifications and performance data contained in this specification document are based on Mini-Circuits' applicable established test performance criteria and measurement instructions.
- C. The parts covered by this specification document are subject to Mini-Circuits standard limited warranty and terms and conditions (collectively, "Standard Terms"); Purchasers of this part are entitled to the rights and benefits contained therein. For a full statement of the Standard Terms and the exclusive rights and remedies thereunder, please visit Mini-Circuits' website at <https://www.minicircuits.com/terms/viewterm.html>



Frequency Extender

FX-30GHP-RC

Typical Performance Curves

Test Conditions: @ Temperature = 50°C.

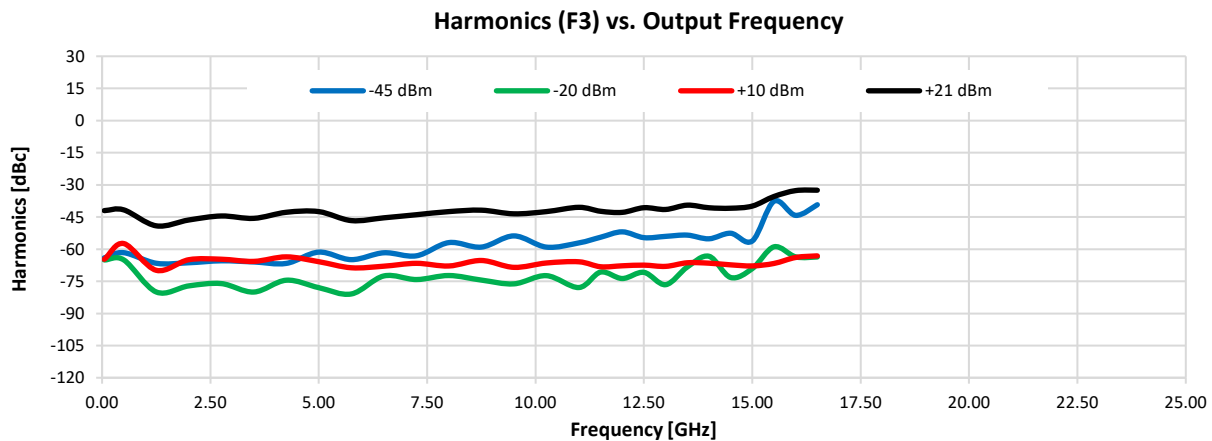
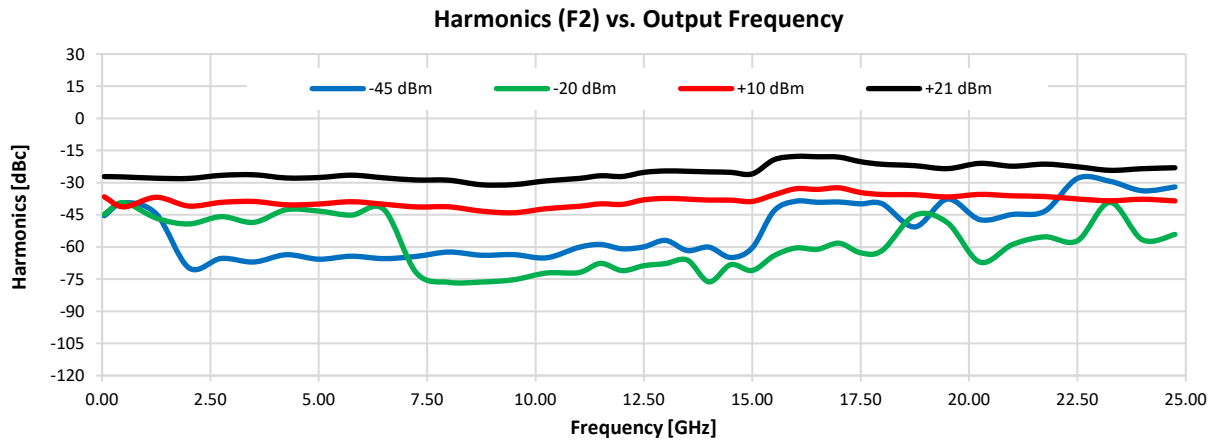
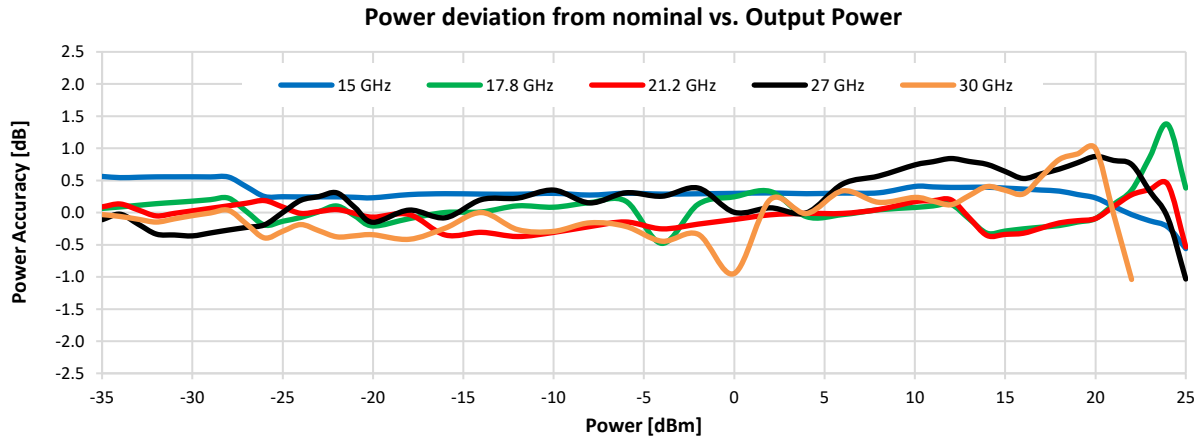

NOTES:

- A. Performance and quality attributes and conditions not expressly stated in this specification document are intended to be excluded and do not form a part of this specification document.
- B. Electrical specifications and performance data contained in this specification document are based on Mini-Circuit's applicable established test performance criteria and measurement instructions.
- C. The parts covered by this specification document are subject to Mini-Circuits standard limited warranty and terms and conditions (collectively, "Standard Terms"); Purchasers of this part are entitled to the rights and benefits contained therein. For a full statement of the Standard Terms and the exclusive rights and remedies thereunder, please visit Mini-Circuits' website at <https://www.minicircuits.com/terms/viewterm.html>



Typical Performance Curves

Test Conditions: @ Temperature = 50°C.

Sub-Harmonics (F0.5) vs. Output Frequency

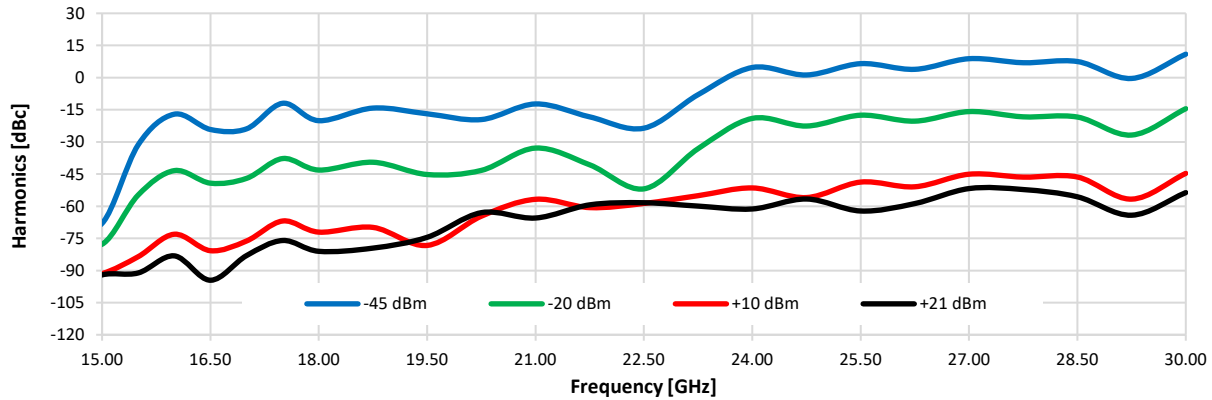

Sub-Harmonics (F1.5) vs. Output Frequency

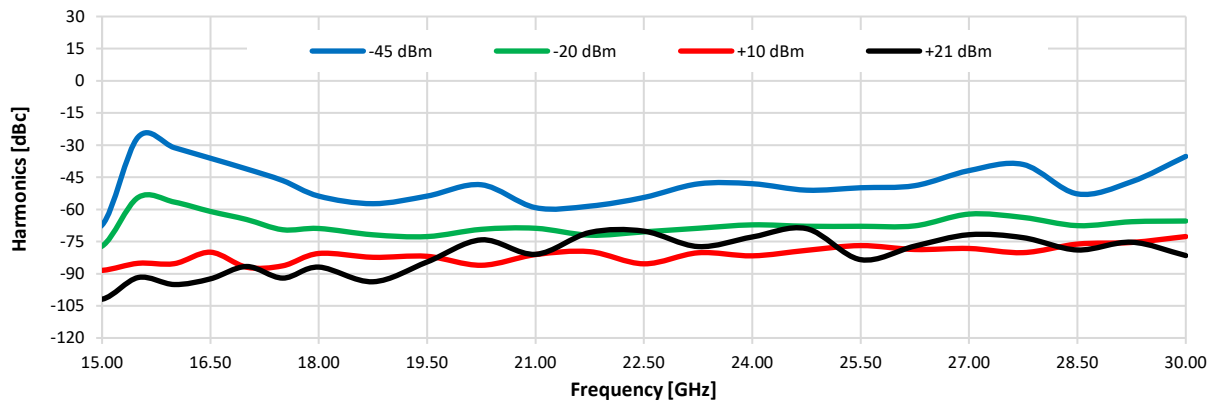

Sub-Harmonics (F2.5) vs. Output Frequency

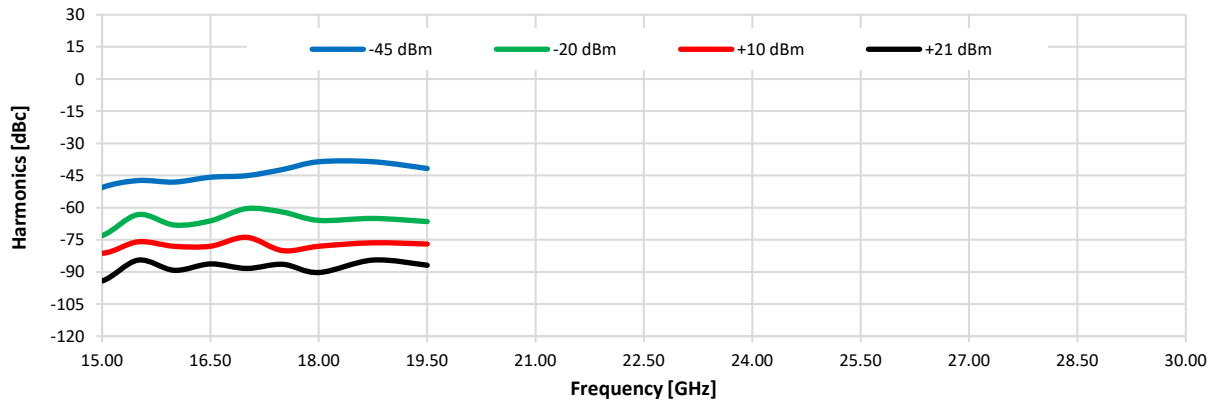

Note: No sub-harmonics below 15 GHz.

NOTES:

- A. Performance and quality attributes and conditions not expressly stated in this specification document are intended to be excluded and do not form a part of this specification document.
- B. Electrical specifications and performance data contained in this specification document are based on Mini-Circuits' applicable established test performance criteria and measurement instructions.
- C. The parts covered by this specification document are subject to Mini-Circuits standard limited warranty and terms and conditions (collectively, "Standard Terms"); Purchasers of this part are entitled to the rights and benefits contained therein. For a full statement of the Standard Terms and the exclusive rights and remedies thereunder, please visit Mini-Circuits' website at <https://www.minicircuits.com/terms/viewterm.html>



Case Style

SL

Outline Dimensions

SL3225

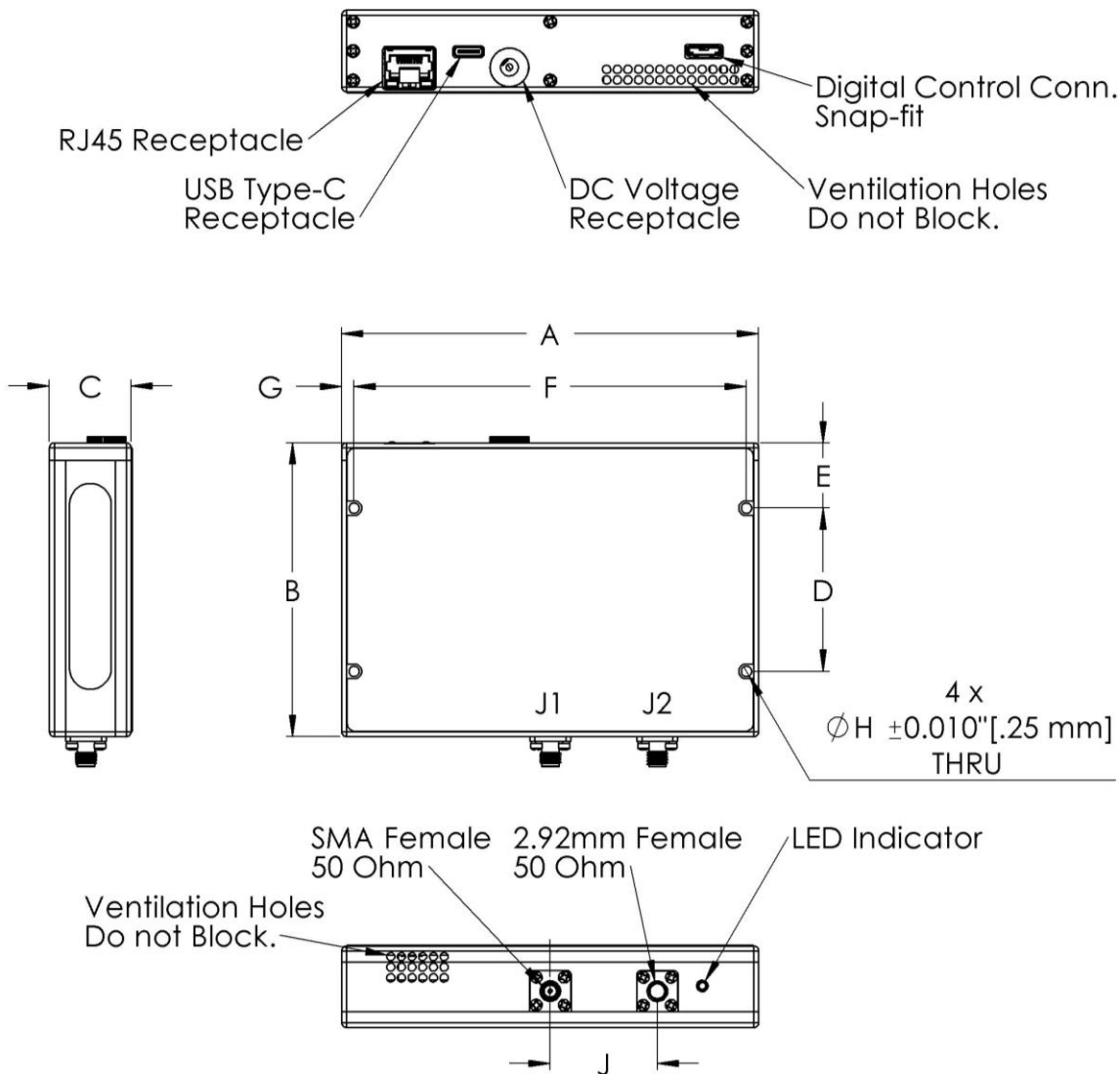

CASE#	A	B	C	D	E	F	G	H	J	Wt. Grams
SL3225	5.10 (129.5)	3.60 (91.4)	1.00 (25.4)	2.000 (50.80)	.800 (20.32)	4.800 (121.92)	.150 (3.81)	.125 (3.18)	1.310 (33.27)	600

Dimensions are in inches (mm). Tolerances: 2PL. +/- .03; 3PL. +/- .015

Notes:

1. Case material: Aluminum alloy.
2. Case finish: Nickel Plate.

Mini-Circuits®

INTERNET <http://www.minicircuits.com>

P.O. Box 350166, Brooklyn, New York 11235-0003 (718) 934-4500 Fax (718) 332-4661

Distribution Centers NORTH AMERICA 800-654-7949 • 417-335-5935 • Fax 417-335-5945 • EUROPE 44-1252-832600 • Fax 44-1252-837010

Mini-Circuits ISO 9001 & ISO 14001 Certified



Environmental Specifications **ENV55**

All Mini-Circuits products are manufactured under exacting quality assurance and control standards, and are capable of meeting published specifications after being subjected to any or all of the following physical and environmental test.

Specification	Test/Inspection Condition	Reference/Spec
Operating Temperature	-0° to 50° C Ambient Environment	Individual Model Data Sheet
Storage Temperature	-20° to 60° C Ambient Environment	Individual Model Data Sheet
Operating and Storage Humidity	5% to 85% RH (non-condensing)	Ambient
Bench Handling Test	Bench Top Tip 45° & Drop	MIL-PRF-28800F
Transit Drop Test	Free Fall Drop, 20 cm (7.9 inches)	MIL-PRF-28800F Class 3