

USB / Ethernet

Integrated Frequency Counter & Power Meter

FCPM-6000RC

50Ω -30 dBm to +20 dBm, 1 MHz to 6000 MHz

The Big Deal

- Automatically synchronized power & frequency measurements
- **USB and Ethernet** control
- Includes GUI with measurement applications software, simplifying complex measurements
- Measurement speed 30ms



CASE STYLE: JL2029

 **Software Package**

Applications

- Production testing systems
- Field testing & remote location monitoring
- automatic, scheduled data collection
- Evaluate high-power, multi-port devices with built-in virtual couplers/attenuators & other software tools.

Included Accessories

Model No.	Description	Qty.
USB-RJ45-CBL-7+	2.6 ft. USB cable	1

RoHS Compliant

See our web site for RoHS Compliance methodologies and qualifications

Product Overview

Mini-Circuits' FCPM-6000RC Integrated Frequency Counter & Power Meter is a compact (5.00 x 2.66 x 1.36") precision test device controlled via USB or Ethernet (HTTP and Telnet protocols) or operated as standalone test instrument. It simplifies test setups by enabling synchronized frequency and power measurements from a single device. The unit features an LCD display allowing convenient readings directly off the measurement head, while our user-friendly GUI software enables easy remote test management via USB or Ethernet.

Full software support is provided, including our user-friendly GUI application for Windows and a full API and programming instructions for both Windows and Linux environments (32-bit and 64-bit systems). The latest version of the full software package can be downloaded from <https://www.minicircuits.com/softwaredownload/fcpm.html> at any time.

Key Features

Feature	Advantages
USB & Ethernet control	USB HID and Ethernet (HTTP / Telnet) interfaces provide easy compatibility with a wide range of software setups and programming environments
'Measurement Application' GUI software built-in	Automated measurement setups which allow the user to perform measurements on RF components such as Couplers, Filters, Amplifiers, etc., display numerical data and graphs, and analyze the data.
LCD character display	LCD character display providing the frequency and power readings, as well as information on the unit's status.
Operates with external or internal reference	The FCPM-6000RC can operate either synchronized with an external 10 MHz reference signal or independently, using its internal reference depending on user preference.
No calibration required before taking measurement	The FCPM-6000RC does not require any reference signal for calibration, reducing test time and simplifying operation.
5V power supply	Powered via USB plug from PC, AC adapter or from commercially available Power Over Ethernet (PoE) splitter with 5V output.

Trademarks: Windows is a registered trademark of Microsoft Corporation in the United States and other countries. Linux is a registered trademark of Linus Torvalds. Mac is a registered trademark of Apple Corporation. Pentium is a registered trademark of Intel Corporation. Neither Mini-Circuits nor the Mini-Circuits FCPM-6000RC are affiliated with or endorsed by the owners of the above referenced trademarks

Mini-Circuits and the Mini-Circuits logo are registered trademarks of Scientific Components Corporation.



www.minicircuits.com P.O. Box 350166, Brooklyn, NY 11235-0003 (718) 934-4500 sales@minicircuits.com

Rev. E
ECO-019961
EDR-11250
FCPM-6000RC
MCIL
231115
Page 1 of 8

Electrical Specifications (CW)¹, -30 dBm to +20 dBm, 1 to 6000 MHz

Parameter		Freq. Range (MHz)	Min.	Typ.	Max.	Units
Dynamic range ^{2,3,4}	@ 25°C	1 - 5700	-30	-	+20	dBm
		5700 - 6000	-28	-	+20	
	@ 0°C to 50°C	1 - 6000	-27	-	+20	
VSWR		1 - 6000	-	1.05	1.25	:1
Uncertainty of Power Measurement @ 25°C	@ -30 to +5 dBm ^{5,6}	1 - 3000	-	± 0.10	± 0.30	dB
		3000 - 6000	-	± 0.15	± 0.30	dB
	@ +5 to +15 dBm	1 - 3000	-	± 0.15	± 0.30	dB
		3000 - 6000	-	± 0.15	± 0.30	dB
	@ +15 to +20 dBm	1 - 3000	-	± 0.20	± 0.40	dB
		3000 - 6000	-	± 0.20	± 0.40	dB
Uncertainty of Power Measurement @ 0°C to 50°C	@ -30 to +5 dBm ^{5,6}	1 - 3000	-	± 0.25	-	dB
		3000 - 6000	-	± 0.25	-	dB
	@ +5 to +15 dBm	1 - 3000	-	± 0.20	-	dB
		3000 - 6000	-	± 0.20	-	dB
	@ +15 to +20 dBm	1 - 3000	-	± 0.35	-	dB
		3000 - 6000	-	± 0.30	-	dB
Power Linearity @ 25°C		1 - 6000	-	± 3.0	-	%
Power Resolution		1 - 6000	0.01	-	-	dB
Frequency Resolution		1 - 40 MHz	-	1	-	Hz
		40-190 MHz	-	10	-	
		190-6000 MHz	-	100	-	
Frequency Uncertainty (@ 1 sec measurement sample time) ^{4,7}		1 - 40 MHz	-	±2	-	Hz
		40-190 MHz	-	±20	-	
		190-1400 MHz	-	±200	-	
		1400 - 6000 MHz	-	±800	-	
Averaging Range		1 - 6000	1	-	999	-
Frequency Aging	Using int. Reference	-	-	-	±1.0	ppm/year
Measurement Speed (for power meas.)	@ Low Noise Mode	1 - 6000	-	100	-	msec
	@ Faster Mode		-	30	-	
Sample time (for frequency meas.) ⁸		-	100	1000	3000	msec
Input Impedance		-	-	50	-	Ω
Reference In Frequency		-	-	10	-	MHz
Reference In Impedance		-	-	50	-	Ω
Reference In Power		-	-5	-	+10	dBm
Supply Voltage	via USB port	1 - 6000	4.5	5	5.5	V
Current (via USB port, in USB control)		1 - 6000	-	370	500	mA
Current (via USB port, in Ethernet control)		1 - 6000	-	380	500	mA
Ethernet communication		Supports both Telnet and HTTP protocols over TCP/IP with dynamic(DHCP) or static IP				

¹ All specifications apply to continuous wave (CW) signals.

² Maximum continuous safe operational power limit: +23 dBm. Performance is guaranteed up to +20 dBm.

³ The FCPM-6000RC can operate down to -32 dBm, however performance is guaranteed only in the range specified in the table.

⁴ Minimum power for Frequency measurement at 190-240 MHz may degrade by up to 3 dB due to measurement band switching.

⁵ When using Faster mode at high frequencies below -20dBm, use of averaging is recommended to prevent noise errors.

⁶ When using Faster mode power reading below -20dBm, uncertainty value may increase by up to 0.2 dB relative to Low noise mode power reading.

⁷ Accuracy shown using external 10 MHz reference synchronized to test signal. Using Internal Reference adds 2 ppm of tested frequency to the accuracy values shown.

⁸ Software function set by user, default option 1000 mec.

Absolute Maximum Ratings

Parameter	Ratings
Operating Temperature	0°C to 50°C
Storage Temperature	-30°C to 70°C
V _{USB} Max.	6 V
DC Voltage @ RF port	15 V
RF Power(CW) @ RF port	+25 dBm
DC Voltage @ Reference Input	25 V
RF Power(CW) @ Reference Input	+13 dBm

Permanent damage may occur if any of these limits are exceeded. Operating in the range between operating power limits and absolute maximum ratings for extended periods of time may result in reduced life and reliability.

Connections

Reference Input	(BNC-Female)
Signal Input	(N-Typ-Male)
Power & Control	(Push-Pull connector)

Typical Performance Curves

VSWR

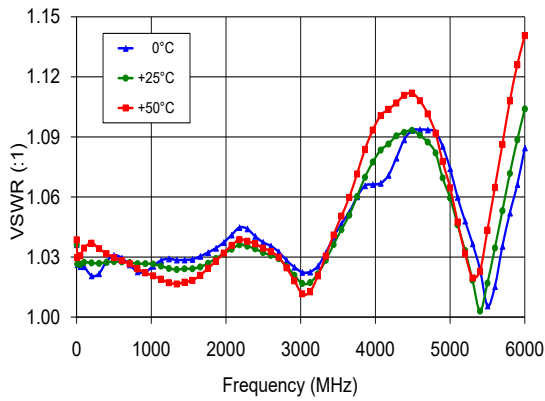

Uncertainty of Power Measurement @ +25°C

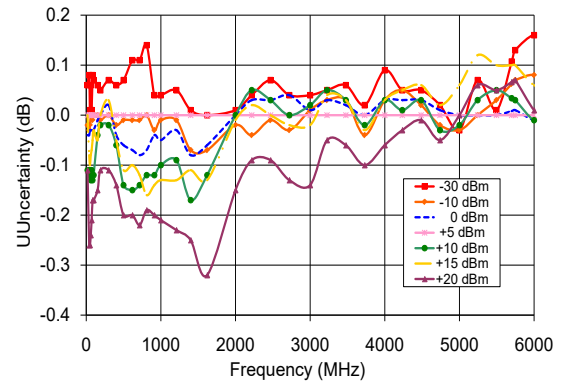

Linearity @ +25°C

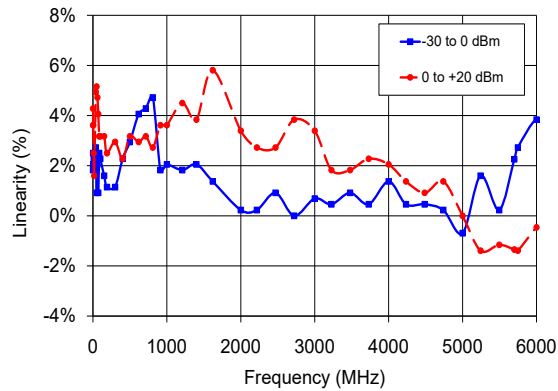

Typ. Input Power Threshold for Frequency Measurement @ +25°C

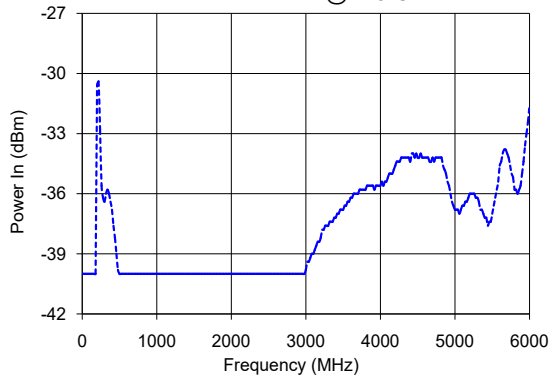

Uncertainty of Frequency Measurement @ +25°C

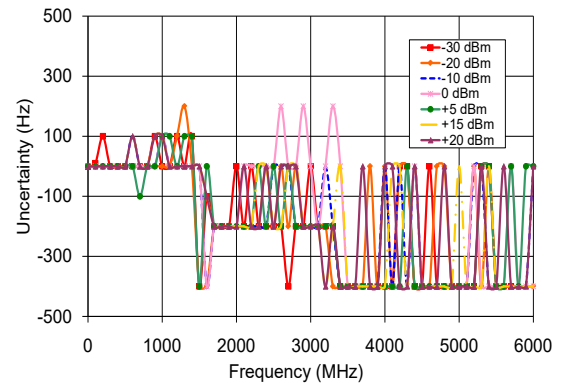

Outline Drawing (JL2029)

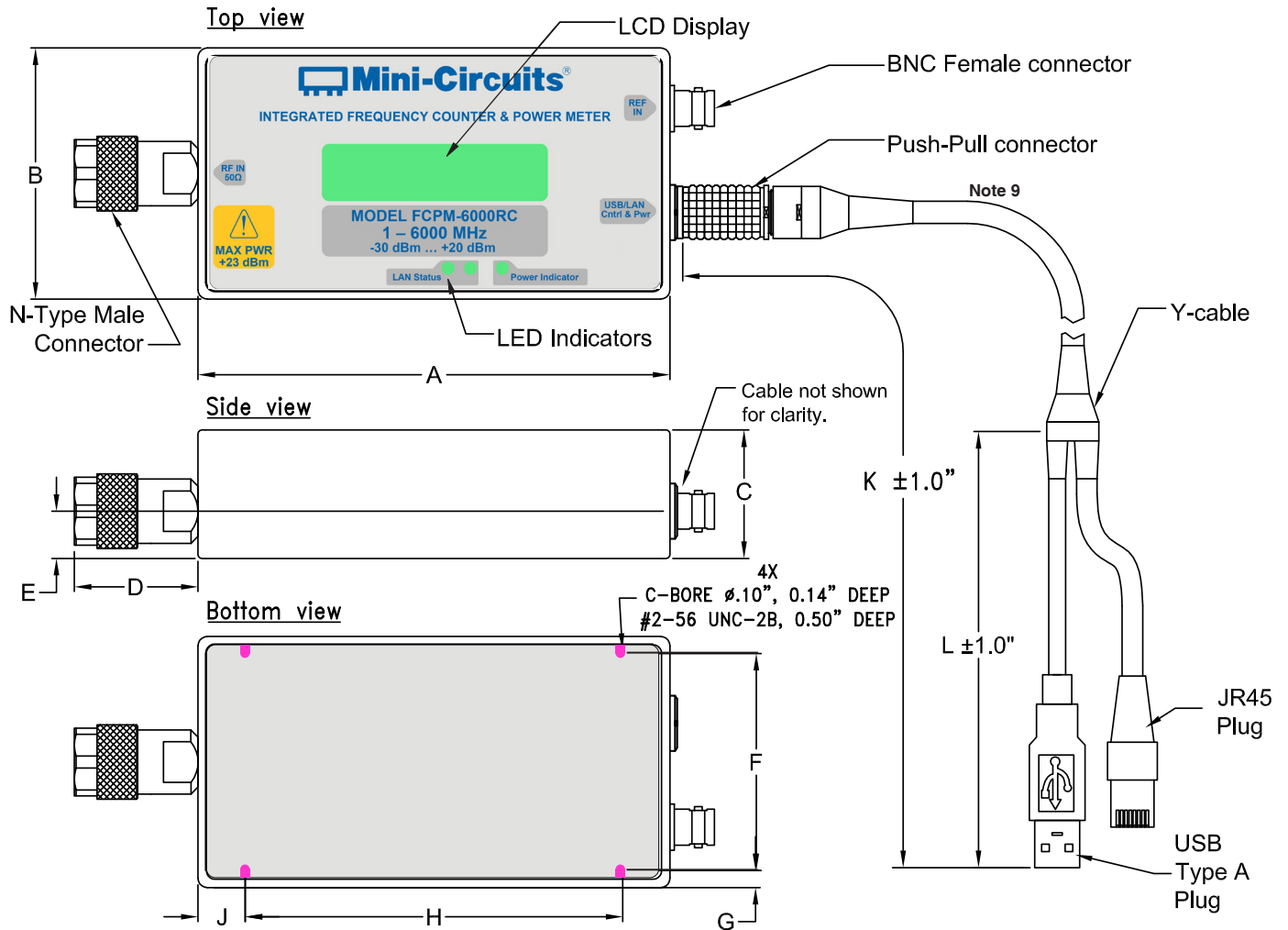

Outline Dimensions (inch mm)

A	B	C	D	E	F	G	H	J	K	L	WT. GRAMS
5.00 (127.0)	2.66 (67.6)	1.36 (34.5)	1.31 (33.3)	0.50 (12.7)	2.300 (58.42)	0.18 (4.6)	4.000 (101.60)	0.50 (12.7)	81 (2057)	20 (508)	500

⁹ FCPM-6000RC to be used with the supplied control cable only.

Connection diagrams

Connection diagram for USB control

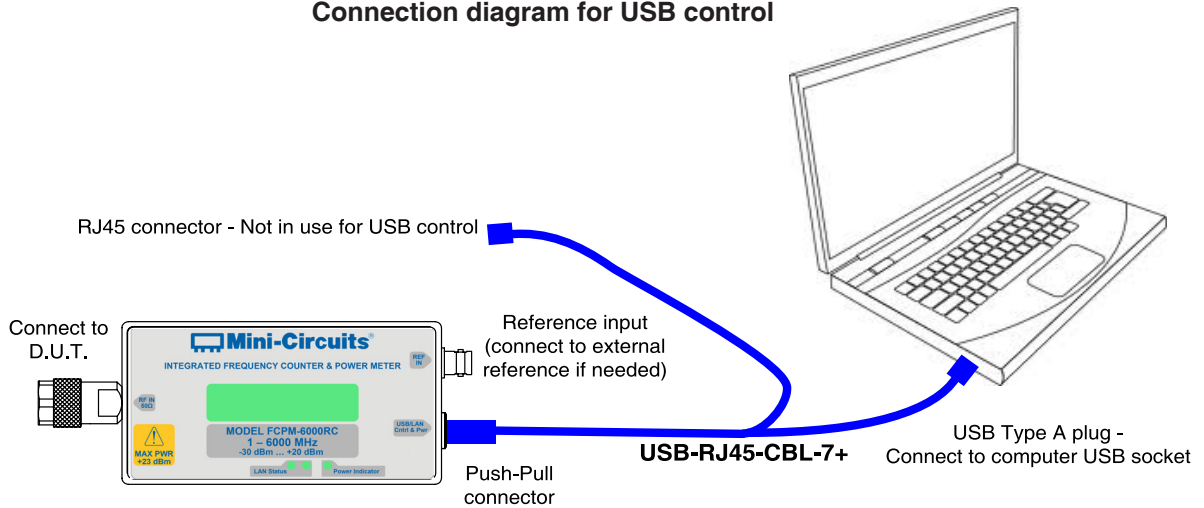

Connection diagram for Ethernet control, using power adaptor

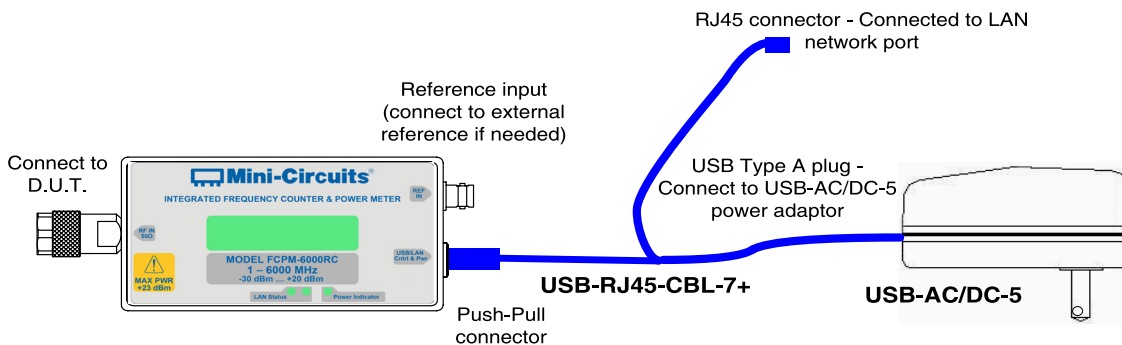

Connection diagram for Ethernet control, using PoE system

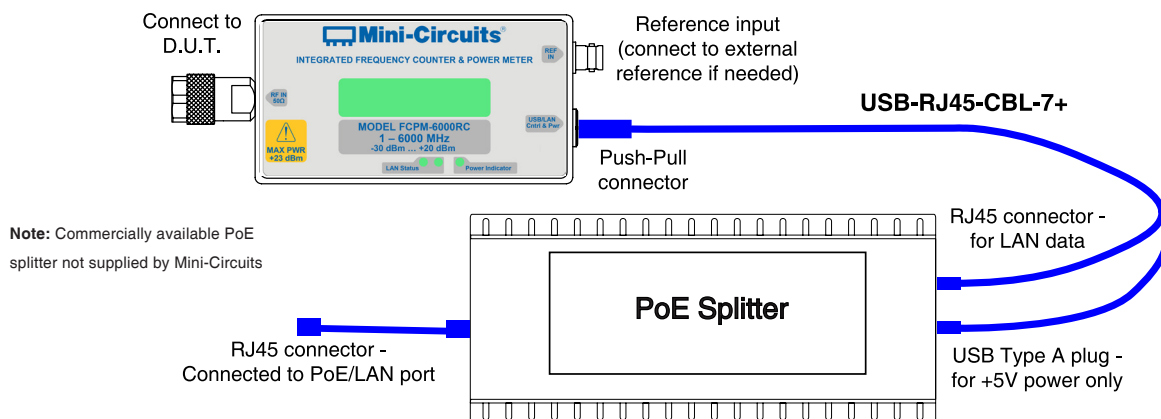

Note: Commercially available PoE splitter not supplied by Mini-Circuits



Software & Documentation Download:

- Mini-Circuits' full software and support package including user guide, Windows GUI, DLL files, programming manual and examples can be downloaded free of charge from <https://www.minicircuits.com/softwaredownload/fcpm.html>.
- Please contact testsolutions@minicircuits.com for support

Minimum System Requirements

Parameter	Requirements	
Interface	USB HID or HTTP Get/Post or Telnet protocols	
System requirements	GUI:	Windows 32 & 64 bit systems from Windows 98 up to Windows 10
	USB API (ActiveX & .Net)	Windows 32 & 64 bit systems with ActiveX or .Net support from Windows 98 up to Windows 10
	USB direct programming support	Linux, Windows systems from Windows 98 up to Windows 10
	HTTP or Telnet	Any computer with a network port and Ethernet-TCP/IP (HTTP or Telnet protocols) support
Hardware	Pentium® II or higher, RAM 256 MB	
Y control cable for USB and Ethernet (supplied)	Model to be used with the supplied control cable only	

Graphical User Interface (GUI) for Windows

Key Features:

- Automatically synchronized power and frequency measurements.
- Relative and Average power measurements
- Setting measurement speed for power and frequency independently.
- Freq. & Power measurement data recording
- Measurement application tools
- online graphical display of power measurement
- USB, HTTP or Telnet control of FCPM
- Setting Ethernet configuration

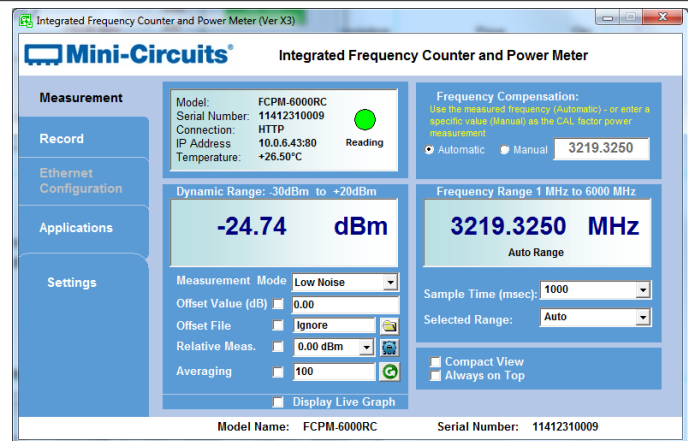

Application Programming Interface (API)

Windows Support:

- API DLL files exposing the full power sensor functionality
 - ActiveX COM DLL file for creation of 32-bit programs
 - .Net library DLL file for creation of 32 / 64-bit programs
- HTTP Get/Post and Telnet protocols use SCPI commands to provide full control.
- Supported by most common programming environments (refer to application note [AN-49-001](#) for summary of tested environments)

Linux Support:

- Full power sensor control in a Linux environment is achieved by way of USB interrupt commands.

Ordering Information

Model	Description
FCPM-6000RC	Integrated Frequency Counter & Power Meter

Included Accessories	Part No.	Description
	USB-RJ45-CBL-7+	6.6 ft (2 m) "Y" data cable with USB Type-A and RJ45 plug connectors ⁹

⁹ FCPM-6000RC to be used with the supplied control cable only.

Optional Accessories	Description
USB-AC/DC-5	AC/DC 5V _{DC} Power Adapter with US, EU, IL, UK, AUS, and China power plugs ^{10,11}
USB-RJ45-CBL-7+ (spare)	6.6 ft (2 m) "Y" data cable with USB Type-A and RJ45 plug connectors
NF-SM50+	N-Type Female to SMA Male Adapter (For mating with SMA devices).
NF-SF50+	N-Type Female to SMA Female Adapter
NF-BM50+	N-Type Female to BNC Male Adapter.

¹⁰ Power plugs for other countries are also available, if you need a power plug for a country not listed in the table please contact testsolutions@minicircuits.com for support.

¹¹ The USB-AC/DC-5 may be used to provide the 5V_{DC} power input via USB port if operating with Ethernet control. Not required if using USB control.

Calibration	Description
CAL-FCPM-6000RC	Calibration Service Click Here

Additional Notes

- A. Performance and quality attributes and conditions not expressly stated in this specification document are intended to be excluded and do not form a part of this specification document.
- B. Electrical specifications and performance data contained in this specification document are based on Mini-Circuit's applicable established test performance criteria and measurement instructions.
- C. The parts covered by this specification document are subject to Mini-Circuits standard limited warranty and terms and conditions (collectively, "Standard Terms"); Purchasers of this part are entitled to the rights and benefits contained therein. For a full statement of the Standard Terms and the exclusive rights and remedies thereunder, please visit Mini-Circuits' website at www.minicircuits.com/MCLStore/terms.jsp

Integrated Freq. & Power Meter

FCPM-6000RC

Typical Performance Data

FREQ. (MHz)	VSWR (:1)		
	0°C	+25°C	+50°C
1	1.04	1.04	1.04
10	1.03	1.03	1.03
20	1.03	1.03	1.03
50	1.03	1.03	1.03
100	1.03	1.03	1.03
200	1.02	1.03	1.04
400	1.03	1.03	1.03
600	1.03	1.03	1.03
800	1.02	1.03	1.02
1000	1.02	1.03	1.02
1200	1.03	1.02	1.02
1400	1.03	1.02	1.02
1600	1.03	1.03	1.02
1800	1.03	1.03	1.03
2000	1.04	1.03	1.03
2200	1.04	1.03	1.04
2400	1.04	1.03	1.04
2600	1.04	1.03	1.03
2800	1.03	1.03	1.02
3000	1.02	1.02	1.01
3200	1.02	1.02	1.02
3400	1.03	1.03	1.03
3600	1.05	1.05	1.06
3800	1.06	1.07	1.08
4000	1.07	1.08	1.10
4200	1.07	1.09	1.11
4400	1.09	1.09	1.11
4600	1.09	1.09	1.11
4800	1.09	1.08	1.09
5000	1.07	1.06	1.06
5200	1.05	1.03	1.03
5400	1.02	1.00	1.02
5600	1.02	1.03	1.06
5800	1.05	1.07	1.11
6000	1.08	1.10	1.14
6200	1.12	1.13	1.16
6400	1.16	1.16	1.17
6600	1.18	1.18	1.18
6800	1.20	1.21	1.22
7000	1.25	1.27	1.29
7500	1.34	1.34	1.35
8000	1.44	1.41	1.34

LINEARITY @ -30 to 0 dBm	
FREQ (MHz)	- (%)
1	1.83
2	2.50
5	2.05
10	2.28
50	0.92
100	2.28
300	1.14
500	2.95
1000	2.05
1400	2.05
2000	0.23
3000	0.69
4000	1.37
5000	-0.69
6000	3.84
6500	-0.23

LINEARITY @ 0 to +20 dBm	
FREQ (MHz)	- (%)
1	4.28
2	3.62
5	3.62
10	2.50
50	5.16
100	3.17
300	2.95
500	3.17
1000	3.62
1400	3.84
2000	3.39
3000	3.39
4000	2.05
5000	0.00
6000	-0.46
6500	-0.23

Notes

- A. Performance and quality attributes and conditions not expressly stated in this specification document are intended to be excluded and do not form a part of this specification document.
- B. Electrical specifications and performance data contained in this specification document are based on Mini-Circuits' applicable established test performance criteria and measurement instructions.
- C. The parts covered by this specification document are subject to Mini-Circuits' standard limited warranty and terms and conditions (collectively, "Standard Terms"); Purchasers of this part are entitled to the rights and benefits contained therein. For a full statement of the Standard Terms and the exclusive rights and remedies thereunder, please visit Mini-Circuits' website at www.minicircuits.com/MCLStore/terms.jsp



Typical Performance Data

FREQ. (MHz)	UNCERTAINTY OF POWER MEASUREMENT @ 25°C (dBm)						
	-30 dBm	-10 dBm	0 dBm	+5 dBm	+10 dBm	+15 dBm	+20 dBm
1	-0.02	-0.07	-0.09	-0.16	-0.18	-0.10	-0.27
2	0.00	-0.06	-0.11	-0.14	-0.16	-0.11	-0.26
5	0.00	-0.05	-0.09	-0.15	-0.17	-0.08	-0.25
10	0.02	-0.03	-0.08	-0.13	-0.15	-0.06	-0.19
17	0.06	-0.02	-0.04	-0.09	-0.11	0.00	-0.11
40	0.08	-0.03	-0.04	-0.04	-0.11	-0.08	-0.26
50	0.01	-0.02	-0.03	-0.05	-0.12	-0.10	-0.26
61	0.06	0.00	-0.03	-0.05	-0.13	-0.08	-0.24
73	0.01	0.00	-0.03	-0.04	-0.11	-0.07	-0.21
85	0.08	-0.01	-0.03	-0.06	-0.13	-0.05	-0.17
100	0.07	0.00	-0.03	-0.04	-0.12	-0.03	-0.17
152	0.06	0.00	-0.01	0.00	-0.04	-0.05	-0.15
190	0.05	-0.01	0.00	-0.01	-0.02	0.00	-0.11
300	0.07	0.00	0.02	0.03	-0.02	0.03	-0.11
403	0.06	-0.02	-0.04	-0.04	-0.06	-0.05	-0.14
500	0.07	-0.01	-0.06	-0.10	-0.14	-0.11	-0.20
619	0.11	-0.01	-0.07	-0.09	-0.15	-0.10	-0.20
716	0.11	-0.01	-0.08	-0.10	-0.14	-0.12	-0.22
810	0.14	0.00	-0.07	-0.09	-0.12	-0.16	-0.19
913	0.04	-0.03	-0.04	-0.08	-0.12	-0.14	-0.20
1000	0.04	-0.01	-0.05	-0.07	-0.10	-0.13	-0.21
1209	0.05	-0.01	-0.03	-0.05	-0.09	-0.13	-0.23
1400	0.01	-0.07	-0.08	-0.08	-0.17	-0.11	-0.25
1621	0.00	-0.07	-0.06	-0.08	-0.12	-0.13	-0.32
2000	0.01	-0.02	0.00	0.01	0.00	-0.01	-0.15
2217	0.04	-0.04	0.03	0.04	0.05	0.02	-0.09
2470	0.07	-0.01	0.03	0.02	0.03	0.00	-0.09
2722	0.04	-0.03	0.04	0.01	0.00	-0.02	-0.13
3000	0.04	0.01	0.01	0.02	0.02	-0.02	-0.14
3226	0.05	0.03	0.03	0.04	0.05	0.04	-0.05
3478	0.06	0.03	0.02	0.01	0.03	0.03	-0.06
3730	0.02	-0.04	0.00	-0.03	-0.02	-0.03	-0.10
4000	0.09	0.03	0.03	0.01	0.03	0.03	-0.06
4235	0.05	0.05	0.03	0.01	0.01	0.05	-0.03
4487	0.05	0.02	0.03	0.05	0.03	0.06	-0.01
4739	0.02	-0.02	0.01	-0.01	-0.03	0.02	-0.05
5000	-0.03	-0.03	0.00	-0.04	-0.02	0.06	0.00
5243	0.07	0.00	0.00	0.02	0.03	0.12	0.06
5496	0.01	0.03	0.00	0.04	0.05	0.10	0.05
5700	0.11	0.06	0.01	0.01	0.03	0.10	0.07
5748	0.13	0.07	0.01	0.00	0.03	0.10	0.07
6000	0.16	0.08	-0.01	0.01	-0.01	0.06	0.01
6110	0.13	0.05	0.00	0.00	0.01	0.07	0.01
6345	0.01	0.01	-0.01	0.00	-0.02	0.08	0.04
6500	-0.04	0.00	-0.03	-0.05	-0.04	0.00	-0.02

Notes

- A. Performance and quality attributes and conditions not expressly stated in this specification document are intended to be excluded and do not form a part of this specification document.
- B. Electrical specifications and performance data contained in this specification document are based on Mini-Circuits' applicable established test performance criteria and measurement instructions.
- C. The parts covered by this specification document are subject to Mini-Circuits' standard limited warranty and terms and conditions (collectively, "Standard Terms"); Purchasers of this part are entitled to the rights and benefits contained therein. For a full statement of the Standard Terms and the exclusive rights and remedies thereunder, please visit Mini-Circuits' website at www.minicircuits.com/MCLStore/terms.jsp



Integrated Freq. & Power Meter

FCPM-6000RC

Typical Performance Data

FREQ. (MHz)	UNCERTAINTY OF FREQUENCY MEASUREMENT @ 25°C (Hz)						
	-30 dBm	-10 dBm	0 dBm	+5 dBm	+10 dBm	+15 dBm	+20 dBm
1	-1.00	0.00	0.00	0.00	-1.00	0.00	0.00
2	0.00	0.00	0.00	0.00	0.00	0.00	0.00
5	0.00	1.00	0.00	0.00	1.00	1.00	1.00
10	-4.00	-4.00	-4.00	-4.00	-4.00	-4.00	4.00
20	0.00	0.00	0.00	0.00	0.00	0.00	0.00
40	0.00	0.00	0.00	0.00	0.00	0.00	0.00
60	10.00	0.00	0.00	0.00	0.00	0.00	0.00
80	0.00	0.00	10.00	0.00	0.00	0.00	0.00
100	0.00	0.00	0.00	0.00	0.00	0.00	0.00
120	10.00	0.00	0.00	10.00	0.00	10.00	0.00
140	-20.00	-20.00	-20.00	-20.00	-20.00	-20.00	0.00
160	40.00	-10.00	-10.00	-10.00	-10.00	-10.00	0.00
190	200.00	0.00	0.00	0.00	0.00	0.00	0.00
300	0.00	-100.00	0.00	0.00	0.00	0.00	0.00
400	0.00	0.00	0.00	0.00	0.00	0.00	0.00
500	0.00	0.00	100.00	0.00	0.00	0.00	0.00
600	0.00	0.00	0.00	0.00	0.00	100.00	0.00
700	0.00	0.00	0.00	0.00	0.00	0.00	0.00
800	0.00	0.00	0.00	0.00	0.00	0.00	0.00
900	0.00	0.00	0.00	0.00	0.00	0.00	0.00
1000	100.00	100.00	100.00	100.00	100.00	0.00	100.00
1200	0.00	100.00	0.00	100.00	0.00	0.00	0.00
1400	0.00	0.00	-100.00	0.00	-100.00	0.00	-100.00
1600	0.00	0.00	0.00	0.00	0.00	0.00	0.00
2000	-200.00	-200.00	-200.00	-200.00	-200.00	-200.00	-200.00
2220	-200.00	-200.00	-200.00	-200.00	-200.00	-200.00	-200.00
2460	-200.00	0.00	0.00	0.00	-200.00	-200.00	-200.00
2720	-200.00	0.00	0.00	0.00	-200.00	0.00	-200.00
3000	-200.00	-200.00	200.00	-200.00	-200.00	200.00	-200.00
3220	-200.00	-200.00	-200.00	-1000.00	-200.00	0.00	0.00
3480	-400.00	0.00	-400.00	0.00	-400.00	-400.00	-400.00
3740	-400.00	0.00	0.00	0.00	-400.00	0.00	-400.00
4000	-400.00	-400.00	-400.00	-400.00	-400.00	-400.00	-400.00
4240	-400.00	0.00	-400.00	0.00	-400.00	0.00	0.00
4480	0.00	-400.00	-400.00	-400.00	-400.00	-400.00	-400.00
4740	-400.00	-400.00	-400.00	-400.00	-400.00	-400.00	-400.00
5000	-400.00	-400.00	-400.00	-400.00	-400.00	-400.00	0.00
5240	400.00	-400.00	-400.00	-400.00	-400.00	-400.00	-400.00
5500	-400.00	-400.00	-400.00	-400.00	-400.00	-400.00	-400.00
5700	400.00	-400.00	400.00	400.00	-400.00	-400.00	-400.00
5740	0.00	-400.00	-400.00	-400.00	-400.00	-400.00	0.00
6000	0.00	-1.00	-1.00	0.00	-1.00	-1.00	0.00

Notes

- A. Performance and quality attributes and conditions not expressly stated in this specification document are intended to be excluded and do not form a part of this specification document.
- B. Electrical specifications and performance data contained in this specification document are based on Mini-Circuits' applicable established test performance criteria and measurement instructions.
- C. The parts covered by this specification document are subject to Mini-Circuits' standard limited warranty and terms and conditions (collectively, "Standard Terms"); Purchasers of this part are entitled to the rights and benefits contained therein. For a full statement of the Standard Terms and the exclusive rights and remedies thereunder, please visit Mini-Circuits' website at www.minicircuits.com/MCLStore/terms.jsp



Typical Performance Curves

VSWR

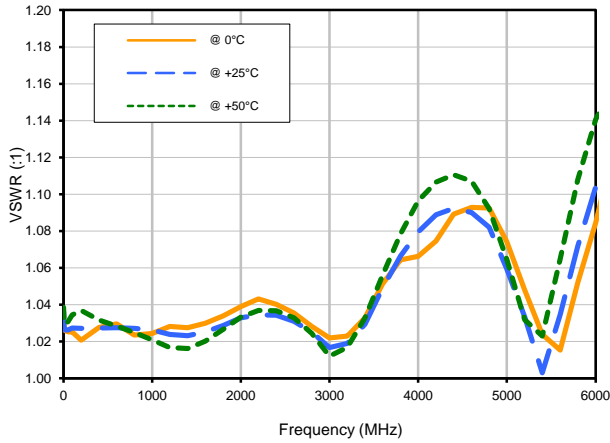

UNCERTAINTY OF POWER MEASUREMENT @ 25°C

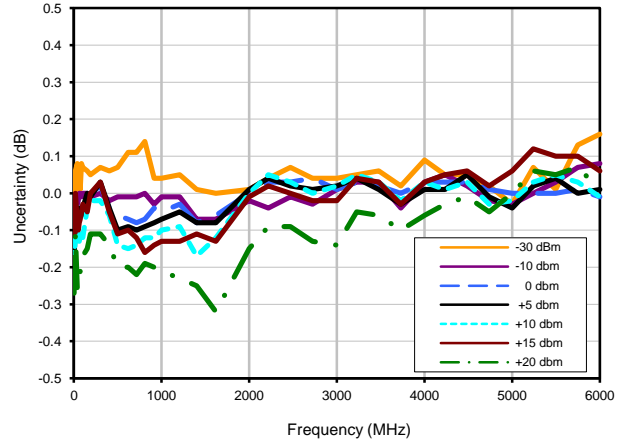

LINEARITY @ 25°C

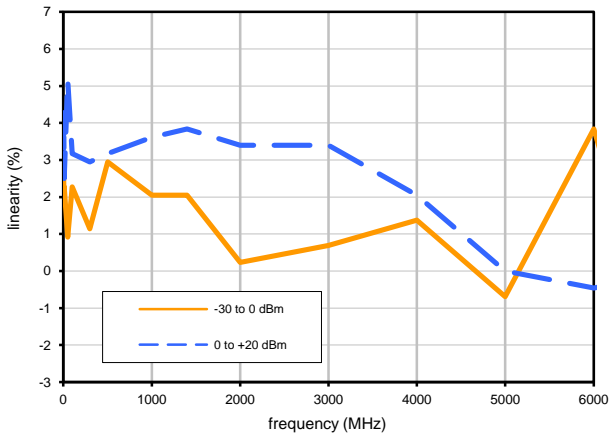

UNCERTAINTY OF FREQ. MEASUREMENT @ 25°C

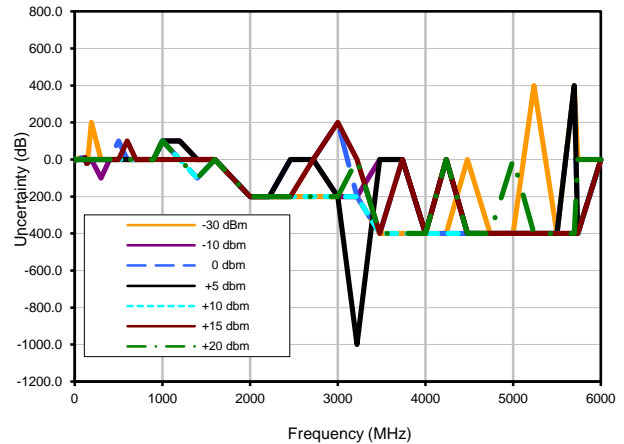

Notes

- A. Performance and quality attributes and conditions not expressly stated in this specification document are intended to be excluded and do not form a part of this specification document.
- B. Electrical specifications and performance data contained in this specification document are based on Mini-Circuits' applicable established test performance criteria and measurement instructions.
- C. The parts covered by this specification document are subject to Mini-Circuits standard limited warranty and terms and conditions (collectively, "Standard Terms"); Purchasers of this part are entitled to the rights and benefits contained therein. For a full statement of the Standard Terms and the exclusive rights and remedies thereunder, please visit Mini-Circuits' website at www.minicircuits.com/MQLStore/terms.jsp



Case Style

Outline Dimensions

JL

JL2029

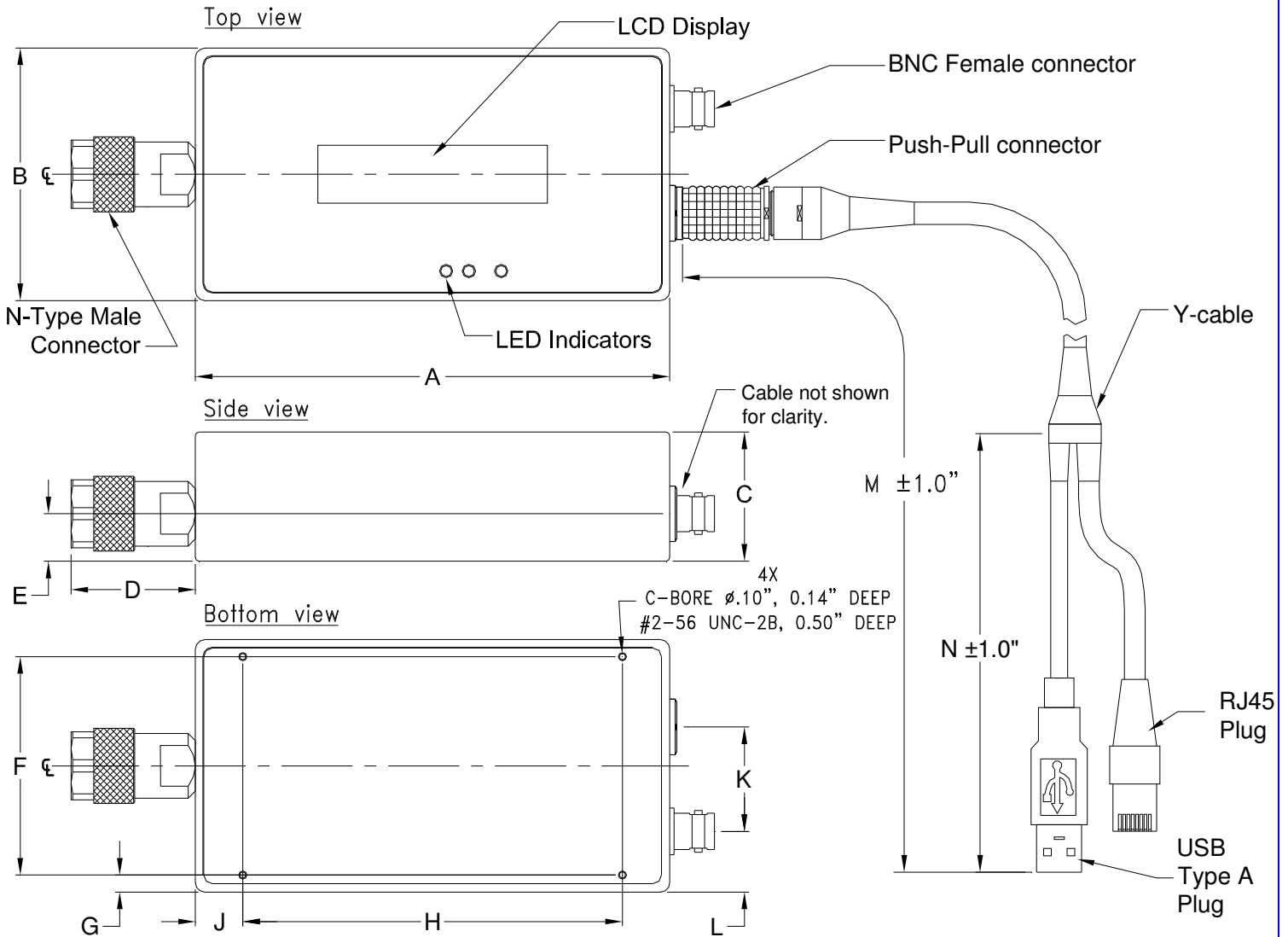

CASE#	A	B	C	D	E	F	G	H	J	K	L	M	N	WT. GRAMS
JL2029	5.00 (127.0)	2.66 (67.6)	1.36 (34.5)	1.31 (33.3)	0.50 (12.7)	2.300 (58.42)	0.18 (4.6)	4.000 (101.60)	0.50 (12.7)	1.100 (27.95)	0.640 (16.25)	80 (2032)	20 (508)	500

Dimensions are in inches (mm). Tolerances: 2 Pl. $\pm .03$; 3 Pl. $\pm .015$

Notes:

1. Case material: Aluminum Alloy
2. Case finish: Clear chemical conversion coating, non-chrome or trivalent chrome based.

Mini-Circuits®

INTERNET <http://www.minicircuits.com>

P.O. Box 350166, Brooklyn, New York 11235-0003 (718) 934-4500 Fax (718) 332-4661

Distribution Centers NORTH AMERICA 800-654-7949 • 417-335-5935 • Fax 417-335-5945 • EUROPE 44-1252-832600 • Fax 44-1252-837010

Mini-Circuits ISO 9001 & ISO 14001 Certified



Environmental Specifications **ENV50**

All Mini-Circuits products are manufactured under exacting quality assurance and control standards, and are capable of meeting published specifications after being subjected to any or all of the following physical and environmental test.

Specification	Test/Inspection Condition	Reference/Spec
Operating Temperature	-0° to 50° C Ambient Environment	Individual Model Data Sheet
Storage Temperature	-30° to 70° C Ambient Environment	Individual Model Data Sheet
Operating and Storage Humidity	5% to 85% RH (non-condensing)	Ambient
Bench Handling Test	Bench Top Tip 45° & Drop	MIL-PRF-28800F
Transit Drop Test	Free Fall Drop, 20 cm (7.9 inches)	MIL-PRF-28800F Class 3