

Surface Mount Voltage Variable Attenuator

EVA-3000+

50Ω 50 to 3000 MHz

Maximum Ratings

Operating Temperature	-45°C to 85°C
Storage Temperature	-55°C to 100°C
Absolute Max. Supply Voltage(V+)	7V
Absolute Max. Control Voltage(Vctrl)	9V
Absolute Max. RF Input Level	+22 dBm
Permanent damage may occur if any of these limits are exceeded.	

Pin Connections

RF IN	1
RF OUT	6
V CONTROL	3
V+	4
GROUND	2,5

Outline Drawing

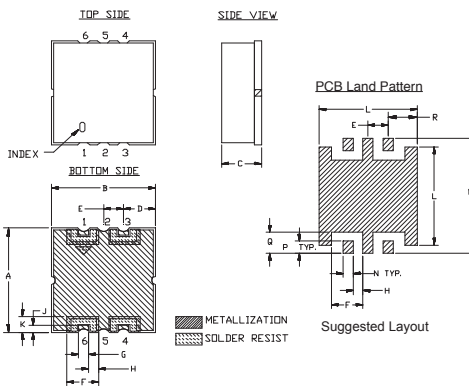

Outline Dimensions (inch/mm)

A	B	C	D	E	F	G	H	
.394	.394	.150	.122	.075	.120	.038	.037	
10.01	10.01	3.81	3.10	1.90	3.05	0.97	0.94	
J	K	L	M	N	P	Q	R	wt.
.026	.061	.370	.434	.038	.046	.081	.110	grams
0.66	1.55	9.40	11.02	0.97	1.17	2.06	2.79	0.7

Demo Board MCL P/N: TB-335 Suggested PCB Layout (PL-187)

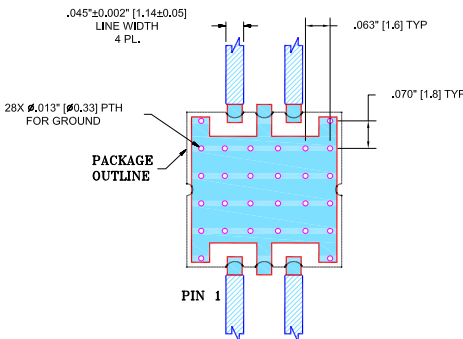

NOTE:

- TRACE WIDTH IS SHOWN FOR FR4 WITH DIELECTRIC THICKNESS. $.025 \pm .002$ ". COPPER: 1/2 OZ. EACH SIDE. FOR OTHER MATERIALS TRACE WIDTH MAY NEED TO BE MODIFIED.
- BOTTOM SIDE OF THE PCB IS CONTINUOUS GROUND PLANE.

- DENOTES PCB COPPER LAYOUT
- DENOTES COPPER LAND PATTERN FREE OF SOLDERMASK

Features

- Frequency range, 50-3000 MHz
- IP3, 45 dBm typ.
- Maximum attenuation at minimum current
- No external bias and RF matching network required
- Small size, shielded case
- Low cost
- Aqueous washable

Applications

- Variable gain amplifier
- Feed forward amplifiers
- ALC circuits



CASE STYLE: HE1135

+RoHS Compliant

The +Suffix identifies RoHS Compliance. See our web site for RoHS Compliance methodologies and qualifications

Electrical Specifications (T_{AMB} = 25°C)

FREQ. (MHz)	MIN. INSERTION LOSS, dB (+8V)		MAX. ATTENUATION dB (0V)		INPUT POWER (dBm)	CONTROL Voltage Current (V) (mA)		IP3 (dBm)	RETURN LOSS (dB)	POWER SUPPLY Voltage Current (V) (mA)	
	Min.	Max.	Typ.	Max.		Max.	Max.			Typ.	Typ.
50 - 1000	2.5	4.0	43	27	+22	0 - 8	40	41	21	+5	5
1000 - 2000	3.0	4.5	29	21	+22	0 - 8	40	45	22	+5	5
2000 - 3000	3.5	5.5	24	17	+22	0 - 8	40	44	18	+5	5

Notes:

Rise/Fall time: 15μSec/36μSec Typ.
Switching Time, turn on/off: 40μSec. Typ.

Equivalent Schematic

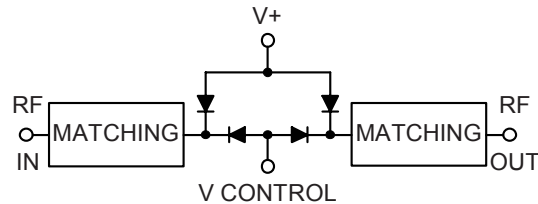

EVA-3000+ TYPICAL ATTENUATION AT 1500MHz

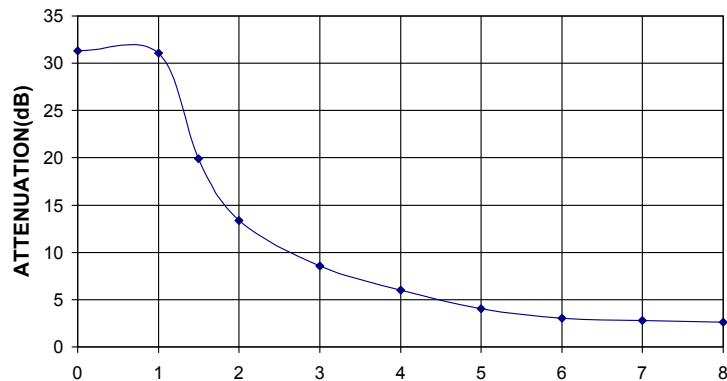

Notes

- Performance and quality attributes and conditions not expressly stated in this specification document are intended to be excluded and do not form a part of this specification document.
- Electrical specifications and performance data contained in this specification document are based on Mini-Circuit's applicable established test performance criteria and measurement instructions.
- The parts covered by this specification document are subject to Mini-Circuits standard limited warranty and terms and conditions (collectively, "Standard Terms"); Purchasers of this part are entitled to the rights and benefits contained therein. For a full statement of the Standard Terms and the exclusive rights and remedies thereunder, please visit Mini-Circuits' website at www.minicircuits.com/MCLStore/terms.jsp



www.minicircuits.com P.O. Box 350166, Brooklyn, NY 11235-0003 (718) 934-4500 sales@minicircuits.com

REV. D
M151108
EVA-3000+
EDR-7165/2
RAV
161211
Page 1 of 2

**EVA-3000+
ATTENUATION Vs. FREQUENCY
OVER CONTROL VOLTAGES**

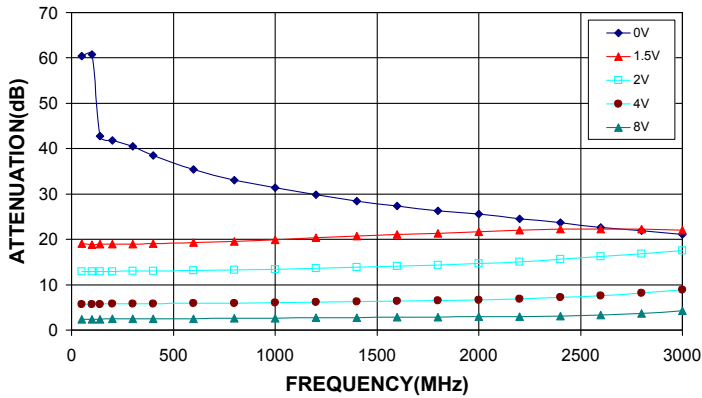

**EVA-3000+
ATTENUATION Vs. INPUT POWER
OVER CONTROL VOLTAGES AT 900MHZ**

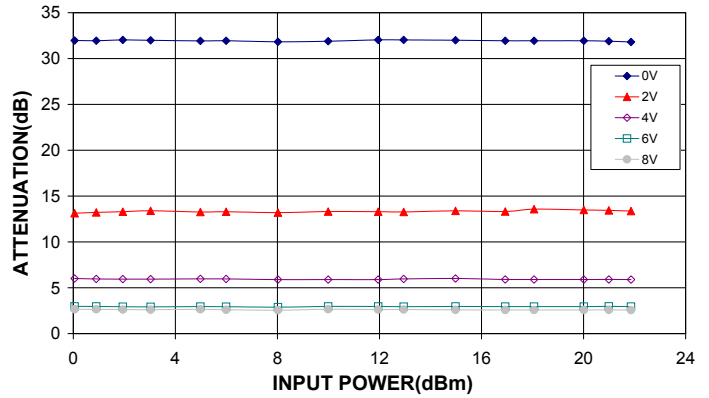

**EVA-3000+
INPUT RETURN LOSS Vs. FREQUENCY
OVER CONTROL VOLTAGES**

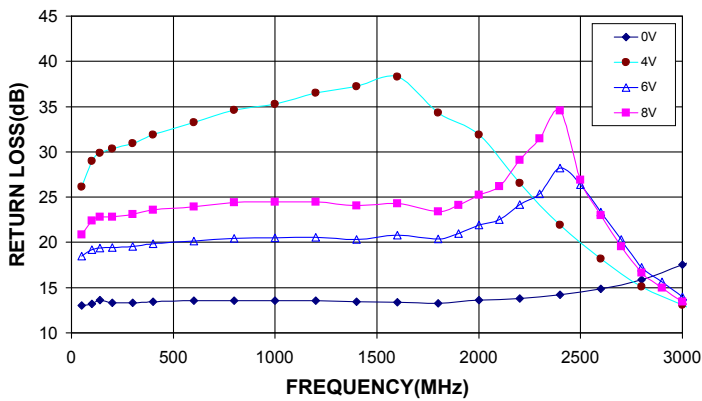

**EVA-3000+
OUTPUT RETURN LOSS Vs. FREQUENCY
OVER CONTROL VOLTAGES**

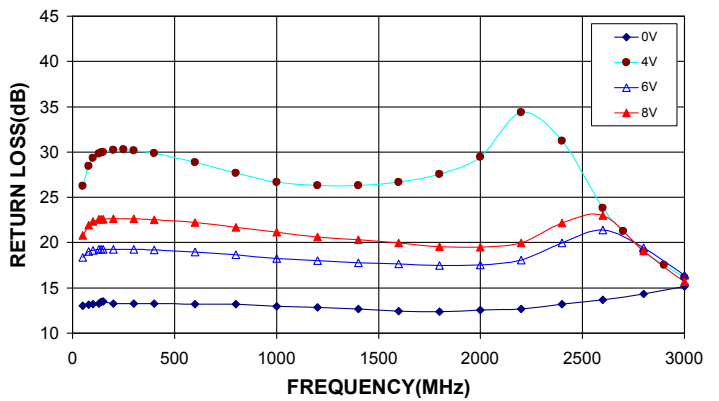

**EVA-3000+
IP3 Vs. FREQUENCY
OVER CONTROL VOLTAGES**

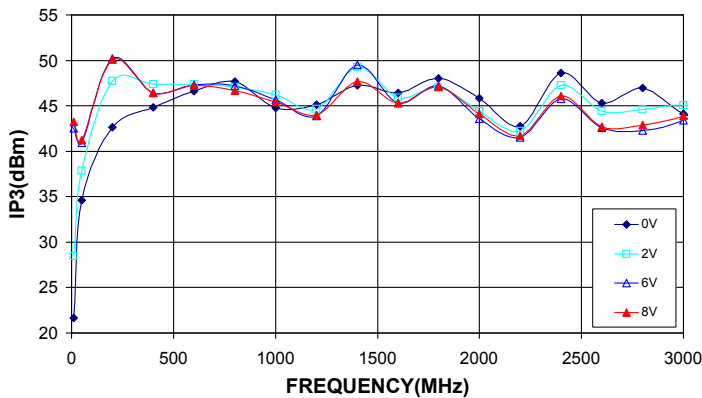

**EVA-3000+
PHASE SHIFT Vs. FREQUENCY
OVER CONTROL VOLTAGES**

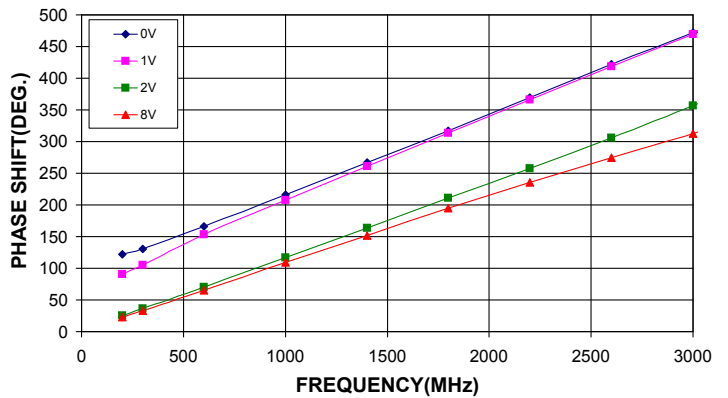

Notes

- A. Performance and quality attributes and conditions not expressly stated in this specification document are intended to be excluded and do not form a part of this specification document.
- B. Electrical specifications and performance data contained in this specification document are based on Mini-Circuit's applicable established test performance criteria and measurement instructions.
- C. The parts covered by this specification document are subject to Mini-Circuits standard limited warranty and terms and conditions (collectively, "Standard Terms"); Purchasers of this part are entitled to the rights and benefits contained therein. For a full statement of the Standard Terms and the exclusive rights and remedies thereunder, please visit Mini-Circuits' website at www.minicircuits.com/MCLStore/terms.jsp



Voltage Variable Attenuator

EVA-3000+

Typical Performance Data

V CONTROL (V)	ATTENUATION @ 1500 MHz (dB) @V+=5V
0.0	31.33
1.0	31.09
1.5	19.89
2.0	13.38
3.0	8.55
4.0	6.03
5.0	4.05
6.0	3.02
7.0	2.77
8.0	2.59

FREQ. (MHz)	ATTENUATION Vs. V CONTROL @ V+=5V				
	(dB)				
	@V Control=0V	@V Control=1.5V	@V Control=2V	@V Control=4V	@V Control=8V
50	60.46	19.09	12.96	5.74	2.42
80	60.04	18.90	12.92	5.71	2.39
100	60.82	18.88	12.92	5.71	2.41
130	50.18	18.91	12.93	5.72	2.40
140	42.72	18.91	12.96	5.74	2.42
150	39.42	18.91	12.95	5.75	2.42
200	41.76	18.93	12.95	5.76	2.45
250	41.40	18.94	12.98	5.79	2.45
300	40.53	19.00	13.00	5.80	2.46
350	39.56	19.01	13.01	5.80	2.47
400	38.54	19.08	13.04	5.80	2.50
500	36.79	19.17	13.08	5.85	2.50
600	35.45	19.28	13.13	5.87	2.51
700	34.13	19.43	13.17	5.93	2.55
800	33.07	19.56	13.25	5.95	2.57
900	31.93	19.72	13.29	5.95	2.56
1000	31.33	19.89	13.38	6.03	2.59
1100	30.49	20.12	13.50	6.12	2.63
1200	29.80	20.34	13.62	6.13	2.71
1300	29.07	20.56	13.74	6.22	2.73
1400	28.43	20.71	13.87	6.25	2.71
1500	27.74	20.94	13.98	6.33	2.77
1600	27.34	21.09	14.11	6.41	2.84
1700	26.88	21.22	14.19	6.45	2.83
1800	26.26	21.32	14.31	6.48	2.81
1900	25.79	21.55	14.50	6.58	2.86
2000	25.55	21.73	14.71	6.68	2.92
2100	25.07	21.89	14.91	6.80	2.97
2200	24.51	21.98	15.07	6.87	2.95
2300	24.05	22.11	15.34	7.03	3.02
2400	23.70	22.22	15.59	7.19	3.09
2500	23.29	22.34	15.94	7.39	3.19
2600	22.65	22.25	16.23	7.63	3.29
2700	22.35	22.21	16.54	7.89	3.49
2800	21.94	22.22	16.85	8.16	3.72
2900	21.60	22.10	17.12	8.47	3.93
3000	21.05	22.01	17.49	8.87	4.26



IR/RF MICROWAVE COMPONENTS • ISO 9001 ISO 14001 AS 9100 CERTIFIED • RoHS compliant
P.O. Box 350166, Brooklyn, New York 11235-0003 (718) 934-4500 Fax (718) 332-4661



The Design Engineers Search Engine finds the model you need, Instantly • For detailed performance specs & shopping online see



REV. X1
EVA-3000+
070704

Page 1 of 5

Voltage Variable Attenuator

EVA-3000+

Typical Performance Data

FREQ. (MHz)	INPUT RETURN LOSS Vs. V CONTROL @ V+=5V				
	(dB)				
	@V Control=0V	@V Control=2V	@V Control=4V	@V Control=6V	@V Control=8V
50	13.02	23.02	26.12	18.47	20.86
80	13.13	23.34	28.31	19.06	22.07
100	13.18	23.45	28.97	19.20	22.41
130	13.35	23.57	29.67	19.36	22.70
140	13.59	23.60	29.90	19.39	22.80
150	13.69	23.61	30.04	19.42	22.88
200	13.31	23.75	30.35	19.41	22.83
250	13.34	23.89	30.68	19.54	23.05
300	13.33	23.85	30.93	19.58	23.12
350	13.35	24.00	31.08	19.60	23.20
400	13.44	24.33	31.91	19.84	23.58
500	13.54	24.75	32.71	20.01	23.83
600	13.55	25.00	33.25	20.13	23.97
700	13.55	25.21	33.96	20.37	24.33
800	13.55	25.55	34.62	20.44	24.41
900	13.60	25.86	35.18	20.52	24.68
1000	13.56	25.93	35.30	20.49	24.50
1100	13.54	26.33	35.11	20.42	24.37
1200	13.53	26.89	36.54	20.58	24.45
1300	13.48	26.94	36.41	20.42	24.31
1400	13.46	27.52	37.25	20.31	24.03
1500	13.39	27.65	37.29	20.49	24.08
1600	13.38	27.95	38.29	20.79	24.29
1700	13.30	27.34	34.93	20.29	23.43
1800	13.28	27.19	34.34	20.41	23.41
1900	13.38	26.90	34.04	20.96	24.13
2000	13.63	26.39	31.87	21.90	25.23
2100	13.58	24.98	29.80	22.50	26.18
2200	13.77	23.11	26.54	24.17	29.10
2300	14.04	21.87	24.69	25.36	31.46
2400	14.22	20.20	21.90	28.24	34.55
2500	14.50	18.99	19.95	26.36	26.92
2600	14.87	17.90	18.19	23.32	22.99
2700	15.18	17.05	16.65	20.33	19.57
2800	15.89	16.14	15.12	17.24	16.63
2900	16.40	15.48	14.07	15.61	15.00
3000	17.55	14.82	13.06	13.98	13.42

REV. X1
EVA-3000+
070704
Page 2 of 5



IF/RF MICROWAVE COMPONENTS • ISO 9001 ISO 14001 AS 9100 CERTIFIED • RoHS compliant
P.O. Box 350166, Brooklyn, New York 11235-0003 (718) 934-4500 Fax (718) 332-4661



The Design Engineers Search Engine finds the model you need, Instantly • For detailed performance specs & shopping online see



Voltage Variable Attenuator

EVA-3000+

Typical Performance Data

FREQ. (MHz)	OUTPUT RETURN LOSS Vs. V CONTROL @ V+=5V				
	(dB)				
	@V Control=0V	@V Control=2V	@V Control=4V	@V Control=6V	@V Control=8V
50	13.01	23.06	26.25	18.39	20.77
80	13.14	23.34	28.44	18.99	21.95
100	13.20	23.56	29.31	19.16	22.34
130	13.29	23.60	29.84	19.24	22.55
140	13.43	23.54	29.92	19.24	22.59
150	13.48	23.51	30.01	19.24	22.60
200	13.28	23.64	30.22	19.26	22.66
250	13.29	23.66	30.28	19.31	22.67
300	13.27	23.59	30.15	19.24	22.65
350	13.30	23.61	29.98	19.18	22.59
400	13.29	23.57	29.85	19.19	22.51
500	13.29	23.47	29.43	19.08	22.34
600	13.23	23.32	28.86	18.97	22.21
700	13.19	23.17	28.42	18.90	22.06
800	13.18	23.03	27.70	18.68	21.71
900	13.13	22.94	27.49	18.64	21.67
1000	12.98	22.62	26.69	18.25	21.13
1100	12.88	22.50	26.42	18.15	20.93
1200	12.85	22.60	26.31	17.99	20.64
1300	12.79	22.73	26.33	17.95	20.57
1400	12.65	22.69	26.32	17.77	20.30
1500	12.52	22.78	26.12	17.54	19.91
1600	12.46	23.27	26.69	17.67	19.97
1700	12.40	23.74	26.84	17.32	19.42
1800	12.36	24.46	27.58	17.45	19.53
1900	12.42	25.47	28.27	17.38	19.34
2000	12.54	27.15	29.43	17.53	19.48
2100	12.62	29.46	32.22	18.01	20.00
2200	12.64	31.96	34.36	18.07	19.96
2300	12.84	38.98	35.82	18.96	21.16
2400	13.19	43.09	31.22	19.94	22.18
2500	13.42	32.98	26.77	20.73	22.79
2600	13.67	28.62	23.84	21.38	22.97
2700	14.01	25.64	21.29	20.43	20.96
2800	14.34	23.15	19.03	19.44	19.10
2900	14.71	21.37	17.56	18.09	17.49
3000	15.14	20.01	16.19	16.41	15.68

REV. X1
EVA-3000+
070704
Page 3 of 5



IF/RF MICROWAVE COMPONENTS • ISO 9001 ISO 14001 AS 9100 CERTIFIED RoHS compliant
P.O. Box 350166, Brooklyn, New York 11235-0003 (718) 934-4500 Fax (718) 332-4661



The Design Engineers Search Engine finds the model you need, Instantly • For detailed performance specs & shopping online see



Voltage Variable Attenuator

EVA-3000+

Typical Performance Data

FREQ. (MHz)	INPUT IP3 Vs. V CONTROL @ V+=5V				
	(dBm)				
	@V Control=0V	@V Control=2V	@V Control=4V	@V Control=6V	@V Control=8V
10	21.63	28.44	31.22	42.50	43.24
20	30.15	33.24	35.58	45.89	46.40
50	34.60	37.83	39.17	40.90	41.25
100	35.86	42.54	44.54	45.95	46.48
200	42.67	47.73	50.86	50.19	50.12
300	44.40	47.81	48.58	48.77	48.50
400	44.81	47.37	48.56	46.40	46.45
500	46.08	47.97	50.96	52.11	52.52
600	46.63	47.36	48.88	47.29	47.23
700	47.29	49.86	50.54	49.56	51.86
800	47.67	47.10	48.06	47.18	46.69
900	46.93	47.51	47.67	46.13	46.02
1000	44.76	46.19	45.58	45.65	45.42
1100	46.73	49.89	49.37	49.27	49.72
1200	45.10	44.65	45.31	43.87	43.99
1300	47.29	45.84	46.59	47.30	46.67
1400	47.24	49.24	51.11	49.53	47.67
1500	45.90	46.28	45.92	45.96	45.12
1600	46.40	45.88	45.70	45.29	45.33
1700	46.18	45.74	47.38	46.31	46.74
1800	48.03	47.00	48.65	47.17	47.08
1900	44.00	43.26	44.01	43.04	43.09
2000	45.83	44.43	43.66	43.56	44.11
2100	47.88	46.32	45.61	44.65	45.46
2200	42.75	42.23	42.48	41.52	41.69
2300	45.67	44.23	43.96	42.90	43.24
2400	48.63	47.26	47.12	45.80	46.05
2500	43.82	42.03	42.57	41.04	41.58
2600	45.29	44.41	43.92	42.59	42.72
2700	48.97	48.59	47.01	44.50	44.51
2800	46.95	44.59	45.40	42.28	42.89
2900	49.16	49.88	49.12	45.75	45.21
3000	44.12	45.06	44.11	43.44	43.90

REV. X1
EVA-3000+
070704
Page 4 of 5



IF/RF MICROWAVE COMPONENTS • ISO 9001 ISO 14001 AS 9100 CERTIFIED • RoHS compliant
P.O. Box 350166, Brooklyn, New York 11235-0003 (718) 934-4500 Fax (718) 332-4661



The Design Engineers Search Engine finds the model you need, Instantly • For detailed performance specs & shopping online see



Voltage Variable Attenuator

EVA-3000+

Typical Performance Data

FREQ. (MHz)	PHASE SHIFT Vs. V CONTROL @ V+=5V (deg)				
	@V Control=0V	@V Control=1V	@V Control=2V	@V Control=4V	@V Control=8V
200	121.81	90.27	25.09	22.89	22.76
300	130.40	105.44	36.12	33.69	33.28
600	165.77	153.30	70.34	66.31	65.33
1000	216.10	207.69	117.13	110.54	108.97
1400	266.93	261.22	163.79	153.80	151.85
1800	317.31	313.28	211.04	197.42	194.83
2200	369.57	366.29	257.98	239.43	235.67
2600	421.84	418.43	305.72	279.97	274.25
3000	472.21	469.30	356.67	321.32	312.69

REV. X1
EVA-3000+
070704
Page 5 of 5



IF/RF MICROWAVE COMPONENTS • ISO 9001 ISO 14001 AS 9100 CERTIFIED RoHS compliant
P.O. Box 350166, Brooklyn, New York 11235-0003 (718) 934-4500 Fax (718) 332-4661



The Design Engineers Search Engine finds the model you need, Instantly • For detailed performance specs & shopping online see



Voltage Variable Attenuator

Typical Performance Curves

EVA-3000+

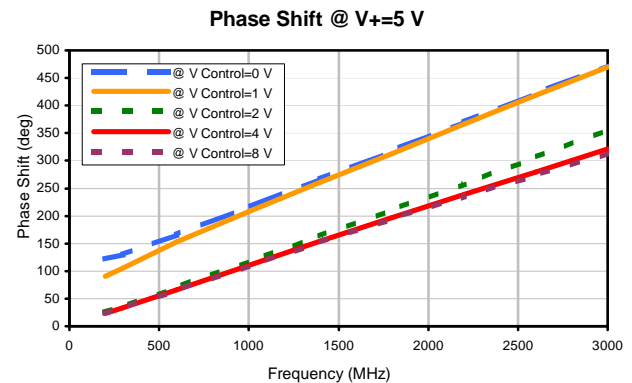
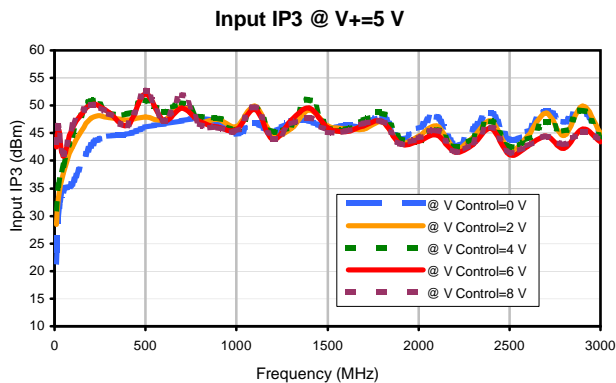
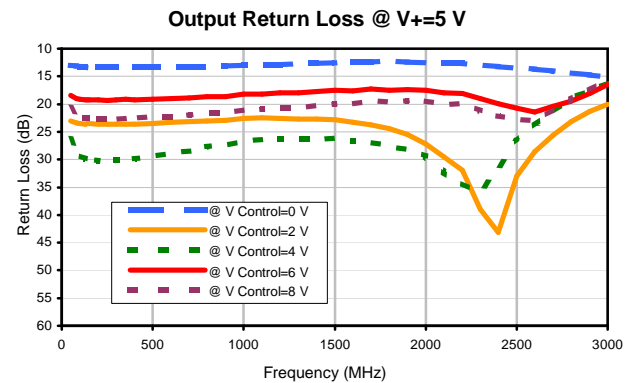
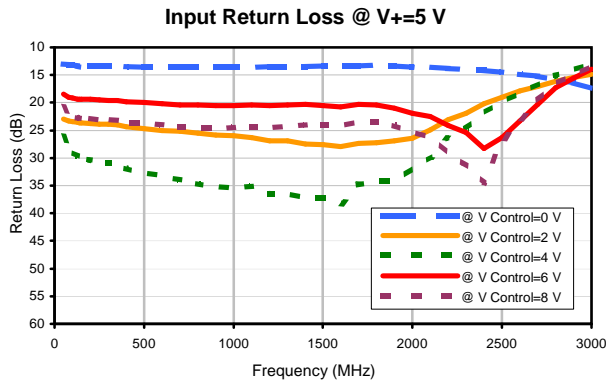
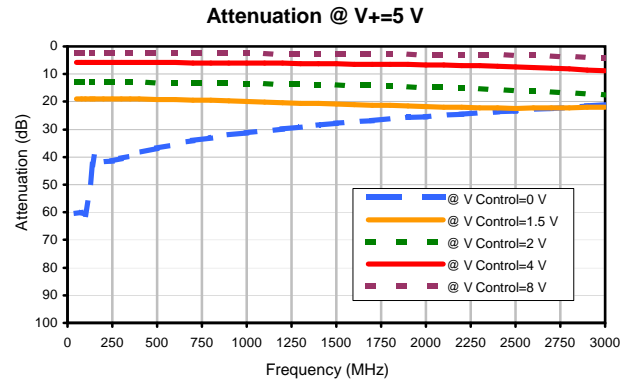
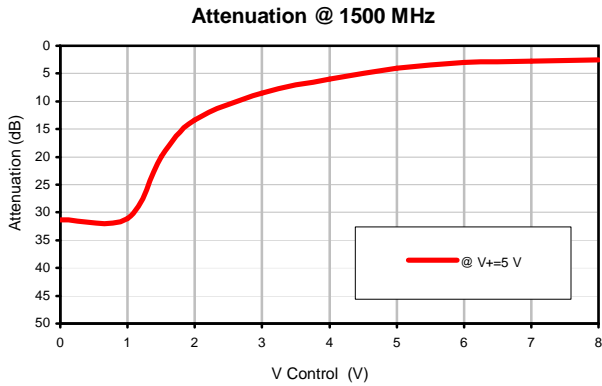

REV. X1
EVA-3000+
070704
Page 1 of 1

Mini-Circuits®

IF/RF MICROWAVE COMPONENTS • ISO 9001 ISO 14001 AS 9100 CERTIFIED RoHS compliant
P.O. Box 350166, Brooklyn, New York 11235-0003 (718) 934-4500 Fax (718) 332-4661



The Design Engineers Search Engine finds the model you need, Instantly • For detailed performance specs & shopping online see



Outline Dimensions

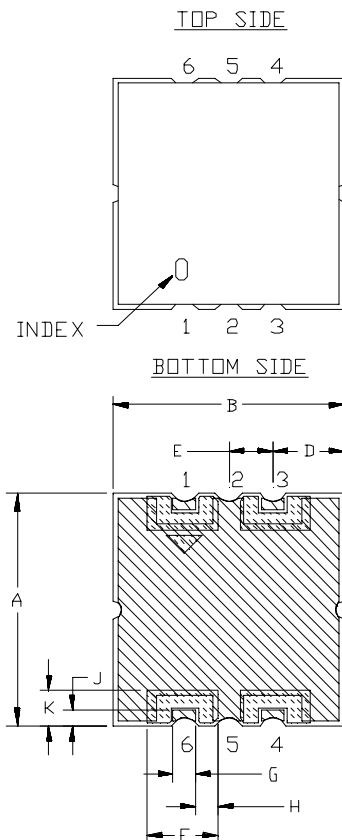

SIDE VIEW

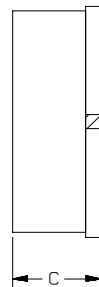

PCB Land Pattern

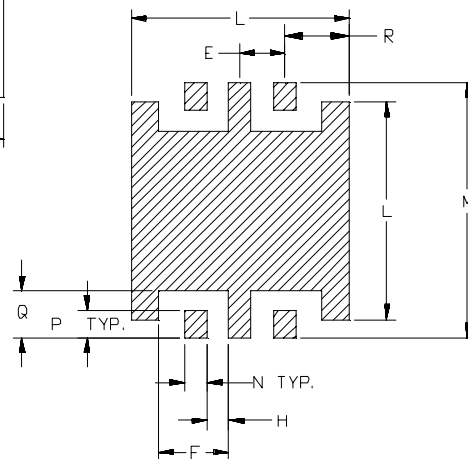

Suggested Layout

 METALLIZATION
 SOLDER RESIST

CASE #	A	B	C	D	E	F	G	H	J	K	L	M	N	P
HE1135	.394 (10.01)	.394 (10.01)	.150 (3.81)	.122 (3.10)	.075 (1.90)	.120 (3.05)	.038 (0.97)	.037 (0.94)	.026 (0.66)	.061 (1.55)	.370 (9.40)	.434 (11.02)	.038 (0.97)	.046 (1.17)

CASE #	Q	R	WT. GRAMS
HE1135	.081 (2.06)	.110 (2.79)	0.7

Dimensions are in inches (mm). Tolerances: 2 Pl. $\pm .03$; 3 Pl. $\pm .015$

Notes:

- Case material: Nickel-Silver alloy.
- Base: Printed wiring laminate.
- Termination finish:
 For RoHS Case Styles: 3-5 μ inch (.08-.13 microns) Gold over 120-240 μ inch (3.05-6.10 microns) Nickel plate.
 For RoHS-5 Case Styles: Tin-Lead plate.



 ISO 9001 ISO 14001 CERTIFIED

ALL NEW
minicircuits.com

P.O. Box 350166, Brooklyn, New York 11235-0003 (718) 934-4500 Fax (718) 332-4661 For detailed performance specs & shopping online see Mini-Circuits web site



The Design Engineers Search Engine Provides ACTUAL Data Instantly From MINI-CIRCUITS At: www.minicircuits.com

RF/IF MICROWAVE COMPONENTS

Tape & Reel Packaging TR-F37

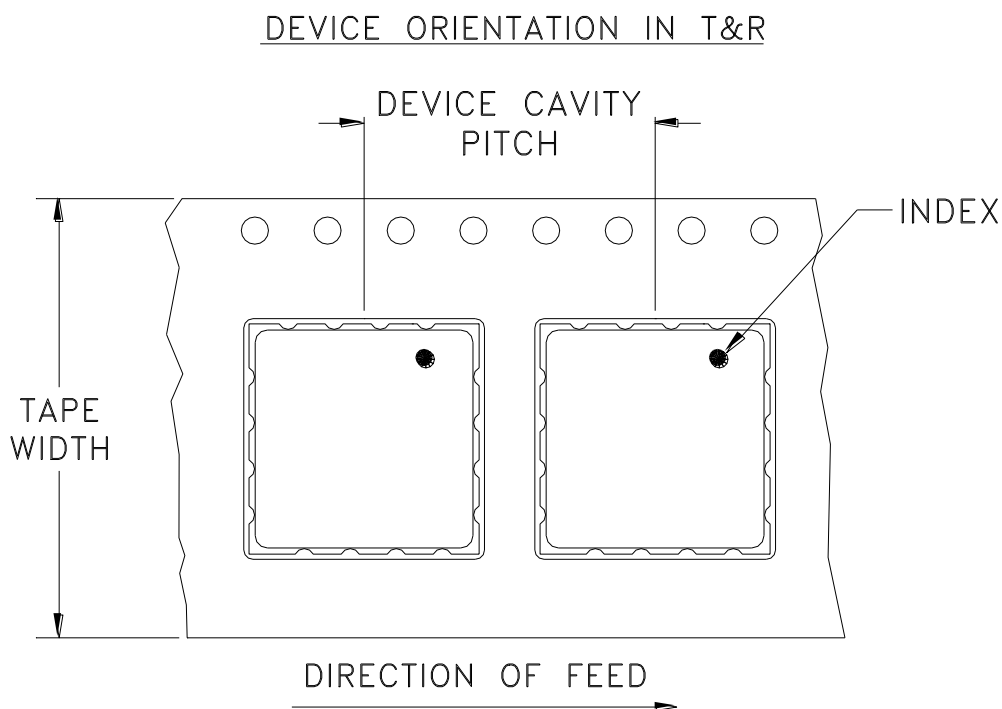

Tape Width, mm	Device Cavity Pitch, mm	Reel Size, inches	Devices per Reel	
24	16	7	Small quantity standards (see note)	10
				20
				50
				100
		13	Standard	200
500				

Note: Please consult individual model data sheet to determine device per reel availability.

Mini-Circuits carrier tape materials provide protection from ESD (Electro-Static Discharge) during handling and transportation. Tapes are static dissipative and comply with industry standards EIA-481/EIA-541.

Go to: www.minicircuits.com/pages/pdfs/tape.pdf



INTERNET <http://www.minicircuits.com>

P.O. Box 350166, Brooklyn, New York 11235-0003 (718) 934-4500 Fax (718) 332-4661

Distribution Centers NORTH AMERICA 800-654-7949 • 417-335-5935 • Fax 417-335-5945 • EUROPE 44-1252-832600 • Fax 44-1252-837010

Mini-Circuits ISO 9001 & ISO 14001 Certified

THIRD ANGLE PROJECTION

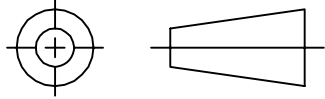

REVISIONS

REV	ECN No.	DESCRIPTION	DATE	DR	AUTH
OR	M97072	NEW RELEASE (FROM RAVON)	05/05	DK	HH
A	M102713	ADDED "...WITH SMOBC"	01/06	GT	IL
B	M121588	UPDATE GROUND PLANE	02/09	EM	HH
B	R75766	UPDATE GROUND PLANE	02/09	EM	HH

SUGGESTED MOUNTING CONFIGURATION

FOR HE1135 CASE STYLE, qg PIN CONNECTION, 50 OHM.

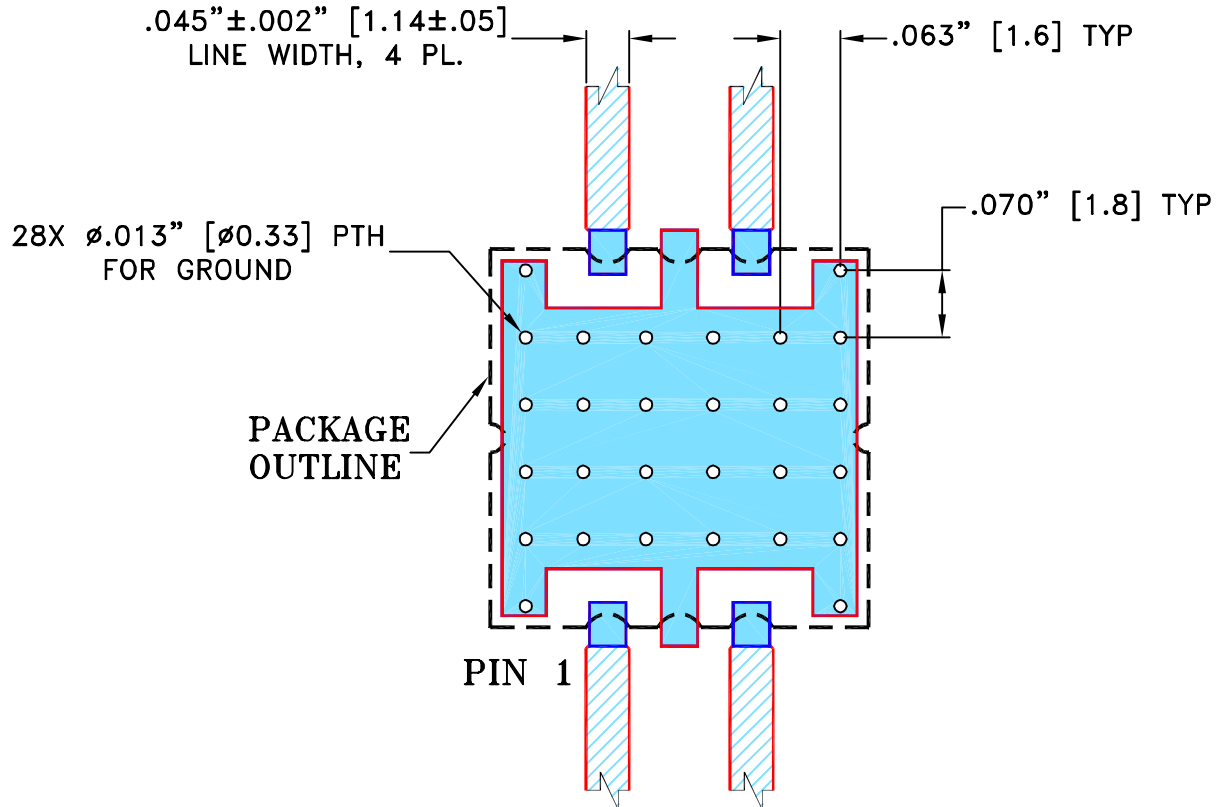

NOTE:

1. TRACE WIDTH IS SHOWN FOR FR4 WITH DIELECTRIC THICKNESS $.025" \pm .002"$. COPPER: 1/2 OZ. EACH SIDE.
FOR OTHER MATERIALS TRACE WIDTH MAY NEED TO BE MODIFIED.
2. BOTTOM SIDE OF THE PCB IS CONTINUOUS GROUND PLANE.



DENOTES PCB COPPER LAYOUT



DENOTES COPPER LAND PATTERN FREE OF SOLDER MASK

UNLESS OTHERWISE SPECIFIED	INITIALS		DATE
DIMENSIONS ARE IN INCHES TOLERANCES ON: 2 PL DECIMALS ± 3 PL DECIMALS ± .005 ANGLES ± FRACTIONS ±	DRAWN	DK (RAVON)	03 MAY 05
	CHECKED	RZ (RAVON)	03 MAY 05
	APPROVED	HH (RAVON)	03 MAY 05



Mini-Circuits® 13 Neptune Avenue
Brooklyn NY 11235

**PL, qg, HE1135, TB-335,
50 OHM**

SIZE A	CODE IDENT 15542	DRAWING NO: 98-PL-187	REV: B
FILE: 98PL187	SCALE: 5:1	SHEET: 1 OF 1	

Mini-Circuits®
THIS DOCUMENT AND ITS CONTENTS ARE THE PROPERTY OF MINI-CIRCUITS.
EXCEPT FOR USE EXPRESSLY GRANTED, IN WRITING, TO ITS VENDORS, VENDEE
AND THE UNITED STATES GOVERNMENT, MINI-CIRCUITS RESERVES ALL PROPRIETARY
DESIGN, USE, MANUFACTURING AND REPRODUCTION RIGHTS THERETO.
THESE CONTENTS SHALL NOT BE USED, DUPLICATED OR DISCLOSED TO ANY OUTSIDE
PARTY, IN WHOLE OR IN PART, WITHOUT WRITTEN PERMISSION OF MINI-CIRCUITS.

Evaluation Board and Circuit

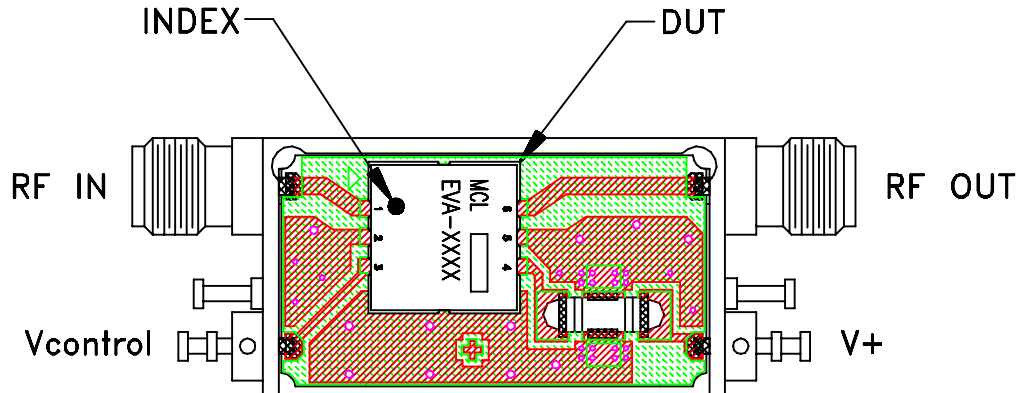

TB-335

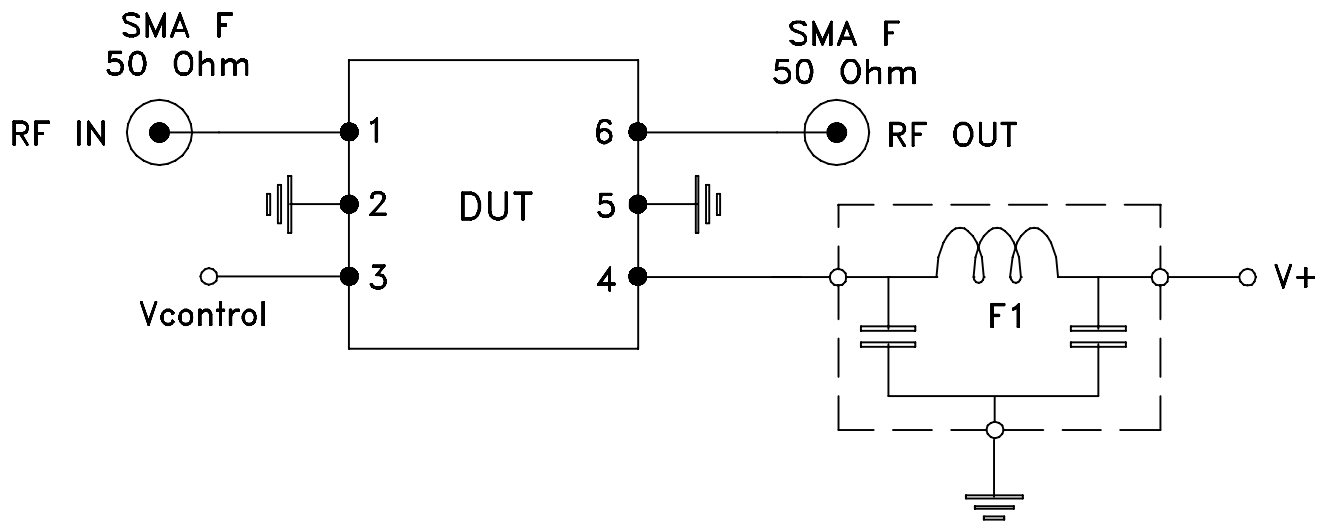

Schematic Diagram

Notes:

1. SMA Female connectors.
2. PCB Material: FR4 GRADE IT-180TC (ITEQ CORPORATION)
Dielectric Constant=4.5, Thickness=.025 inch.

 **Mini-Circuits®**



All Mini-Circuits products are manufactured under exacting quality assurance and control standards, and are capable of meeting published specifications after being subjected to any or all of the following physical and environmental test.

Specification	Test/Inspection Condition	Reference/Spec
Operating Temperature	-45° to 85°C Ambient Environment	Individual Model Data Sheet
Storage Temperature	-55° to 100° C Ambient Environment	Individual Model Data Sheet
Humidity	90 to 95% RH, 240 hours, 50°C	MIL-STD-202, Method 103, Condition A, Except 50°C and end-point electrical test done within 12 hours
Thermal Shock	-55° to 100°C, 100 cycles	MIL-STD-202, Method 107, Condition A-3, except +100°C
Solder Reflow Heat	Sn-Pb Eutectic Process: 225°C peak Pb-Free Process, 245°C peak	J-STD-020, Table 4-1, 4-2 and 5-2, Figure 5-1
Solderability	10X Magnification	J-STD-002, Para 4.2.5, Test S, 95% Coverage
Vibration (High Frequency)	20g peak, 20-2000 Hz, 4 times in each of three axes (total 12)	MIL-STD-883, Method 2007.3, Condition A
Mechanical Shock	50g, 11 ms, 1/2-sine, 18 shocks: 3 each direction, each of 3 axes	MIL-STD-202, Method 213, Condition A
Marking Resistance to Solvents	Isopropyl alcohol + mineral spirits at 25°C; terpene defluxer at 25°C; distilled water + proylene glycol monomethyl ether + monoethanolamine at 63°C to 70°C	MIL-STD-202, Method 215