



MMIC SURFACE MOUNT

Power Splitter/Combiner

EP4KA+

4 Way-0° 50Ω 10.7 to 31 GHz

THE BIG DEAL

- Wide bandwidth, 10.7 to 31 GHz
- Excellent isolation, 20 dB typ. at 21 GHz
- Excellent amplitude unbalance, 0.2 dB typ. at 21 GHz
- Small size, 5x5 mm
- Aqueous washable

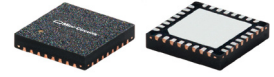

Generic photo used for illustration purposes only
CASE STYLE: DG1677-2

+RoHS Compliant

The +Suffix identifies RoHS Compliance. See our web site for RoHS Compliance methodologies and qualifications

APPLICATIONS

- Instrumentation
- Radar
- Satellite communications
- 5G

PRODUCT OVERVIEW

Mini-Circuits' EP4KA+ is a MMIC 4-way 0° splitter/combiner designed for wideband operation from 10.7 to 31 GHz supporting many applications requiring high performance across a wide frequency range including LTE bands through phased array radars, 5G, as well as instrumentation and more. This model provides good isolation, and low phase and amplitude unbalance in a small 5 x 5mm QFN package. Manufactured using GaAs IPD technology, the EP4KA+ not only provides a repeatable performance, but also a high level of ESD protection.

KEY FEATURES

Feature	Advantages
Wideband, 10.7 to 31 GHz	One power splitter can be used for wideband applications such as 5G, phased array radars, military and instrumentation.
Excellent Amplitude and phase unbalance: amplitude unbalance, 0.2 dB typ. at 21 GHz phase unbalance, 7° typ. at 21 GHz	Ideal for Applications such as MIMO & phased array radars
DC Passing	DC current passing is helpful in applications where both RF & DC need to pass through the DUT, such as antenna mounted hardware.
Small size, 5 x 5mm QFN package	Tiny footprint saves space in dense layouts while providing low inductance, repeatable transitions, and excellent thermal contact to the PCB.





ELECTRICAL SPECIFICATIONS¹ AT 25°C

Parameter	Frequency (GHz)	Min.	Typ.	Max.	Unit
Frequency Range		10.7		31	GHz
Insertion Loss above 6.0 dB	10.7 - 13		0.4	2.1	dB
	13 - 22		0.6	2.4	
	22 - 31		1.1	2.6	
Isolation	10.7 - 13	9	13.1		dB
	13 - 22	11	19.3		
	22 - 31	14	21.5		
Phase Unbalance	10.7 - 13		2.7	—	Degree
	13 - 22		4.7	—	
	22 - 31		7.8	—	
Amplitude Unbalance	10.7 - 13		0.3	0.8	dB
	13 - 22		0.2	0.8	
	22 - 31		0.2	0.9	
VSWR (Port S)	10.7 - 13		1.2		:1
	13 - 22		1.3		
	22 - 31		1.2		
VSWR (Port 1-4)	10.7 - 13		1.4		:1
	13 - 22		1.3		
	22 - 31		1.2		
Power Handling	As a splitter	10.7-31	—	0.6	W
	Per port as a combiner	10.7-31	—	0.6	

1. Tested on Mini-Circuits Test Board TB-EP4KAC+

MAXIMUM RATINGS

Parameter	Ratings
Operating temperature	-55°C to 105°C
Storage temperature	-65°C to 150°C
DC Current	100mA

Permanent damage may occur if any of these limits are exceeded.

PAD CONNECTIONS

Function	Pad Number
SUM PORT	21
PORT 1	14
PORT 2	10
PORT 3	31
PORT 4	27
GROUND	9,11,13,15,20,22,26,28,30,32 and Paddle
NOT USED, GROUND EXTERNALLY	1-8, 12, 16-19, 23-25, 29

PRODUCT MARKING

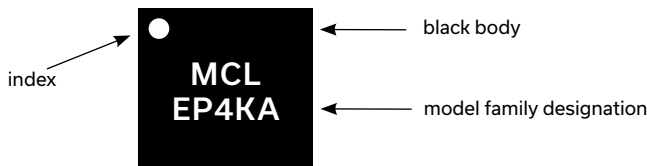

Marking may contain other features or characters for internal lot control

SIMPLIFIED ELECTRICAL SCHEMATIC

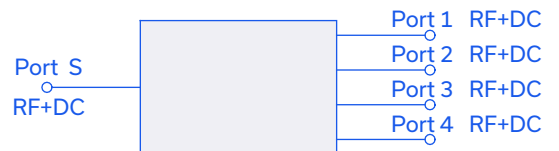



ADDITIONAL DETAILED TECHNICAL INFORMATION IS AVAILABLE ON OUR DASH BOARD. TO ACCESS [CLICK HERE](#)

Performance Data	Data Table Swept Graphs S-Parameter (S3P Files) Data Set (.zip file)
Case Style	DG1677-2 Plastic package, exposed paddle; lead finish: Matte Tin
Tape & Reel Standard quantities available on reel	F68 7" reels with 20, 50, 100, 200, 500 & 1000 devices
Suggested Layout for PCB Design	PL-649
Evaluation Board	TB-EP4KA+ (Without connectors) TB-EP4KAC+ (With connectors)
Environmental Ratings	ENV08T1

ESD RATING

Human Body Model (HBM): Class 2 (Pass 2000V) in accordance with ANSI/ESD STM 5.1 - 2001

MSL TEST FLOW CHART

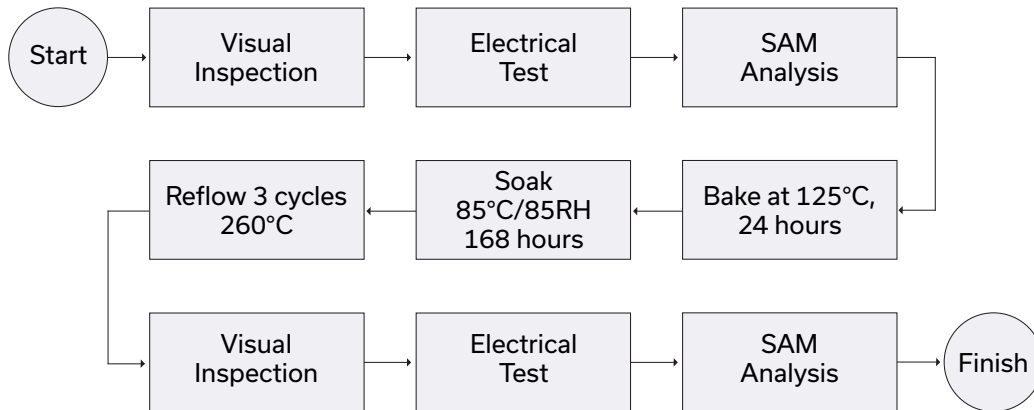

- NOTES**
- A. Performance and quality attributes and conditions not expressly stated in this specification document are intended to be excluded and do not form a part of this specification document.
 - B. Electrical specifications and performance data contained in this specification document are based on Mini-Circuit's applicable established test performance criteria and measurement instructions.
 - C. The parts covered by this specification document are subject to Mini-Circuits standard limited warranty and terms and conditions (collectively, "Standard Terms"); Purchasers of this part are entitled to the rights and benefits contained therein. For a full statement of the standard. Terms and the exclusive rights and remedies thereunder, please visit Mini-Circuits' website at www.minicircuits.com/MCLStore/terms.jsp

4 Way-0° Power Splitter/Combiner

EP4KA+

Typical Performance Data

TEST CONDITIONS: Input Power = -10dBm @Temperature = +25°C

FREQ. (MHz)	TOTAL LOSS ⁽¹⁾				AMP. UNBAL. (dB)	PHASE UNBAL. (deg.)	ISOLATION			VSWR				
	(dB)						(dB)			(-1)				
	S-1	S-2	S-3	S-4			1-2	2-3	3-4	S	1	2	3	4
10700	6.52	6.57	6.31	6.31	0.27	4.83	19.58	11.80	19.40	1.24	1.48	1.47	1.43	1.57
10800	6.52	6.56	6.32	6.30	0.26	4.84	19.69	11.88	19.52	1.25	1.47	1.44	1.42	1.54
11000	6.52	6.53	6.36	6.32	0.21	4.91	19.81	12.03	19.67	1.24	1.42	1.41	1.40	1.51
11500	6.56	6.51	6.49	6.39	0.17	5.35	19.87	12.50	19.84	1.32	1.32	1.29	1.32	1.40
12000	6.62	6.58	6.54	6.43	0.19	5.91	19.82	13.24	19.79	1.38	1.24	1.24	1.27	1.29
12500	6.62	6.61	6.49	6.40	0.22	6.13	19.86	14.35	19.77	1.33	1.22	1.28	1.29	1.22
13000	6.68	6.57	6.45	6.40	0.27	6.17	20.29	15.52	20.08	1.30	1.32	1.39	1.39	1.27
13500	6.77	6.57	6.50	6.48	0.28	6.05	21.30	16.21	21.04	1.39	1.45	1.53	1.51	1.42
14000	6.78	6.61	6.50	6.49	0.29	5.91	22.67	16.38	22.40	1.37	1.53	1.58	1.55	1.51
14500	6.74	6.65	6.48	6.49	0.26	5.75	23.57	16.61	23.36	1.26	1.51	1.55	1.48	1.48
15000	6.75	6.67	6.56	6.57	0.19	5.89	23.33	17.29	23.22	1.28	1.41	1.46	1.40	1.43
15500	6.77	6.64	6.61	6.63	0.15	6.21	22.67	18.34	22.62	1.39	1.26	1.34	1.29	1.33
16000	6.70	6.56	6.56	6.58	0.14	6.63	22.51	19.23	22.50	1.39	1.10	1.17	1.16	1.16
16500	6.75	6.61	6.59	6.62	0.16	7.01	23.43	19.15	23.37	1.47	1.12	1.13	1.19	1.09
17000	7.01	6.83	6.81	6.84	0.20	7.27	25.45	18.65	25.34	1.66	1.33	1.34	1.35	1.27
17500	7.16	6.94	6.93	6.97	0.24	7.26	28.37	18.52	28.24	1.66	1.47	1.49	1.46	1.42
18000	7.02	6.85	6.81	6.85	0.21	7.32	31.00	18.97	31.00	1.44	1.48	1.54	1.46	1.46
18500	6.84	6.70	6.66	6.67	0.19	7.49	30.76	19.89	30.74	1.25	1.41	1.51	1.41	1.42
19000	6.79	6.64	6.64	6.64	0.15	7.63	29.33	20.80	29.26	1.28	1.33	1.41	1.32	1.33
19500	6.79	6.67	6.67	6.67	0.12	7.86	29.14	20.94	29.03	1.28	1.19	1.26	1.17	1.18
20000	6.88	6.80	6.76	6.76	0.11	8.11	30.87	20.42	30.69	1.34	1.01	1.07	1.01	1.02
20500	7.06	6.96	6.93	6.95	0.13	8.35	34.62	20.10	34.57	1.53	1.17	1.16	1.16	1.18
21000	7.14	6.95	7.00	7.03	0.19	8.56	42.83	20.26	43.16	1.58	1.34	1.33	1.28	1.34
21500	7.07	6.82	6.92	6.95	0.25	8.80	44.81	20.90	45.27	1.41	1.45	1.43	1.35	1.44
22000	6.99	6.79	6.84	6.88	0.20	9.34	37.59	21.78	37.55	1.20	1.49	1.48	1.38	1.48
22500	6.99	6.84	6.84	6.88	0.14	9.49	35.32	22.54	35.10	1.20	1.50	1.49	1.40	1.51
23000	7.01	6.87	6.87	6.92	0.14	9.49	34.92	22.79	34.81	1.27	1.49	1.42	1.39	1.50
23500	6.96	6.83	6.87	6.90	0.13	9.85	35.66	22.56	35.66	1.21	1.39	1.34	1.30	1.42
24000	6.86	6.79	6.86	6.85	0.08	10.25	37.41	22.11	37.58	1.07	1.24	1.21	1.20	1.31
24500	6.84	6.81	6.90	6.85	0.09	10.56	38.06	21.73	38.40	1.10	1.15	1.14	1.12	1.21
25000	6.85	6.83	6.96	6.87	0.13	10.75	36.20	21.56	36.23	1.20	1.09	1.11	1.11	1.13
25500	6.89	6.85	7.01	6.88	0.16	11.05	33.97	21.77	33.87	1.20	1.08	1.12	1.13	1.06
26000	6.91	6.87	7.02	6.87	0.16	11.26	32.73	22.01	32.81	1.10	1.12	1.15	1.16	1.04
26500	6.95	6.89	7.02	6.89	0.14	11.31	33.03	21.96	33.11	1.06	1.17	1.20	1.18	1.11
27000	6.98	6.89	7.03	6.93	0.15	11.42	35.24	21.21	35.50	1.16	1.18	1.20	1.18	1.18
27500	6.97	6.87	7.04	6.94	0.17	11.59	39.47	20.22	39.99	1.21	1.14	1.12	1.11	1.17
28000	7.08	7.00	7.19	7.09	0.19	11.91	38.49	19.42	38.75	1.38	1.19	1.11	1.09	1.14
28500	7.36	7.32	7.51	7.38	0.20	12.55	33.08	19.22	33.13	1.64	1.31	1.26	1.20	1.20
29000	7.59	7.59	7.77	7.57	0.20	12.92	30.40	19.55	30.52	1.73	1.43	1.43	1.35	1.32
29500	7.57	7.55	7.72	7.50	0.22	13.33	29.12	20.21	29.13	1.55	1.55	1.60	1.48	1.42
30000	7.44	7.33	7.51	7.33	0.18	13.48	28.71	20.79	28.79	1.28	1.61	1.71	1.58	1.49
30500	7.44	7.22	7.42	7.28	0.23	13.30	28.85	20.90	28.76	1.26	1.71	1.79	1.66	1.57
31000	7.46	7.23	7.40	7.32	0.24	13.27	28.28	20.59	28.28	1.32	1.65	1.73	1.62	1.57
31500	7.46	7.22	7.42	7.33	0.24	13.14	26.31	20.67	26.35	1.21	1.52	1.59	1.52	1.49
32000	7.50	7.22	7.58	7.40	0.36	13.32	24.14	21.52	24.27	1.18	1.38	1.41	1.38	1.37

⁽¹⁾Total Loss = Insertion Loss + 6dB Splitter Loss



4 Way-0° Power Splitter/Combiner

EP4KA+

Typical Performance Data

TEST CONDITIONS: Input Power = -10dBm @Temperature = -55°C

FREQ. (MHz)	TOTAL LOSS ⁽¹⁾ (dB)				AMP. UNBAL. (dB)	PHASE UNBAL. (deg.)	ISOLATION (dB)			VSWR (:1)				
	S-1	S-2	S-3	S-4			1-2	2-3	3-4	S	1	2	3	4
	10700	6.29	6.44	6.04			6.01	0.44	4.66	19.65	11.51	19.06	1.26	1.50
10800	6.28	6.44	6.04	6.00	0.44	4.49	19.76	11.58	19.19	1.26	1.49	1.47	1.45	1.58
11000	6.28	6.41	6.07	6.00	0.41	4.55	19.91	11.72	19.39	1.25	1.45	1.44	1.43	1.56
11500	6.31	6.37	6.18	6.05	0.32	4.94	20.03	12.13	19.59	1.32	1.34	1.31	1.35	1.45
12000	6.38	6.43	6.25	6.11	0.31	5.48	19.93	12.79	19.48	1.41	1.25	1.24	1.27	1.31
12500	6.38	6.46	6.20	6.08	0.38	5.69	19.90	13.86	19.39	1.37	1.21	1.25	1.28	1.21
13000	6.39	6.41	6.12	6.04	0.37	5.69	20.25	15.11	19.63	1.31	1.30	1.36	1.37	1.26
13500	6.47	6.40	6.17	6.11	0.36	5.55	21.22	15.90	20.52	1.41	1.45	1.52	1.52	1.41
14000	6.51	6.44	6.17	6.13	0.38	5.73	22.65	16.05	21.91	1.43	1.54	1.60	1.59	1.53
14500	6.46	6.47	6.13	6.11	0.36	5.76	23.74	16.17	23.07	1.29	1.53	1.58	1.53	1.53
15000	6.44	6.49	6.19	6.16	0.34	5.51	23.56	16.79	22.99	1.27	1.44	1.49	1.43	1.46
15500	6.45	6.45	6.24	6.21	0.24	5.61	22.78	17.85	22.28	1.40	1.29	1.36	1.32	1.36
16000	6.38	6.34	6.19	6.16	0.22	6.24	22.46	18.85	21.99	1.42	1.12	1.19	1.17	1.19
16500	6.41	6.37	6.18	6.17	0.23	6.81	23.23	18.88	22.69	1.47	1.10	1.11	1.17	1.07
17000	6.65	6.61	6.40	6.38	0.27	7.02	25.17	18.31	24.57	1.69	1.32	1.32	1.35	1.26
17500	6.83	6.75	6.53	6.53	0.30	7.26	28.12	18.08	27.50	1.74	1.47	1.49	1.48	1.43
18000	6.69	6.64	6.42	6.41	0.28	7.60	31.01	18.44	30.42	1.53	1.49	1.55	1.49	1.48
18500	6.48	6.46	6.23	6.21	0.27	7.84	31.11	19.31	30.52	1.29	1.42	1.53	1.44	1.44
19000	6.41	6.40	6.19	6.16	0.26	8.00	29.52	20.29	28.97	1.28	1.35	1.45	1.35	1.36
19500	6.40	6.42	6.22	6.17	0.24	8.33	29.01	20.57	28.45	1.30	1.21	1.29	1.21	1.22
20000	6.46	6.52	6.28	6.24	0.28	8.46	30.38	20.07	29.75	1.33	1.04	1.09	1.03	1.04
20500	6.62	6.68	6.44	6.41	0.28	8.28	33.68	19.64	33.08	1.54	1.15	1.14	1.14	1.16
21000	6.73	6.72	6.54	6.52	0.21	8.29	41.06	19.67	40.35	1.66	1.32	1.32	1.28	1.34
21500	6.67	6.58	6.46	6.45	0.22	8.96	48.17	20.23	48.81	1.50	1.45	1.44	1.37	1.45
22000	6.57	6.51	6.35	6.35	0.22	9.69	38.03	21.12	37.75	1.25	1.48	1.50	1.41	1.51
22500	6.54	6.55	6.34	6.33	0.22	9.96	35.22	22.00	34.65	1.21	1.51	1.52	1.43	1.54
23000	6.55	6.59	6.36	6.36	0.24	9.84	34.59	22.38	34.04	1.30	1.51	1.46	1.43	1.54
23500	6.50	6.55	6.35	6.34	0.22	10.10	35.42	22.15	34.94	1.25	1.42	1.38	1.35	1.47
24000	6.38	6.48	6.32	6.28	0.20	10.60	37.46	21.65	37.00	1.10	1.26	1.24	1.24	1.36
24500	6.34	6.49	6.33	6.25	0.24	10.94	38.49	21.22	38.17	1.07	1.17	1.15	1.14	1.25
25000	6.34	6.51	6.39	6.26	0.26	11.12	36.43	21.02	36.01	1.19	1.09	1.11	1.11	1.16
25500	6.36	6.52	6.43	6.26	0.26	11.26	33.96	21.21	33.60	1.21	1.07	1.12	1.12	1.07
26000	6.38	6.52	6.44	6.24	0.27	11.45	32.60	21.48	32.33	1.12	1.10	1.14	1.16	1.03
26500	6.40	6.53	6.43	6.25	0.29	11.48	32.73	21.54	32.33	1.04	1.16	1.19	1.19	1.10
27000	6.41	6.53	6.43	6.27	0.26	11.49	34.79	20.87	34.36	1.15	1.19	1.20	1.20	1.19
27500	6.39	6.49	6.41	6.27	0.22	11.70	39.21	19.86	38.69	1.21	1.16	1.14	1.14	1.20
28000	6.46	6.58	6.51	6.37	0.21	12.17	40.29	18.95	40.21	1.34	1.16	1.10	1.08	1.15
28500	6.72	6.90	6.83	6.66	0.24	12.76	34.00	18.60	33.68	1.65	1.27	1.24	1.18	1.19
29000	6.99	7.21	7.14	6.90	0.32	12.90	30.88	18.82	30.54	1.84	1.40	1.41	1.34	1.31
29500	6.99	7.20	7.12	6.85	0.35	12.73	29.36	19.44	28.85	1.71	1.54	1.57	1.49	1.43
30000	6.84	6.97	6.89	6.66	0.31	12.58	28.81	20.04	28.29	1.40	1.59	1.69	1.59	1.51
30500	6.81	6.82	6.77	6.58	0.25	12.62	28.99	20.26	28.27	1.27	1.70	1.78	1.69	1.60
31000	6.84	6.83	6.75	6.61	0.23	12.94	28.66	19.90	28.20	1.38	1.68	1.74	1.69	1.62
31500	6.81	6.79	6.73	6.59	0.22	13.09	26.74	19.78	26.37	1.31	1.56	1.62	1.58	1.55
32000	6.78	6.74	6.78	6.58	0.20	13.15	24.33	20.28	24.01	1.18	1.42	1.42	1.42	1.41

⁽¹⁾Total Loss = Insertion Loss + 6dB Splitter Loss



4 Way-0° Power Splitter/Combiner

EP4KA+

Typical Performance Data

TEST CONDITIONS: Input Power = -10dBm @Temperature = +105°C

FREQ. (MHz)	TOTAL LOSS ⁽¹⁾ (dB)				AMP. UNBAL. (dB)	PHASE UNBAL. (deg.)	ISOLATION (dB)			VSWR (:1)				
	S-1	S-2	S-3	S-4			1-2	2-3	3-4	S	1	2	3	4
	10700	6.62	6.75	6.33			6.34	0.42	5.64	19.83	11.80	19.46	1.24	1.46
10800	6.63	6.74	6.34	6.34	0.40	5.52	19.93	11.88	19.56	1.24	1.45	1.41	1.41	1.53
11000	6.64	6.71	6.38	6.35	0.36	5.46	20.03	12.03	19.70	1.24	1.40	1.38	1.39	1.50
11500	6.68	6.71	6.50	6.43	0.28	6.04	20.06	12.55	19.84	1.32	1.30	1.27	1.32	1.40
12000	6.73	6.78	6.54	6.46	0.33	6.66	20.05	13.33	19.82	1.36	1.23	1.25	1.28	1.28
12500	6.74	6.81	6.50	6.44	0.38	6.51	20.18	14.46	19.85	1.31	1.23	1.30	1.32	1.23
13000	6.81	6.79	6.48	6.46	0.35	6.27	20.67	15.58	20.22	1.30	1.33	1.31	1.41	1.28
13500	6.90	6.80	6.53	6.54	0.37	6.80	21.73	16.20	21.21	1.38	1.45	1.52	1.53	1.42
14000	6.91	6.85	6.52	6.55	0.39	7.32	23.04	16.38	22.53	1.35	1.52	1.56	1.56	1.50
14500	6.88	6.88	6.52	6.55	0.36	7.23	23.76	16.67	23.37	1.25	1.49	1.52	1.48	1.48
15000	6.90	6.91	6.61	6.64	0.30	7.19	23.47	17.41	23.20	1.28	1.39	1.44	1.39	1.42
15500	6.91	6.89	6.66	6.70	0.25	7.65	22.92	18.46	22.67	1.39	1.25	1.31	1.28	1.31
16000	6.85	6.83	6.61	6.66	0.23	8.21	22.91	19.24	22.65	1.39	1.08	1.15	1.15	1.15
16500	6.92	6.91	6.66	6.72	0.26	8.54	23.99	19.07	23.62	1.48	1.13	1.15	1.21	1.10
17000	7.18	7.11	6.88	6.94	0.30	8.83	26.12	18.61	25.66	1.65	1.33	1.34	1.37	1.28
17500	7.30	7.21	6.97	7.05	0.34	9.34	29.02	18.57	28.55	1.62	1.46	1.47	1.47	1.42
18000	7.16	7.12	6.85	6.92	0.31	9.79	31.26	19.09	31.05	1.40	1.46	1.52	1.46	1.45
18500	7.00	6.99	6.72	6.77	0.28	9.95	30.74	20.03	30.60	1.24	1.39	1.48	1.41	1.41
19000	6.96	6.94	6.71	6.75	0.25	10.21	29.56	20.86	29.30	1.28	1.31	1.38	1.31	1.31
19500	6.96	6.98	6.74	6.78	0.24	10.67	29.73	20.89	29.32	1.28	1.16	1.22	1.15	1.17
20000	7.07	7.14	6.85	6.89	0.29	10.74	31.89	20.36	31.26	1.35	1.00	1.06	1.02	1.02
20500	7.24	7.28	7.02	7.07	0.26	10.53	36.13	20.15	35.45	1.53	1.18	1.17	1.18	1.20
21000	7.30	7.24	7.06	7.14	0.23	10.86	44.95	20.40	44.57	1.54	1.34	1.32	1.30	1.34
21500	7.22	7.13	6.98	7.06	0.24	11.77	42.91	21.09	43.69	1.36	1.43	1.42	1.36	1.43
22000	7.17	7.13	6.92	7.00	0.25	12.48	37.56	21.95	37.45	1.18	1.47	1.46	1.39	1.47
22500	7.17	7.19	6.94	7.02	0.25	12.62	35.83	22.58	35.37	1.19	1.47	1.46	1.40	1.49
23000	7.19	7.21	6.97	7.05	0.24	12.71	35.68	22.73	35.23	1.24	1.46	1.38	1.37	1.48
23500	7.15	7.18	6.97	7.04	0.21	13.20	36.33	22.50	36.02	1.17	1.36	1.30	1.28	1.39
24000	7.06	7.16	6.98	7.01	0.18	13.66	37.57	22.10	37.56	1.05	1.21	1.18	1.18	1.29
24500	7.05	7.19	7.03	7.01	0.17	13.98	37.69	21.78	37.99	1.11	1.14	1.13	1.11	1.20
25000	7.07	7.22	7.09	7.04	0.18	14.26	36.15	21.64	36.08	1.19	1.09	1.11	1.11	1.12
25500	7.11	7.25	7.15	7.06	0.20	14.63	34.33	21.82	34.00	1.19	1.09	1.13	1.14	1.06
26000	7.14	7.28	7.16	7.05	0.23	14.74	33.27	22.00	33.06	1.10	1.11	1.15	1.17	1.05
26500	7.18	7.31	7.17	7.08	0.23	14.77	33.70	21.88	33.44	1.06	1.16	1.20	1.19	1.11
27000	7.21	7.31	7.18	7.13	0.19	14.94	35.94	21.12	35.87	1.15	1.16	1.19	1.18	1.17
27500	7.22	7.31	7.21	7.15	0.16	15.25	39.45	20.18	39.72	1.21	1.13	1.10	1.10	1.16
28000	7.34	7.47	7.38	7.31	0.16	15.80	37.48	19.46	37.77	1.39	1.18	1.11	1.10	1.13
28500	7.63	7.79	7.71	7.60	0.19	16.45	32.72	19.34	32.73	1.64	1.31	1.27	1.22	1.21
29000	7.84	8.05	7.94	7.78	0.27	16.61	30.33	19.74	30.32	1.70	1.42	1.43	1.37	1.32
29500	7.80	7.98	7.86	7.69	0.29	16.40	29.20	20.44	29.05	1.50	1.55	1.60	1.52	1.42
30000	7.69	7.77	7.66	7.53	0.24	16.32	28.90	21.02	28.76	1.22	1.61	1.71	1.62	1.50
30500	7.71	7.68	7.60	7.51	0.20	16.55	28.99	21.09	28.68	1.24	1.71	1.79	1.70	1.58
31000	7.73	7.70	7.59	7.54	0.18	17.04	28.18	20.84	28.10	1.28	1.63	1.70	1.64	1.57
31500	7.74	7.72	7.64	7.58	0.16	17.26	26.22	21.09	26.17	1.16	1.51	1.56	1.52	1.49
32000	7.84	7.80	7.89	7.71	0.18	17.47	24.26	22.17	24.28	1.20	1.38	1.40	1.38	1.38

⁽¹⁾Total Loss = Insertion Loss + 6dB Splitter Loss



Typical Performance Curves

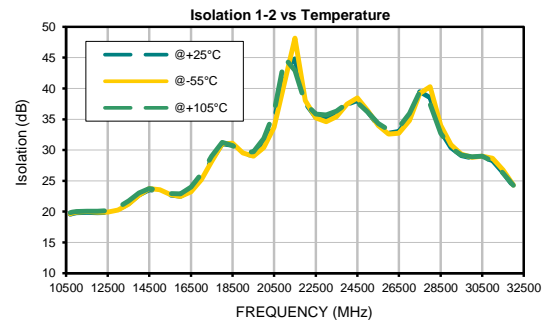
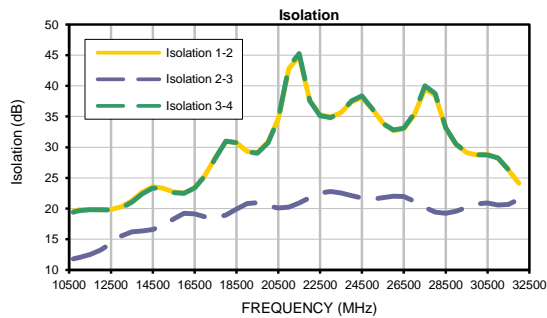
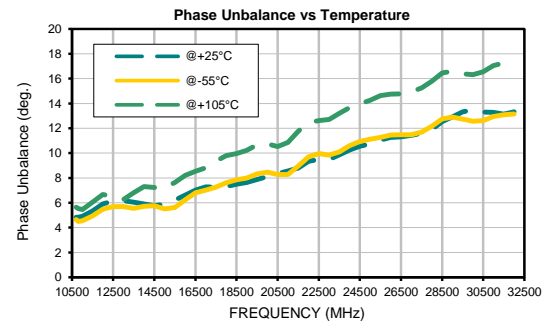
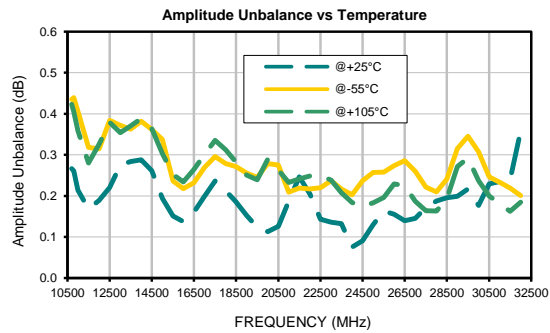
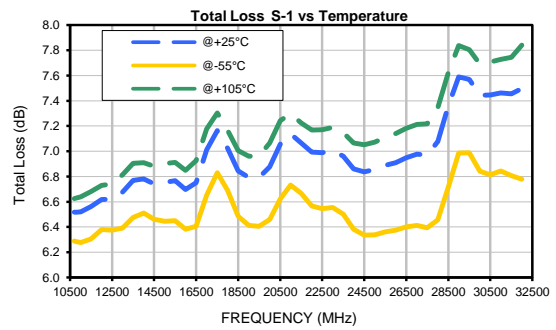
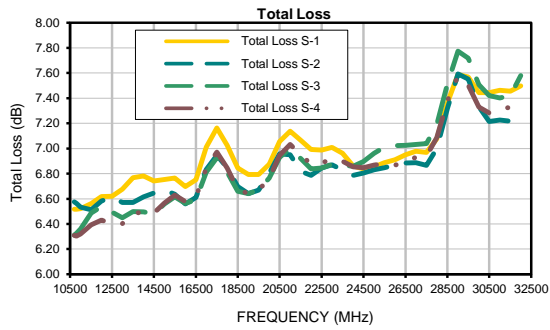

Typical Performance Curves

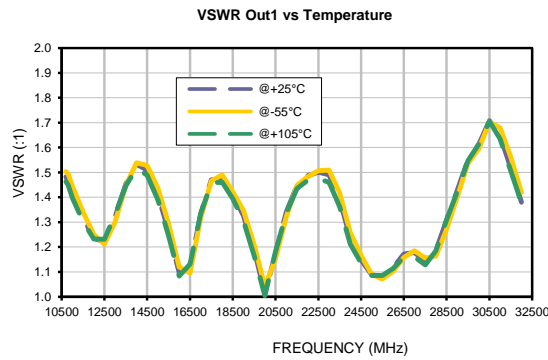
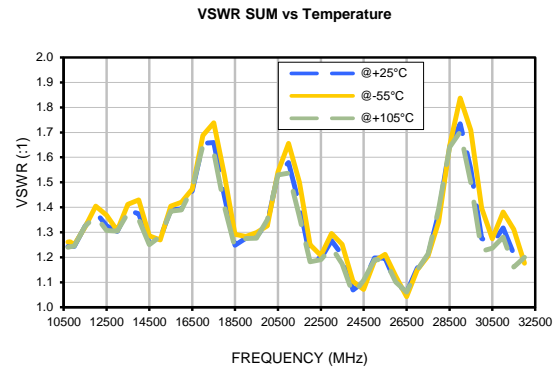
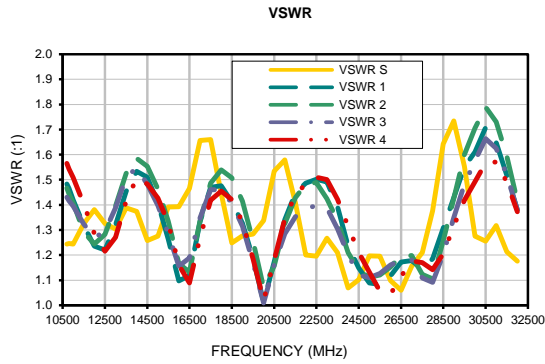

Outline Dimensions

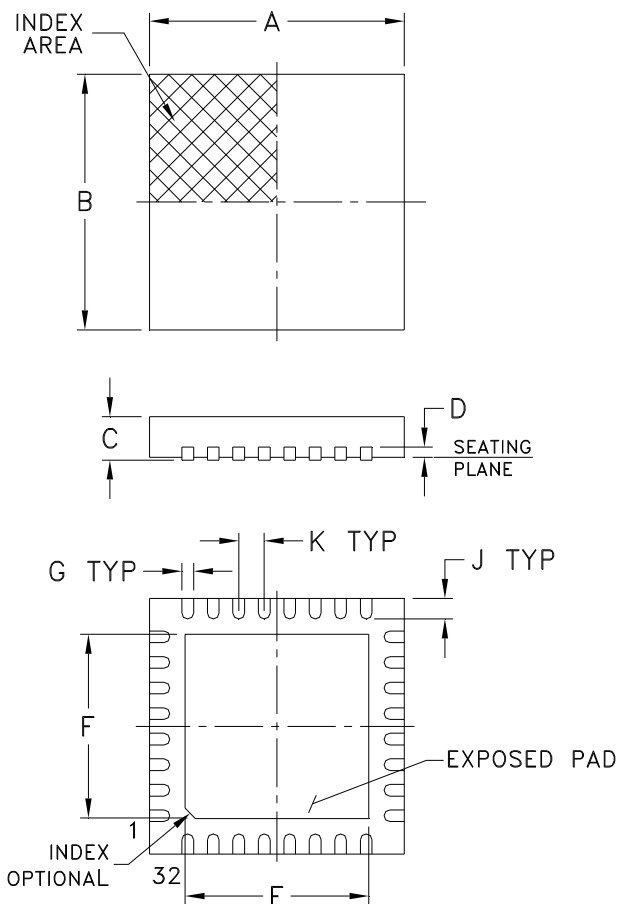

PCB Land Pattern

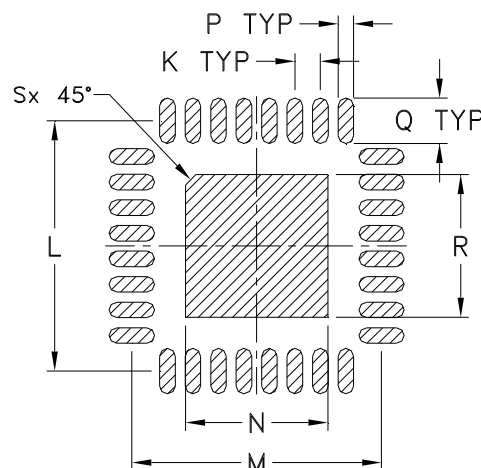

Suggested Layout,
Tolerance to be within $\pm .002$

CASE #	A	B	C MAX	C MIN	D	E	F	G	H	J
DG1677-2	.197 (5.00)	.197 (5.00)	.039 (1.00)	.031 (0.80)	.008 (0.20)	.142 (3.60)	.142 (3.60)	.009 (0.23)	- -	.016 (0.40)
CASE #	K	L	M	N	P	Q	R	S	WT. GRAM	
DG1677-2	.020 (0.50)	.193 (4.90)	.193 (4.90)	.110 (2.79)	.012 (0.30)	.035 (0.89)	.110 (2.79)	.008 (0.20)	.05	

Dimensions are in inches (mm). Tolerances: 2 Pl. $\pm .01$; 3 Pl. $\pm .005$

Notes:

- Case material: Plastic.
- Termination finish:

For RoHS Case Styles: Tin-Silver alloy plate over Nickel barrier transitioning to Matte-Tin.
All models, (+) suffix. See Data sheet.

For RoHS-5 Case Styles: Tin-Lead plate. All models, no (+) suffix.

Tape & Reel Packaging TR-F68

DEVICE ORIENTATION IN T&R

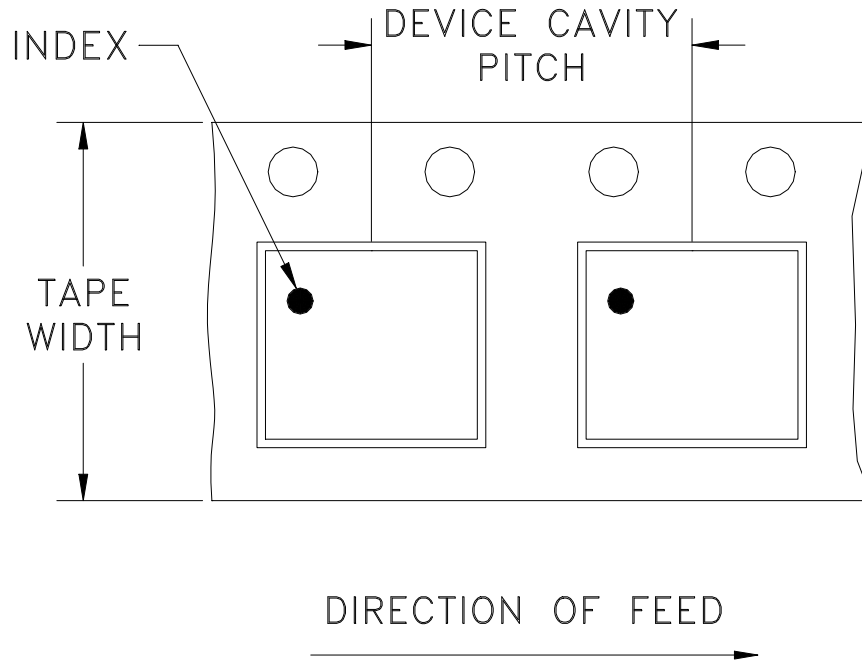

Tape Width, mm	Device Cavity Pitch, mm	Reel Size, inches	Devices per Reel see note	
12	8	7	Small quantity standard	20
				50
				100
				200
				500
		7	Standard	1000
		13	Standard	2000
				3000
				4000

Mini-Circuits carrier tape materials provide protection from ESD (Electro-Static Discharge) during handling and transportation. Tapes are static dissipative and comply with industry standards EIA-481/EIA-541.

Go to: www.minicircuits.com/pages/pdfs/tape.pdf



INTERNET <http://www.minicircuits.com>

P.O. Box 350166, Brooklyn, New York 11235-0003 (718) 934-4500 Fax (718) 332-4661

Distribution Centers NORTH AMERICA 800-654-7949 • 417-335-5935 • Fax 417-335-5945 • EUROPE 44-1252-832600 • Fax 44-1252-837010

Mini-Circuits ISO 9001 & ISO 14001 Certified

THIRD ANGLE PROJECTION

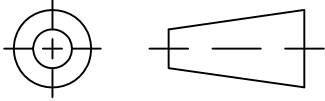

REVISIONS

REV OR	ECN No.	DESCRIPTION	DATE	DR	AUTH
	M175739	NEW RELEASE	09/10/19	ITG	CM

SUGGESTED MOUNTING CONFIGURATION
FOR DG1677-2 CASE STYLE

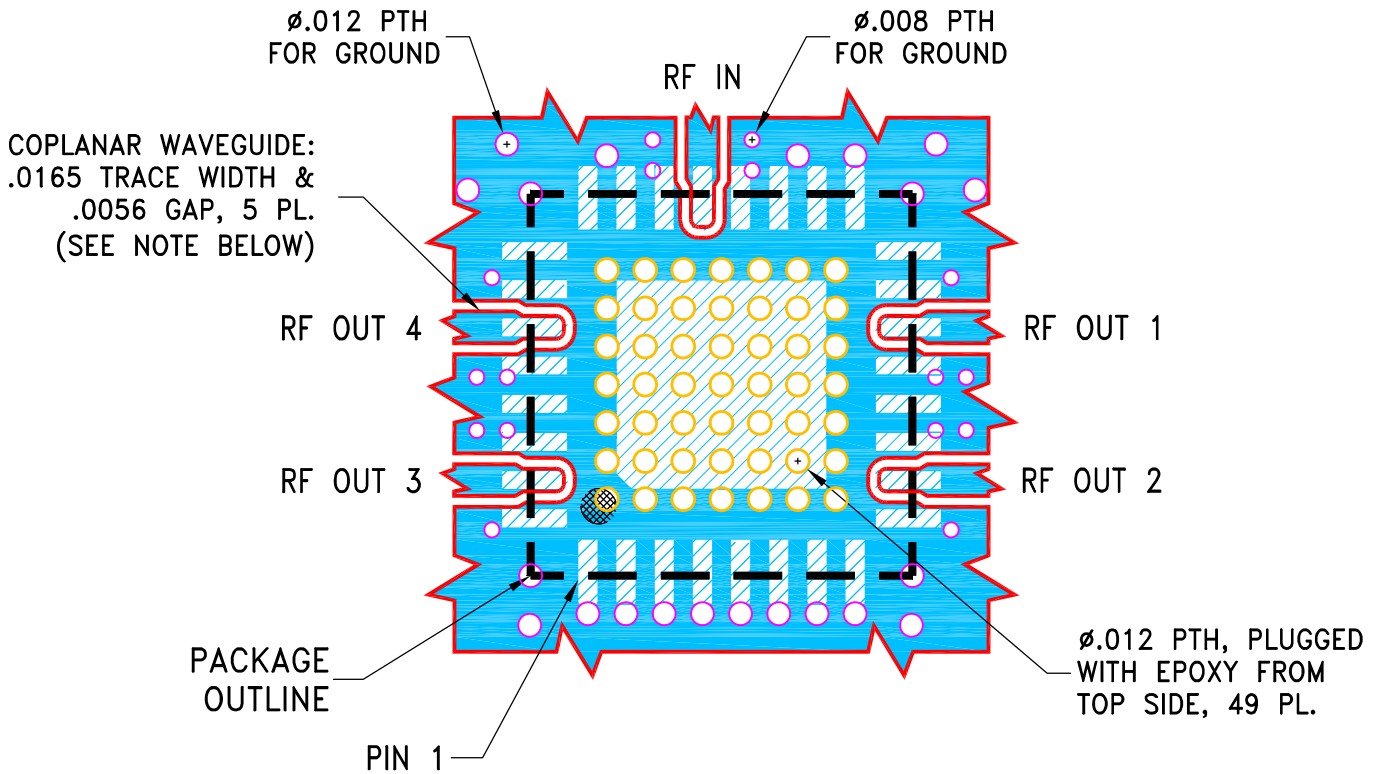

NOTES:

- TRACE WIDTH & GAP ARE SHOWN FOR ROGERS R04350B WITH DIELECTRIC THICKNESS .010"±.001"; COPPER: 1/2 OZ. EACH SIDE. FOR OTHER MATERIALS TRACE WIDTH & GAP MAY NEED TO BE MODIFIED.
- BOTTOM SIDE OF THE PCB IS CONTINUOUS GROUND PLANE.



DENOTES PCB COPPER LAYOUT WITH SMOBC (SOLDER MASK OVER BARE COPPER).

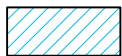

DENOTES COPPER LAND PATTERN FREE OF SOLDER MASK.

UNLESS OTHERWISE SPECIFIED	INITIALS		DATE
DIMENSIONS ARE IN INCHES TOLERANCES ON: 2 PL DECIMALS ± 3 PL DECIMALS ± .005 ANGLES ± FRACTIONS ±	DRAWN	ITG	08/28/19
	CHECKED	GF	09/03/19
	APPROVED	CM	09/10/19



Mini-Circuits®

13 Neptune Avenue
Brooklyn NY 11235

PL, DG1677-2, TB-EP4RKU+/EP4KA+

SIZE	CODE IDENT	DRAWING NO:	REV:
A	15542	98-PL-649	OR
FILE:	98PL649	SCALE: 10:1	SHEET: 1 OF 1

Mini-Circuits®
THIS DOCUMENT AND ITS CONTENTS ARE THE PROPERTY OF MINI-CIRCUITS. EXCEPT FOR USE EXPRESSLY GRANTED, IN WRITING, TO ITS VENDORS, VENDEE AND THE UNITED STATES GOVERNMENT, MINI-CIRCUITS RESERVES ALL PROPRIETARY DESIGN, USE, MANUFACTURING AND REPRODUCTION RIGHTS THERETO. THESE CONTENTS SHALL NOT BE USED, DUPLICATED OR DISCLOSED TO ANY OUTSIDE PARTY, IN WHOLE OR IN PART, WITHOUT WRITTEN PERMISSION OF MINI-CIRCUITS.

Evaluation Board and Circuit

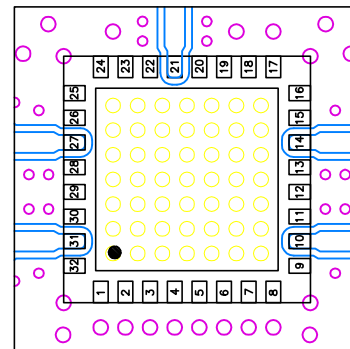
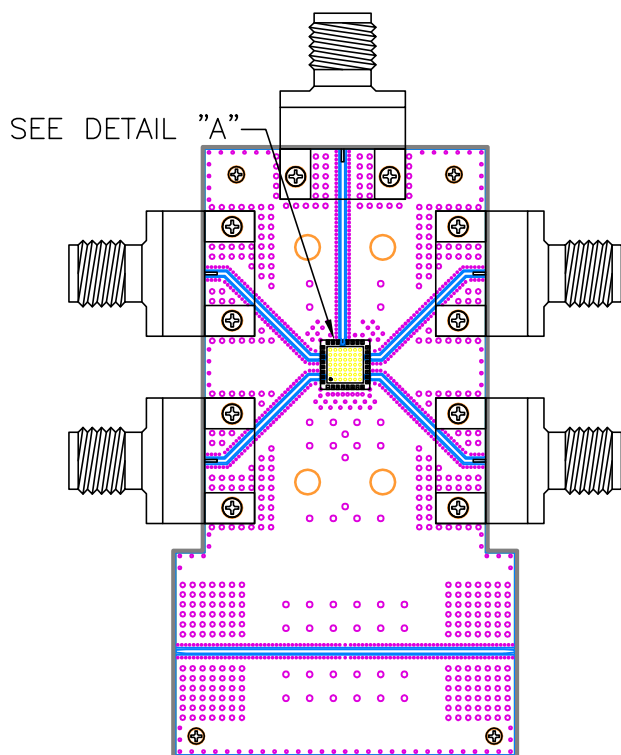

DETAIL "A"
(SCALE 5:1)

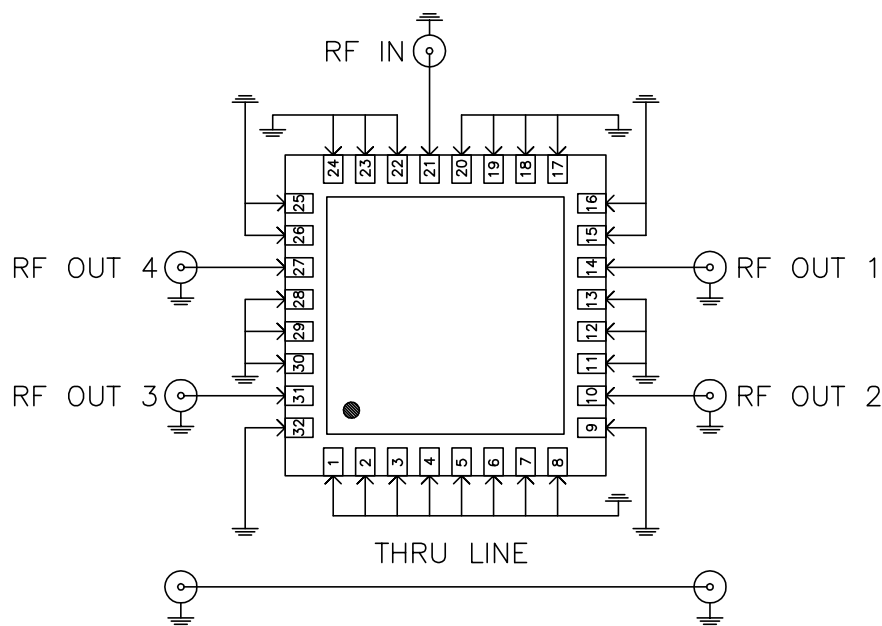

SCHEMATIC DIAGRAM
(SCALE 5:1)

Notes:

1. 2.92mm Female Connectors.
2. PCB Material: Roger R04350B or equivalent,
Dielectric constant=3.5, Thickness=0.010 inch

 **Mini-Circuits®**

Evaluation Board and Circuit

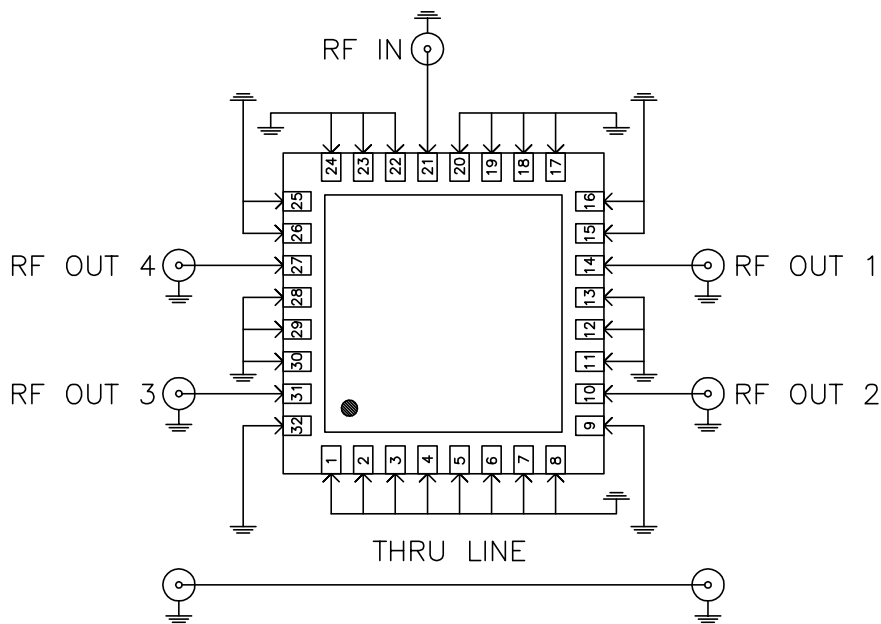
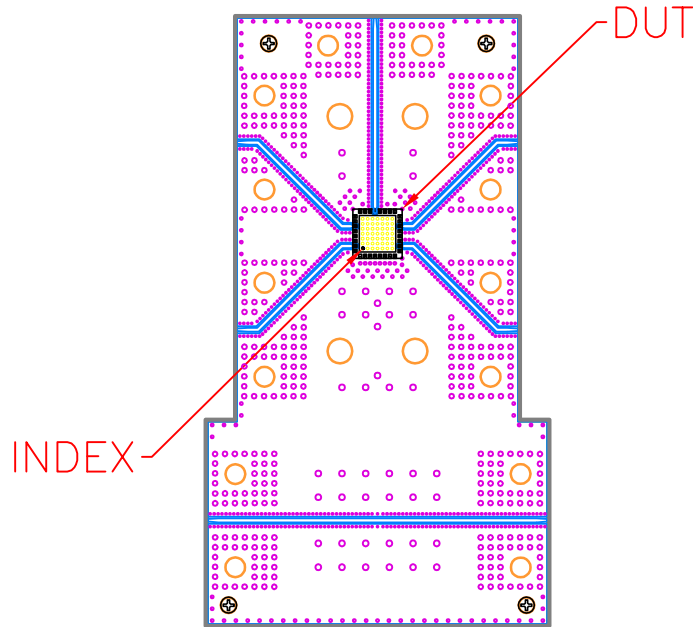

SCHEMATIC DIAGRAM
(SCALE 5:1)

Notes:

1. PCB Material: Roger R04350B or equivalent,
Dielectric constant=3.5, Thickness=0.010 inch

 **Mini-Circuits®**

All Mini-Circuits products are manufactured under exacting quality assurance and control standards, and are capable of meeting published specifications after being subjected to any or all of the following physical and environmental test.

Specification	Test/Inspection Condition	Reference/Spec
Operating Temperature	-40° to 85°C or -45° to 85°C Ambient Environment	Individual Model Data Sheet
Storage Temperature	-55° to 100° C or -65° to 150° Ambient Environment	Individual Model Data Sheet
Thermal Shock	-55° to 100°C, 100 cycles	MIL-STD-202, Method 107, Condition A-3, except +100°C
Mechanical Shock	1.5Kg, 0.5 ms, 5 shock pulses, Y1 direction only	MIL-STD-883, Method 2002, Condition B, except Y1 direction only
Vibration (Variable Frequency)	50g peak	MIL-STD-883, Method 2007, Condition B
Autoclave	15 psig, 100% RH, 121°C, 96 hours	JESD22-A102, Condition C
HAST	130°C, 85% RH, 96 hours	JESD22-A110
Solderability	10X Magnification	J-STD-002, Para 4.2.5, Test S, 95% Coverage
Solder Reflow Heat	Sn-Pb Eutetic Process: 240°C peak Pb-Free Process: 260°C peak	J-STD-020, Table 4-1, 4-2 and 5-2; Figure 5-1
Moisture Sensitivity: Level 1	Bake at 125°C for 24 hours Soak at 85°C/85% RH for 168 hours, Reflow 3 cycles at 260°C peak	J-STD-020
Marking Resistance to Solvents	Isopropyl alcohol + mineral spirits at 25°C; terpene defluxer at 25°C; distilled water + proylene glycol monomethyl ether +	MIL-STD-202, Method 215



All Mini-Circuits products are manufactured under exacting quality assurance and control standards, and are capable of meeting published specifications after being subjected to any or all of the following physical and environmental test.

Specification	Test/Inspection Condition	Reference/Spec
	monoethanolamine at 63°C to 70°C	