



MMIC SURFACE MOUNT

Power Splitter/Combiner

EP2C+

2 Way-0° 50Ω 1800 to 12500 MHz

THE BIG DEAL

- Ultra-Wide bandwidth, 1800 to 12500 MHz
- High power handling, 1.85W as a splitter
- Low cost splitter for 5G Application
- Excellent amplitude unbalance, 0.2 dB typ.
- Good phase unbalance, 6° typ.
- High ESD level
- Small size, 4x4 mm
- Aqueous washable
- DC passing

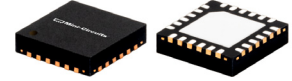

Generic photo used for illustration purposes only

CASE STYLE: DG1847

+RoHS Compliant

The +Suffix identifies RoHS Compliance. See our web site for RoHS Compliance methodologies and qualifications

APPLICATIONS

- WIMAX
- ISM
- Instrumentation
- Radar
- WLAN
- Satellite communications
- LTE

PRODUCT OVERVIEW

Mini-Circuits EP2C+ is a MMIC splitter/combiner designed for wideband operation from 1800 to 12500 MHz. This model provides excellent power ratings in a tiny device package (4x4x1 mm), with up to 1.85W power handling (as a splitter) and up to 0.4A DC current handling. Manufactured using GaAs IPD technology, it provides a high level of ESD protection and excellent reliability.

KEY FEATURES

Feature	Advantages
Wideband, 1800 to 12500 MHz	One power splitter can be used in many applications, saving component count. Also ideal for wideband applications such as military and instrumentation.
Excellent power handling 1.8W as a splitter 0.85W internal dissipation as a combiner	In power combiner applications, half the power is dissipated internally. EP2C+ is designed to handle 0.85W internal dissipation as a combiner allowing reliable operation without excessive temperature rise. Similar splitters implemented as Wilkinson splitters on PCB require big resistors and additional heat sinking. As a splitter, EP2C+ can handle up to 1.85W in a very small package.
DC Passing up to 0.4A	DC current passing is helpful in applications where both RF & DC need to pass through the DUT, such as antenna mounted hardware.
Small size 4 x 4mm QFN package	Tiny footprint saves space in dense layouts while providing low inductance, repeatable transitions, and excellent thermal contact to the PCB.





ELECTRICAL SPECIFICATIONS AT 25°C

Parameter	Frequency (MHz)	Min.	Typ.	Max.	Unit
Frequency Range		1800		12500	GHz
Insertion Loss above 3.0 dB	1800-3800	—	0.8	1.1	dB
	3800-8500	—	1.1	1.4	
	8500-12500	—	1.8	2.1	
Isolation	1800-3800	7.0	10.0	—	dB
	3800-8500	13.0	16.0	—	
	8500-12500	14.0	17.0	—	
Phase Unbalance	1800-3800	—	3.0	6.0	Degree
	3800-8500	—	6.0	10.0	
	8500-12500	—	11.0	—	
Amplitude Unbalance	1800-3800	—	0.1	0.2	dB
	3800-8500	—	0.2	0.4	
	8500-12500	—	0.7	0.9	
VSWR (Port S)	1800-3800	—	1.5	—	:1
	3800-8500	—	1.3	—	
	8500-12500	—	1.4	—	
VSWR (Port 1-2)	1800-3800	—	1.2	—	:1
	3800-8500	—	1.3	—	
	8500-12500	—	1.6	—	

MAXIMUM RATINGS

Parameter	Ratings
Operating Temperature	-40°C to 85°C
Storage Temperature	-65°C to 150°C
Power Input (as a splitter)	1.85W max.
Internal Dissipation	0.85W max.
DC Current	0.4 A max.

Permanent damage may occur if any of these limits are exceeded.

PAD CONNECTIONS

Function	Pad Number
SUM PORT	3
PORT 1	19
PORT 2	12
NOT USED, GROUND EXTERNALLY	1, 2, 4-11, 13-18, 20-24, Paddle

PRODUCT MARKING

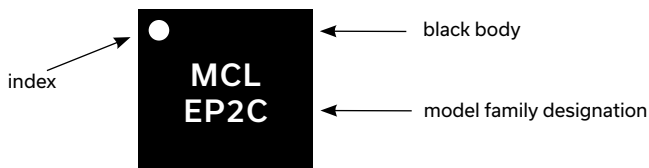

Marking may contain other features or characters for internal lot control

SIMPLIFIED ELECTRICAL SCHEMATIC

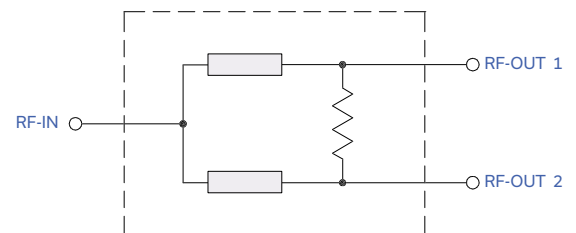



ADDITIONAL DETAILED TECHNICAL INFORMATION IS AVAILABLE ON OUR DASH BOARD. TO ACCESS [CLICK HERE](#)

Performance Data	Data Table Swept Graphs S-Parameter (S3P Files) Data Set (.zip file)
Case Style	DG1847 Plastic package, exposed paddle; lead finish: Matte Tin
Tape & Reel Standard quantities available on reel	F68 7" reels with 20, 50, 100, 200, 500, 1000 devices 13" reels with 2000, 3000, 4000 devices
Suggested Layout for PCB Design	PL-442
Evaluation Board	TB-811+
Environmental Ratings	ENV82

ESD RATING

Human Body Model (HBM): Class 2 (1800 to <4000 V) in accordance with ANSI/ESD STM 5.1 - 2001

Machine Model (MM): Class M3 (200 to <400 V) in accordance with ANSI/ESD STM 5.2 - 1999

MSL TEST FLOW CHART

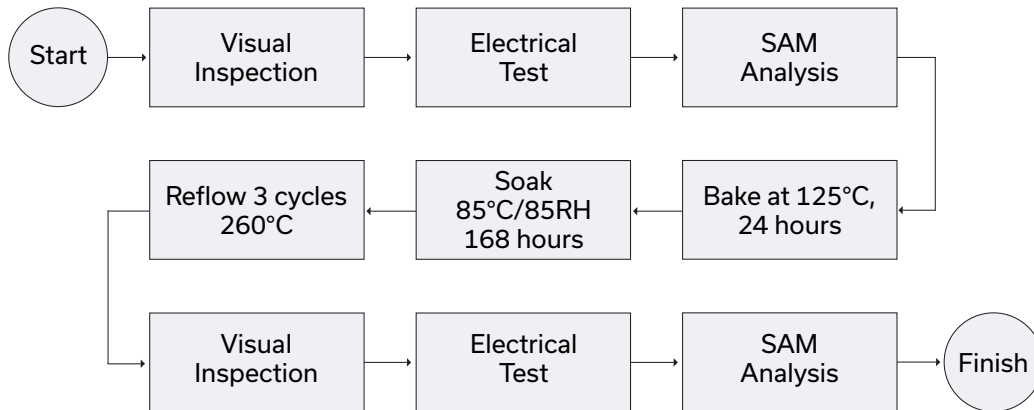

- NOTES**
- A. Performance and quality attributes and conditions not expressly stated in this specification document are intended to be excluded and do not form a part of this specification document.
 - B. Electrical specifications and performance data contained in this specification document are based on Mini-Circuit's applicable established test performance criteria and measurement instructions.
 - C. The parts covered by this specification document are subject to Mini-Circuits standard limited warranty and terms and conditions (collectively, "Standard Terms"); Purchasers of this part are entitled to the rights and benefits contained therein. For a full statement of the standard. Terms and the exclusive rights and remedies thereunder, please visit Mini-Circuits' website at www.minicircuits.com/MCLStore/terms.jsp

2 Way-0° Power Splitter/Combiner

EP2C+

Typical Performance Data

TEST CONDITIONS: INPUT POWER = -10 dBm @Temperature = +25°C

FREQ. (MHz)	TOTAL LOSS ⁽¹⁾ (dB)		AMP. UNBAL. (dB)	PHASE UNBAL. (deg.)	ISOLATION (dB)	VSWR (:1)		
	S-1	S-2				S	1	2
500.0	3.72	3.73	0.01	0.28	5.53	1.85	1.62	1.61
1000.0	3.69	3.70	0.02	0.55	8.11	1.76	1.45	1.45
1500.0	3.64	3.66	0.03	0.79	10.65	1.68	1.38	1.39
1800.0	3.62	3.65	0.03	0.94	12.01	1.65	1.36	1.37
2000.0	3.61	3.64	0.03	1.02	12.84	1.62	1.34	1.36
2500.0	3.57	3.60	0.03	1.24	14.61	1.54	1.28	1.30
3000.0	3.50	3.53	0.03	1.45	16.28	1.41	1.17	1.18
3500.0	3.46	3.48	0.02	1.67	18.44	1.25	1.03	1.03
3800.0	3.46	3.48	0.02	1.84	20.20	1.25	1.06	1.07
4000.0	3.48	3.50	0.02	1.92	21.64	1.23	1.12	1.14
4200.0	3.51	3.53	0.02	2.04	23.29	1.27	1.18	1.21
4400.0	3.55	3.57	0.02	2.13	25.25	1.32	1.24	1.27
4600.0	3.59	3.61	0.02	2.23	26.86	1.38	1.29	1.33
4800.0	3.64	3.66	0.02	2.32	27.62	1.43	1.33	1.38
5000.0	3.67	3.69	0.03	2.41	27.26	1.47	1.36	1.41
5200.0	3.70	3.72	0.02	2.50	25.96	1.49	1.39	1.43
5400.0	3.71	3.73	0.03	2.58	24.70	1.49	1.39	1.44
5600.0	3.71	3.74	0.02	2.64	23.63	1.47	1.39	1.43
5800.0	3.70	3.73	0.02	2.70	22.69	1.44	1.38	1.41
6000.0	3.69	3.71	0.02	2.76	22.01	1.39	1.36	1.37
6200.0	3.67	3.69	0.02	2.84	21.69	1.34	1.33	1.34
6400.0	3.66	3.67	0.01	2.87	21.61	1.28	1.31	1.30
6600.0	3.65	3.65	0.00	2.95	21.73	1.22	1.29	1.27
6800.0	3.64	3.64	0.00	3.02	21.97	1.17	1.27	1.25
7000.0	3.65	3.64	0.01	3.11	22.52	1.13	1.26	1.23
7200.0	3.66	3.64	0.02	3.17	23.07	1.10	1.26	1.22
7400.0	3.67	3.64	0.03	3.26	23.69	1.10	1.26	1.22
7600.0	3.69	3.65	0.04	3.40	24.26	1.10	1.26	1.21
7800.0	3.70	3.66	0.04	3.48	24.75	1.09	1.26	1.22
8000.0	3.72	3.67	0.05	3.53	25.25	1.10	1.27	1.22
8500.0	3.79	3.73	0.07	3.75	27.39	1.17	1.32	1.28
9000.0	3.91	3.82	0.09	3.88	34.16	1.31	1.44	1.38
9500.0	4.01	3.88	0.13	4.13	29.06	1.40	1.54	1.43
10000.0	4.03	3.87	0.16	4.38	21.94	1.32	1.52	1.39
10500.0	4.00	3.81	0.19	4.86	19.06	1.09	1.43	1.28
11000.0	4.05	3.85	0.20	5.47	19.27	1.17	1.44	1.27
11500.0	4.15	3.96	0.19	5.88	23.16	1.36	1.50	1.34
12000.0	4.18	4.03	0.16	6.24	26.94	1.38	1.41	1.33
12500.0	4.23	4.07	0.16	6.47	19.52	1.39	1.18	1.23
13000.0	4.36	4.17	0.19	6.80	15.74	1.51	1.11	1.07
13500.0	4.50	4.28	0.22	7.45	13.99	1.61	1.33	1.20
14000.0	4.60	4.40	0.19	8.58	12.13	1.66	1.57	1.53

⁽¹⁾ Total Loss = Insertion Loss + 3dB splitter loss.



P.O. Box 350166, Brooklyn, New York 11235-0003 (718) 934-4500 • Fax (718) 332-4661 For detailed performance specs & shopping online see Mini-Circuits web site
 The Design Engineers Search Engine Provides ACTUAL Data Instantly From MINI-CIRCUITS At: www.minicircuits.com



IF/RF MICROWAVE COMPONENTS

REV. OR
 EP2C+
 2/3/2015
 Page 1 of 3

2 Way-0° Power Splitter/Combiner

EP2C+

Typical Performance Data

TEST CONDITIONS: INPUT POWER = -10 dBm @Temperature = -45 °C

FREQ. (MHz)	TOTAL LOSS ⁽¹⁾ (dB)		AMP. UNBAL. (dB)	PHASE UNBAL. (deg.)	ISOLATION (dB)	VSWR (:1)		
	S-1	S-2				S	1	2
500.0	3.67	3.67	0.01	0.31	5.39	1.90	1.65	1.64
1000.0	3.61	3.62	0.01	0.60	8.01	1.80	1.49	1.49
1500.0	3.53	3.56	0.03	0.91	10.49	1.71	1.39	1.41
1800.0	3.49	3.53	0.04	1.11	11.90	1.67	1.36	1.39
2000.0	3.46	3.49	0.02	1.14	12.83	1.62	1.35	1.36
2500.0	3.41	3.43	0.02	1.50	14.74	1.53	1.27	1.30
3000.0	3.35	3.37	0.02	1.70	16.31	1.42	1.19	1.20
3500.0	3.29	3.31	0.02	2.00	18.14	1.28	1.05	1.05
3800.0	3.27	3.29	0.02	2.20	19.60	1.24	1.05	1.05
4000.0	3.28	3.30	0.02	2.29	20.82	1.24	1.10	1.11
4200.0	3.30	3.31	0.01	2.42	22.42	1.27	1.16	1.19
4400.0	3.33	3.35	0.02	2.55	24.35	1.33	1.23	1.27
4600.0	3.37	3.39	0.02	2.69	26.10	1.40	1.29	1.33
4800.0	3.42	3.44	0.02	2.78	26.90	1.48	1.34	1.40
5000.0	3.45	3.47	0.02	2.87	26.67	1.53	1.38	1.43
5200.0	3.48	3.50	0.02	2.99	25.44	1.56	1.40	1.46
5400.0	3.47	3.50	0.03	3.09	24.61	1.55	1.41	1.47
5600.0	3.49	3.51	0.03	3.15	22.83	1.57	1.42	1.47
5800.0	3.47	3.48	0.01	3.23	21.75	1.53	1.41	1.42
6000.0	3.43	3.45	0.02	3.34	21.21	1.45	1.37	1.40
6200.0	3.40	3.41	0.01	3.37	20.80	1.38	1.35	1.34
6400.0	3.38	3.38	0.00	3.48	20.80	1.29	1.32	1.30
6600.0	3.35	3.34	0.01	3.54	21.06	1.20	1.29	1.25
6800.0	3.34	3.32	0.02	3.70	21.67	1.13	1.27	1.22
7000.0	3.33	3.31	0.02	3.84	22.71	1.10	1.27	1.24
7200.0	3.35	3.31	0.04	3.91	23.83	1.13	1.30	1.24
7400.0	3.36	3.32	0.04	4.10	24.92	1.16	1.32	1.26
7600.0	3.38	3.33	0.05	4.20	25.30	1.18	1.32	1.26
7800.0	3.38	3.32	0.06	4.34	25.13	1.17	1.32	1.24
8000.0	3.39	3.32	0.07	4.46	24.50	1.12	1.30	1.23
8500.0	3.42	3.36	0.07	4.75	25.22	1.15	1.32	1.28
9000.0	3.53	3.45	0.08	4.97	32.58	1.34	1.46	1.41
9500.0	3.59	3.49	0.11	5.10	30.21	1.43	1.54	1.45
10000.0	3.61	3.46	0.15	5.24	22.73	1.36	1.53	1.40
10500.0	3.61	3.39	0.21	5.60	19.22	1.23	1.50	1.31
11000.0	3.61	3.35	0.26	6.31	17.76	1.07	1.44	1.22
11500.0	3.74	3.48	0.26	7.04	19.68	1.41	1.59	1.31
12000.0	3.83	3.63	0.20	7.57	32.62	1.65	1.63	1.46
12500.0	3.82	3.66	0.17	7.81	19.94	1.63	1.29	1.37
13000.0	3.97	3.79	0.17	8.10	14.26	1.82	1.12	1.05
13500.0	4.12	3.91	0.21	8.52	13.39	1.98	1.39	1.25
14000.0	3.97	3.76	0.21	9.38	13.30	1.61	1.48	1.50

⁽¹⁾ Total Loss = Insertion Loss + 3dB splitter loss.



2 Way-0° Power Splitter/Combiner

EP2C+

Typical Performance Data

TEST CONDITIONS: INPUT POWER = -10 dBm @Temperature = +85 °C

FREQ. (MHz)	TOTAL LOSS ⁽¹⁾ (dB)		AMP. UNBAL. (dB)	PHASE UNBAL. (deg.)	ISOLATION (dB)	VSWR (:1)		
	S-1	S-2				S	1	2
500.0	3.74	3.76	0.02	0.23	5.60	1.82	1.58	1.58
1000.0	3.73	3.74	0.02	0.46	8.23	1.73	1.43	1.43
1500.0	3.71	3.74	0.03	0.63	10.76	1.67	1.39	1.40
1800.0	3.71	3.74	0.03	0.74	12.02	1.66	1.38	1.39
2000.0	3.70	3.73	0.03	0.82	12.76	1.64	1.36	1.37
2500.0	3.65	3.68	0.03	1.02	14.42	1.54	1.27	1.29
3000.0	3.58	3.61	0.03	1.21	16.31	1.38	1.14	1.16
3500.0	3.56	3.58	0.02	1.38	18.91	1.23	1.00	1.03
3800.0	3.58	3.60	0.02	1.52	20.90	1.21	1.08	1.09
4000.0	3.60	3.62	0.02	1.59	22.50	1.23	1.13	1.16
4200.0	3.64	3.65	0.01	1.67	24.32	1.27	1.19	1.22
4400.0	3.68	3.70	0.01	1.77	26.39	1.31	1.25	1.28
4600.0	3.72	3.74	0.02	1.83	28.08	1.35	1.30	1.33
4800.0	3.76	3.78	0.01	1.89	28.76	1.38	1.34	1.37
5000.0	3.80	3.82	0.01	1.98	28.02	1.41	1.37	1.40
5200.0	3.83	3.84	0.01	2.05	26.53	1.42	1.39	1.41
5400.0	3.84	3.85	0.01	2.11	25.34	1.41	1.39	1.41
5600.0	3.85	3.86	0.01	2.17	24.16	1.40	1.39	1.41
5800.0	3.85	3.86	0.01	2.25	23.33	1.38	1.37	1.39
6000.0	3.85	3.86	0.01	2.31	22.59	1.36	1.35	1.36
6200.0	3.84	3.85	0.01	2.37	22.14	1.33	1.32	1.33
6400.0	3.84	3.85	0.00	2.41	21.83	1.29	1.30	1.30
6600.0	3.83	3.84	0.00	2.47	21.77	1.25	1.26	1.26
6800.0	3.83	3.83	0.00	2.51	21.76	1.20	1.24	1.23
7000.0	3.84	3.83	0.01	2.56	21.96	1.14	1.21	1.20
7200.0	3.85	3.83	0.01	2.59	22.34	1.08	1.20	1.18
7400.0	3.86	3.84	0.02	2.70	22.97	1.03	1.19	1.18
7600.0	3.89	3.85	0.03	2.74	23.73	1.03	1.19	1.18
7800.0	3.91	3.87	0.04	2.80	24.88	1.09	1.21	1.20
8000.0	3.94	3.90	0.05	2.85	26.18	1.13	1.23	1.22
8500.0	4.03	3.97	0.06	3.02	29.98	1.21	1.30	1.27
9000.0	4.14	4.04	0.10	3.10	32.23	1.25	1.40	1.33
9500.0	4.26	4.12	0.14	3.30	28.62	1.33	1.52	1.40
10000.0	4.31	4.13	0.19	3.64	22.28	1.30	1.53	1.40
10500.0	4.28	4.08	0.20	4.29	19.17	1.06	1.43	1.31
11000.0	4.36	4.17	0.19	4.80	19.86	1.25	1.46	1.33
11500.0	4.47	4.31	0.16	5.09	25.72	1.43	1.49	1.40
12000.0	4.47	4.32	0.15	5.24	24.27	1.33	1.30	1.29
12500.0	4.55	4.38	0.18	5.34	18.17	1.37	1.08	1.12
13000.0	4.65	4.43	0.22	5.70	16.47	1.39	1.14	1.05
13500.0	4.73	4.46	0.27	6.42	14.85	1.38	1.31	1.22
14000.0	4.95	4.70	0.25	7.82	11.49	1.63	1.57	1.50

⁽¹⁾ Total Loss = Insertion Loss + 3dB splitter loss.



P.O. Box 350166, Brooklyn, New York 11235-0003 (718) 934-4500 • Fax (718) 332-4661 For detailed performance specs & shopping online see Mini-Circuits web site
 The Design Engineers Search Engine Provides ACTUAL Data Instantly From MINI-CIRCUITS At: www.minicircuits.com



IF/RF MICROWAVE COMPONENTS

REV. OR
 EP2C+
 2/3/2015
 Page 3 of 3

Typical Performance Curves

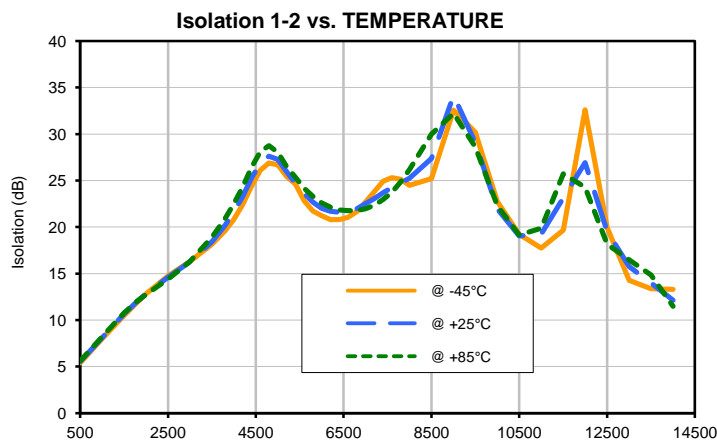
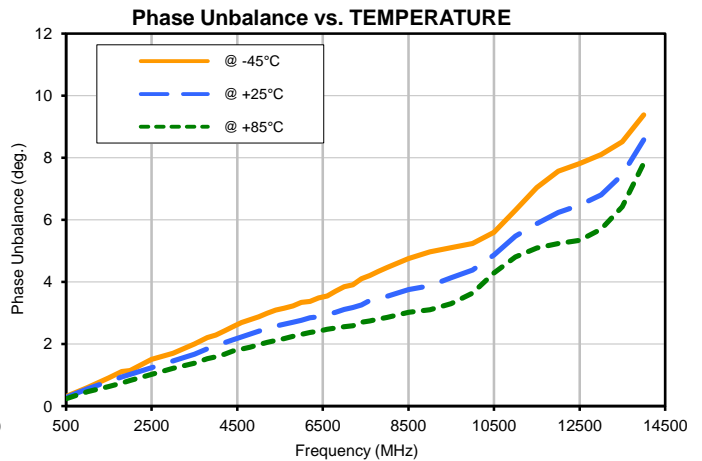
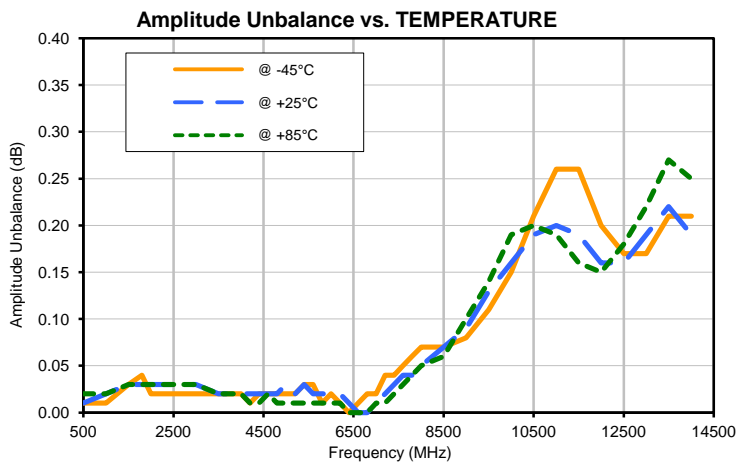
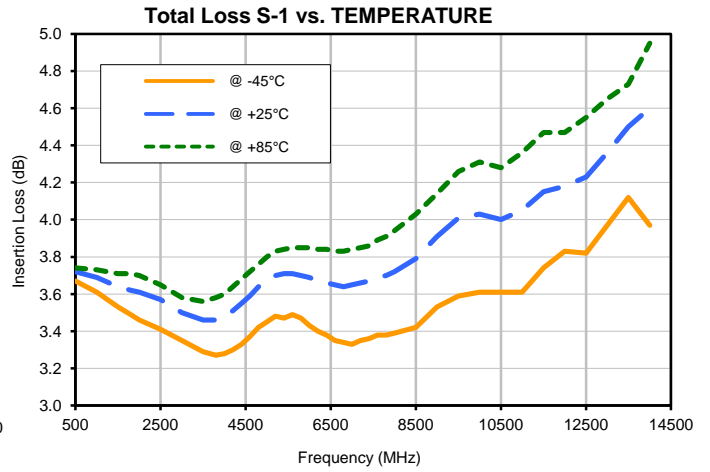
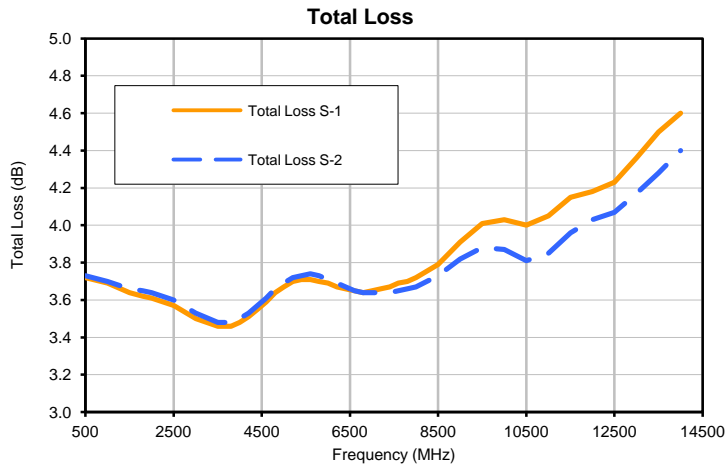

Typical Performance Curves

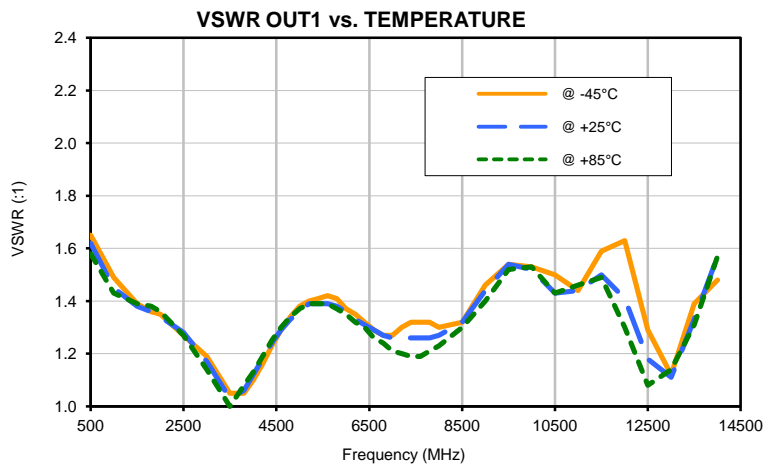
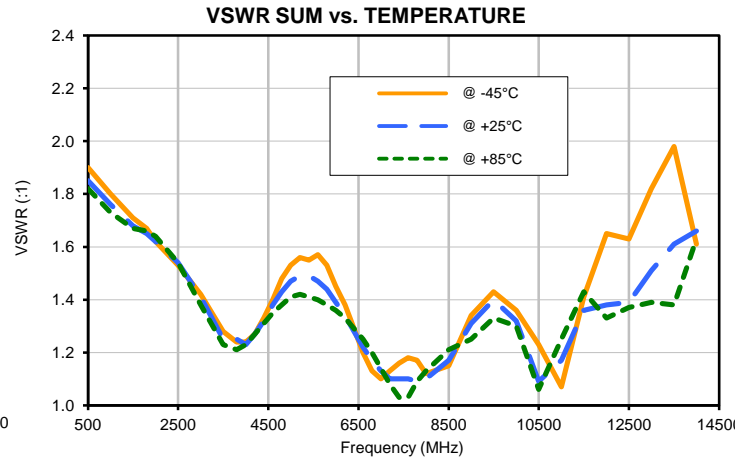
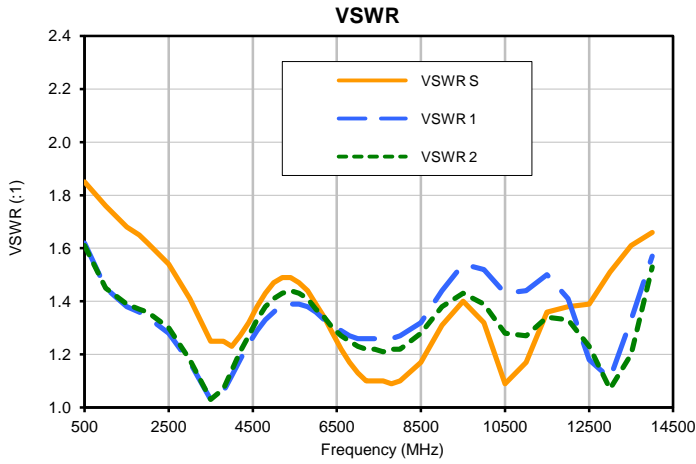

Outline Dimensions

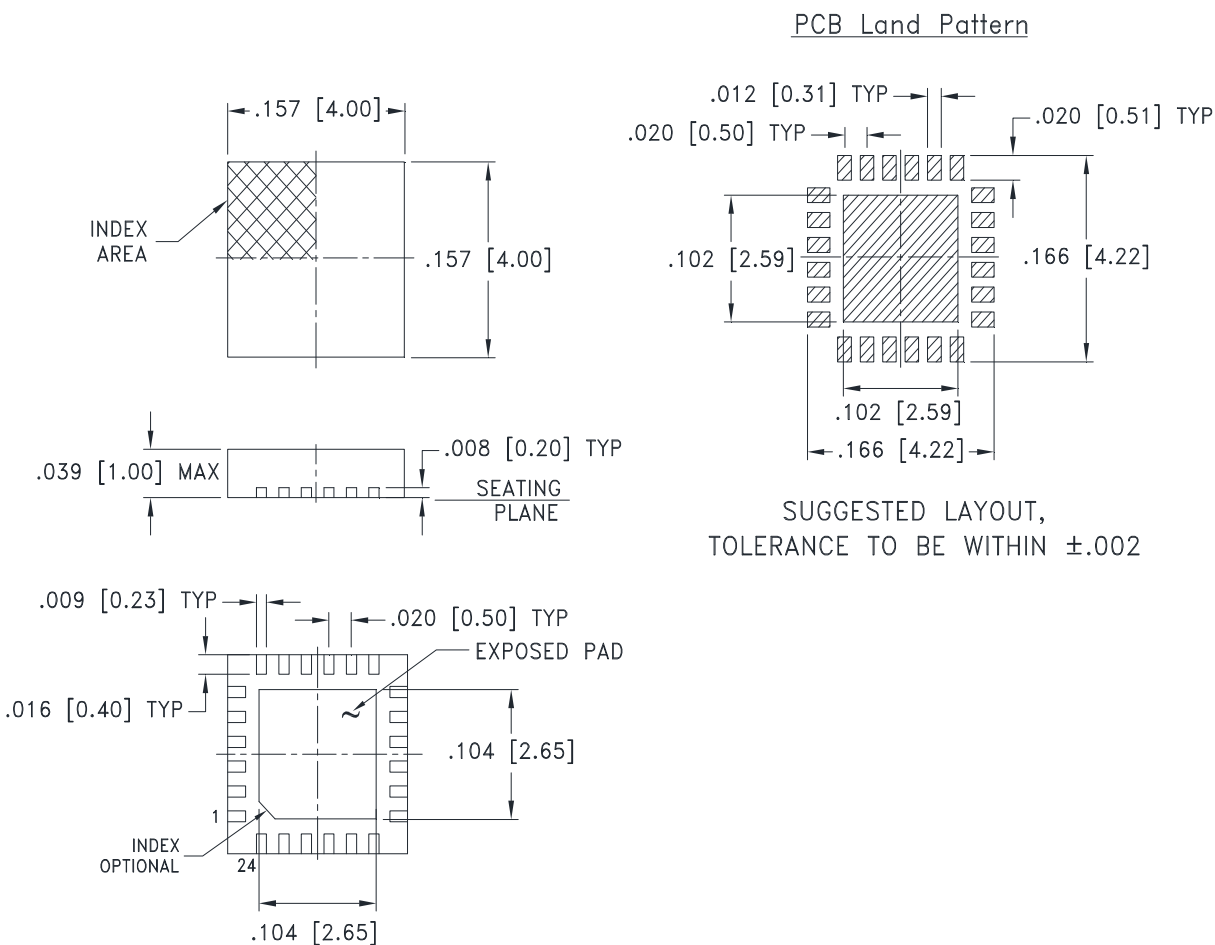

Weight: .04 Grams

Dimensions are in inches (mm). Tolerances: 2 Pl. \pm .01; 3 Pl. \pm .005

Notes:

1. Case material: Plastic.
2. Termination finish:
 - For RoHS Case Styles: Tin-Silver alloy plate over Nickel barrier or Matte-Tin. All models, (+) suffix. See model Data sheet.
 - For RoHS-5 Case Styles: Tin-Lead plate. All models, no (+) suffix.

Mini-Circuits®
ISO 9001 ISO 14001 CERTIFIED

ALL NEW
minicircuits.com

P.O. Box 350166, Brooklyn, New York 11235-0003 (718) 934-4500 Fax (718) 332-4661 For detailed performance specs & shopping online see Mini-Circuits web site



The Design Engineers Search Engine Provides ACTUAL Data Instantly From MINI-CIRCUITS At: www.minicircuits.com

RF/IF MICROWAVE COMPONENTS

DG1847 Rev.: AH (16 FEB 23) ECO-016811 File: DG1847

This document and its contents are the property of Mini-Circuits.

Tape & Reel Packaging TR-F68

DEVICE ORIENTATION IN T&R



Tape Width, mm	Device Cavity Pitch, mm	Reel Size, inches	Devices per Reel see note	
12	8	7	Small quantity standard	20
				50
				100
				200
				500
		7	Standard	1000
		13	Standard	2000
				3000
				4000

Mini-Circuits carrier tape materials provide protection from ESD (Electro-Static Discharge) during handling and transportation. Tapes are static dissipative and comply with industry standards EIA-481/EIA-541.

Go to: www.minicircuits.com/pages/pdfs/tape.pdf



INTERNET <http://www.minicircuits.com>

P.O. Box 350166, Brooklyn, New York 11235-0003 (718) 934-4500 Fax (718) 332-4661

Distribution Centers NORTH AMERICA 800-654-7949 • 417-335-5935 • Fax 417-335-5945 • EUROPE 44-1252-832600 • Fax 44-1252-837010

Mini-Circuits ISO 9001 & ISO 14001 Certified

THIRD ANGLE PROJECTION

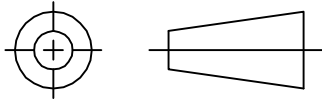

REVISIONS

REV	ECN No.	DESCRIPTION	DATE	DR	AUTH
OR	M148764	NEW RELEASE	11/03/14	GF	KN

**SUGGESTED MOUNTING CONFIGURATION
FOR DG1847 CASE STYLE, "24SP04" PIN CODE**

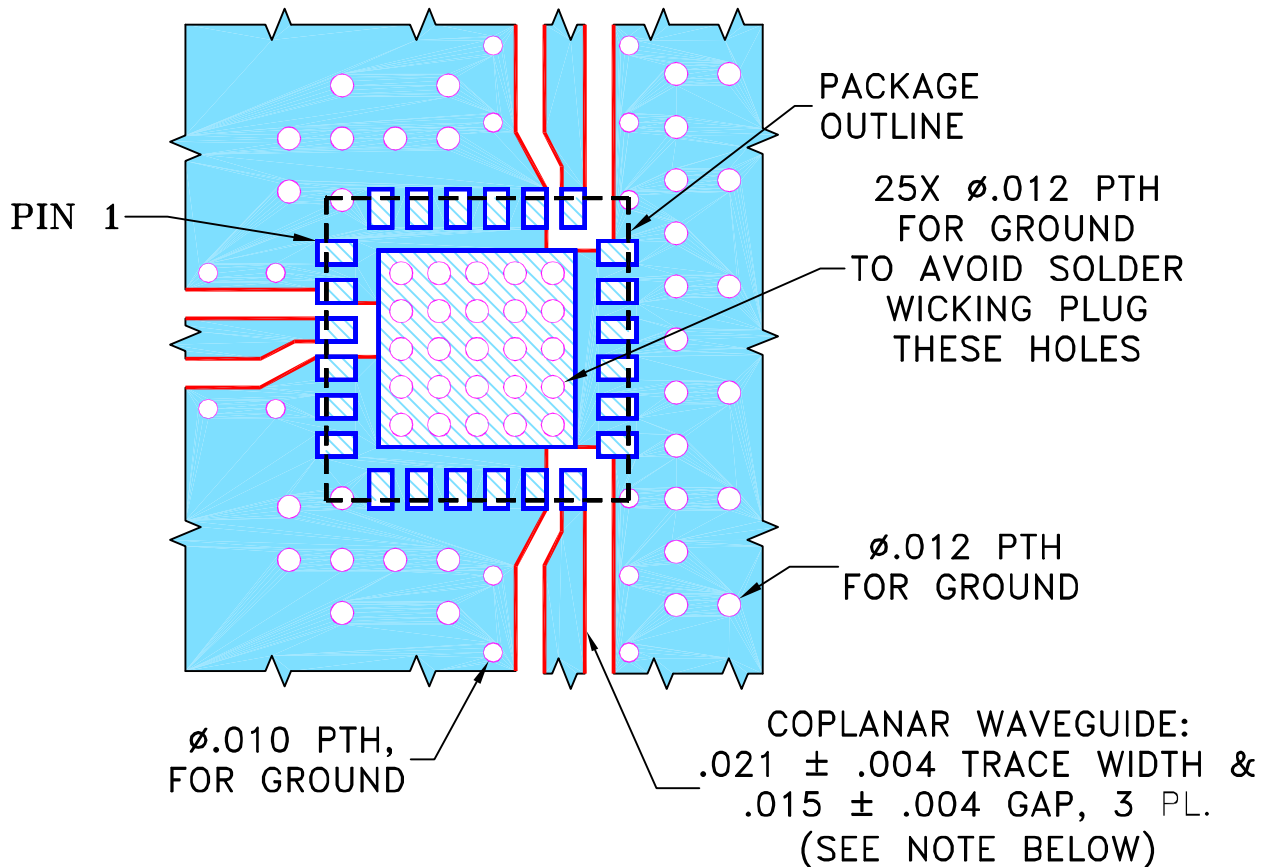

NOTES:

1. COPLANAR WAVEGUIDE IS SHOWN FOR ROGERS R04350B WITH DIELECTRIC THICKNESS .010" ± .001". COPPER: 1/2 OZ. EACH SIDE. FOR OTHER MATERIALS TRACE WIDTH AND GAP MAY NEED TO BE MODIFIED.
2. BOTTOM SIDE OF THE PCB IS CONTINUOUS GROUND PLANE.

 DENOTES PCB COPPER LAYOUT WITH SMOBC (SOLDER MASK OVER BARE COPPER).

 DENOTES COPPER LAND PATTERN FREE OF SOLDER MASK.

UNLESS OTHERWISE SPECIFIED	INITIALS	DATE
DRAWN	GF	10/27/14
CHECKED	AV	11/03/14
APPROVED	KN	11/03/14

 **Mini-Circuits®** 13 Neptune Avenue
Brooklyn NY 11235

PL, 24SP04, DG1847, TB-811+

Mini-Circuits®
THIS DOCUMENT AND ITS CONTENTS ARE THE PROPERTY OF MINI-CIRCUITS. EXCEPT FOR USE EXPRESSLY GRANTED, IN WRITING, TO ITS VENDORS, VENDEE AND THE UNITED STATES GOVERNMENT, MINI-CIRCUITS RESERVES ALL PROPRIETARY DESIGN, USE, MANUFACTURING AND REPRODUCTION RIGHTS THERETO. THESE CONTENTS SHALL NOT BE USED, DUPLICATED OR DISCLOSED TO ANY OUTSIDE PARTY, IN WHOLE OR IN PART, WITHOUT WRITTEN PERMISSION OF MINI-CIRCUITS.

SIZE	CODE IDENT	DRAWING NO:	REV:
A	15542	98-PL-442	OR
FILE:	98PL442	SCALE: 10:1	SHEET: 1 OF 1

Evaluation Board and Circuit

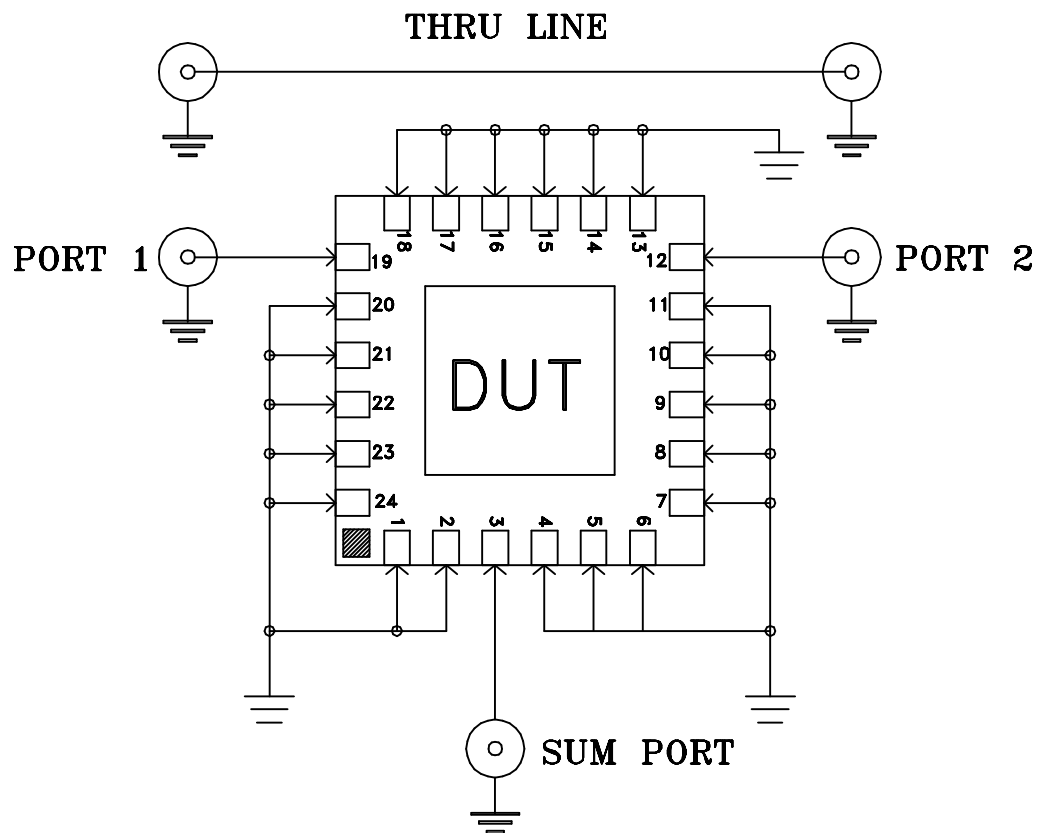
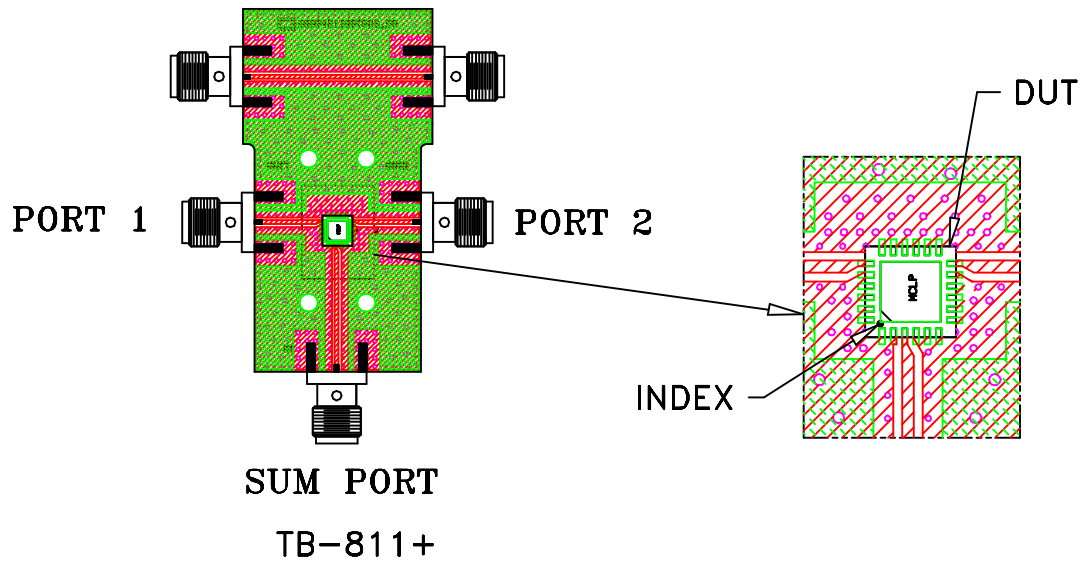

Schematic Diagram

Notes:

1. SMA Female Connectors.
2. PCB Material: Roger R04350B or equivalent,
Dielectric constant=3.5, Thickness=.010 inch

 **Mini-Circuits®**

All Mini-Circuits products are manufactured under exacting quality assurance and control standards, and are capable of meeting published specifications after being subjected to any or all of the following physical and environmental test.

Specification	Test/Inspection Condition	Reference/Spec
Operating Temperature	-40° to 85°C or -45° to 85°C Ambient Environment	Individual Model Data Sheet
Storage Temperature	-55° to 100° C or -65° to 150° Ambient Environment	Individual Model Data Sheet
Thermal Shock	-55° to 100°C, 100 cycles	MIL-STD-202, Method 107, Condition A-3, except +100°C
Mechanical Shock	1.5Kg, 0.5 ms, 5 shock pulses, Y1 direction only	MIL-STD-883, Method 2002, Condition B, except Y1 direction only
Vibration (Variable Frequency)	50g peak	MIL-STD-883, Method 2007, Condition B
Autoclave	15 psig, 100% RH, 121°C, 96 hours	JESD22-A102, Condition C
HAST	130°C, 85% RH, 96 hours	JESD22-A110
Solderability	10X Magnification	J-STD-002, Para 4.2.5, Test S, 95% Coverage
Solder Reflow Heat	Sn-Pb Eutetic Process: 240°C peak Pb-Free Process: 260°C peak	J-STD-020, Table 4-1, 4-2 and 5-2; Figure 5-1
Moisture Sensitivity: Level 1	Bake at 125°C for 24 hours Soak at 85°C/85% RH for 168 hours, Reflow 3 cycles at 260°C peak	J-STD-020
Marking Resistance to Solvents	Isopropyl alcohol + mineral spirits at 25°C; terpene defluxer at 25°C; distilled water + proylene glycol monomethyl ether +	MIL-STD-202, Method 215



All Mini-Circuits products are manufactured under exacting quality assurance and control standards, and are capable of meeting published specifications after being subjected to any or all of the following physical and environmental test.

Specification	Test/Inspection Condition	Reference/Spec
	monoethanolamine at 63°C to 70°C	