



Instrumentation Test Cable

E67-1M-EMEM+

Mini-Circuits

50Ω 1M DC to 67 GHz Low Loss 1.85mm-Male

THE BIG DEAL

- Ultra-wideband operation, DC to 67 GHz
- Stainless steel 1.85mm connectors for long mating-cycle life
- Low Insertion Loss and excellent Return Loss
- Very flexible with small bend radius 10mm



Generic photo used for illustration purposes only

APPLICATIONS

- Point to point or rack to rack connections
- High volume production test stations
- Research & development labs
- Environmental & temperature test chambers
- Replacement for OEM test port cables
- Field RF testing
- Cellular infrastructure site testing

Model No.	E67-1M-EMEM+
Case Style	UM3060-3.28
Connectors	1.85mm-Male

+RoHS Compliant

The +Suffix identifies RoHS Compliance. See our website for methodologies and qualifications

Product Guarantee

Mini-Circuits® will repair or replace your test cable at its option if the connector attachment fails within six months of shipment. This guarantee excludes cable or connector interface damage from misuse or abuse.

PRODUCT OVERVIEW

Mini-Circuits' E67 Model Series are ultra-wideband precision rugged instrumentation cables specially designed for use with 67 GHz VNA equipment in test environments. The cables provide excellent VSWR and very low insertion loss over its entire frequency range. 1.85mm straight to 1.85mm connector configuration provides direct connection from the ports of a 67 GHz VNA to 1.85mm connectorized devices without the need for adapters. These cables are available in a variety of lengths.

KEY FEATURES

Feature	Advantages
DC-67 GHz operation designed for use with Vector Network Analyzers (VNA)	Covers a wide range of test applications; rugged 1.85mm connector interfaces directly with VNA without the need for an adapter for improved VSWR performance and lower cost.
Stainless Steel Connectors	Stainless Steel Connectors maintains integrity of the cable-connector interface improving the reliability and extending life of use.
Anti-Torque Component	Nut component feature on connector used to fit a torque wrench to minimize stress on connectors and prevent breakage

REV. B
ECO-019694
E67-1M-EMEM+
MCL NY
240530





Instrumentation Test Cable

E67-1M-EMEM+

Mini-Circuits

50Ω 1M DC to 67 GHz Low Loss 1.85mm-Male

ELECTRICAL SPECIFICATIONS AT +25°C

Parameter	Frequency (GHz)	Min.	Typ.	Max.	Units
Frequency Range		DC	—	67	GHz
Length		1			M
Insertion Loss	DC - 26.5	—	2.4	4.3	dB
	26.5 - 40	—	4.2	5.5	
	40 - 50	—	5.0	6.4	
	50 - 67	—	5.9	6.9	
Return Loss	DC - 26.5	19	33.9	—	dB
	26.5 - 40	17	32	—	
	40 - 50	16	27	—	
	50 - 67	16	25.9	—	

ABSOLUTE MAXIMUM RATINGS

Parameter	Ratings
Operating Temperature	-55°C to +85°C
Storage Temperature	-55°C to +85°C
Power Handling at 25°C, Sea Level	57W at 1 GHz
	22W at 6 GHz
	12W at 18 GHz
	10W at 26.6 GHz
	8W at 40 GHz
	7W at 50 GHz
	6W at 67 GHz

Permanent damage may occur if any of these limits are exceeded.





Instrumentation Test Cable

E67-1M-EMEM+

Mini-Circuits

50Ω 1M DC to 67 GHz Low Loss 1.85mm-Male

CABLE CONSTRUCTION

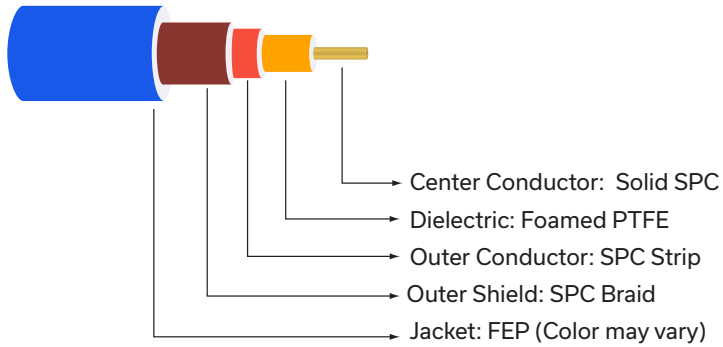

OUTLINE DRAWING

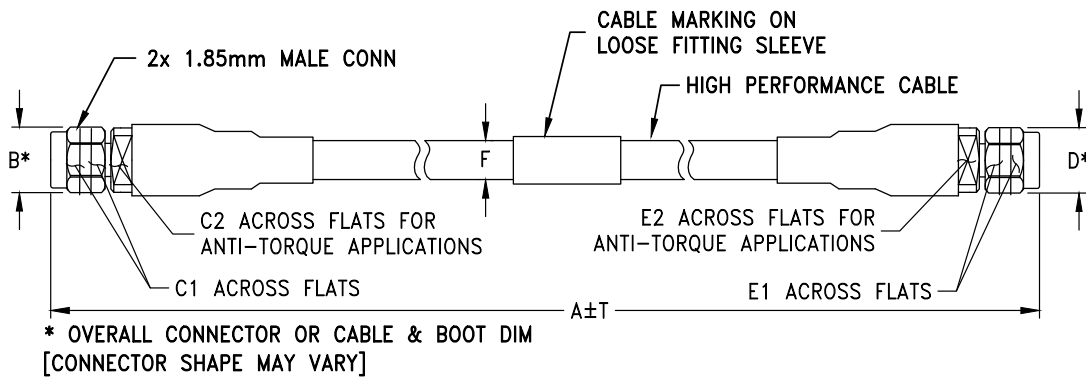

OUTLINE DIMENSIONS (Inch/mm)

A		B	C1	C2	D	E1	E2	F	T	wt	
Feet	Meters	0.36	.315	0.256	0.36	.315	.276	.100	Inch	MM	grams
3.28	1.00	9.14	8.00	6.50	9.14	8.00	6.50	2.54	0.08	2.00	42





Instrumentation Test Cable

E67-1M-EMEM+

Mini-Circuits

50Ω 1M DC to 67 GHz Low Loss 1.85mm-Male

TYPICAL PERFORMANCE DATA AND CHARTS

Frequency (MHz)	Insertion Loss (dB)	Return Loss (dB)	
		1.85mm-Male	1.8mm-Male
50	0.16	38.42	39.05
100	0.21	50.67	46.90
1000	0.64	38.82	37.88
5000	1.46	42.62	40.01
10000	2.14	25.96	26.07
20000	3.08	40.25	33.00
30000	3.90	35.44	31.41
40000	4.61	26.62	28.11
45000	4.96	23.27	22.07
50000	5.27	33.37	24.89
55000	5.59	24.81	25.22
60000	5.91	26.14	27.68
67000	6.43	24.01	26.39

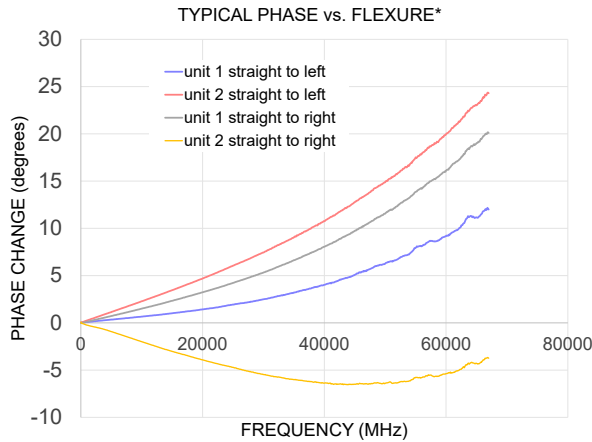

* Typical phase change over flexure performed on E67-1M-EMEM+ by wrapping cable 360° around 4" radii mandrels referenced to normalized straight position.
 ** Setup is flipped and measurement is repeated.

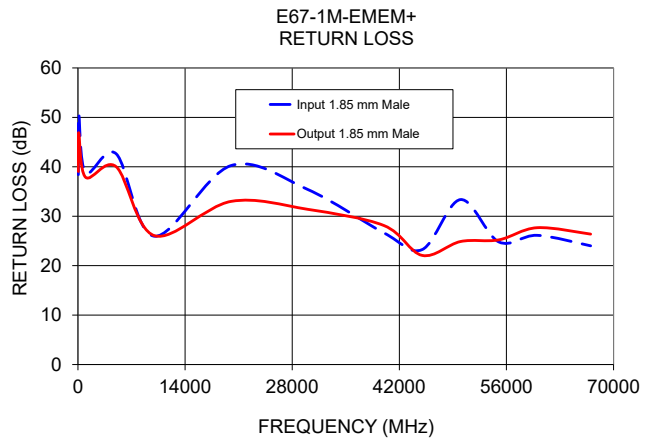
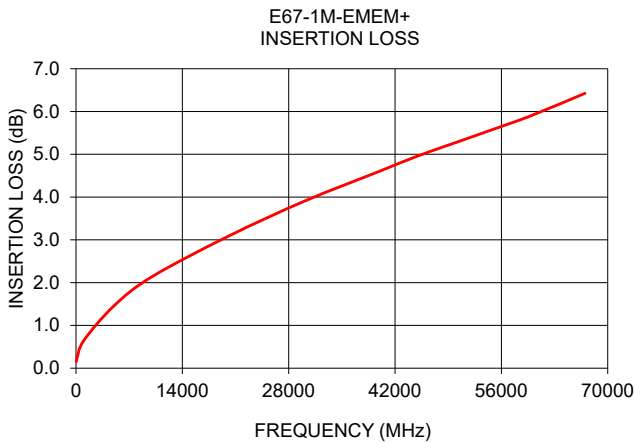



Mini-Circuits



Instrumentation Test Cable **E67-1M-EMEM+**

50Ω 1M DC to 67 GHz Low Loss 1.85mm-Male

PROPER CABLE CONNECTION USING ANTI-TORQUE NUT

Mini-Circuits E67 Series interconnect cables are constructed with an anti-torque nut adjacent to the connector coupling nut. When used properly, this feature prevents possible damage to the cable due to torquing and twisting when tightening the cable connector.

To properly tighten the cable connector:

1) The cable connector includes a coupling nut which rotates to fasten the connector, and an anti-torque nut, which is fixed to prevent the cable from twisting during connection.

2) To properly tighten the cable, use a standard 1/4-inch open end wrench to brace the anti-torque nut.

3) Using a 5/16-inch open end wrench, rotate the coupling nut clockwise to tighten the cable connector.

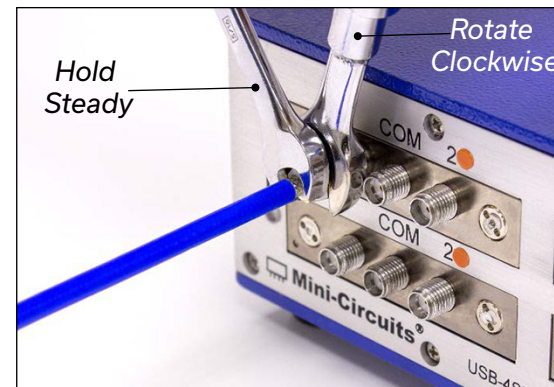
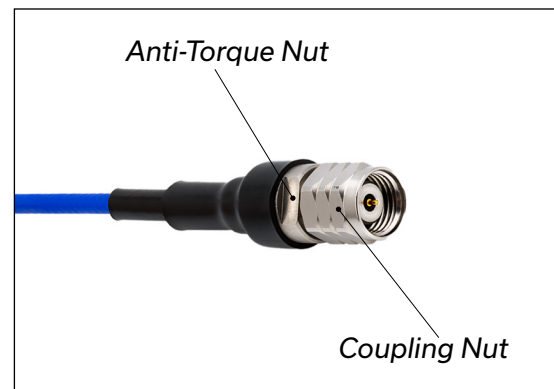

NOTE: Mini-Circuits recommends using a 5/16-inch open end wrench calibrated to 8 inch-pounds maximum torque to prevent damage due to over-torquing the connector.

NOTES

- A. Performance and quality attributes and conditions not expressly stated in this specification document are intended to be excluded and do not form a part of this specification document.
- B. Electrical specifications and performance data contained in this specification document are based on Mini-Circuit's applicable established test performance criteria and measurement instructions.
- C. The parts covered by this specification document are subject to Mini-Circuits standard limited warranty and terms and conditions (collectively, "Standard Terms"); Purchasers of this part are entitled to the rights and benefits contained therein. For a full statement of the standard terms and the exclusive rights and remedies thereunder, please visit Mini-Circuits' website at www.minicircuits.com/terms/viewterm.html



Typical Performance Data

FREQUENCY (MHz)	INSERTION LOSS (dB)	1.85mm-MALE 1 RETURN LOSS (dB)	1.85mm-MALE 2 RETURN LOSS (dB)
50	0.16	38.42	39.05
100	0.21	50.67	46.90
500	0.45	40.02	39.86
1000	0.64	38.82	37.88
2000	0.91	38.34	37.93
3000	1.11	34.96	34.87
4000	1.29	35.67	37.18
5000	1.46	42.62	40.01
6000	1.62	29.29	27.48
7000	1.76	29.64	28.95
8000	1.89	37.11	34.39
9000	2.01	35.73	30.14
10000	2.14	25.96	26.07
11000	2.24	26.60	26.11
12000	2.34	32.35	30.95
13000	2.44	39.76	36.98
14000	2.54	30.14	27.97
15000	2.64	30.35	31.38
16000	2.73	35.74	57.11
17000	2.82	33.61	34.91
18000	2.91	27.52	27.68
19000	2.99	36.05	35.46
20000	3.08	40.25	33.00
21000	3.16	30.05	30.68
22000	3.25	32.90	36.37
23000	3.33	33.11	36.41
24000	3.42	60.08	44.25
25000	3.49	35.45	37.65
26000	3.58	39.48	42.21
26500	3.62	34.87	42.02
27000	3.66	31.66	32.19
28000	3.74	37.69	31.33
30000	3.90	35.44	31.41
32000	4.03	45.79	33.45
34000	4.19	32.76	28.09
36000	4.33	32.86	26.82
38000	4.48	27.96	28.13
40000	4.61	26.62	28.11
42000	4.76	26.02	24.85
44000	4.89	25.73	23.81
46000	5.04	23.10	24.05
48000	5.19	21.20	20.66
50000	5.27	33.37	24.89
52000	5.41	28.47	24.25
54000	5.53	31.25	28.82
56000	5.67	25.54	25.47
58000	5.77	26.15	31.07
60000	5.91	26.14	27.68
62000	6.07	29.47	24.53
64000	6.22	23.76	21.73
66000	6.45	18.69	18.61
67000	6.43	24.01	26.39

Ultra Flex Test Cable, 1.85mm-M/1.85mm-M E67-1M-EMEM+

Typical Performance Curves

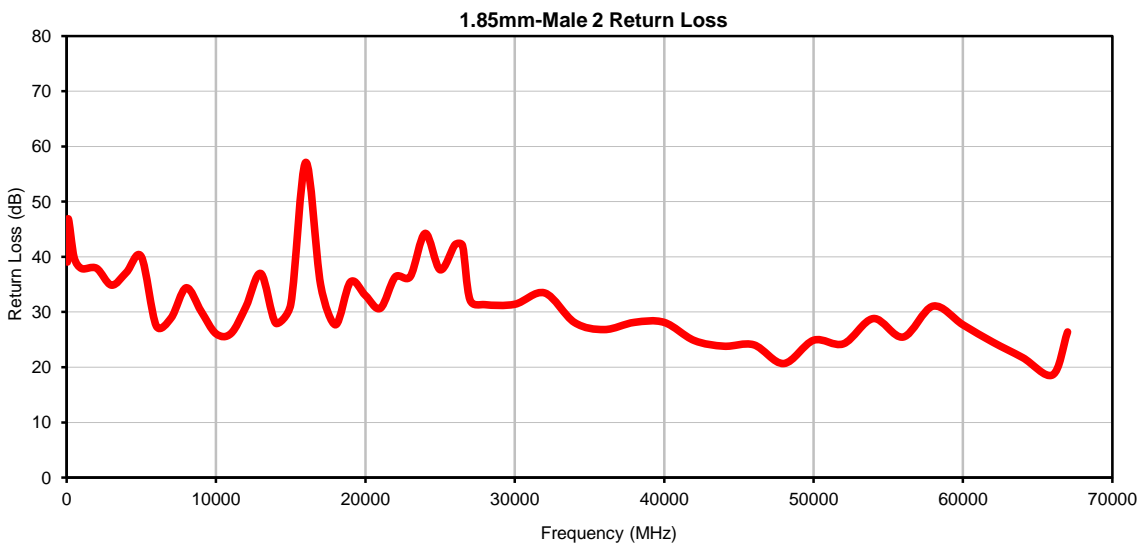
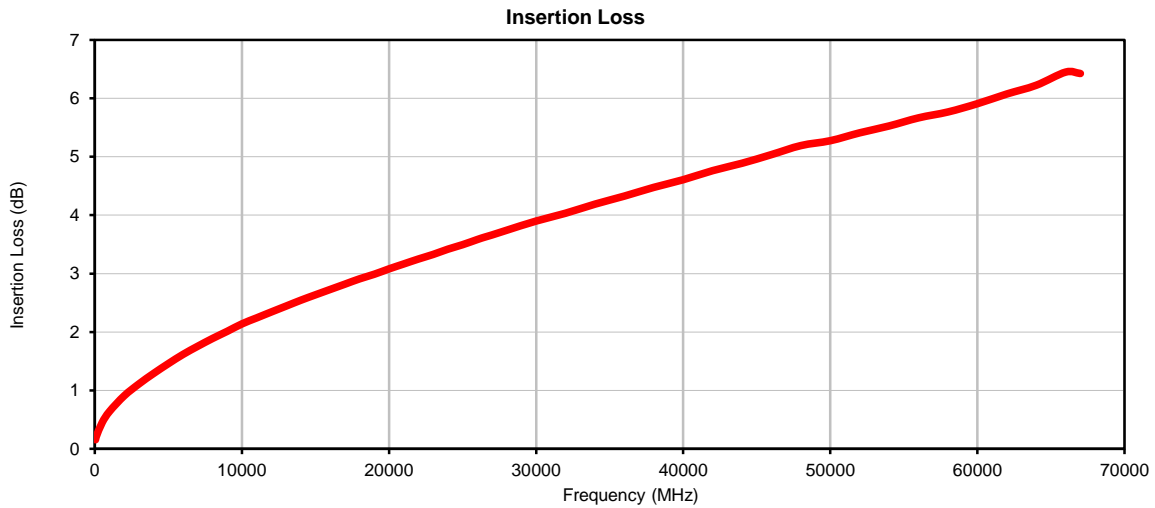

Case Style

UM

Outline Dimensions

UM3060

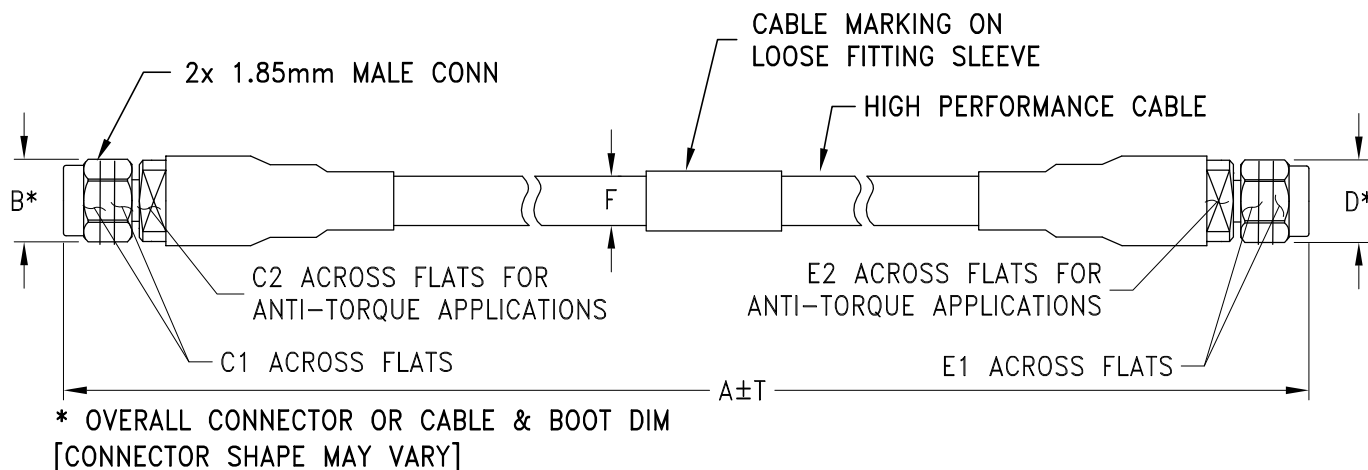

UM3060 SERIES 1.85 MM MALE (CONN)

CASE STYLE #	A		B	C1	C2	D	E1	E2	F	T		WT. (GRAMS)
	FEET	M								INCH	MM	
UM3060-1.64	1.64	0.50								.08	2.0	34.0
UM3060-2.00	2.00	0.61	0.36	.315	.256	.36	.315	.256	.100	.08	2.0	35.0
UM3060-3.00	3.00	0.91	[9.14]	[8.00]	[6.50]	[9.14]	[8.00]	[6.50]	[2.54]	.08	2.0	40.0
UM3060-3.28	3.28	1.00								.08	2.0	42.0

Unless otherwise specified dimensions are in inches (mm).

Tolerances: 2 Pl. ±.03; 3 Pl. ±.015

Note:

1. E67 Flexible Coaxial Cable.
2. "A" Represents Length of Cable.

Mini-Circuits®
ISO 9001 ISO 14001 CERTIFIED

ALL NEW
minicircuits.com

P.O. Box 350166, Brooklyn, New York 11235-0003 (718) 934-4500 Fax (718) 332-4661 For detailed performance specs & shopping online see Mini-Circuits web site



The Design Engineers Search Engine Provides ACTUAL Data Instantly From MINI-CIRCUITS At: www.minicircuits.com

RF/IF MICROWAVE COMPONENTS



All Mini-Circuits products are manufactured under exacting quality assurance and control standards, and are capable of meeting published specifications after being subjected to any or all of the following physical and environmental test.

Specification	Test/Inspection Condition	Reference/Spec
Operating Temperature	-40° to 70° C Ambient Environment	Individual Model Data Sheet
Storage Temperature	-55° to 85° C Ambient Environment	Individual Model Data Sheet
Mechanical Flexing	4,000 cycles During each cycle, cable flexed from 90° through 0° to -90° and back with a Radii of 3 inches	---