

# Digital Controlled Variable Gain Amplifier

## DVGA3-122+

50Ω 0.9 to 1.2 GHz  
31.5 dB, 0.5 dB Step, 6 Bit Serial Control

### The Big Deal

- Integrated Amplifier, Reflectionless Filter and Digital Attenuator
- 20 dB Gain / 31.5 dB Gain Control
- Flat frequency response,  $\pm 0.85$  dB (0.9-1.2 GHz)

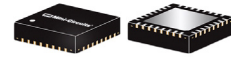

CASE STYLE: DG1677-2

### Product Overview

The DVGA3-122+ is a multi-chip module that consists of a low noise amplifier, a voltage control attenuator with 6-bit serial control and a low pass reflection-less filter. It operates on a single 5v supply and well matched for 50Ω. It comes in a tiny, low profile package (5x5x0.89mm), accommodating dense circuit board layouts.

### Key Features

Feature	Advantages
31.5 dB attenuation in 0.5 dB step size	Combining medium gain and a wide range of gain control makes the DVGA3-122+ an ideal building block for any RF chain where level setting control is required in a small space.
Flat frequency response, $\pm 0.85$ dB over 0.9-1.2 GHz	No need for external components to flatten gain.
Medium Gain, 20 dB	Incorporating multiple stages of amplification, the DVGA3-122+ provides medium gain over a wideband reducing cost and PCB board space.
Good IP3, +28 dBm at 1.0 GHz	Use in receivers and transmitters giving the users advantage in instantaneous spur free dynamic range over wide bandwidths.
Output Power, +15.6 dBm at 1.0 GHz	The DVGA3-122+ maintains consistent output power capability over the full attenuation range and operating temperature range making it ideal to be used in remote applications such as LNB's as the L Band driver stage.
5x5 mm 32-lead MCLP package	Tiny footprint saves space in dense layouts while providing low inductance, repeatable transitions, and excellent thermal contact to the PCB.

# Digital Controlled Variable Gain Amplifier

50Ω 0.9 - 1.2 GHz

20 dB Gain, 0.5 dB Step, 31.5 dB Attenuation, 6 Bit Serial Control

## Product Features

- 31.5 dB Gain control 0.5dB step size
- Gain, 20 dB typ. at 1 GHz
- Serial control interface
- Small size 5.0 x 5.0 mm

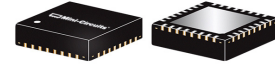

Generic photo used for illustration purposes only

## DVGA3-122+

CASE STYLE: DG1677-2

## Typical Applications

- Radio Location
- Fixed Satellite
- Space Research

**+RoHS Compliant**

The +Suffix identifies RoHS Compliance. See our web site for RoHS Compliance methodologies and qualifications

## General Description

The DVGA3-122+ is a multi-chip module that consists of a low noise amplifier, a voltage control attenuator with 6-bit serial control and a low pass reflection-less filter. It operates on a single 5v supply and well matched for 50Ω. It comes in a tiny, low profile package (5x5x0.89mm), accommodating dense circuit board layouts.

## Simplified Schematic of DUT

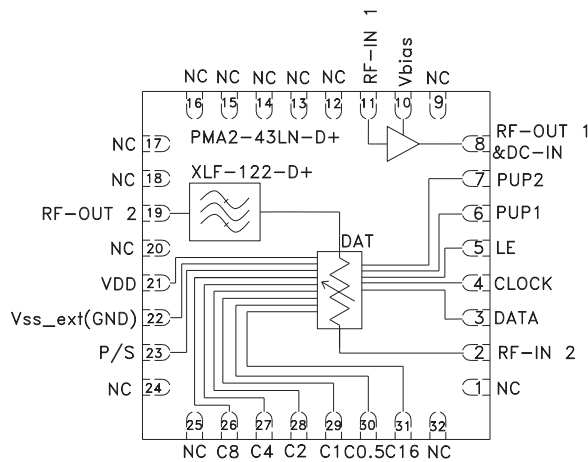

## TOP VIEW

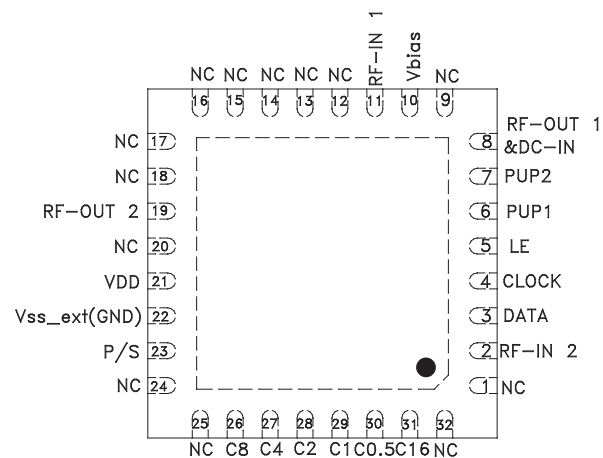

## Simplified Schematic of DAT

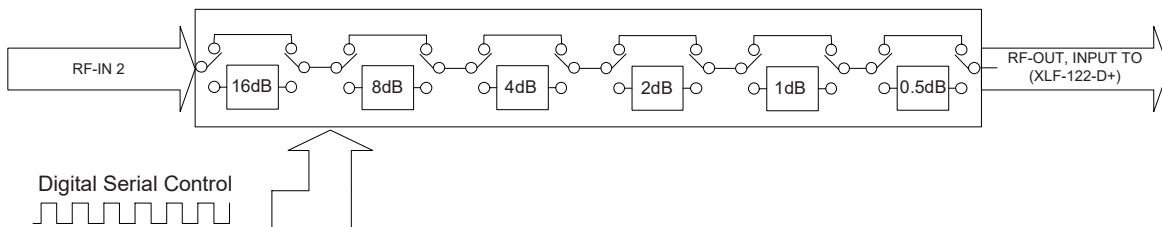

Pad Description (Table 1)

Pad Number	Function	Pad Description (See Figure 1 for TB-DVGA3-122+ Drawing)
2	RF-IN 2	RF Input Pad of the Digital Control Attenuator (DAT) (Note 1)
3	DATA	Data Pad of DAT (Note 3)
4	CLOCK	Clock Pad of DAT
5	LE	Latch Enable Pad of DAT (Note 2)
6	PUP1	Power Up Pad of DAT. Grounded externally on Test Board via 10K Resistor(R15)
7	PUP2	Power Up Pad of DAT. Grounded externally on Test Board via 10K Resistor(R14)
8	RF-OUT 1 & DC-IN	RF Output & DC Supply Pad of Amplifier. Connects to VS per Figure 1.
10	Vbias	Biasing Voltage Pad of Amplifier. Connects to VS per Figure 1.
11	RF-IN 1	RF Input Pad of Amplifier. Connects to Vbias per Figure 1.
19	RF-OUT 2	RF Output Pad of Reflection-less Low Pass Filter (Note 1)
21	VDD	DC Supply Pad of DAT. Connects to VS per Figure 1
22	Vss_ext(GND)	Control pad to internal negative voltage generator of DAT. Connects to ground per Figure 1
23	P/S	P/S Pad of DAT. Connects to VS per Figure 1
26	C8	Attenuation Control Bit (8dB). Connects to ground via a 10Kohm Resistor (Note 4)
27	C4	Attenuation Control Bit (4dB). Connects to ground via a 10Kohm Resistor (Note 4)
28	C2	Attenuation Control Bit (2dB). Connects to ground via a 10Kohm Resistor (Note 4)
29	C1	Attenuation Control Bit (1dB). Connects to ground via a 10Kohm Resistor (Note 4)
30	C0.5	Attenuation Control Bit (0.5dB). Connects to ground via a 10Kohm Resistor (Note 4)
31	C16	Attenuation Control Bit (16dB). Connects to ground via a 10Kohm Resistor (Note 4)
1,9,12-18,20,24, 25 & 32	NC	Not Connected. Grounded on test board.
Paddle	Ground	Ground (Note 5).

## Notes:

- RF input and output ports shall be AC coupled with external blocking capacitor.
- Latch Enable (LE) has an internal 2M $\Omega$  pull-up resistor to VDD (Pin 21).
- Place a shunt 10K $\Omega$  resistor to avoid freq. resonance (see layout drawing PL-655).
- Refer to Power-up Control Settings.
- The exposed solder pad on the bottom of the package (See Pin Configuration) must be grounded for proper device operation.
- See application and characterization test circuit Fig. 1 and layout drawing PL-655.

RF Electrical Specifications<sup>1</sup> at 25°C, 50Ω With Vs=5V

Parameter	Condition (MHz)	Min.	Typ.	Max.	Units
Frequency Range		900		1200	MHz
Gain (at 0 dB attenuation)	900	18.3	20.4	22.4	dB
	1000	18.0	20.0	22.0	
	1100	17.5	19.4	21.3	
	1200	16.8	18.7	20.6	
Input Return Loss (all states)	900		7		dB
	1000		9		
	1100		10		
	1200		11		
Output Return Loss (all states)	900		6		dB
	1000		7		
	1100		8		
	1200		9		
Output Power @ 1 dB compression (at 0 dB attenuation)	900		15.4		dBm
	1000		15.6		
	1100		15.7		
	1200		15.7		
Output IP3 (at 0 dB attenuation)	900		27.0		dBm
	1000		28.0		
	1100		28.2		
	1200		28.1		
Noise Figure (at 0 dB attenuation)	900		0.5		dB
	1000		0.5		
	1100		0.5		
	1200		0.5		
Accuracy @ 0.5 dB Attenuation Setting	900 - 1200		0.07	0.4	dB
Accuracy @ 1 dB Attenuation Setting	900 - 1200		0.11	0.5	dB
Accuracy @ 2 dB Attenuation Setting	900 - 1200		0.03	0.3	dB
Accuracy @ 4 dB Attenuation Setting	900 - 1200		0.05	0.3	dB
Accuracy @ 8 dB Attenuation Setting	900 - 1200		0.01	0.5	dB
Accuracy @ 16 dB Attenuation Setting	900 - 1200		0.11	0.8	dB
Supply Voltage (Vs)	DC	4.75	5.0	5.25	V
Supply Current (Is)	DC		52.2	64.2	mA
Current Variation vs. Temperature <sup>2</sup>			-29.5		mA/°C
Current Variation vs. Voltage <sup>3</sup>			0.015		mA/mV
Thermal Resistance, Junction to ground lead (Amplifier)		—	61	—	°C/W

1. Measured in Mini-Circuits characterization test board TB-DVGA3-122+. See characterization Test Circuit (Fig. 1)
2. Device Current Variation vs. Temperature = (Current at 85°C – Current at -45°C)/ 130°C
3. Device Current Variation vs. Voltage = (Current at 5.25V – Current at 4.75V)/(5.25V-4.75V)

Absolute Maximum Ratings<sup>4</sup>

Parameter	Ratings
Operating Temperature (ground pad)	-40°C to 85°C
Storage Temperature	-65°C to 150°C
Supply Voltage Vs	5.5V Max.
Input Power	XLF-122-D+ at Passband: +33 dBm PMA2-43LN-D+: +22 dBm DAT: +30 dBm
Total Power Dissipation	PMA2-43LN-D+: 0.7W DAT: 1W

4. Permanent damage may occur if any of these limits are exceeded.

Control Voltage<sup>5</sup>

Parameter	Min.	Typ.	Max.	Units
Control Input Low	-0.3	—	0.6	V
Control Input High	1.17	—	3.6	V
Control Current <sup>6</sup>	—	—	20	mA

5. Applicable to Data (Pad#3), Clock (Pad#4), LE (Pad#5), PUP1 (Pad#6), PUP2 (Pad#7), C0.5-C16 (Pad#27-31).
6. Except 30mA typ. for C0.5, C16

**Attenuation Switching Specifications**

Parameter	Min.	Typ.	Max.	Units
Switching Speed, 50% Control to 0.5dB of Attenuation Value	—	1.0	—	mSec
Switching Rep Rate	—	—	25	KHz

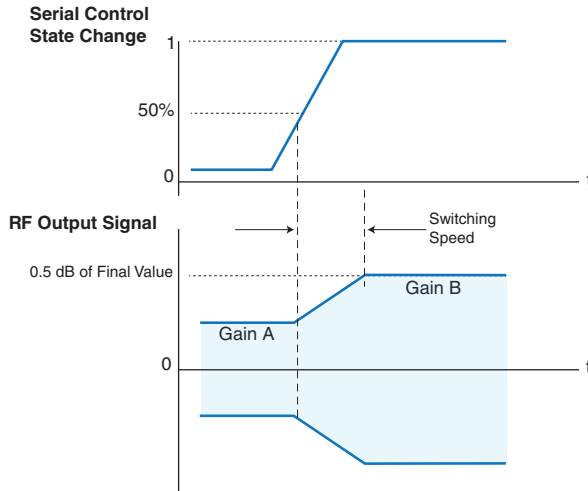

**Table 2. Truth Table**

Attenuation State	C16	C8	C4	C2	C1	C0.5
Reference	0	0	0	0	0	0
0.5 (dB)	0	0	0	0	0	1
1 (dB)	0	0	0	0	1	0
2 (dB)	0	0	0	1	0	0
4 (dB)	0	0	1	0	0	0
8 (dB)	0	1	0	0	0	0
16 (dB)	1	0	0	0	0	0
31.5 (dB)	1	1	1	1	1	1

Note: Not all 64 possible combinations of C0.5 - C16 are shown in table

The serial interface is a 6-bit serial in, parallel-out shift register buffered by a transparent latch. It is controlled by three CMOS-compatible signals: Data, Clock, and Latch Enable (LE). The Data and Clock inputs allow data to be serially entered into the shift register, a process that is independent of the state of the LE input. The LE input controls the latch. When LE is HIGH, the latch is transparent and the contents of the serial shift register control the attenuator. When LE is brought LOW, data in the shift register is latched. The shift register should be loaded while LE is held LOW to prevent the attenuator value from changing as data is entered. The LE input should then be toggled HIGH and brought LOW again, latching the new data. The timing for this operation is defined by Figure 2 (Serial Interface Timing Diagram) and Table 3 (Serial Interface AC Characteristics).

**Product Marking**

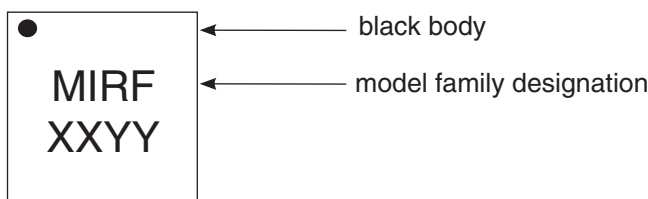

## Application and Characterization Test Circuit

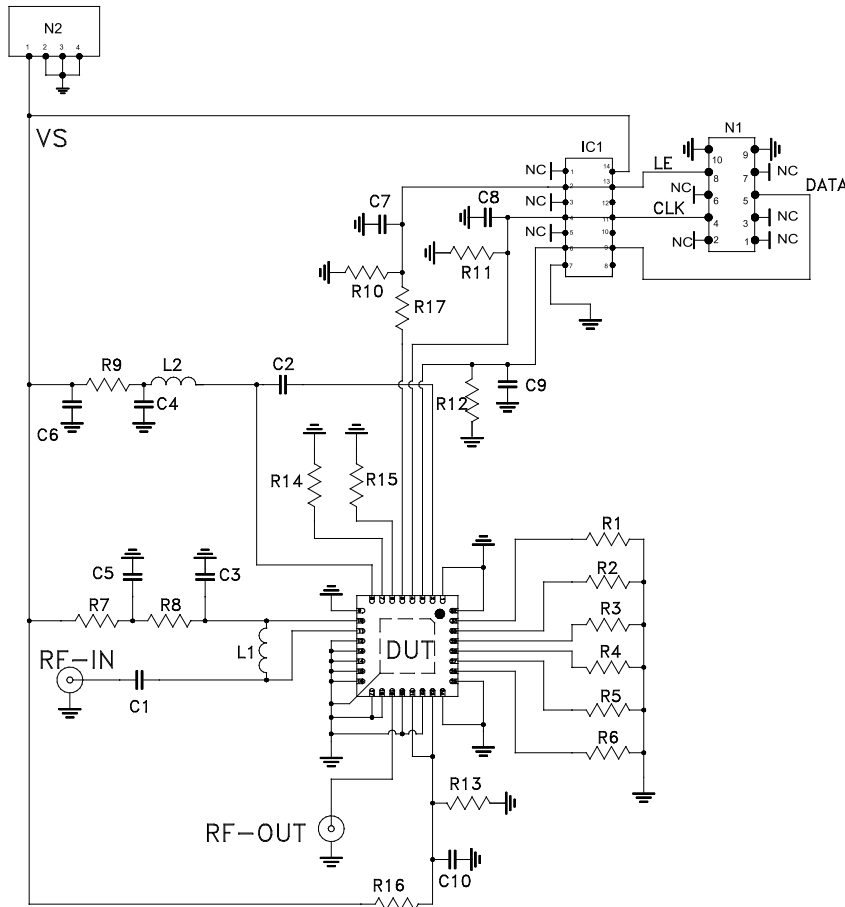

Component	Size	Value	P/N	Manufacturer
DUT	5x5mm	Amplifier	DVGA3-122+	MCL
IC1	--	Hex Inverting Schmitt Trigger	MM74HC14M	Fairchild Semiconductor
N1	--	Vertical Breakaway Header 10 Circuits	015-91-0100	Molex
N2	--	Vertical Header 4 Circuits	53398-0471	Molex
C1,C2	0402	0.001uF	GRm1555C1H102JA01D	Murata
C3,C4	0402	100pF	04025A101JAT2A	AVX or Equivalent
C5,C6	0603	4.7uF	JMK105BJ475MV-F	Taiyo Yuden Inc.
C7,C8,C9	0603	100pF	GRM1885C1H101JA01D	Murata
C10	0805	0.47uF	TMCP1D104KTRXF	Holy Stone
R1-R6	0603	10KOhm	RK73H1JTTD1002F	KOA
R7	0402	5.11kOhm	RK73H1ETTP5111F	KOA
R8	0805	49.9Ohm	RK73H1ETTP49R9F	KOA
R9	0603	0 Ohm	KR73Z1JTTD	KOA
R10-R12,R14&R15	0603	10KOhm	RK73H1JTTD1002F	KOA
R13	0603	6810hm	RK73H1JTTD4750F	KOA
R16	0603	4750hm	RK73H1ETTP6810F	KOA
L1	0402	10nH	LQW15AN10NH00D	Murata
L2	0402	8.2nH	LQW15AN8N2GOOD	Murata
R17	0805	10KOhm	RK73H2ATTD1002F	KOA

**Figure 1.** Block diagram of Test Circuit used for characterization. (DUT soldered on Mini-Circuits Characterization Test Board TB-DVGA3-122+). Gain, Return Loss, Output power at 1dB Compression (P1dB), Output IP3 and noise figure are measured using Agilent's N52244A-PNA-X Microwave network analyzer.

Condition:

1. Gain and Return Loss: Pin=-25 dBm
2. Output IP3 (OIP3): Two tones, spaced 1 MHz apart, +5dBm/Tone at Output.

Table 3. Serial Interface AC Characteristics

Symbol	Parameter	Min.	Max.	Units
$f_{clk}$	Serial data clock frequency (Note 1)		10	MHz
$t_{clkH}$	Serial clock HIGH time	30		ns
$t_{clkL}$	Serial clock LOW time	30		ns
$t_{LESUP}$	LE set-up time after last clock falling edge	10		ns
$t_{LEPW}$	LE minimum pulse width	30		ns
$t_{SDSUP}$	Serial data set-up time before clock rising edge	10		ns
$t_{SDHLD}$	Serial data hold time after clock falling edge	10		ns

Note 1.  $f_{clk}$  verified during the functional pattern test. Serial programming sections of the functional pattern are clocked at 10MHz to verify  $f_{clk}$  specification.

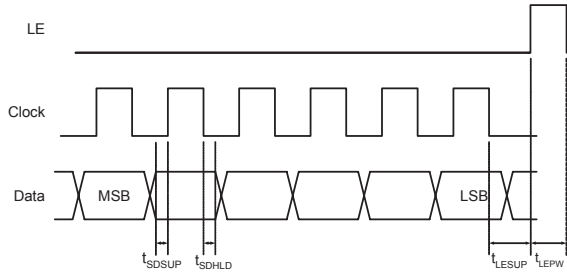

Figure 2. Serial Interface Timing Diagram

The DVGA3-122+, uses a common 6-bit serial, as shown in Table 4: 6-Bit attenuator Serial Programming Register Map. The first bit, the MSB, corresponds to the 16-dB Step and the last bit, the LSB, corresponds to the 0.5dB step.

Table 4. 6-Bit attenuator Serial Programming Register Map

B5	B4	B3	B2	B1	B0
C16	C8	C4	C2	C1	C0.5

↑  
MSB  
(first in)

↑  
LSB  
(last in)

### Power-up Control Settings

The DVGA3-122+ always assumes a specifiable attenuation setting on power-up, allowing a known attenuation state to be established before an initial serial control word is provided. When the attenuator powers up, the six control bits are set to whatever data is present on the six control inputs (C0.5 to C16). This allows any one of the 64 attenuation settings to be specified as the power-up state.

<b>Additional Detailed Technical Information</b>	
<i>additional information is available on our dash board. To access this information <a href="#">click here</a></i>	
<b>Performance Data</b>	Data Table
	Swept Graphs
	S-Parameter (S2P Files) Data Set (.zip file)
<b>Case Style</b>	DG1677-2 <i>Plastic package, exposed paddle, lead finish: Matte-Tin</i>
<b>Tape &amp; Reel</b> Standard quantities available on reel	F68 <i>7" reels with 20,50,100,200, 500 or 1K devices</i> <i>13" reels with 2K, 3K, &amp; 4K devices</i>
<b>Suggested Layout for PCB Design</b>	PL-655
<b>Evaluation Board</b>	TB-DVGA3-122+
<b>Environmental Ratings</b>	ENV08T1

**ESD Rating**

Human Body Model (HBM): Class 1A (250 to <500V) in accordance with ANSI/ESD STM 5.1 - 2001

**MSL Rating**

Moisture Sensitivity: MSL1 in accordance with IPC/JEDEC J-STD-020D

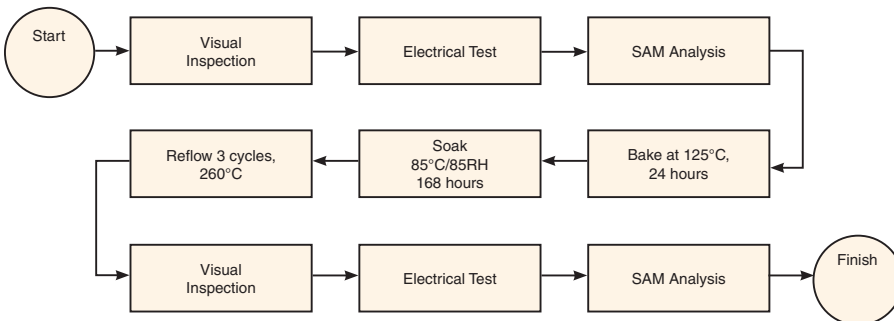

**Additional Notes**

- A. Performance and quality attributes and conditions not expressly stated in this specification document are intended to be excluded and do not form a part of this specification document.
- B. Electrical specifications and performance data contained in this specification document are based on Mini-Circuit's applicable established test performance criteria and measurement instructions.
- C. The parts covered by this specification document are subject to Mini-Circuits standard limited warranty and terms and conditions (collectively, "Standard Terms"); Purchasers of this part are entitled to the rights and benefits contained therein. For a full statement of the Standard Terms and the exclusive rights and remedies thereunder, please visit Mini-Circuits' website at [www.minicircuits.com/MCLStore/terms.jsp](http://www.minicircuits.com/MCLStore/terms.jsp)



## Typical Performance Data

**NOTE: Use PDF Bookmarks to view DATA at required conditions**

**Definitions:**

Input Return Loss = -S11 (dB)

Gain(Power Gain) = S21 (dB)

Reverse Isolation = -S12 (dB)

Output Return Loss = -S22 (dB)

TEST CONDITIONS: Vd = 5.00V, Id = 50.85mA @ Temperature = +25°C

FREQ	Gain	Isolation	Input Return Loss	Output Return Loss	Stability		IP-3 Output	1dB Comp. Output	Noise Figure
					K	Measure			
(MHz)	(dB)	(dB)	(dB)	(dB)	K	Measure	(dBm)	(dBm)	(dB)
700	20.04	41.32	4.03	5.06	2.81	0.89	24.55	13.87	0.62
800	20.41	39.08	5.83	5.70	2.63	0.85	25.79	14.87	0.53
850	20.42	38.30	6.74	6.05	2.60	0.84	26.25	15.19	0.48
900	20.34	37.70	7.59	6.41	2.60	0.84	26.71	15.41	0.49
910	20.31	37.60	7.76	6.47	2.60	0.84	26.91	15.51	0.42
920	20.28	37.51	7.93	6.55	2.61	0.84	27.00	15.37	0.50
930	20.24	37.41	8.09	6.62	2.62	0.84	27.02	15.48	0.66
940	20.20	37.33	8.24	6.69	2.62	0.84	27.20	15.47	0.43
950	20.17	37.26	8.40	6.77	2.63	0.84	27.34	15.74	0.43
960	20.13	37.18	8.56	6.84	2.65	0.84	27.18	15.79	0.49
970	20.08	37.10	8.71	6.91	2.65	0.84	27.03	15.80	0.40
980	20.04	37.04	8.86	6.98	2.67	0.85	27.23	15.50	0.47
990	19.99	36.96	9.01	7.05	2.68	0.85	27.58	15.39	0.43
1000	19.94	36.90	9.16	7.13	2.69	0.85	27.84	15.67	0.53
1010	19.89	36.84	9.30	7.20	2.70	0.85	27.67	16.05	0.50
1020	19.83	36.78	9.44	7.27	2.72	0.85	27.42	16.07	0.50
1030	19.78	36.73	9.59	7.34	2.73	0.85	27.53	15.80	0.50
1040	19.73	36.68	9.73	7.41	2.75	0.86	27.78	15.78	0.49
1050	19.67	36.64	9.87	7.49	2.77	0.86	27.92	15.90	0.48
1060	19.61	36.59	10.01	7.56	2.79	0.86	27.89	15.94	0.43
1070	19.55	36.55	10.15	7.63	2.81	0.86	27.87	15.74	0.46
1080	19.49	36.50	10.29	7.71	2.83	0.86	27.93	15.81	0.47
1090	19.43	36.46	10.43	7.79	2.85	0.86	28.03	15.72	0.48
1100	19.36	36.42	10.56	7.85	2.87	0.87	28.09	15.69	0.49
1110	19.30	36.39	10.70	7.93	2.89	0.87	28.12	15.89	0.47
1120	19.23	36.35	10.83	8.01	2.91	0.87	27.99	16.14	0.50
1130	19.16	36.31	10.97	8.10	2.94	0.87	27.76	16.06	0.45
1140	19.10	36.28	11.09	8.18	2.96	0.88	27.67	15.73	0.48
1150	19.03	36.24	11.23	8.26	2.98	0.88	27.90	15.59	0.50
1160	18.97	36.24	11.39	8.35	3.02	0.88	28.19	15.64	0.53
1170	18.90	36.21	11.53	8.43	3.04	0.88	28.09	15.72	0.53
1180	18.83	36.19	11.68	8.52	3.07	0.89	27.91	15.71	0.49
1190	18.76	36.16	11.82	8.60	3.10	0.89	27.94	15.60	0.40
1200	18.69	36.15	11.96	8.69	3.13	0.89	28.02	15.65	0.53
1250	18.32	36.05	12.72	9.19	3.30	0.90	27.83	15.36	0.53
1300	17.93	35.98	13.52	9.77	3.48	0.92	27.48	15.14	0.58
1350	17.51	35.96	14.37	10.43	3.72	0.93	26.91	14.69	0.58
1400	17.06	35.98	15.19	11.18	3.99	0.94	26.60	14.47	0.59
1450	16.56	36.06	15.86	11.94	4.33	0.96	25.55	14.00	0.62
1500	16.00	36.20	16.30	12.62	4.74	0.97	25.16	13.86	0.58

## Typical Performance Data

### Definitions:

Input Return Loss = -S11 (dB)

Gain(Power Gain) = S21 (dB)

Reverse Isolation = -S12 (dB)

Output Return Loss = -S22 (dB)

TEST CONDITIONS: Vd = 4.75V, Id = 47.36mA @ Temperature = +25°C

FREQ	Gain	Isolation	Input Return Loss	Output Return Loss	Stability		IP-3 Output	1dB Comp. Output	Noise Figure
					K	Measure			
(MHz)	(dB)	(dB)	(dB)	(dB)	K	Measure	(dBm)	(dBm)	(dB)
700	19.93	41.21	3.97	5.07	2.79	0.90	23.89	13.58	0.63
800	20.32	38.96	5.76	5.72	2.62	0.85	25.16	14.75	0.55
850	20.34	38.19	6.67	6.07	2.59	0.84	25.62	15.14	0.52
900	20.26	37.60	7.54	6.43	2.59	0.84	26.09	15.39	0.48
910	20.23	37.50	7.70	6.50	2.60	0.84	26.33	15.57	0.43
920	20.20	37.41	7.86	6.57	2.60	0.84	26.43	15.48	0.51
930	20.16	37.32	8.03	6.64	2.61	0.84	26.46	15.56	0.59
940	20.13	37.24	8.19	6.71	2.62	0.84	26.63	15.59	0.55
950	20.09	37.16	8.35	6.79	2.63	0.84	26.77	15.87	0.46
960	20.05	37.09	8.51	6.86	2.64	0.84	26.57	15.92	0.52
970	20.01	37.01	8.66	6.94	2.65	0.85	26.44	15.96	0.42
980	19.96	36.94	8.81	7.00	2.66	0.85	26.72	15.67	0.44
990	19.92	36.87	8.97	7.07	2.67	0.85	27.12	15.58	0.44
1000	19.87	36.81	9.11	7.15	2.69	0.85	27.34	15.81	0.53
1010	19.82	36.75	9.26	7.22	2.70	0.85	27.10	16.20	0.49
1020	19.76	36.70	9.40	7.30	2.72	0.85	26.86	16.19	0.52
1030	19.71	36.64	9.55	7.36	2.73	0.85	27.01	15.97	0.53
1040	19.65	36.59	9.69	7.44	2.75	0.86	27.29	15.98	0.50
1050	19.59	36.54	9.83	7.52	2.77	0.86	27.44	16.05	0.48
1060	19.54	36.51	9.98	7.58	2.79	0.86	27.42	16.10	0.47
1070	19.48	36.46	10.12	7.66	2.81	0.86	27.42	15.97	0.47
1080	19.41	36.42	10.27	7.74	2.83	0.86	27.54	16.00	0.49
1090	19.35	36.38	10.41	7.81	2.85	0.87	27.66	15.93	0.49
1100	19.29	36.34	10.54	7.89	2.87	0.87	27.72	15.92	0.48
1110	19.23	36.31	10.68	7.96	2.89	0.87	27.70	16.11	0.48
1120	19.16	36.28	10.81	8.04	2.92	0.87	27.55	16.31	0.47
1130	19.09	36.24	10.96	8.12	2.94	0.87	27.33	16.23	0.47
1140	19.03	36.20	11.08	8.20	2.96	0.88	27.34	15.95	0.48
1150	18.96	36.16	11.23	8.30	2.99	0.88	27.66	15.90	0.48
1160	18.90	36.16	11.39	8.37	3.02	0.88	27.97	15.95	0.54
1170	18.83	36.14	11.53	8.45	3.05	0.88	27.83	15.97	0.53
1180	18.76	36.11	11.68	8.55	3.08	0.89	27.70	15.95	0.51
1190	18.69	36.09	11.83	8.63	3.10	0.89	27.76	15.85	0.43
1200	18.62	36.07	11.98	8.72	3.14	0.89	27.80	15.94	0.52
1250	18.25	35.98	12.76	9.21	3.30	0.90	27.89	15.63	0.55
1300	17.86	35.91	13.57	9.80	3.49	0.92	27.73	15.40	0.58
1350	17.45	35.90	14.48	10.45	3.73	0.93	27.42	15.02	0.55
1400	16.99	35.91	15.36	11.19	4.00	0.94	27.30	14.76	0.59
1450	16.49	35.99	16.11	11.95	4.33	0.95	26.52	14.28	0.57
1500	15.93	36.13	16.61	12.62	4.75	0.96	26.16	14.06	0.60

## Typical Performance Data

### Definitions:

Input Return Loss = -S11 (dB)

Gain(Power Gain) = S21 (dB)

Reverse Isolation = -S12 (dB)

Output Return Loss = -S22 (dB)

TEST CONDITIONS: Vd = 5.25V, Id = 54.52mA @ Temperature = +25°C

FREQ	Gain	Isolation	Input Return Loss	Output Return Loss	Stability		IP-3 Output	1dB Comp. Output	Noise Figure
					K	Measure			
(MHz)	(dB)	(dB)	(dB)	(dB)	K	Measure	(dBm)	(dBm)	(dB)
700	20.13	41.43	4.08	5.05	2.83	0.89	25.14	13.97	0.56
800	20.49	39.18	5.88	5.69	2.64	0.85	26.25	14.79	0.47
850	20.50	38.39	6.79	6.03	2.61	0.84	26.64	15.01	0.47
900	20.42	37.79	7.64	6.39	2.60	0.84	27.02	15.18	0.46
910	20.38	37.69	7.81	6.46	2.61	0.84	27.16	15.29	0.40
920	20.35	37.59	7.96	6.53	2.61	0.84	27.21	15.20	0.50
930	20.31	37.50	8.12	6.60	2.62	0.84	27.21	15.24	0.52
940	20.27	37.41	8.29	6.67	2.62	0.84	27.36	15.22	0.44
950	20.24	37.34	8.44	6.74	2.63	0.84	27.55	15.40	0.44
960	20.20	37.25	8.59	6.81	2.64	0.84	27.43	15.48	0.48
970	20.15	37.19	8.74	6.89	2.65	0.84	27.22	15.47	0.42
980	20.10	37.11	8.90	6.96	2.67	0.84	27.21	15.22	0.43
990	20.06	37.04	9.04	7.03	2.68	0.85	27.43	15.05	0.43
1000	20.01	36.97	9.19	7.10	2.69	0.85	27.89	15.27	0.47
1010	19.96	36.92	9.33	7.18	2.70	0.85	27.87	15.70	0.46
1020	19.90	36.86	9.46	7.25	2.72	0.85	27.56	15.71	0.48
1030	19.85	36.80	9.61	7.31	2.73	0.85	27.53	15.42	0.51
1040	19.79	36.75	9.75	7.38	2.75	0.85	27.71	15.35	0.45
1050	19.73	36.71	9.89	7.47	2.77	0.86	27.87	15.44	0.45
1060	19.67	36.67	10.02	7.53	2.79	0.86	27.80	15.50	0.45
1070	19.61	36.61	10.17	7.61	2.80	0.86	27.68	15.31	0.44
1080	19.55	36.57	10.30	7.68	2.82	0.86	27.66	15.31	0.47
1090	19.49	36.53	10.44	7.76	2.84	0.86	27.68	15.24	0.43
1100	19.43	36.50	10.56	7.83	2.87	0.87	27.75	15.16	0.50
1110	19.36	36.46	10.70	7.91	2.89	0.87	27.90	15.32	0.46
1120	19.30	36.42	10.83	7.98	2.91	0.87	27.89	15.62	0.45
1130	19.23	36.39	10.97	8.07	2.93	0.87	27.57	15.57	0.45
1140	19.16	36.35	11.09	8.15	2.96	0.88	27.25	15.17	0.46
1150	19.10	36.31	11.23	8.24	2.98	0.88	27.29	15.02	0.44
1160	19.03	36.31	11.38	8.32	3.01	0.88	27.61	15.06	0.50
1170	18.96	36.28	11.52	8.40	3.04	0.88	27.56	15.12	0.54
1180	18.89	36.26	11.65	8.50	3.07	0.89	27.33	15.11	0.53
1190	18.82	36.23	11.79	8.57	3.10	0.89	27.27	15.02	0.41
1200	18.75	36.21	11.93	8.67	3.13	0.89	27.43	15.11	0.50
1250	18.38	36.12	12.67	9.16	3.29	0.90	26.86	14.74	0.52
1300	17.99	36.04	13.43	9.75	3.48	0.92	26.31	14.47	0.59
1350	17.58	36.03	14.24	10.41	3.71	0.93	25.55	14.06	0.55
1400	17.12	36.04	15.02	11.17	3.98	0.95	25.18	13.81	0.57
1450	16.62	36.11	15.62	11.93	4.32	0.96	24.11	13.36	0.60
1500	16.05	36.26	16.00	12.62	4.73	0.97	23.78	13.11	0.54

## Typical Performance Data

### Definitions:

Input Return Loss = -S11 (dB)

Gain(Power Gain) = S21 (dB)

Reverse Isolation = -S12 (dB)

Output Return Loss = -S22 (dB)

TEST CONDITIONS: Vd = 5.00V, Id = 53.00mA @ Temperature = -45°C

FREQ	Gain	Isolation	Input Return Loss	Output Return Loss	Stability		IP-3 Output	1dB Comp. Output	Noise Figure
					K	Measure			
(MHz)	(dB)	(dB)	(dB)	(dB)	K	Measure	(dBm)	(dBm)	(dB)
700	20.62	41.43	3.97	4.75	2.61	0.86	24.40	13.78	0.36
800	20.97	39.11	5.66	5.44	2.45	0.83	25.77	15.33	0.33
850	20.99	38.29	6.53	5.86	2.42	0.83	26.27	15.82	0.30
900	20.94	37.63	7.33	6.22	2.40	0.83	26.80	16.19	0.31
910	20.91	37.53	7.49	6.28	2.40	0.83	27.05	16.35	0.22
920	20.88	37.43	7.63	6.34	2.41	0.83	27.18	16.29	0.32
930	20.85	37.33	7.78	6.40	2.41	0.83	27.21	16.36	0.40
940	20.81	37.24	7.93	6.46	2.41	0.83	27.40	16.42	0.30
950	20.77	37.16	8.07	6.53	2.42	0.83	27.54	16.61	0.27
960	20.73	37.08	8.22	6.58	2.43	0.83	27.30	16.71	0.29
970	20.69	37.00	8.36	6.64	2.43	0.83	27.18	16.72	0.22
980	20.64	36.92	8.50	6.70	2.44	0.83	27.49	16.47	0.27
990	20.60	36.84	8.64	6.74	2.44	0.83	28.00	16.43	0.27
1000	20.55	36.78	8.77	6.80	2.45	0.83	28.13	16.70	0.31
1010	20.50	36.71	8.91	6.86	2.46	0.83	27.82	17.04	0.29
1020	20.44	36.66	9.05	6.92	2.48	0.83	27.58	16.99	0.31
1030	20.39	36.59	9.18	6.97	2.48	0.84	27.75	16.81	0.34
1040	20.34	36.54	9.31	7.02	2.50	0.84	28.02	16.79	0.28
1050	20.28	36.49	9.44	7.09	2.51	0.84	28.17	16.90	0.31
1060	20.22	36.44	9.58	7.14	2.53	0.84	28.18	16.91	0.27
1070	20.17	36.39	9.71	7.21	2.54	0.84	28.22	16.80	0.27
1080	20.11	36.34	9.84	7.27	2.56	0.84	28.37	16.83	0.30
1090	20.05	36.28	9.98	7.34	2.57	0.85	28.52	16.76	0.27
1100	19.99	36.25	10.10	7.41	2.59	0.85	28.62	16.77	0.33
1110	19.93	36.20	10.23	7.47	2.61	0.85	28.63	16.94	0.27
1120	19.87	36.17	10.36	7.54	2.63	0.85	28.40	17.13	0.29
1130	19.80	36.12	10.50	7.62	2.64	0.85	28.15	17.04	0.30
1140	19.74	36.09	10.62	7.70	2.66	0.86	28.18	16.80	0.30
1150	19.68	36.04	10.75	7.78	2.68	0.86	28.55	16.66	0.30
1160	19.62	36.03	10.90	7.86	2.70	0.86	28.92	16.68	0.36
1170	19.55	36.00	11.05	7.93	2.73	0.86	28.83	16.79	0.36
1180	19.49	35.96	11.19	8.02	2.75	0.87	28.72	16.73	0.37
1190	19.42	35.93	11.34	8.09	2.77	0.87	28.81	16.65	0.24
1200	19.36	35.90	11.47	8.19	2.80	0.87	28.81	16.77	0.34
1250	19.01	35.77	12.23	8.68	2.93	0.89	28.98	16.40	0.36
1300	18.65	35.66	12.99	9.28	3.08	0.90	29.01	16.22	0.40
1350	18.27	35.63	13.76	9.99	3.28	0.92	28.92	15.84	0.36
1400	17.84	35.59	14.42	10.81	3.49	0.94	29.12	15.59	0.38
1450	17.37	35.64	14.89	11.67	3.77	0.95	28.61	15.10	0.41
1500	16.83	35.75	15.13	12.47	4.11	0.97	28.49	14.91	0.36

## Typical Performance Data

### Definitions:

Input Return Loss = -S11 (dB)

Gain(Power Gain) = S21 (dB)

Reverse Isolation = -S12 (dB)

Output Return Loss = -S22 (dB)

TEST CONDITIONS: Vd = 4.75V, Id = 45.61mA @ Temperature = -45°C

FREQ	Gain	Isolation	Input Return Loss	Output Return Loss	Stability		IP-3 Output	1dB Comp. Output	Noise Figure
					K	Measure			
(MHz)	(dB)	(dB)	(dB)	(dB)			(dBm)	(dBm)	(dB)
700	20.41	41.35	3.87	4.77	2.61	0.87	23.57	13.54	0.38
800	20.79	39.05	5.56	5.46	2.45	0.84	24.89	15.28	0.36
850	20.82	38.23	6.43	5.88	2.43	0.83	25.37	15.79	0.34
900	20.77	37.58	7.25	6.24	2.41	0.83	25.89	16.21	0.32
910	20.75	37.47	7.41	6.31	2.41	0.83	26.15	16.34	0.23
920	20.72	37.37	7.56	6.37	2.42	0.83	26.28	16.34	0.32
930	20.68	37.28	7.72	6.44	2.42	0.83	26.31	16.37	0.39
940	20.65	37.19	7.87	6.50	2.42	0.83	26.49	16.45	0.30
950	20.61	37.11	8.02	6.56	2.43	0.83	26.63	16.64	0.29
960	20.57	37.02	8.17	6.62	2.44	0.83	26.39	16.74	0.34
970	20.53	36.95	8.32	6.67	2.44	0.83	26.27	16.74	0.25
980	20.48	36.88	8.46	6.73	2.45	0.83	26.61	16.50	0.28
990	20.44	36.80	8.61	6.78	2.46	0.83	27.09	16.45	0.24
1000	20.39	36.73	8.74	6.84	2.47	0.83	27.22	16.74	0.31
1010	20.34	36.67	8.89	6.89	2.48	0.83	26.93	17.05	0.25
1020	20.29	36.60	9.03	6.95	2.49	0.84	26.68	16.99	0.33
1030	20.24	36.54	9.16	7.01	2.50	0.84	26.86	16.82	0.35
1040	20.18	36.49	9.31	7.07	2.51	0.84	27.13	16.82	0.31
1050	20.13	36.44	9.44	7.13	2.53	0.84	27.28	16.92	0.27
1060	20.07	36.40	9.58	7.18	2.54	0.84	27.29	16.91	0.32
1070	20.02	36.35	9.72	7.25	2.56	0.84	27.34	16.82	0.28
1080	19.96	36.30	9.86	7.31	2.57	0.84	27.48	16.83	0.30
1090	19.90	36.25	10.00	7.38	2.59	0.85	27.65	16.78	0.27
1100	19.84	36.21	10.13	7.44	2.61	0.85	27.76	16.80	0.31
1110	19.78	36.17	10.27	7.51	2.63	0.85	27.72	16.97	0.29
1120	19.72	36.13	10.41	7.59	2.65	0.85	27.51	17.13	0.30
1130	19.65	36.09	10.55	7.66	2.66	0.86	27.26	17.04	0.30
1140	19.59	36.05	10.68	7.74	2.68	0.86	27.30	16.83	0.29
1150	19.53	36.00	10.82	7.82	2.70	0.86	27.69	16.68	0.28
1160	19.47	35.99	10.98	7.90	2.73	0.86	28.03	16.70	0.35
1170	19.41	35.96	11.13	7.98	2.75	0.87	27.94	16.80	0.34
1180	19.34	35.93	11.28	8.07	2.77	0.87	27.82	16.75	0.30
1190	19.28	35.90	11.44	8.14	2.80	0.87	27.92	16.66	0.25
1200	19.21	35.87	11.58	8.24	2.82	0.87	27.94	16.78	0.34
1250	18.87	35.74	12.38	8.73	2.95	0.89	28.14	16.39	0.35
1300	18.51	35.64	13.21	9.33	3.11	0.90	28.20	16.23	0.38
1350	18.13	35.60	14.06	10.04	3.31	0.92	28.14	15.86	0.36
1400	17.70	35.58	14.83	10.86	3.53	0.94	28.37	15.64	0.38
1450	17.23	35.62	15.43	11.72	3.80	0.95	27.95	15.15	0.41
1500	16.69	35.73	15.79	12.51	4.14	0.96	27.90	14.98	0.38

## Typical Performance Data

### Definitions:

Input Return Loss = -S11 (dB)

Gain(Power Gain) = S21 (dB)

Reverse Isolation = -S12 (dB)

Output Return Loss = -S22 (dB)

TEST CONDITIONS: Vd = 5.25V, Id = 54.05mA @ Temperature = -45°C

FREQ	Gain	Isolation	Input Return Loss	Output Return Loss	Stability		IP-3 Output	1dB Comp. Output	Noise Figure
					K	Measure			
(MHz)	(dB)	(dB)	(dB)	(dB)	K	Measure	(dBm)	(dBm)	(dB)
700	20.63	41.49	3.99	4.75	2.62	0.86	25.24	14.30	0.38
800	20.97	39.18	5.68	5.44	2.45	0.83	26.61	15.55	0.32
850	21.00	38.35	6.54	5.85	2.42	0.83	27.10	15.95	0.32
900	20.94	37.69	7.35	6.21	2.40	0.83	27.63	16.29	0.28
910	20.91	37.58	7.51	6.28	2.40	0.83	27.85	16.41	0.24
920	20.88	37.48	7.65	6.34	2.40	0.83	27.98	16.34	0.30
930	20.85	37.38	7.80	6.40	2.40	0.83	28.04	16.39	0.35
940	20.81	37.29	7.95	6.46	2.40	0.83	28.24	16.45	0.27
950	20.77	37.20	8.09	6.52	2.41	0.83	28.35	16.65	0.27
960	20.73	37.12	8.24	6.58	2.42	0.83	28.12	16.72	0.28
970	20.69	37.04	8.38	6.64	2.42	0.83	27.98	16.76	0.24
980	20.64	36.97	8.52	6.69	2.43	0.83	28.31	16.46	0.28
990	20.60	36.89	8.66	6.74	2.43	0.83	28.79	16.38	0.22
1000	20.55	36.83	8.80	6.79	2.44	0.83	28.95	16.65	0.33
1010	20.50	36.76	8.94	6.86	2.45	0.83	28.64	17.03	0.30
1020	20.44	36.69	9.06	6.91	2.46	0.83	28.35	17.01	0.29
1030	20.39	36.63	9.19	6.97	2.47	0.84	28.51	16.78	0.33
1040	20.34	36.57	9.33	7.02	2.49	0.84	28.80	16.78	0.30
1050	20.28	36.53	9.46	7.09	2.50	0.84	28.95	16.85	0.28
1060	20.22	36.48	9.60	7.14	2.52	0.84	28.96	16.89	0.24
1070	20.17	36.42	9.73	7.20	2.53	0.84	29.00	16.75	0.26
1080	20.10	36.37	9.86	7.27	2.54	0.84	29.14	16.77	0.31
1090	20.05	36.33	10.00	7.34	2.56	0.85	29.30	16.72	0.27
1100	19.99	36.29	10.12	7.40	2.57	0.85	29.44	16.71	0.32
1110	19.93	36.24	10.26	7.47	2.59	0.85	29.42	16.90	0.30
1120	19.86	36.20	10.38	7.54	2.61	0.85	29.20	17.10	0.30
1130	19.80	36.17	10.52	7.62	2.63	0.85	28.90	17.01	0.25
1140	19.73	36.12	10.64	7.70	2.65	0.86	28.93	16.75	0.28
1150	19.67	36.07	10.78	7.77	2.66	0.86	29.31	16.59	0.29
1160	19.62	36.06	10.92	7.85	2.69	0.86	29.64	16.62	0.36
1170	19.55	36.03	11.07	7.93	2.71	0.87	29.59	16.71	0.34
1180	19.48	36.00	11.21	8.02	2.73	0.87	29.46	16.68	0.34
1190	19.42	35.97	11.35	8.10	2.76	0.87	29.52	16.59	0.23
1200	19.35	35.94	11.50	8.19	2.78	0.87	29.57	16.68	0.30
1250	19.01	35.80	12.25	8.68	2.91	0.89	29.68	16.34	0.35
1300	18.65	35.70	13.02	9.29	3.06	0.91	29.69	16.13	0.38
1350	18.27	35.65	13.77	10.00	3.25	0.92	29.54	15.74	0.33
1400	17.84	35.62	14.43	10.82	3.47	0.94	29.64	15.48	0.37
1450	17.37	35.67	14.89	11.68	3.74	0.96	28.93	14.99	0.37
1500	16.83	35.78	15.13	12.48	4.08	0.97	28.65	14.80	0.36

## Typical Performance Data

### Definitions:

Input Return Loss = -S11 (dB)

Gain(Power Gain) = S21 (dB)

Reverse Isolation = -S12 (dB)

Output Return Loss = -S22 (dB)

TEST CONDITIONS: Vd = 5.00V, Id = 49.62mA @ Temperature = +85°C

FREQ	Gain	Isolation	Input Return Loss	Output Return Loss	Stability		IP-3 Output	1dB Comp. Output	Noise Figure
					K	Measure			
(MHz)	(dB)	(dB)	(dB)	(dB)	K	Measure	(dBm)	(dBm)	(dB)
700	19.45	41.34	4.00	5.22	3.01	0.92	23.08	12.07	0.73
800	19.88	39.13	5.78	5.87	2.82	0.87	23.86	12.86	0.69
850	19.90	38.38	6.68	6.24	2.79	0.86	24.06	13.10	0.65
900	19.81	37.82	7.55	6.64	2.81	0.86	24.28	13.29	0.63
910	19.78	37.73	7.72	6.72	2.82	0.86	24.34	13.37	0.57
920	19.75	37.64	7.89	6.80	2.83	0.86	24.36	13.27	0.67
930	19.71	37.56	8.05	6.89	2.84	0.86	24.33	13.32	0.73
940	19.67	37.48	8.22	6.96	2.85	0.86	24.43	13.30	0.63
950	19.63	37.41	8.38	7.04	2.87	0.86	24.63	13.48	0.62
960	19.59	37.34	8.54	7.12	2.88	0.86	24.59	13.53	0.66
970	19.55	37.27	8.70	7.20	2.90	0.87	24.36	13.57	0.58
980	19.50	37.20	8.85	7.28	2.91	0.87	24.18	13.31	0.64
990	19.45	37.14	9.01	7.36	2.93	0.87	24.28	13.18	0.58
1000	19.40	37.08	9.16	7.43	2.95	0.87	24.81	13.31	0.69
1010	19.35	37.03	9.31	7.51	2.96	0.87	24.94	13.80	0.64
1020	19.29	36.98	9.46	7.59	2.98	0.87	24.64	13.81	0.65
1030	19.23	36.93	9.61	7.65	3.00	0.87	24.50	13.54	0.66
1040	19.18	36.88	9.77	7.73	3.03	0.87	24.60	13.49	0.64
1050	19.11	36.84	9.91	7.81	3.05	0.88	24.74	13.58	0.65
1060	19.05	36.81	10.06	7.88	3.08	0.88	24.65	13.63	0.61
1070	18.99	36.77	10.21	7.96	3.10	0.88	24.51	13.47	0.62
1080	18.92	36.73	10.36	8.04	3.13	0.88	24.46	13.49	0.63
1090	18.86	36.70	10.51	8.11	3.15	0.88	24.45	13.39	0.62
1100	18.79	36.67	10.64	8.18	3.18	0.88	24.50	13.36	0.62
1110	18.73	36.64	10.79	8.26	3.21	0.89	24.67	13.51	0.64
1120	18.66	36.61	10.93	8.33	3.24	0.89	24.72	13.77	0.64
1130	18.58	36.59	11.08	8.41	3.27	0.89	24.45	13.68	0.61
1140	18.52	36.56	11.22	8.49	3.29	0.89	24.11	13.37	0.64
1150	18.45	36.53	11.37	8.57	3.33	0.89	24.09	13.26	0.64
1160	18.38	36.53	11.54	8.65	3.36	0.89	24.32	13.33	0.72
1170	18.30	36.50	11.69	8.72	3.40	0.90	24.29	13.31	0.70
1180	18.23	36.48	11.86	8.81	3.43	0.90	24.10	13.18	0.66
1190	18.16	36.47	12.01	8.89	3.47	0.90	24.05	13.18	0.57
1200	18.08	36.46	12.17	8.98	3.51	0.90	24.18	13.26	0.68
1250	17.69	36.40	13.01	9.45	3.71	0.91	23.64	12.91	0.71
1300	17.28	36.35	13.89	9.99	3.94	0.92	23.22	12.68	0.78
1350	16.85	36.38	14.85	10.60	4.23	0.93	22.71	12.27	0.72
1400	16.37	36.42	15.84	11.26	4.56	0.94	22.46	11.98	0.79
1450	15.85	36.53	16.70	11.94	4.97	0.95	21.87	11.54	0.80
1500	15.26	36.69	17.32	12.49	5.48	0.96	21.66	11.42	0.75

## Typical Performance Data

### Definitions:

Input Return Loss = -S11 (dB)

Gain(Power Gain) = S21 (dB)

Reverse Isolation = -S12 (dB)

Output Return Loss = -S22 (dB)

TEST CONDITIONS: Vd = 4.75V, Id = 45.20mA @ Temperature = +85°C

FREQ	Gain	Isolation	Input Return Loss	Output Return Loss	Stability		IP-3 Output	1dB Comp. Output	Noise Figure
					K	Measure			
(MHz)	(dB)	(dB)	(dB)	(dB)	K	Measure	(dBm)	(dBm)	(dB)
700	19.28	41.18	3.89	5.22	2.97	0.92	22.77	11.90	0.76
800	19.73	38.98	5.65	5.87	2.79	0.87	23.74	12.86	0.65
850	19.76	38.24	6.55	6.25	2.77	0.86	24.04	13.24	0.63
900	19.69	37.68	7.42	6.66	2.80	0.86	24.35	13.43	0.65
910	19.65	37.59	7.59	6.74	2.81	0.86	24.49	13.57	0.57
920	19.63	37.51	7.76	6.82	2.82	0.86	24.53	13.52	0.64
930	19.59	37.43	7.93	6.91	2.83	0.86	24.52	13.53	0.74
940	19.55	37.35	8.10	6.98	2.84	0.87	24.66	13.55	0.66
950	19.51	37.27	8.26	7.06	2.86	0.87	24.84	13.75	0.63
960	19.47	37.22	8.42	7.14	2.88	0.87	24.73	13.81	0.66
970	19.43	37.15	8.58	7.22	2.89	0.87	24.54	13.86	0.55
980	19.38	37.08	8.74	7.30	2.91	0.87	24.55	13.56	0.62
990	19.33	37.02	8.89	7.38	2.92	0.87	24.75	13.44	0.57
1000	19.28	36.96	9.05	7.46	2.94	0.87	25.18	13.73	0.66
1010	19.23	36.91	9.20	7.53	2.96	0.87	25.17	14.06	0.66
1020	19.17	36.86	9.35	7.61	2.98	0.87	24.90	14.08	0.67
1030	19.12	36.82	9.50	7.68	3.00	0.88	24.86	13.87	0.69
1040	19.06	36.77	9.66	7.75	3.02	0.88	25.03	13.95	0.66
1050	19.00	36.73	9.81	7.84	3.05	0.88	25.17	13.93	0.63
1060	18.94	36.69	9.97	7.91	3.07	0.88	25.11	13.95	0.64
1070	18.88	36.66	10.11	7.99	3.10	0.88	25.01	13.87	0.61
1080	18.81	36.63	10.27	8.06	3.13	0.88	25.01	13.86	0.66
1090	18.75	36.59	10.41	8.14	3.15	0.88	25.04	13.74	0.62
1100	18.68	36.56	10.56	8.21	3.18	0.89	25.08	13.78	0.61
1110	18.62	36.54	10.71	8.28	3.21	0.89	25.19	13.94	0.63
1120	18.55	36.51	10.86	8.36	3.24	0.89	25.17	14.16	0.67
1130	18.48	36.49	11.01	8.43	3.27	0.89	24.92	14.10	0.62
1140	18.41	36.45	11.15	8.52	3.30	0.89	24.69	13.82	0.65
1150	18.34	36.42	11.31	8.60	3.33	0.89	24.78	13.68	0.64
1160	18.27	36.43	11.47	8.67	3.37	0.89	25.04	13.75	0.69
1170	18.20	36.40	11.63	8.76	3.40	0.90	24.97	13.78	0.72
1180	18.12	36.39	11.80	8.84	3.44	0.90	24.79	13.85	0.71
1190	18.05	36.38	11.95	8.91	3.48	0.90	24.78	13.74	0.57
1200	17.97	36.36	12.12	9.01	3.51	0.90	24.89	13.77	0.69
1250	17.59	36.31	12.98	9.47	3.72	0.91	24.48	13.52	0.71
1300	17.18	36.27	13.90	10.02	3.95	0.92	24.10	13.21	0.78
1350	16.74	36.31	14.92	10.62	4.25	0.93	23.59	12.83	0.72
1400	16.27	36.34	15.97	11.29	4.58	0.94	23.35	12.68	0.75
1450	15.75	36.45	16.96	11.94	4.99	0.95	22.71	12.27	0.77
1500	15.16	36.63	17.72	12.51	5.51	0.96	22.45	12.10	0.78



## Typical Performance Data

### Definitions:

Input Return Loss = -S11 (dB)

Gain(Power Gain) = S21 (dB)

Reverse Isolation = -S12 (dB)

Output Return Loss = -S22 (dB)

TEST CONDITIONS: Vd = 5.25V, Id = 54.25mA @ Temperature = +85°C

FREQ	Gain	Isolation	Input Return Loss	Output Return Loss	Stability		IP-3 Output	1dB Comp. Output	Noise Figure
					K	Measure			
(MHz)	(dB)	(dB)	(dB)	(dB)	K	Measure	(dBm)	(dBm)	(dB)
700	19.56	41.51	4.08	5.23	3.05	0.91	22.99	12.03	0.70
800	19.96	39.29	5.87	5.87	2.85	0.87	23.49	12.64	0.71
850	19.98	38.52	6.77	6.23	2.82	0.86	23.55	12.85	0.67
900	19.89	37.96	7.63	6.63	2.84	0.86	23.65	12.95	0.64
910	19.85	37.86	7.80	6.72	2.84	0.86	23.66	12.91	0.54
920	19.82	37.77	7.97	6.79	2.85	0.86	23.64	12.84	0.64
930	19.79	37.70	8.13	6.87	2.86	0.86	23.61	12.86	0.78
940	19.74	37.61	8.30	6.95	2.87	0.86	23.68	12.84	0.62
950	19.71	37.55	8.46	7.03	2.89	0.86	23.87	13.06	0.60
960	19.66	37.48	8.62	7.10	2.90	0.86	23.90	13.19	0.64
970	19.62	37.40	8.77	7.19	2.91	0.86	23.64	13.19	0.55
980	19.57	37.33	8.92	7.27	2.93	0.87	23.35	12.79	0.59
990	19.52	37.28	9.07	7.34	2.95	0.87	23.37	12.63	0.58
1000	19.47	37.21	9.22	7.42	2.96	0.87	23.92	12.89	0.68
1010	19.42	37.16	9.37	7.50	2.98	0.87	24.14	13.26	0.61
1020	19.36	37.10	9.52	7.57	3.00	0.87	23.85	13.28	0.63
1030	19.30	37.06	9.66	7.64	3.02	0.87	23.63	13.02	0.68
1040	19.25	37.01	9.81	7.71	3.04	0.87	23.69	12.97	0.63
1050	19.18	36.96	9.96	7.79	3.06	0.88	23.81	13.09	0.63
1060	19.12	36.93	10.11	7.86	3.09	0.88	23.73	13.09	0.63
1070	19.06	36.89	10.25	7.93	3.11	0.88	23.57	13.01	0.58
1080	18.99	36.85	10.40	8.01	3.14	0.88	23.49	12.96	0.61
1090	18.93	36.82	10.54	8.09	3.16	0.88	23.45	12.85	0.64
1100	18.86	36.79	10.67	8.16	3.19	0.88	23.50	12.73	0.65
1110	18.79	36.75	10.82	8.23	3.22	0.89	23.69	12.94	0.63
1120	18.72	36.72	10.95	8.31	3.25	0.89	23.79	13.15	0.62
1130	18.65	36.70	11.10	8.39	3.28	0.89	23.52	13.09	0.62
1140	18.58	36.67	11.24	8.46	3.31	0.89	23.15	12.79	0.63
1150	18.51	36.64	11.39	8.54	3.34	0.89	23.08	12.52	0.64
1160	18.44	36.64	11.55	8.62	3.37	0.89	23.27	12.56	0.69
1170	18.36	36.62	11.70	8.70	3.41	0.90	23.27	12.55	0.67
1180	18.29	36.59	11.86	8.79	3.44	0.90	23.09	12.63	0.71
1190	18.22	36.58	12.00	8.86	3.48	0.90	23.02	12.50	0.56
1200	18.14	36.56	12.17	8.95	3.52	0.90	23.16	12.55	0.62
1250	17.75	36.51	12.97	9.41	3.72	0.91	22.61	12.20	0.70
1300	17.34	36.46	13.82	9.96	3.95	0.92	22.23	11.89	0.74
1350	16.91	36.48	14.72	10.55	4.24	0.93	21.77	11.44	0.74
1400	16.43	36.52	15.63	11.22	4.57	0.94	21.55	11.12	0.77
1450	15.91	36.62	16.39	11.89	4.98	0.95	21.07	10.80	0.76
1500	15.31	36.79	16.92	12.47	5.48	0.96	20.90	10.35	0.78

## Typical Performance Curves

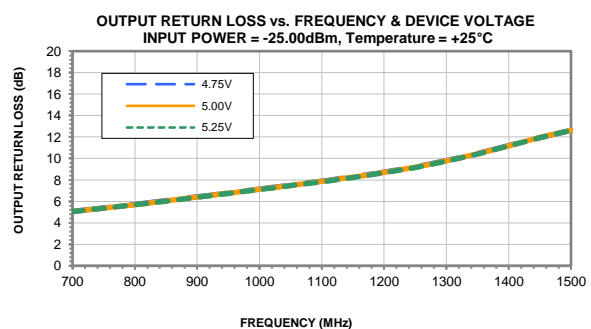
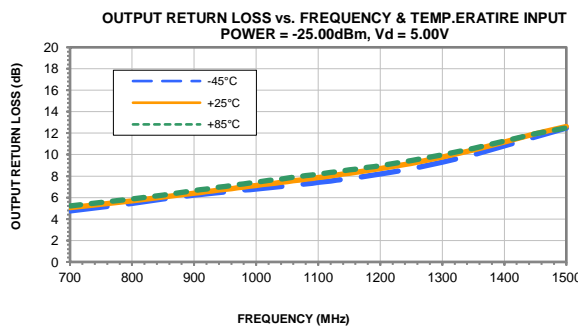
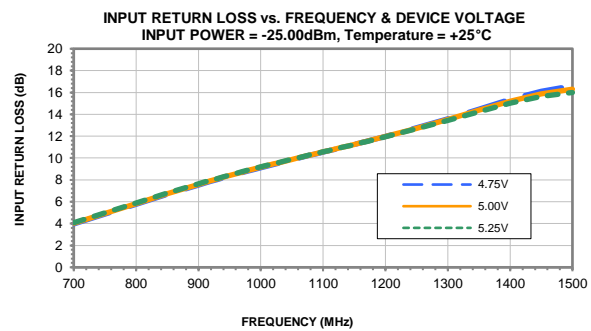
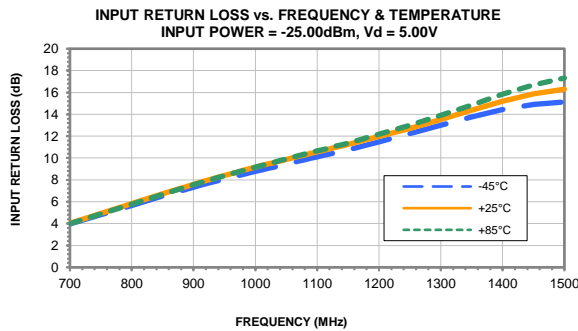
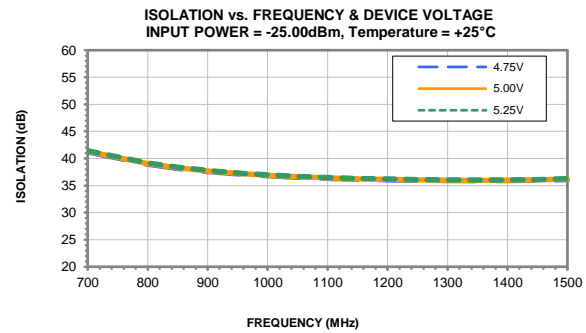
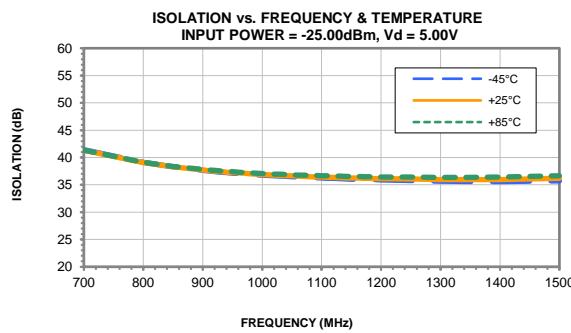
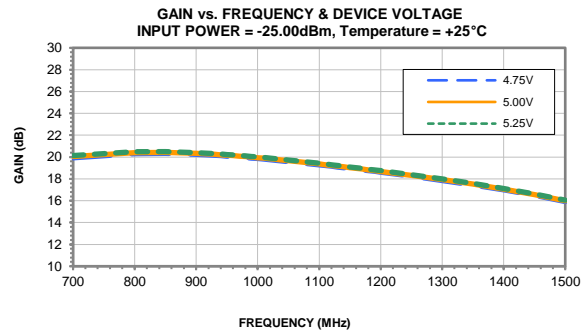
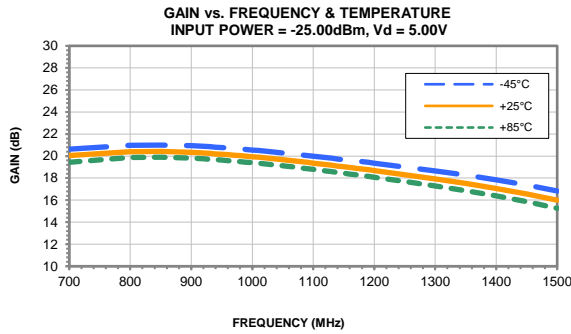

## Typical Performance Curves

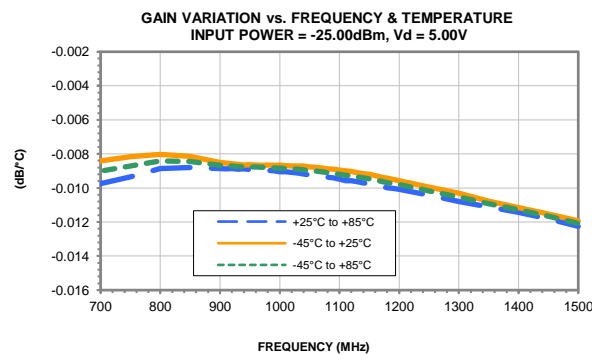
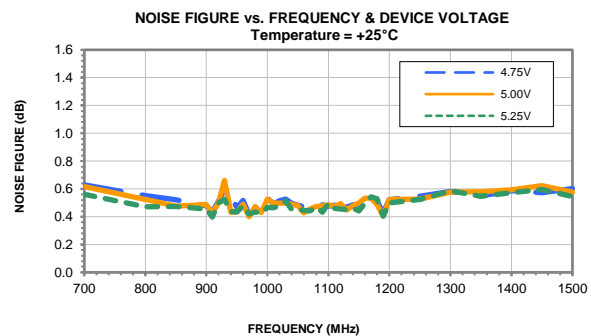
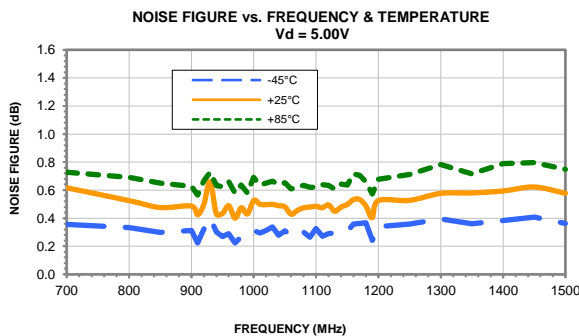
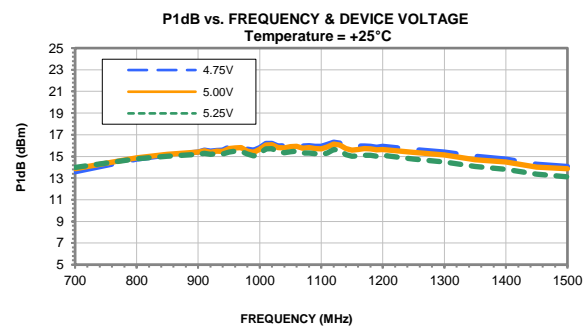
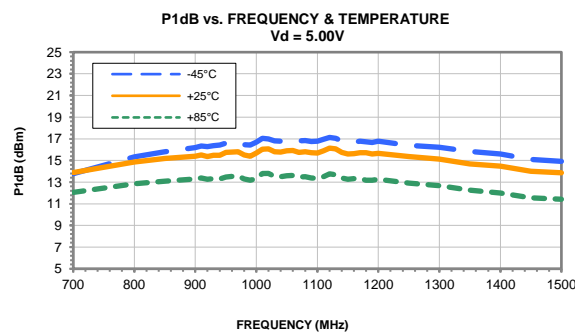
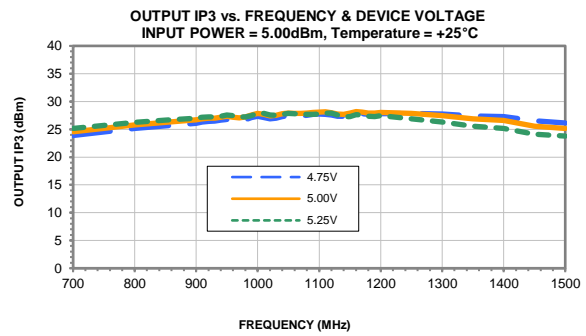
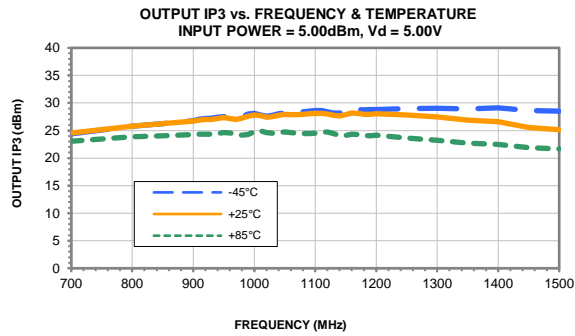

### Outline Dimensions

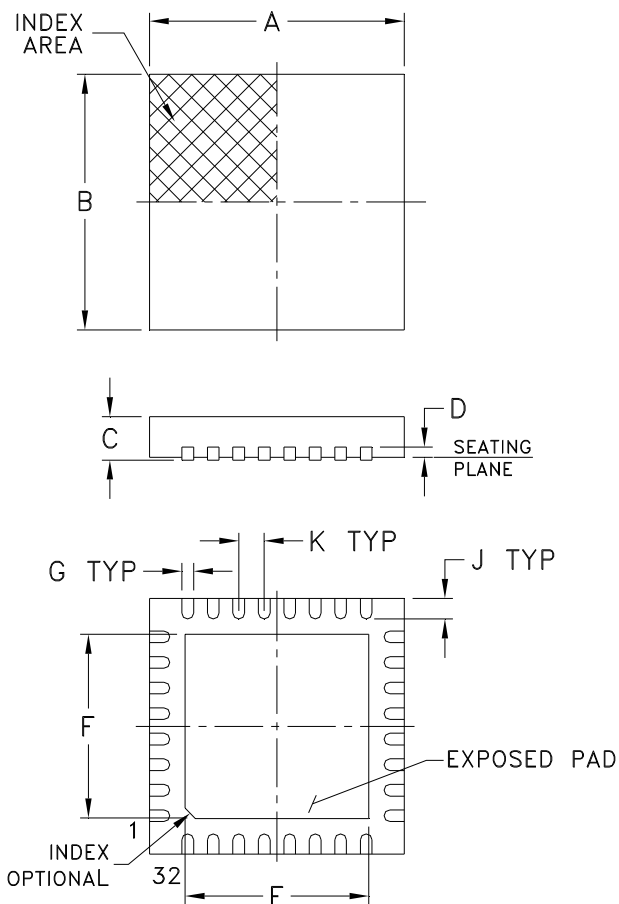

### PCB Land Pattern

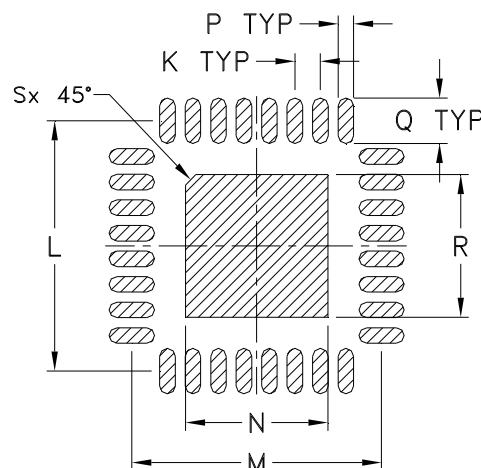

Suggested Layout,  
Tolerance to be within  $\pm .002$

CASE #	A	B	C MAX	C MIN	D	E	F	G	H	J
DG1677-2	.197 (5.00)	.197 (5.00)	.039 (1.00)	.031 (0.80)	.008 (0.20)	.142 (3.60)	.142 (3.60)	.009 (0.23)	- -	.016 (0.40)
CASE #	K	L	M	N	P	Q	R	S	WT. GRAM	
DG1677-2	.020 (0.50)	.193 (4.90)	.193 (4.90)	.110 (2.79)	.012 (0.30)	.035 (0.89)	.110 (2.79)	.008 (0.20)	.05	

Dimensions are in inches (mm). Tolerances: 2 Pl.  $\pm .01$ ; 3 Pl.  $\pm .005$

#### Notes:

- Case material: Plastic.
- Termination finish:

For RoHS Case Styles: Tin-Silver alloy plate over Nickel barrier transitioning to Matte-Tin.  
All models, (+) suffix. See Data sheet.

For RoHS-5 Case Styles: Tin-Lead plate. All models, no (+) suffix.

# Tape & Reel Packaging TR-F68

## DEVICE ORIENTATION IN T&R

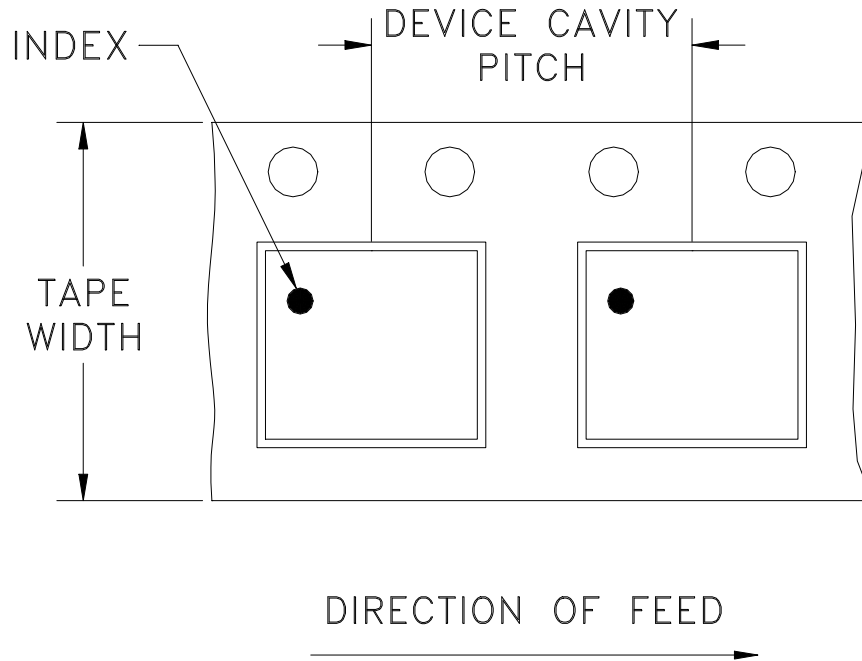

Tape Width, mm	Device Cavity Pitch, mm	Reel Size, inches	Devices per Reel see note	
12	8	7	Small quantity standard	20
				50
				100
				200
				500
		7	Standard	1000
		13	Standard	2000
3000				
				4000

Mini-Circuits carrier tape materials provide protection from ESD (Electro-Static Discharge) during handling and transportation. Tapes are static dissipative and comply with industry standards EIA-481/EIA-541.

Go to: [www.minicircuits.com/pages/pdfs/tape.pdf](http://www.minicircuits.com/pages/pdfs/tape.pdf)



INTERNET <http://www.minicircuits.com>

P.O. Box 350166, Brooklyn, New York 11235-0003 (718) 934-4500 Fax (718) 332-4661

Distribution Centers NORTH AMERICA 800-654-7949 • 417-335-5935 • Fax 417-335-5945 • EUROPE 44-1252-832600 • Fax 44-1252-837010

Mini-Circuits ISO 9001 & ISO 14001 Certified

THIRD ANGLE PROJECTION

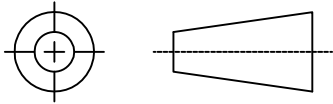

REVISIONS

REV	ECN No.	DESCRIPTION	DATE	DR	AUTH
OR	ECO-000829	NEW RELEASE	12/06/19	ITG	DH

SUGGESTED MOUNTING CONFIGURATION  
FOR DG1677-2 CASE STYLE

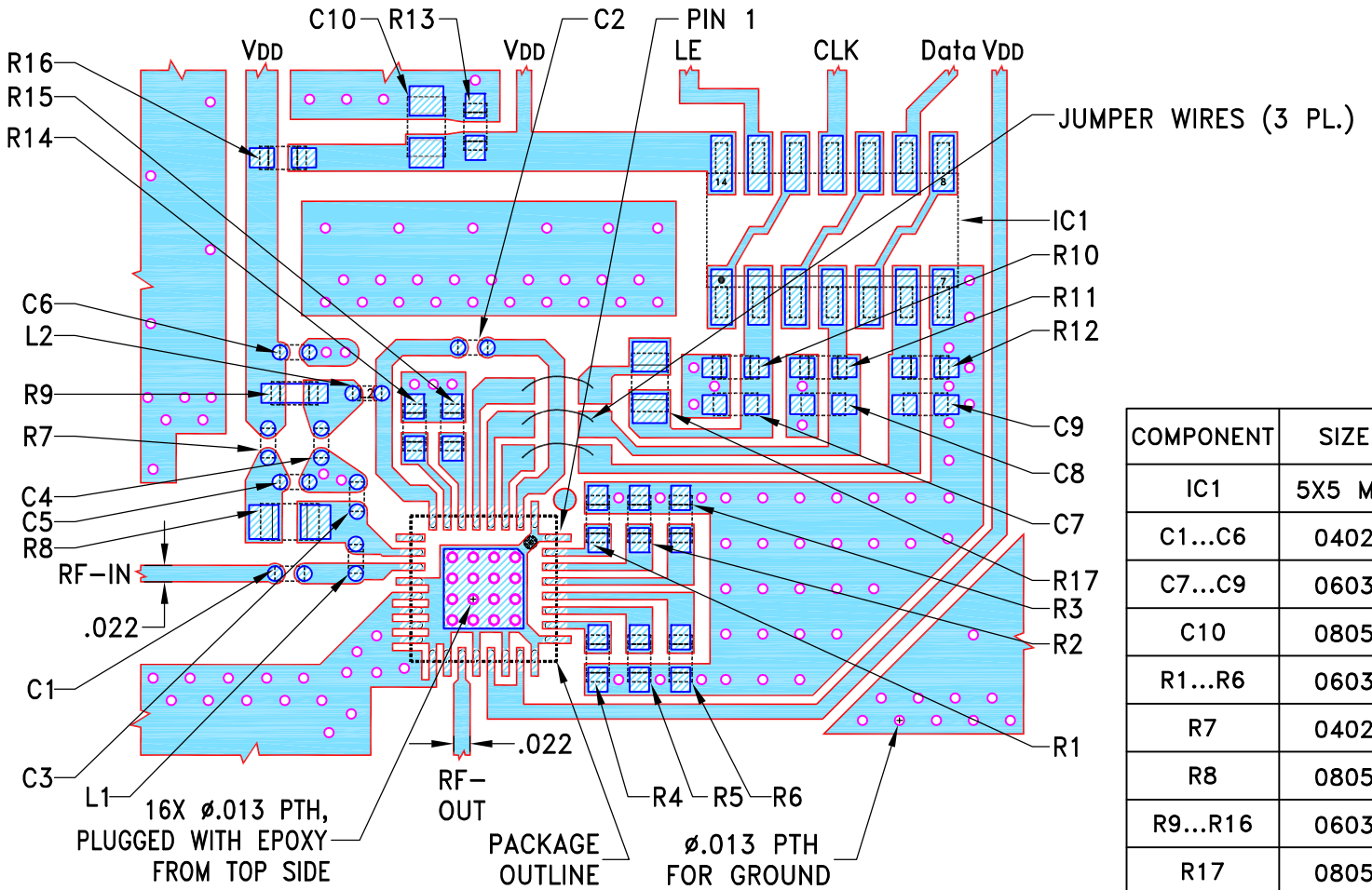

COMPONENT	SIZE
IC1	5X5 MM
C1...C6	0402
C7...C9	0603
C10	0805
R1...R6	0603
R7	0402
R8	0805
R9...R16	0603
R17	0805
L1,L2	0402

NOTES:

1. TRACE WIDTH IS SHOWN FOR ROGERS R04350B WITH DIELECTRIC THICKNESS  $.010 \pm .001$ "; COPPER: 1/2 OZ. EACH SIDE. FOR OTHER MATERIALS TRACE WIDTH MAY NEED TO BE MODIFIED.
2. CHIP COMPONENT FOOT PRINTS SHOWN FOR REFERENCE. FOR COMPONENT VALUES REFER TO TB-DVGA3-122+.
3. BOTTOM SIDE OF THE PCB IS CONTINUOUS GROUND PLANE.

- DENOTES PCB COPPER LAYOUT WITH SMOBC (SOLDER MASK OVER BARE COPPER).
- DENOTES COPPER LAND PATTERN FREE OF SOLDER MASK.

UNLESS OTHERWISE SPECIFIED	INITIALS	DATE
DIMENSIONS ARE IN INCHES	DRAWN ITG	12/06/19
TOLERANCES ON:	CHECKED GF	12/06/19
2 PL DECIMALS ±	APPROVED DH	12/06/19
3 PL DECIMALS ± .005		
ANGLES ±		
FRACTIONS ±		

**Mini-Circuits®** 13 Neptune Avenue  
Brooklyn NY 11235

PL, DG1677-2, TB-DVGA3-122+

SIZE	CODE IDENT	DRAWING NO:	REV:
A	15542	98-PL-655	OR
FILE:	98PL655	SCALE: 4:1	SHEET: 1 OF 1

Mini-Circuits®  
THIS DOCUMENT AND ITS CONTENTS ARE THE PROPERTY OF MINI-CIRCUITS. EXCEPT FOR USE EXPRESSLY GRANTED, IN WRITING, TO ITS VENDORS, VENDEE AND THE UNITED STATES GOVERNMENT, MINI-CIRCUITS RESERVES ALL PROPRIETARY DESIGN, USE, MANUFACTURING AND REPRODUCTION RIGHTS THERETO. THESE CONTENTS SHALL NOT BE USED, DUPLICATED OR DISCLOSED TO ANY OUTSIDE PARTY, IN WHOLE OR IN PART, WITHOUT WRITTEN PERMISSION OF MINI-CIRCUITS.

# Evaluation Board and Circuit

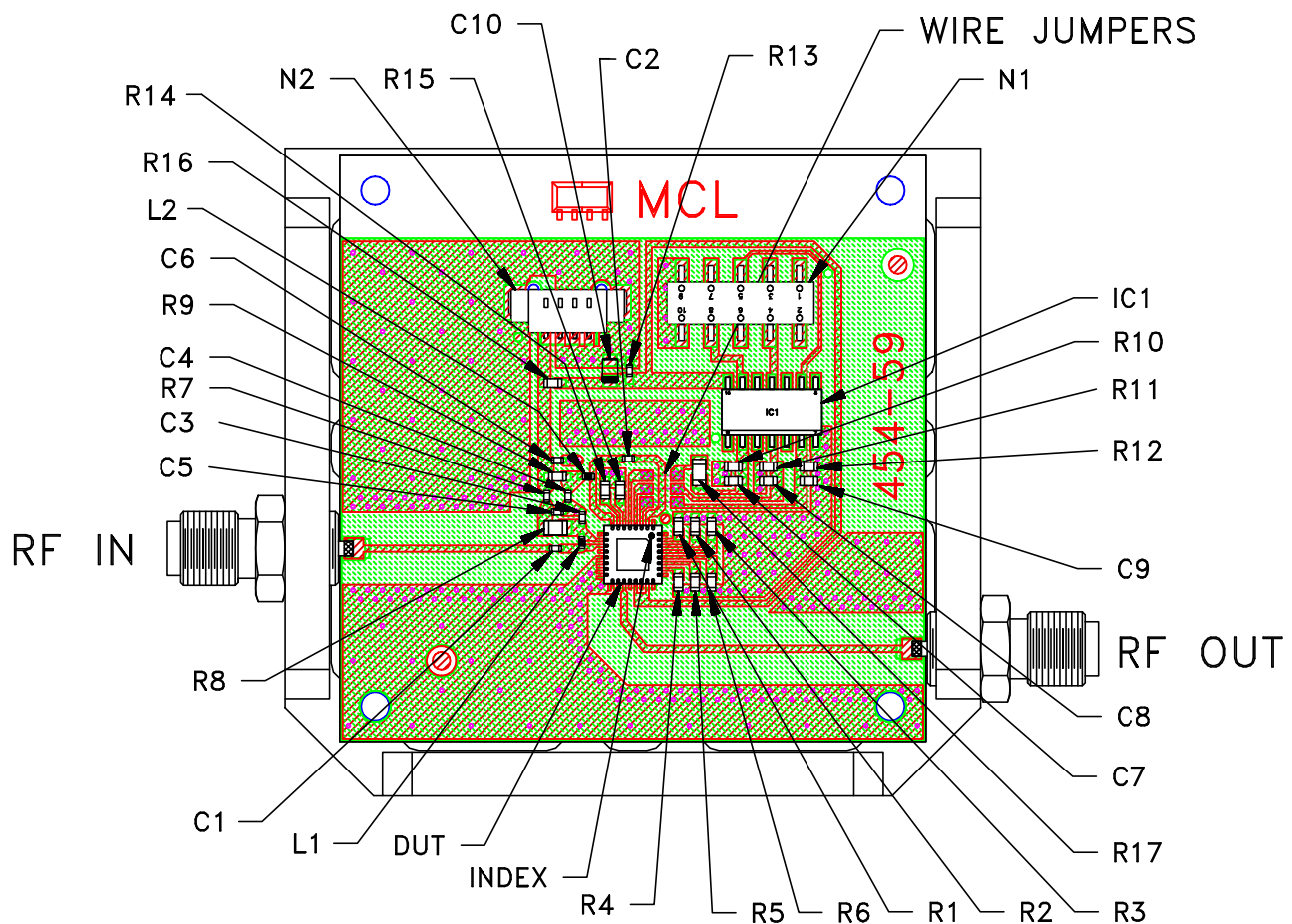

TB-DVGA3-122+

COMPONENT	DESCRIPTION/VALUE	SIZE
DUT	AMPLIFIER DVGA3-122+	5X5 MM
IC1	HEX INVERTING SCHMITT TRIGGER	-
N1	VERTICAL BREAKAWAY HEADER 10 CIRCUITS	-
N2	VERTICAL HEADER 4 CIRCUITS	-
C1,C2	CAPACITOR 0.001 $\mu$ F	0402
C3,C4	CAPACITOR 100 pF	0402
C5,C6	CAPACITOR 4.7 $\mu$ F	0603
C7,C8,C9	CAPACITOR 100 pF	0603
C10	CAPACITOR 0.47 $\mu$ F	0805
R1-R6	RESISTOR 10 K $\Omega$ m	0603
R7	RESISTOR 5.11 k $\Omega$ m	0402
R8	RESISTOR 49.9 $\Omega$ m	0805
R9	RESISTOR 0 $\Omega$ m	0603
R10,R11,R12,R14,R15	RESISTOR 10 K $\Omega$ m	0603
R17	RESISTOR 10 K $\Omega$ m	0805
R13	RESISTOR 681 $\Omega$ m	0603
R16	RESISTOR 475 $\Omega$ m	0603
L1	INDUCTOR 10 nH	0402
L2	INDUCTOR 8.2 nH	0402

## Notes:

1. Test cables for connectors "N1 & N2" are included in TB-\_\_\_\_+ package.
2. Test software "Digital Step Attenuator & DVGA" is available for download from Mini-Circuits website: [http://www.minicircuits.com/support/software\\_download.html](http://www.minicircuits.com/support/software_download.html)
3. 50 Ohm SMA Female connectors.
4. PCB Material: Rogers RO4350 or equivalent, Dielectric Constant=3.5, Thickness=.010 inch.

 Mini-Circuits®

# Evaluation Board and Circuit

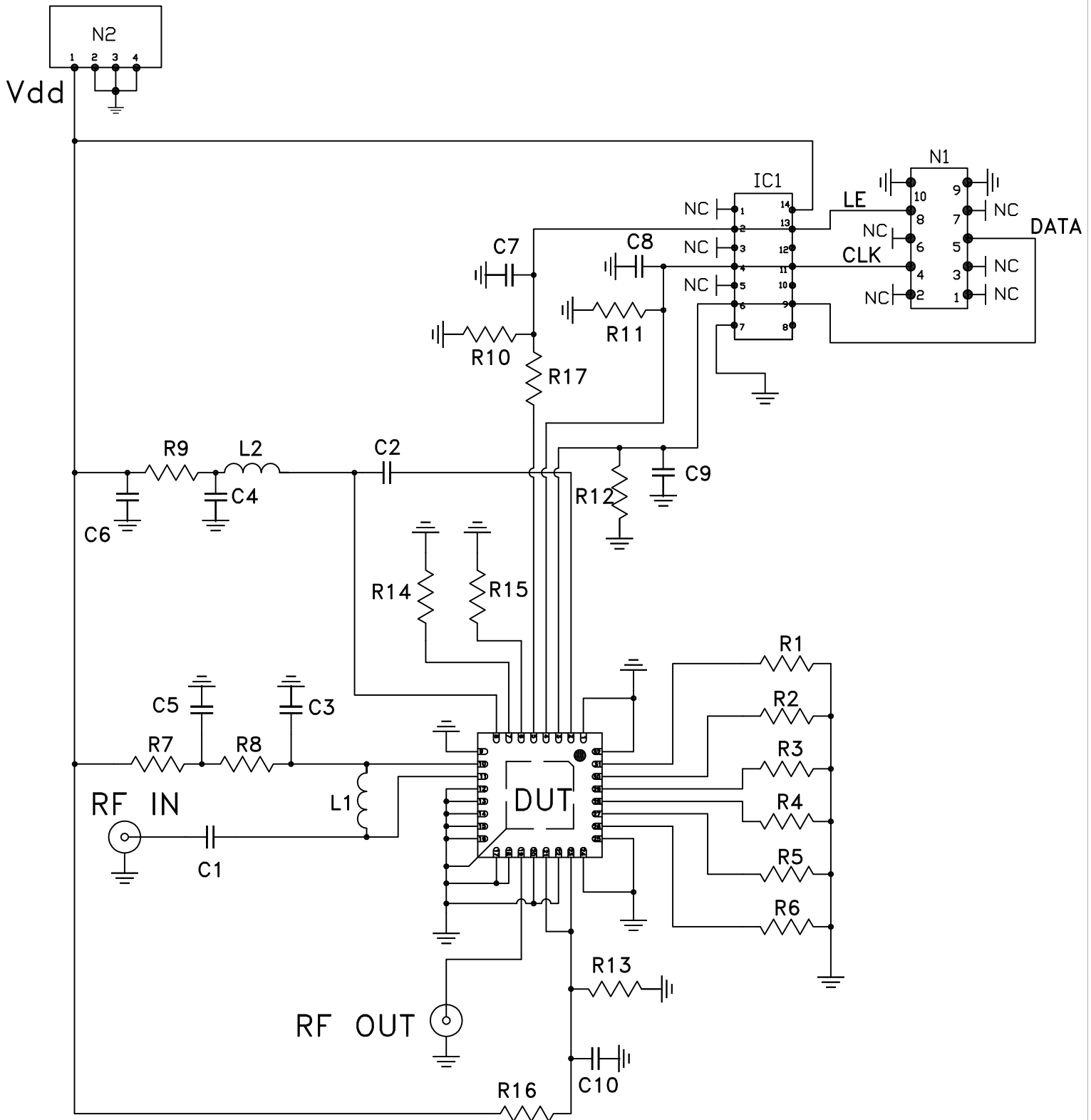

SCHEMATIC DIAGRAM

 Mini-Circuits®



All Mini-Circuits products are manufactured under exacting quality assurance and control standards, and are capable of meeting published specifications after being subjected to any or all of the following physical and environmental test.

Specification	Test/Inspection Condition	Reference/Spec
Operating Temperature	-40° to 85°C or -45° to 85°C Ambient Environment	Individual Model Data Sheet
Storage Temperature	-55° to 100° C or -65° to 150° Ambient Environment	Individual Model Data Sheet
Thermal Shock	-55° to 100°C, 100 cycles	MIL-STD-202, Method 107, Condition A-3, except +100°C
Mechanical Shock	1.5Kg, 0.5 ms, 5 shock pulses, Y1 direction only	MIL-STD-883, Method 2002, Condition B, except Y1 direction only
Vibration (Variable Frequency)	50g peak	MIL-STD-883, Method 2007, Condition B
Autoclave	15 psig, 100% RH, 121°C, 96 hours	JESD22-A102, Condition C
HAST	130°C, 85% RH, 96 hours	JESD22-A110
Solderability	10X Magnification	J-STD-002, Para 4.2.5, Test S, 95% Coverage
Solder Reflow Heat	Sn-Pb Eutetic Process: 240°C peak Pb-Free Process: 260°C peak	J-STD-020, Table 4-1, 4-2 and 5-2; Figure 5-1
Moisture Sensitivity: Level 1	Bake at 125°C for 24 hours Soak at 85°C/85% RH for 168 hours, Reflow 3 cycles at 260°C peak	J-STD-020
Marking Resistance to Solvents	Isopropyl alcohol + mineral spirits at 25°C; terpene defluxer at 25°C; distilled water + proylene glycol monomethyl ether +	MIL-STD-202, Method 215



All Mini-Circuits products are manufactured under exacting quality assurance and control standards, and are capable of meeting published specifications after being subjected to any or all of the following physical and environmental test.

<b>Specification</b>	<b>Test/Inspection Condition</b>	<b>Reference/Spec</b>
	monoethanolamine at 63°C to 70°C	