



MMIC SURFACE MOUNT

X2 Frequency Multiplier

CY2-283+

50Ω Output 7 to 28 GHz

THE BIG DEAL

- Wideband, Output 7 to 28 GHz
- Low Conversion Loss, 13 dB Typ.
- High Fundamental & Harmonic Suppression:
F1, 34 dBc Typ.; F3, 40 dBc Typ.; F4, 23 dBc Typ.
- Miniature Size 3 x 3 x 0.89 mm
- Aqueous Washable

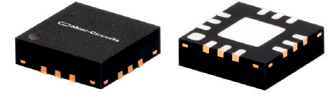

Generic photo used for illustration purposes only

CASE STYLE: DQ1225

+RoHS Compliant

The +Suffix identifies RoHS Compliance. See our website for methodologies and qualifications

APPLICATIONS

- Synthesizers
- Local Oscillators
- 5G

PRODUCT OVERVIEW

Mini-Circuits' CY2-283+ is an ultra-wideband MMIC frequency doubler, converting input frequencies from 3.5 to 14 GHz into output frequencies from 7 to 28 GHz. Its wide output range makes this model suitable for broadband systems as well as a wide variety of narrowband applications. Utilizing GaAs HBT technology, the multiplier comes housed in a tiny 3 x 3 x 0.89 mm MCLP package and offers excellent repeatability, low inductance, and good thermal efficiency.

KEY FEATURES

Features	Advantages
Broadband, 7 to 28 GHz Output	With an output frequency range spanning 7 to 28 GHz, this multiplier supports broadband applications such as defense and instrumentation as well as a wide range of narrowband system requirements including 5G.
Low Conversion Loss, 13 dB Typ.	With a low conversion loss, CY2-283+ produces higher output power, reducing the need for post amplification.
Excellent Fundamental and Harmonic Suppression: <ul style="list-style-type: none"> • F1, 34 dBc • F3, 40 dBc • F4, 23 dBc 	Reduces spurious signals and the need for additional filtering.
Wide Input Power Range, +12 to +18 dBm	Wide input power signal range accommodates different input signal levels while still maintaining a low conversion loss.
3 x 3 mm, 12 Lead MCLP Package	Low inductance, repeatable transitions, and excellent thermal contact to the PCB
Low Cost	Provides an easy, cost-effective solution for generating high-frequency signals from a lower frequency signal source.





MMIC SURFACE MOUNT

X2 Frequency Multiplier

CY2-283+

50Ω Output 7 to 28 GHz

ELECTRICAL SPECIFICATIONS¹ AT +25°C

Parameter	Input Frequency (GHz)	Min.	Typ.	Max.	Unit
Multiplier Factor		2			
Frequency Range, Input (F1)		3.5		14	GHz
Frequency Range, Output (F2)		7		28	GHz
Input Power		+12		+18	dBm
Conversion Loss	3.5-12		13	17.5	dB
	12-14		17	22.5	
Harmonic Output ²	F1	3.5-12	34		dBc
		12-14	17		
	F3	3.5-12	40		
		12-14	47		
	F4	3.5-12	23		

1. At +15 dBm input power measured on Mini-Circuits test board TB-973-CY2283C+.
 2. Harmonics of input frequency below the power of F2. Harmonics are measured to 50 GHz.

ABSOLUTE MAXIMUM RATINGS³

Parameter	Ratings
Operating Temperature	-40°C to +85°C
Storage Temperature	-65°C to +150°C
RF Input Power	+21 dBm

3. Permanent damage may occur if any of these limits are exceeded.

PAD CONNECTIONS

INPUT	5
OUTPUT	11
GROUND	4,6,10,12 & Paddle
NO CONNECTIONS	All Others

PRODUCT MARKING

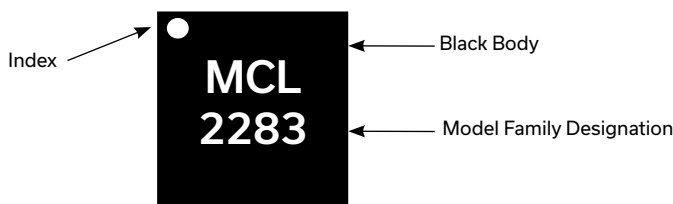

Marking may contain other features or characters for internal lot control.



MMIC SURFACE MOUNT

X2 Frequency Multiplier

CY2-283+

Mini-Circuits

50Ω Output 7 to 28 GHz

TYPICAL PERFORMANCE DATA

Input Frequency (GHz)	INPUT RF= +12 dBm				INPUT RF= +18 dBm					
	Conversion Loss (dB)	Harmonic Output Below F2 (-dBc)				Conversion Loss (dB)	Harmonic Output Below F2 (-dBc)			
		F2	F1	F3	F4		F2	F1	F3	F4
3.50	13.52	37.55	37.00	11.00	15.67	33.33	25.55	11.88		
4.20	10.66	36.61	42.37	15.60	12.99	31.90	29.61	23.79		
5.10	11.09	33.69	38.13	16.20	12.28	30.22	27.50	24.48		
6.00	13.89	26.80	47.69	17.37	14.10	26.66	30.24	14.96		
6.60	13.45	26.98	41.64	25.21	13.33	28.34	33.58	17.56		
7.00	12.82	24.30	43.41	31.27	12.80	27.40	32.78	20.49		
7.60	13.89	25.06	39.84	33.55	12.42	28.51	34.22	26.66		
8.20	15.48	24.06	42.34	36.21	12.85	32.40	43.95	23.22		
9.10	14.39	30.29	35.94	33.25	12.49	41.13	40.48	24.49		
10.00	14.26	37.81	43.07	47.00	13.26	33.90	44.53	26.20		
11.00	14.98	34.41	36.22	47.14	14.33	26.26	34.26	20.52		
12.00	15.62	21.26	43.46	42.31	15.78	23.43	43.37	23.29		
13.10	18.14	14.52	57.18	--	16.70	18.20	47.76	--		
13.70	20.72	11.14	51.26	--	19.64	15.53	44.17	--		
14.00	20.85	11.18	41.38	--	20.23	14.94	41.11	--		

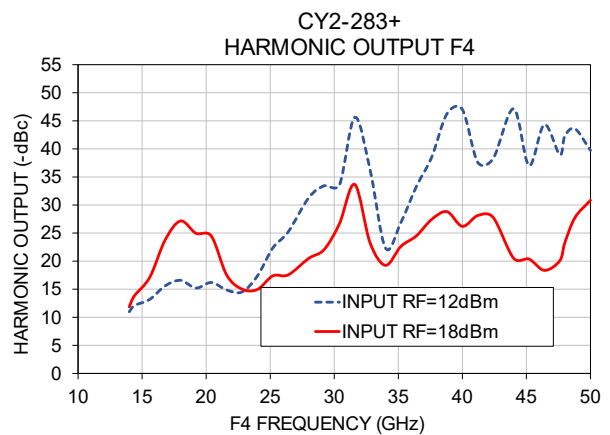
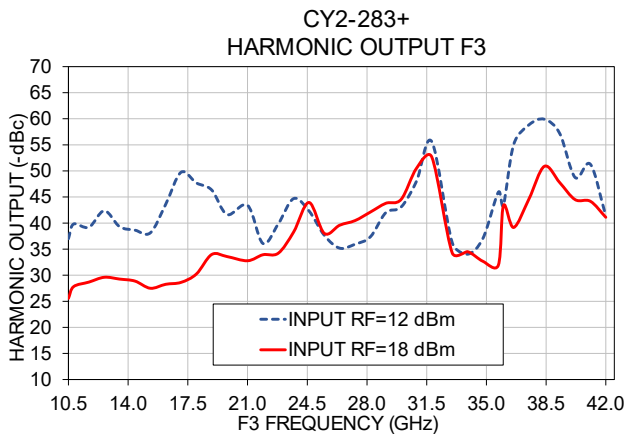
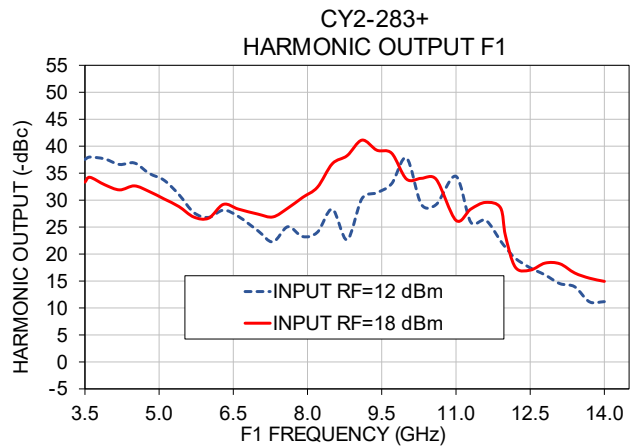
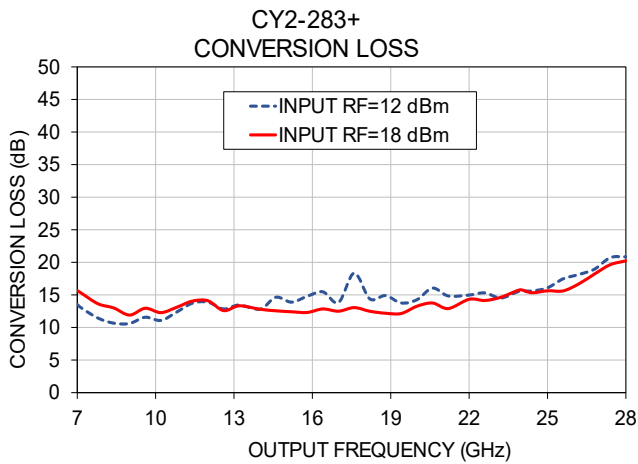



MMIC SURFACE MOUNT

X2 Frequency Multiplier

CY2-283+

Mini-Circuits

50Ω

Output 7 to 28 GHz

ADDITIONAL DETAILED TECHNICAL INFORMATION IS AVAILABLE ON OUR DASHBOARD. TO ACCESS [CLICK HERE](#)

Performance Data	Data Table Swept Graphs S-Parameter (S3P Files) Data Set (.zip file)
Case Style	DQ1225 Plastic package, exposed paddle lead finish: matte-tin
Tape & Reel Standard Quantities Available on Reel	F66 7" Reels with 20, 50, 100, 200, 500 or 1K devices
Suggested Layout for PCB Design	PL-476
Evaluation Board	TB-973-CY2283C+
Environmental Ratings	ENV08T1

ESD RATING

Human body model (HBM): Class 1C (1000 to <2000 V) in accordance with ANSI/ESD 5.1-2007

MSL TEST FLOW CHART

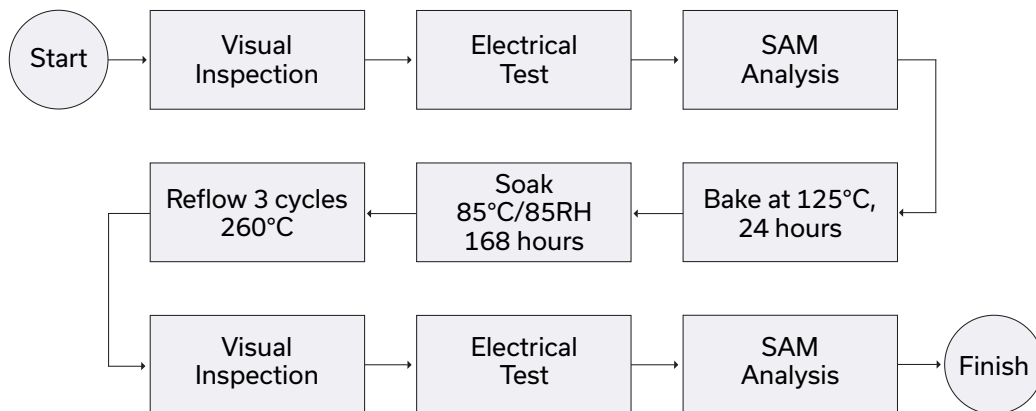

NOTES

- A. Performance and quality attributes and conditions not expressly stated in this specification document are intended to be excluded and do not form a part of this specification document.
- B. Electrical specifications and performance data contained in this specification document are based on Mini-Circuit's applicable established test performance criteria and measurement instructions.
- C. The parts covered by this specification document are subject to Mini-Circuits standard limited warranty and terms and conditions (collectively, "Standard Terms"); Purchasers of this part are entitled to the rights and benefits contained therein. For a full statement of the standard terms and the exclusive rights and remedies thereunder, please visit Mini-Circuits' website at www.minicircuits.com/terms/viewterm.html



Typical Performance Data

Frequency (GHz)				RF IN = 12dBm			
				Conversion Loss (dB)	Harmonic Output* (-dBc)		
X1 Output	X2 Output	X3 Output	X4 Output	X2 Output	X1 Output	X3 Output	X4 Output
3.0	6.0	9.0	12.0	17.59	36.02	31.45	12.21
3.3	6.6	9.9	13.2	12.96	39.07	35.91	11.79
3.5	7.0	10.5	14.0	13.52	37.55	37.00	11.00
3.6	7.2	10.8	14.4	12.88	37.99	39.81	12.08
3.9	7.8	11.7	15.6	11.43	37.63	39.20	13.20
4.2	8.4	12.6	16.8	10.66	36.61	42.37	15.60
4.5	9.0	13.5	18.0	10.62	36.89	39.31	16.59
4.8	9.6	14.4	19.2	11.57	34.95	38.64	15.21
5.1	10.2	15.3	20.4	11.09	33.69	38.13	16.20
5.4	10.8	16.2	21.6	12.35	31.03	43.60	14.86
5.7	11.4	17.1	22.8	13.72	27.70	49.74	14.52
6.0	12.0	18.0	24.0	13.89	26.80	47.69	17.37
6.3	12.6	18.9	25.2	12.84	28.14	46.34	22.35
6.6	13.2	19.8	26.4	13.45	26.98	41.64	25.21
7.0	14.0	21.0	28.0	12.82	24.30	43.41	31.27
7.3	14.6	21.9	29.2	14.64	22.26	36.09	33.43
7.6	15.2	22.8	30.4	13.89	25.06	39.84	33.55
7.9	15.8	23.7	31.6	14.79	23.24	44.69	45.62
8.2	16.4	24.6	32.8	15.48	24.06	42.34	36.21
8.5	17.0	25.5	34.0	13.84	28.32	37.65	22.34
8.8	17.6	26.4	35.2	18.35	22.66	35.19	26.89
9.1	18.2	27.3	36.4	14.39	30.29	35.94	33.25
9.4	18.8	28.2	37.6	14.90	31.37	37.37	38.51
9.7	19.4	29.1	38.8	13.77	33.05	41.99	46.26
10.0	20.0	30.0	40.0	14.26	37.81	43.07	47.00
10.3	20.6	30.9	41.2	16.04	29.22	48.01	37.60
10.6	21.2	31.8	42.4	14.85	29.18	55.61	38.26
11.0	22.0	33.0	44.0	14.98	34.41	36.22	47.14
11.3	22.6	33.9	45.2	15.31	25.90	34.0	37.03
11.6	23.2	34.8	46.4	14.53	26.30	37.08	44.34
11.9	23.8	35.7	47.6	15.40	22.46	45.92	38.96
12.0	24.0	36.0	48.0	15.62	21.26	43.46	42.31
12.2	24.4	36.6	48.8	15.61	19.22	55.07	43.57
12.5	25.0	37.5	50.0	16.09	17.45	58.85	39.72
12.8	25.6	38.4	--	17.47	16.14	59.91	--
13.1	26.2	39.3	--	18.14	14.52	57.18	--
13.4	26.8	40.2	--	18.95	13.94	48.75	--
13.7	27.4	41.1	--	20.72	11.14	51.26	--
14.0	28.0	42.0	--	20.85	11.18	41.38	--
14.3	28.6	42.9	--	24.34	7.36	36.72	--
14.6	29.2	43.8	--	25.97	4.77	34.05	--
15.0	30.0	45.0	--	31.13	-0.78	28.72	--

*Harmonic Output below power level of X2 Output .



Typical Performance Data

Frequency (GHz)				RF IN = 15dBm			
				Conversion Loss (dB)	Harmonic Output* (-dBc)		
X1 Output	X2 Output	X3 Output	X4 Output	X2 Output	X1 Output	X3 Output	X4 Output
3.0	6.0	9.0	12.0	16.60	40.56	30.77	11.79
3.3	6.6	9.9	13.2	14.10	38.51	30.66	11.97
3.5	7.0	10.5	14.0	14.35	36.57	31.39	10.99
3.6	7.2	10.8	14.4	13.74	37.13	33.88	12.60
3.9	7.8	11.7	15.6	12.35	35.99	34.15	15.02
4.2	8.4	12.6	16.8	11.80	34.73	36.08	19.68
4.5	9.0	13.5	18.0	10.83	35.47	34.40	20.21
4.8	9.6	14.4	19.2	11.93	33.91	33.63	17.03
5.1	10.2	15.3	20.4	11.41	32.50	32.37	17.72
5.4	10.8	16.2	21.6	12.59	30.60	34.04	15.12
5.7	11.4	17.1	22.8	13.41	28.10	36.41	13.59
6.0	12.0	18.0	24.0	13.42	27.77	38.34	14.48
6.3	12.6	18.9	25.2	12.05	29.81	43.15	17.68
6.6	13.2	19.8	26.4	12.75	28.83	40.99	18.10
7.0	14.0	21.0	28.0	12.44	26.82	40.29	21.74
7.3	14.6	21.9	29.2	13.03	25.76	42.36	23.09
7.6	15.2	22.8	30.4	12.76	28.14	41.99	27.96
7.9	15.8	23.7	31.6	13.00	27.87	40.39	36.00
8.2	16.4	24.6	32.8	13.54	29.20	43.16	24.59
8.5	17.0	25.5	34.0	12.71	33.28	36.90	18.44
8.8	17.6	26.4	35.2	14.30	32.24	37.63	25.69
9.1	18.2	27.3	36.4	12.69	37.86	37.90	25.86
9.4	18.8	28.2	37.6	12.57	41.21	39.70	29.35
9.7	19.4	29.1	38.8	12.16	43.76	44.22	30.39
10.0	20.0	30.0	40.0	13.17	39.63	45.99	28.15
10.3	20.6	30.9	41.2	14.02	46.76	52.26	32.60
10.6	21.2	31.8	42.4	12.99	49.93	56.51	32.36
11.0	22.0	33.0	44.0	13.95	35.44	38.61	23.50
11.3	22.6	33.9	45.2	13.90	45.34	36.87	25.10
11.6	23.2	34.8	46.4	14.07	39.29	36.65	21.99
11.9	23.8	35.7	47.6	14.97	24.14	38.25	23.90
12.0	24.0	36.0	48.0	15.26	21.55	50.01	27.31
12.2	24.4	36.6	48.8	14.94	18.43	50.57	31.48
12.5	25.0	37.5	50.0	15.33	17.57	60.47	32.99
12.8	25.6	38.4	--	15.91	18.17	49.53	--
13.1	26.2	39.3	--	17.00	17.37	48.12	--
13.4	26.8	40.2	--	18.20	15.75	45.57	--
13.7	27.4	41.1	--	19.56	13.89	48.33	--
14.0	28.0	42.0	--	20.04	13.40	40.30	--
14.3	28.6	42.9	--	22.85	10.77	36.07	--
14.6	29.2	43.8	--	24.37	8.47	38.68	--
15.0	30.0	45.0	--	28.95	3.75	39.12	--

*Harmonic Output below power level of X2 Output .

Frequency Multiplier (Doublers)

CY2-283+

Typical Performance Data

Frequency (GHz)				RF IN = 18dBm			
				Conversion Loss (dB)	Harmonic Output* (-dBc)		
X1 Output	X2 Output	X3 Output	X4 Output	X2 Output	X1 Output	X3 Output	X4 Output
3.0	6.0	9.0	12.0	17.23	40.10	25.41	12.05
3.3	6.6	9.9	13.2	15.43	35.29	25.22	13.04
3.5	7.0	10.5	14.0	15.67	33.33	25.55	11.88
3.6	7.2	10.8	14.4	15.16	34.23	27.81	13.83
3.9	7.8	11.7	15.6	13.63	32.85	28.68	17.14
4.2	8.4	12.6	16.8	12.99	31.90	29.61	23.79
4.5	9.0	13.5	18.0	11.91	32.64	29.26	27.16
4.8	9.6	14.4	19.2	12.95	31.60	28.88	24.97
5.1	10.2	15.3	20.4	12.28	30.22	27.50	24.48
5.4	10.8	16.2	21.6	13.09	28.81	28.26	17.53
5.7	11.4	17.1	22.8	14.05	26.87	28.63	15.02
6.0	12.0	18.0	24.0	14.10	26.66	30.24	14.96
6.3	12.6	18.9	25.2	12.60	29.22	33.98	17.38
6.6	13.2	19.8	26.4	13.33	28.34	33.58	17.56
7.0	14.0	21.0	28.0	12.80	27.40	32.78	20.49
7.3	14.6	21.9	29.2	12.56	26.89	33.93	22.05
7.6	15.2	22.8	30.4	12.42	28.51	34.22	26.66
7.9	15.8	23.7	31.6	12.31	30.50	38.28	33.66
8.2	16.4	24.6	32.8	12.85	32.40	43.95	23.22
8.5	17.0	25.5	34.0	12.50	36.75	38.02	19.26
8.8	17.6	26.4	35.2	13.05	38.25	39.59	22.63
9.1	18.2	27.3	36.4	12.49	41.13	40.48	24.49
9.4	18.8	28.2	37.6	12.19	39.26	42.11	27.43
9.7	19.4	29.1	38.8	12.15	38.70	43.79	28.81
10.0	20.0	30.0	40.0	13.26	33.90	44.53	26.20
10.3	20.6	30.9	41.2	13.76	34.04	50.49	28.13
10.6	21.2	31.8	42.4	12.91	33.87	52.66	27.80
11.0	22.0	33.0	44.0	14.33	26.26	34.26	20.52
11.3	22.6	33.9	45.2	14.15	28.34	34.52	20.38
11.6	23.2	34.8	46.4	14.62	29.58	32.67	18.36
11.9	23.8	35.7	47.6	15.59	28.59	31.91	20.07
12.0	24.0	36.0	48.0	15.78	23.43	43.37	23.29
12.2	24.4	36.6	48.8	15.33	17.57	39.16	27.80
12.5	25.0	37.5	50.0	15.63	17.02	44.65	30.84
12.8	25.6	38.4	--	15.62	18.32	50.89	--
13.1	26.2	39.3	--	16.70	18.20	47.76	--
13.4	26.8	40.2	--	18.21	16.49	44.50	--
13.7	27.4	41.1	--	19.64	15.53	44.17	--
14.0	28.0	42.0	--	20.23	14.94	41.11	--
14.3	28.6	42.9	--	22.49	12.09	37.01	--
14.6	29.2	43.8	--	23.86	10.50	36.69	--
15.0	30.0	45.0	--	28.10	6.28	33.22	--

*Harmonic Output below power level of X2 Output.



Typical Performance Curves

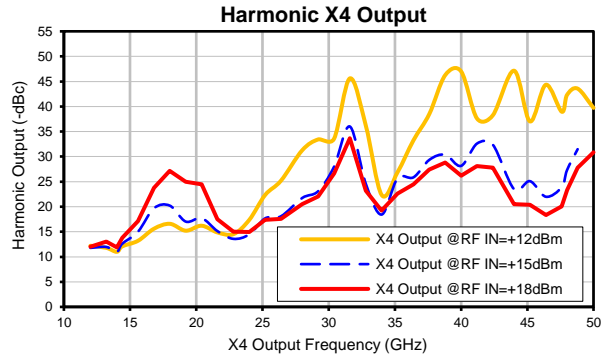
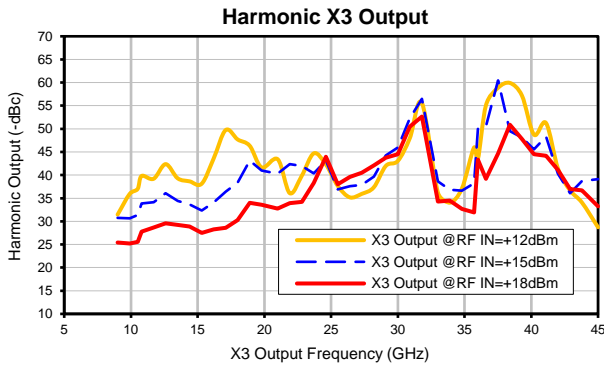
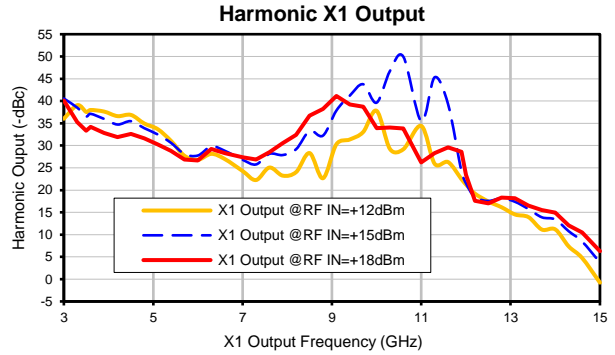
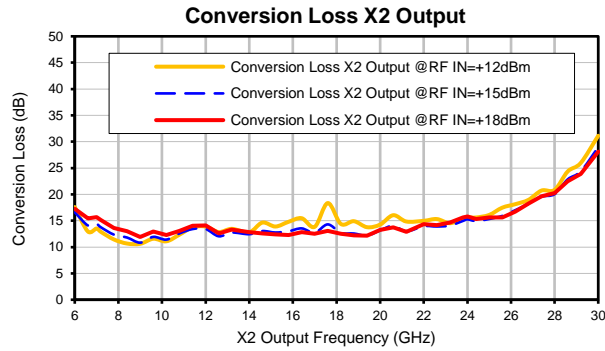

Outline Dimensions



PCB Land Pattern

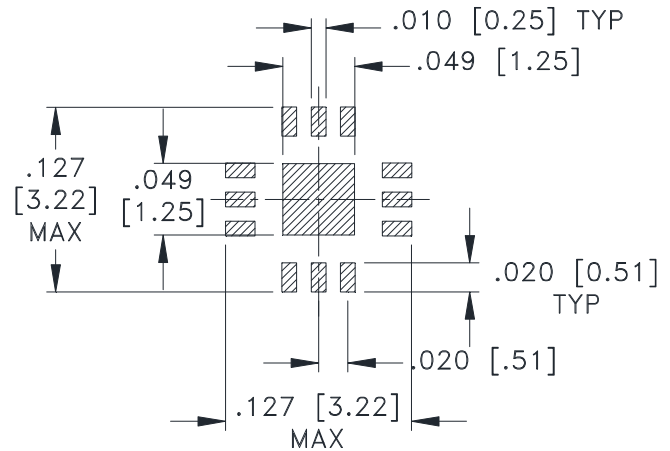

SUGGESTED LAYOUT,
TOLERANCE TO BE WITHIN $\pm .002$

Weight: .02 Grams

Dimensions are in inches (mm). Tolerances: 2Pl. $\pm .01$; 3 Pl. $\pm .004$

Notes:

1. Case material: Plastic.
2. Termination finish:
 - For RoHS Case Styles: Tin-Silver alloy plate over Nickel barrier or Matte-Tin. All models, (+) suffix. See Data sheet.
 - For RoHS-5 Case Styles: Tin-Lead plate. All models, no (+) suffix.

Mini-Circuits®

Distribution Centers NORTH AMERICA 800-654-7949 • 417-335-5935 • Fax 417-335-5945 • EUROPE 44-1252-832600 • Fax 44-1252-837010

Mini-Circuits ISO 9001 & ISO 14001 Certified

INTERNET <http://www.minicircuits.com>

P.O. Box 350166, Brooklyn, New York 11235-0003 (718) 934-4500 Fax (718) 332-4661

Tape & Reel Packaging TR-F66



Tape Width, mm	Device Cavity Pitch, mm	Reel Size, inches	Devices per Reel see note	
8	4	7	Small quantity standard	20
				50
				100
				200
				500
		7	Standard	1000, 2000, 3000

Note: Please consult individual model data sheet to determine device per reel availability.

Mini-Circuits carrier tape materials provide protection from ESD (Electro-Static Discharge) during handling and transportation. Tapes are static dissipative and comply with industry standards EIA-481/EIA-541.

Go to: www.minicircuits.com/pages/pdfs/tape.pdf

Mini-Circuits®

INTERNET <http://www.minicircuits.com>

P.O. Box 350166, Brooklyn, New York 11235-0003 (718) 934-4500 Fax (718) 332-4661

Distribution Centers NORTH AMERICA 800-654-7949 • 417-335-5935 • Fax 417-335-5945 • EUROPE 44-1252-832600 • Fax 44-1252-837010

Mini-Circuits ISO 9001 & ISO 14001 Certified

THIRD ANGLE PROJECTION

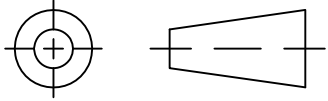

REVISIONS

REV OR	ECN No.	DESCRIPTION	DATE	DR	AUTH
	M165191	NEW RELEASE	12/13/17	ITG	JX

**SUGGESTED MOUNTING CONFIGURATION
FOR DQ1225 CASE STYLE, "12FM01" PIN CODE**

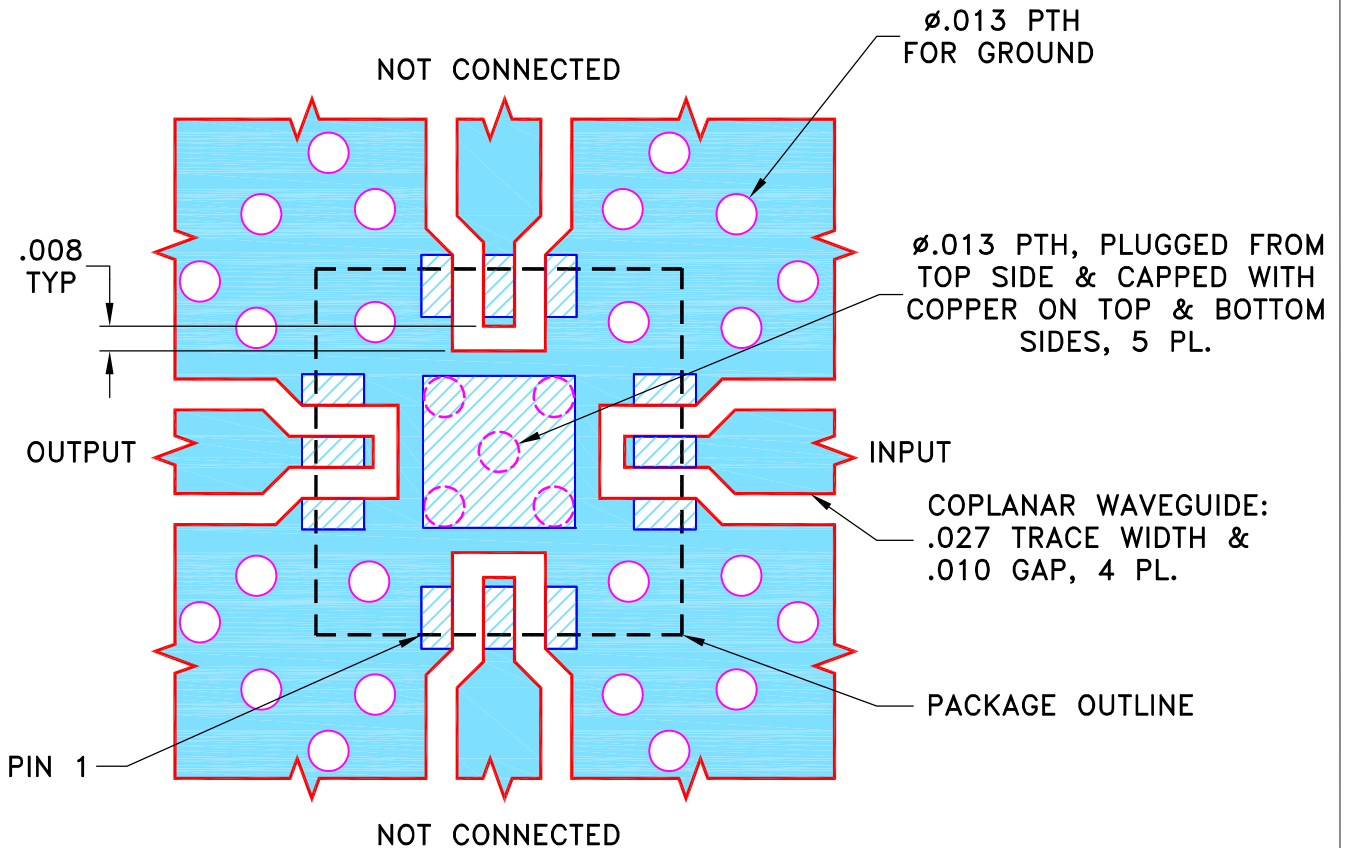

NOTES:

- TRACE WIDTH PARAMETERS ARE SHOWN FOR TACONIC TLY-5 WITH DIELECTRIC THICKNESS .010" ± .001". COPPER: 1/2 OZ. EACH SIDE. FOR OTHER MATERIALS TRACE WIDTH AND GAP MAY NEED TO BE MODIFIED.
- BOTTOM SIDE OF THE PCB IS CONTINUOUS GROUND PLANE.

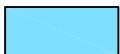

DENOTES PCB COPPER LAYOUT WITH SMOBC (SOLDER MASK OVER BARE COPPER).

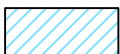

DENOTES COPPER LAND PATTERN FREE OF SOLDER MASK.

UNLESS OTHERWISE SPECIFIED	INITIALS	DATE
DIMENSIONS ARE IN INCHES	DRAWN ITG	12/11/17
TOLERANCES ON:	CHECKED GF	12/13/17
2 PL DECIMALS ±	APPROVED JX	12/13/17
3 PL DECIMALS ± .005		
ANGLES ±		
FRACTIONS ±		



Mini-Circuits®

13 Neptune Avenue
Brooklyn NY 11235

PL, 12FM01, DQ1225, TB-973+

SIZE	CODE IDENT	DRAWING NO:	REV:
A	15542	98-PL-541	OR
FILE:	98PL541	SCALE: 16:1	SHEET: 1 OF 1

Mini-Circuits®
THIS DOCUMENT AND ITS CONTENTS ARE THE PROPERTY OF MINI-CIRCUITS. EXCEPT FOR USE EXPRESSLY GRANTED, IN WRITING, TO ITS VENDORS, VENDEE AND THE UNITED STATES GOVERNMENT, MINI-CIRCUITS RESERVES ALL PROPRIETARY DESIGN, USE, MANUFACTURING AND REPRODUCTION RIGHTS THERETO. THESE CONTENTS SHALL NOT BE USED, DUPLICATED OR DISCLOSED TO ANY OUTSIDE PARTY, IN WHOLE OR IN PART, WITHOUT WRITTEN PERMISSION OF MINI-CIRCUITS.

Evaluation Board and Circuit

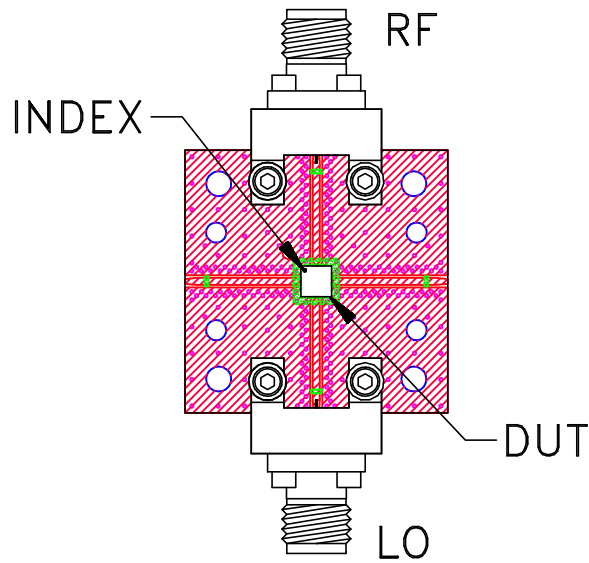

TB-973-CY2283C+

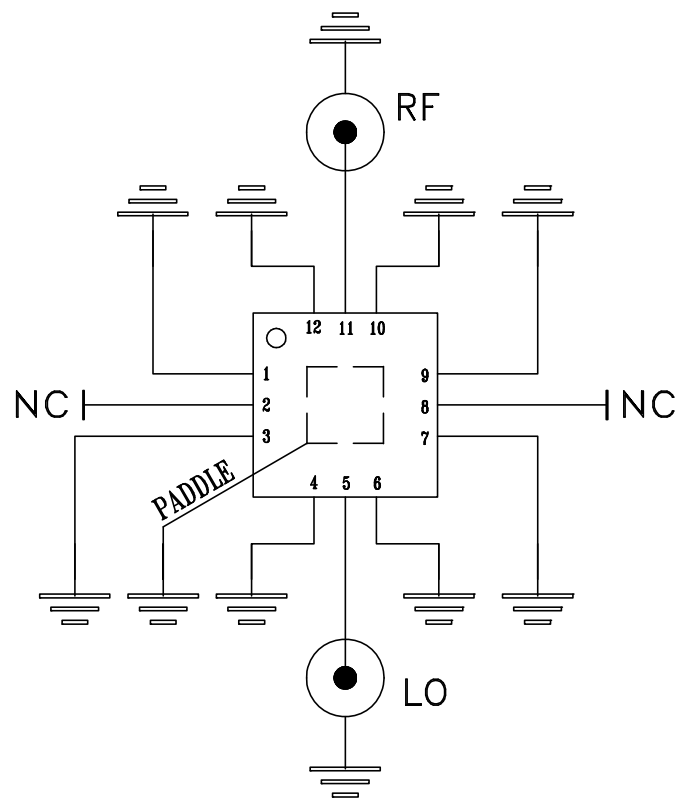

Schematic Diagram

Notes:

1. 50 Ohm 2.92mm Female end launch connectors.
2. PCB Material: TLY-5 or equivalent,
Dielectric Constant=2.2, Thickness=.010 inch.

 **Mini-Circuits®**

All Mini-Circuits products are manufactured under exacting quality assurance and control standards, and are capable of meeting published specifications after being subjected to any or all of the following physical and environmental test.

Specification	Test/Inspection Condition	Reference/Spec
Operating Temperature	-40° to 85° C or -45° to 85° C or -55° to 105° C or -40° to 105° C or -40° to 95° C Ambient Environment	Individual Model Data Sheet
Storage Temperature	-55° to 100° C or -65° to 150° Ambient Environment	Individual Model Data Sheet
HTOL	1000 hours at 125°C	MIL-STD-883, Method 1005, Condition B
Thermal Shock	-55° to 100°C, 100 cycles	MIL-STD-202, Method 107, Condition A-3, except +100°C
Mechanical Shock	1.5Kg, 0.5 ms, 5 shock pulses, Y1 direction only	MIL-STD-883, Method 2002, Condition B, except Y1 direction only
Vibration (Variable Frequency)	50g peak	MIL-STD-883, Method 2007, Condition B
Autoclave	15 psig, 100% RH, 121°C, 96 hours	JESD22-A102, Condition C
HAST	130°C, 85% RH, 96 hours	JESD22-A110
Solderability	10X Magnification	J-STD-002, Para 4.2.5, Test S, 95% Coverage
Solder Reflow Heat	Sn-Pb Eutetic Process: 240°C peak Pb-Free Process: 260°C peak	J-STD-020, Table 4-1, 4-2 and 5-2; Figure 5-1
Moisture Sensitivity: Level 1	Bake at 125°C for 24 hours Soak at 85°C/85% RH for 168 hours, Reflow 3 cycles at 260°C peak	J-STD-020



All Mini-Circuits products are manufactured under exacting quality assurance and control standards, and are capable of meeting published specifications after being subjected to any or all of the following physical and environmental test.

Specification	Test/Inspection Condition	Reference/Spec
Marking Resistance to Solvents	Isopropyl alcohol + mineral spirits at 25°C; terpene defluxer at 25°C; distilled water + proylene glycol monomethyl ether + monoethanolamine at 63°C to 70°C	MIL-STD-202, Method 215