

# LTCC Coupler

## CPJC-28-252R+

50Ω 2400 to 2500 MHz 28dB Coupling



Generic photo used for illustration purposes only  
CASE STYLE: JC0603C

### Maximum Ratings

Operating Temperature	-55°C to 100°C
Storage Temperature*	-55°C to 100°C

\*Refer to product storage temperature after installation.  
Suggestion for T&R unused product storage condition: +5--+35°C, Humidity 45-75%RH, 12 Month max.  
Permanent damage may occur if any of these limits are exceeded.

### Pad Connections

Input	1
GND	2
Coupled Out	3
Termination	4
GND	5
Main Out	6

### Outline Drawing

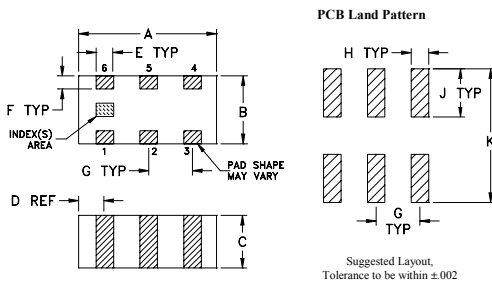

### Outline Dimensions (inch/mm)

A	B	C	D	E	F
.063	.031	.024	.012	.008	.006
1.60	0.79	0.61	0.30	0.20	0.15

G	H	J	K	wt
.020	.010	.022	.053	grams
0.51	0.25	0.56	1.35	0.005

### Features

- miniature size 0603 (0.063"[1.6mm]) x 0.031"[0.8mm] x 0.024"[0.6mm])
- low cost
- aqueous washable

### Applications

- ISM Band
- WLAN
- Bluetooth
- Zigbee

**+RoHS Compliant**  
The +Suffix identifies RoHS Compliance. See our web site for RoHS Compliance methodologies and qualifications

**Available Tape and Reel at no extra cost**

Reel Size	Devices/Reel
7"	20, 50, 100, 200, 500, 1000, 4000

### Electrical Specifications at 25°C

Parameter	Frequency (MHz)	Min.	Typ.	Max.	Unit
Frequency Range		2400		2500	MHz
Mainline Loss	2400 - 2500	—	0.3	0.4	dB
Coupling	2400 - 2500	—	28±2.0	—	dB
Directivity	2400 - 2500	6.5	10	—	dB
Return Loss (Input)	2400 - 2500	—	32	—	dB
Return Loss (Output)	2400 - 2500	—	39	—	dB
Input Power	2400 - 2500	—	—	2	W

1. Derate linearly to 1W at 100°C

### Typical Performance Data

Frequency (GHz)	Mainline Loss (dB) In-Out	Coupling (dB) In-Cpl	Directivity (dB)	Return Loss (dB)		
				In	Out	Cpl
2.40	0.26	26.41	11.35	30.38	47.41	2.04
2.41	0.26	26.42	11.28	30.27	45.13	2.02
2.42	0.26	26.43	11.18	30.18	43.31	2.01
2.43	0.26	26.42	11.10	29.98	41.62	2.00
2.44	0.26	26.43	11.02	29.88	40.12	1.99
2.45	0.26	26.43	10.95	29.74	38.82	1.98
2.46	0.27	26.43	10.86	29.53	37.61	1.97
2.47	0.27	26.44	10.77	29.37	36.60	1.96
2.48	0.27	26.44	10.70	29.16	35.59	1.95
2.49	0.27	26.44	10.61	28.94	34.70	1.94
2.50	0.27	26.45	10.53	28.69	33.92	1.93

### Evaluation Board MCL P/N: TB-CPJC28-252R+ Suggested PCB Layout (PL-440)

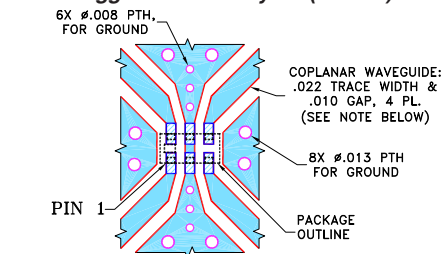

- NOTES:**
1. COPLANAR WAVEGUIDE IS SHOWN FOR ROGERS RO4350B WITH DIELECTRIC THICKNESS .010" ± .001". COPPER: 1/2 OZ. EACH SIDE. FOR OTHER MATERIALS TRACE WIDTH AND GAP MAY NEED TO BE MODIFIED.
  2. BOTTOM SIDE OF THE PCB IS CONTINUOUS GROUND PLANE.

- DENOTES PCB COPPER LAYOUT WITH SMOBC (SOLDER MASK OVER BARE COPPER).
- DENOTES COPPER LAND PATTERN FREE OF SOLDER MASK.

### Notes

- Performance and quality attributes and conditions not expressly stated in this specification document are intended to be excluded and do not form a part of this specification document.
- Electrical specifications and performance data contained in this specification document are based on Mini-Circuit's applicable established test performance criteria and measurement instructions.
- The parts covered by this specification document are subject to Mini-Circuit's standard limited warranty and terms and conditions (collectively, "Standard Terms"); Purchasers of this part are entitled to the rights and benefits contained therein. For a full statement of the Standard Terms and the exclusive rights and remedies thereunder, please visit Mini-Circuit's website at [www.minicircuits.com/WCLStore/terms.jsp](http://www.minicircuits.com/WCLStore/terms.jsp)

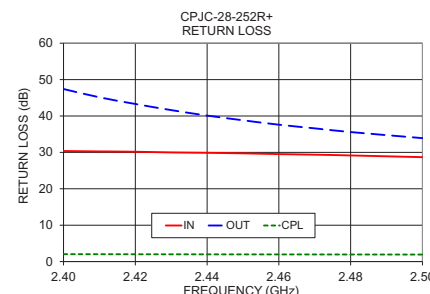
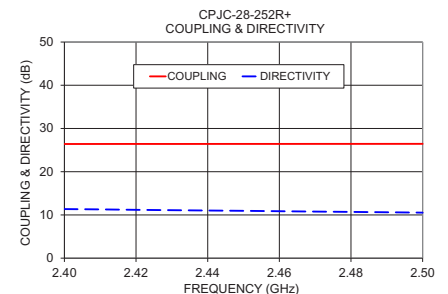
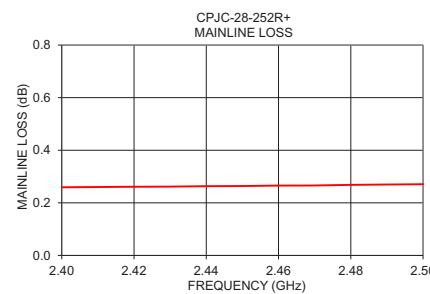

### Electrical Schematic

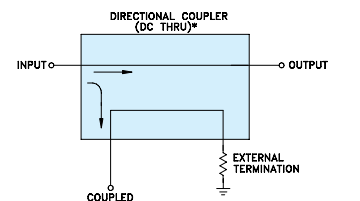

\* ELECTRICAL SCHEMATIC FOR DIRECTIONAL COUPLERS REQUIRING EXTERNAL TERMINATION THAT IS DESIGNED WITHOUT INTERNAL TRANSFORMERS.



## Typical Performance Data

FREQ. (MHz)	INSERTION LOSS (dB)	COUPLING (dB)	DIRECTIVITY (dB)	RETURN LOSS		
				IN	OUT	CPL
2400	0.26	26.41	11.35	30.38	47.41	2.04
2410	0.26	26.42	11.28	30.27	45.13	2.02
2420	0.26	26.43	11.18	30.18	43.31	2.01
2430	0.26	26.42	11.10	29.98	41.62	2.00
2440	0.26	26.43	11.02	29.88	40.12	1.99
2450	0.26	26.43	10.95	29.74	38.82	1.98
2460	0.27	26.43	10.86	29.53	37.61	1.97
2470	0.27	26.44	10.77	29.37	36.60	1.96
2480	0.27	26.44	10.70	29.16	35.59	1.95
2490	0.27	26.44	10.61	28.94	34.70	1.94
2500	0.27	26.45	10.53	28.69	33.92	1.93

## Typical Performance Curves

### Insertion Loss

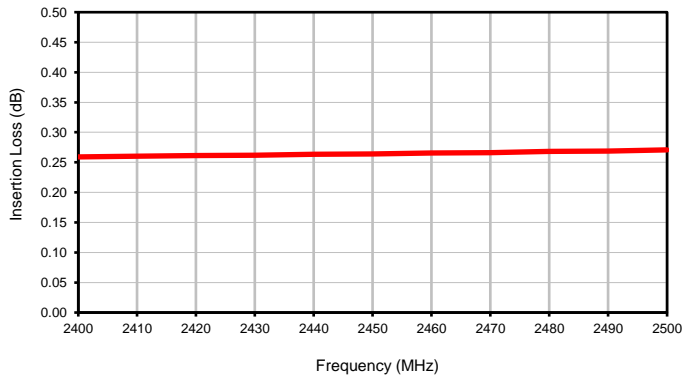

### Coupling

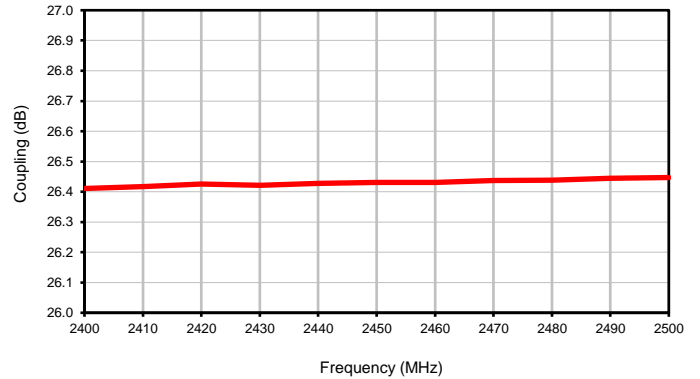

### Directivity

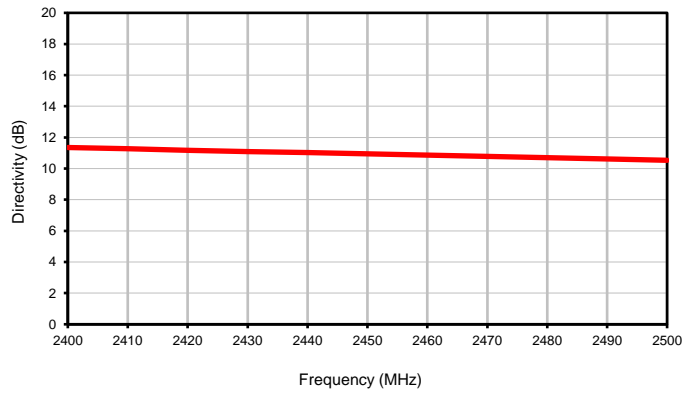

### Return Loss

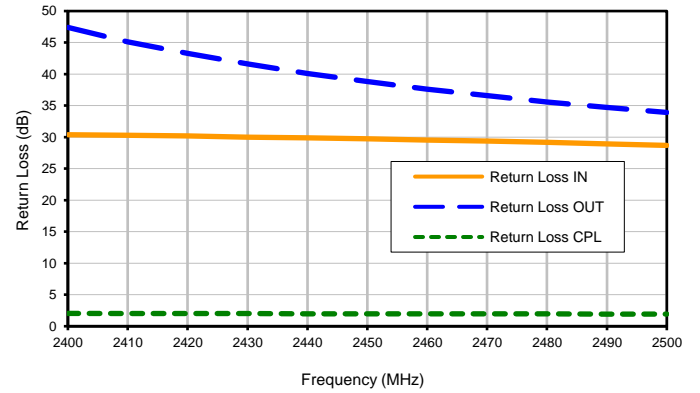

## Outline Dimensions

JC0603C

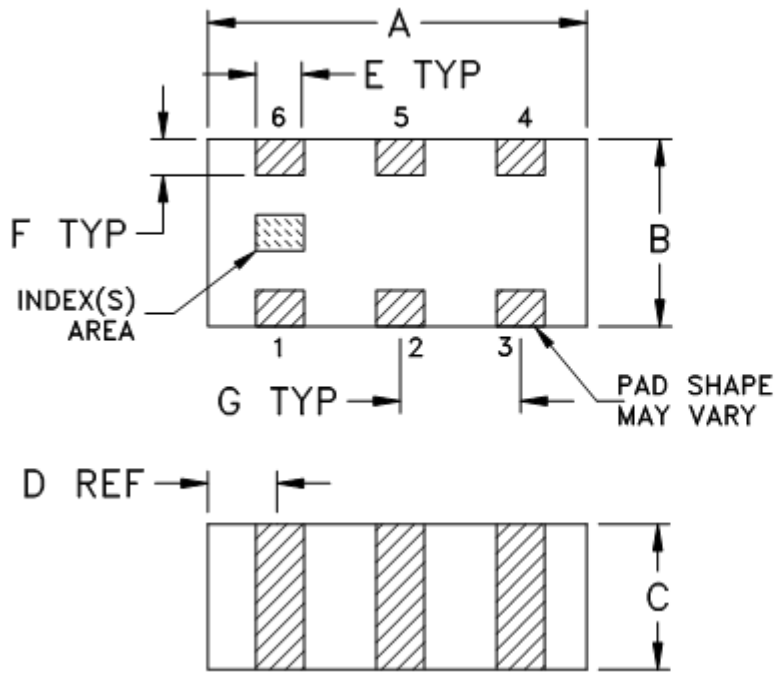

## PCB Land Pattern

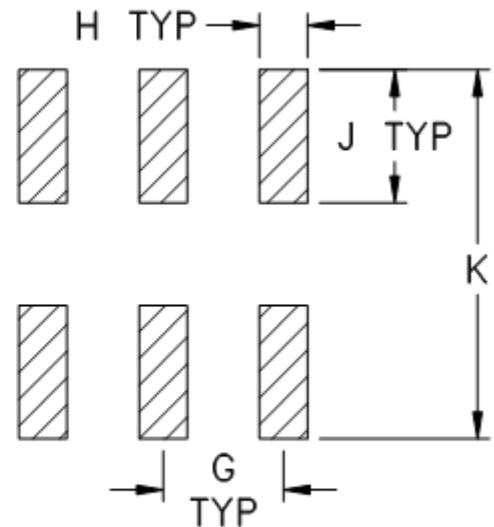

Suggested Layout,  
Tolerance to be within  $\pm .002$

CASE #	A	B	C	D	E	F	G	H	J	K	WT. GRAM
JC0603C	.063 (1.60)	.031 (0.80)	.024 (0.60)	.012 (0.30)	.008 (0.20)	.006 (0.15)	.020 (0.50)	.010 (0.25)	.022 (0.55)	0.053 (1.35)	.005

Dimensions are in inches (mm). Tolerances: 2 Pl.  $\pm .01$ ; 3 Pl.  $\pm .005$

### Notes:

- Open style, ceramic base.
- Termination finish:  
For RoHS Case Styles: Tin plate over Nickel plate. All models, (+) suffix.



P.O. Box 350166, Brooklyn, New York 11235-0003 (718) 934-4500 Fax (718) 332-4661 For detailed performance specs & shopping online see Mini-Circuits web site



The Design Engineers Search Engine Provides ACTUAL Data Instantly From MINI-CIRCUITS At: [www.minicircuits.com](http://www.minicircuits.com)

RF/IF MICROWAVE COMPONENTS

# Tape & Reel Packaging TR-F114

## DEVICE ORIENTATION IN T&R

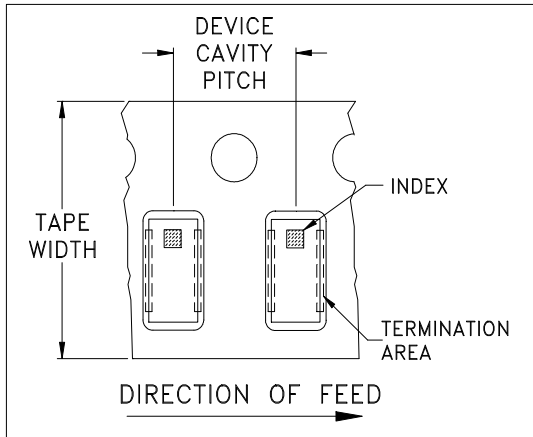

ILLUSTRATION 1

Applicable Case Styles	
GE0805C	JC0603C
GE0805C-1	JC0603C-4
GE0805C-1AP	JC0603C-6
GE0805C-7	
GE0805C-9	
GE0805C-10	
GE0805C-11	
GE0805C-12	

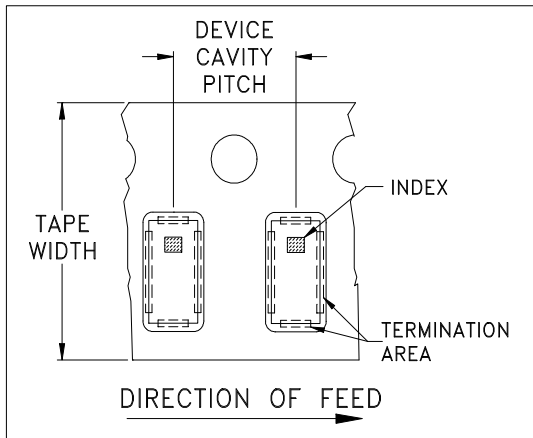

ILLUSTRATION 2

Applicable Case Styles	
GE0805C-2	JC0603C-1
GE0805C-3	JC0603C-2
GE0805C-4	JC0603C-3
GE0805C-5	JC0603C-5
GE0805C-6	JC0603C-7
GE0805C-8	JV1210C-1
GE0805C-15	

Tape Width, mm	Device Cavity Pitch, mm	Reel Size, inches	Devices per Reel	
8	4	7	Small quantity standards (see note)	20
				50
				100
				200
				500
				1000
			Standard	4000

Note: Please Consult individual model data sheet to determine device per reel availability.

Mini-Circuits carrier tape materials provide protection from ESD (Electro-Static Discharge) during handling and transportation. Tapes are static dissipative and comply with industry standards EIA-481/EIA-541.

Go to: [www.minicircuits.com/pages/pdfs/tape.pdf](http://www.minicircuits.com/pages/pdfs/tape.pdf)



INTERNET <http://www.minicircuits.com>

P.O. Box 350166, Brooklyn, New York 11235-0003 (718) 934-4500 Fax (718) 332-4661

Distribution Centers NORTH AMERICA 800-654-7949 • 417-335-5935 • Fax 417-335-5945 • EUROPE 44-1252-832600 • Fax 44-1252-837010

Mini-Circuits ISO 9001 & ISO 14001 Certified

THIRD ANGLE PROJECTION

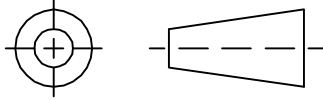

REVISIONS

REV	ECN No.	DESCRIPTION	DATE	DR	AUTH
OR	M148537	NEW RELEASE	10/14/14	GF	MY

**SUGGESTED MOUNTING CONFIGURATION  
FOR JC0603C CASE STYLE, "06DC12" PIN CODE**

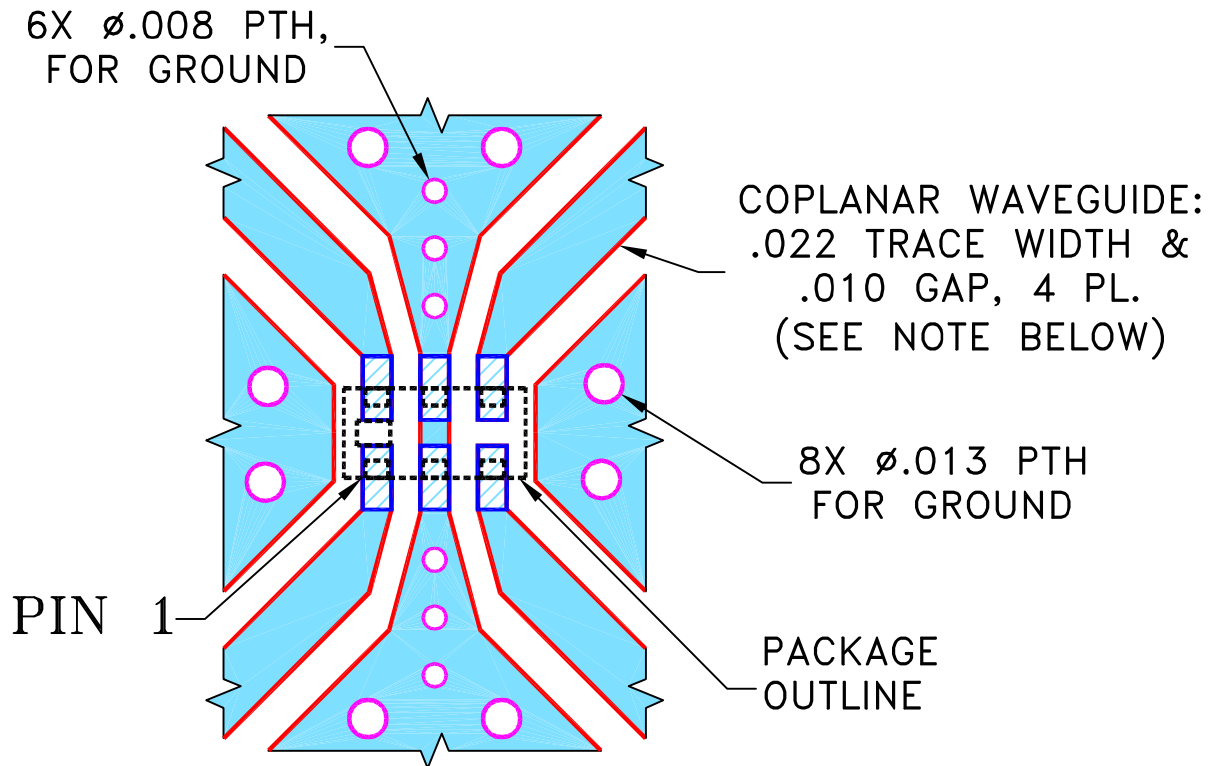

**NOTES:**

1. COPLANAR WAVEGUIDE IS SHOWN FOR ROGERS RO4350B WITH DIELECTRIC THICKNESS .010" ± .001". COPPER: 1/2 OZ. EACH SIDE. FOR OTHER MATERIALS TRACE WIDTH AND GAP MAY NEED TO BE MODIFIED.
2. BOTTOM SIDE OF THE PCB IS CONTINUOUS GROUND PLANE.

-  DENOTES PCB COPPER LAYOUT WITH SMOBC (SOLDER MASK OVER BARE COPPER).
-  DENOTES COPPER LAND PATTERN FREE OF SOLDER MASK.

UNLESS OTHERWISE SPECIFIED	INITIALS	DATE
DRAWN	GF	10/07/14
CHECKED	AV	10/14/14
APPROVED	MY	10/14/14

 **Mini-Circuits®** 13 Neptune Avenue  
Brooklyn NY 11235

**PL, 06DC12, JC0603C, TB-794+**

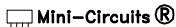
 Mini-Circuits®  
THIS DOCUMENT AND ITS CONTENTS ARE THE PROPERTY OF MINI-CIRCUITS. EXCEPT FOR USE EXPRESSLY GRANTED, IN WRITING, TO ITS VENDORS, VENDEE AND THE UNITED STATES GOVERNMENT, MINI-CIRCUITS RESERVES ALL PROPRIETARY DESIGN, USE, MANUFACTURING AND REPRODUCTION RIGHTS THERETO. THESE CONTENTS SHALL NOT BE USED, DUPLICATED OR DISCLOSED TO ANY OUTSIDE PARTY, IN WHOLE OR IN PART, WITHOUT WRITTEN PERMISSION OF MINI-CIRCUITS.  
ASHEETA1.DWG REV:A DATE:01/12/95

SIZE	CODE IDENT	DRAWING NO:	REV:
A	15542	98-PL-440	OR
FILE:	98PL440	SCALE: 15:1	SHEET: 1 OF 1

# Evaluation Board and Circuit

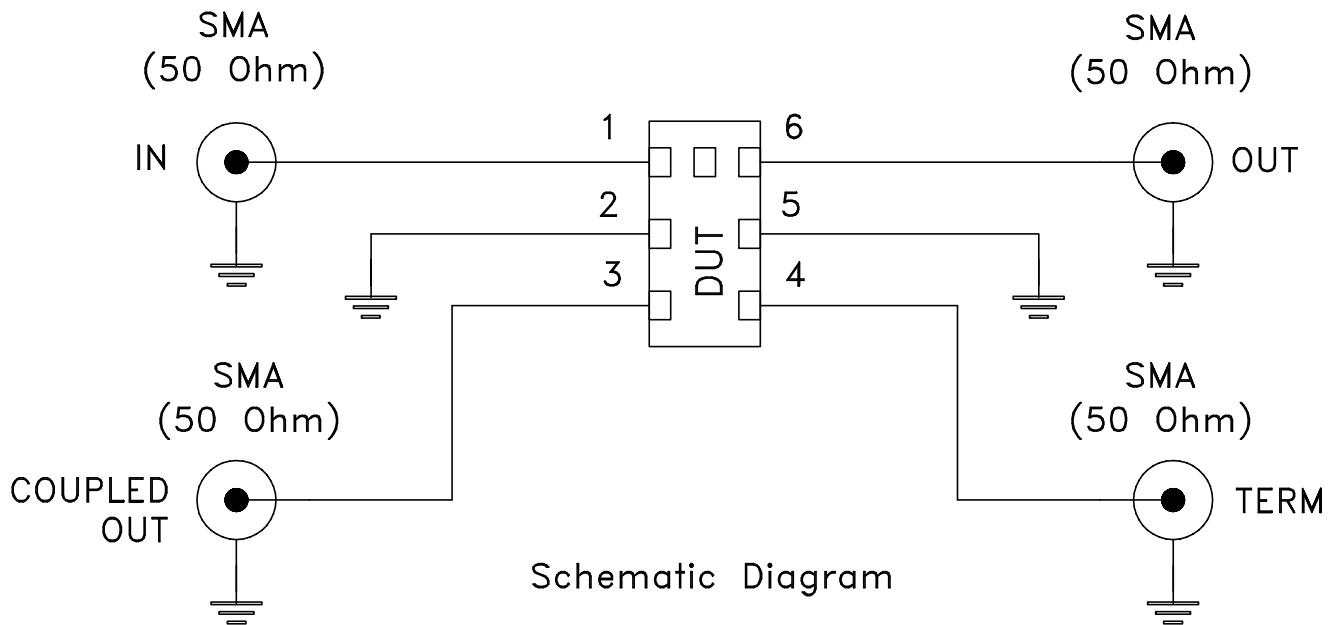
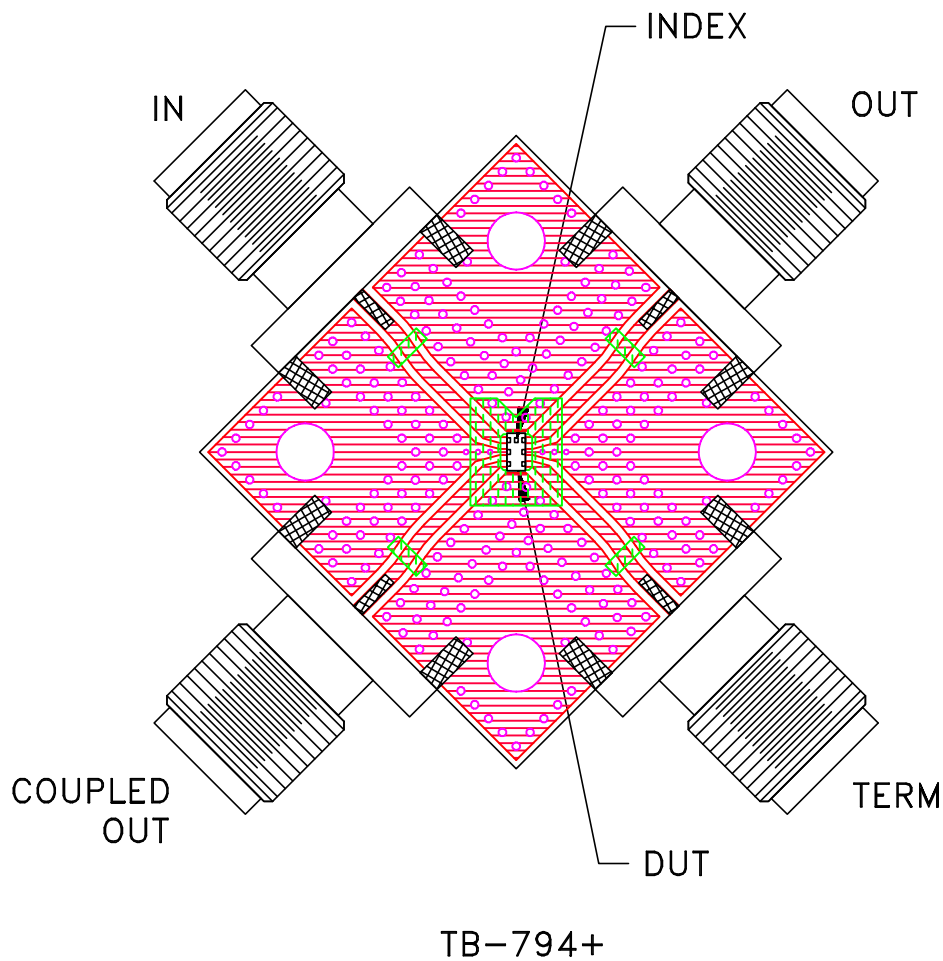

**Notes:**

1. 50 Ohm SMA Female connectors.
2. PCB Material: R04350 or equivalent,  
Dielectric Constant=3.5, Thickness=.010 inch.

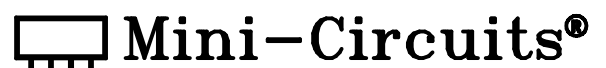

All Mini-Circuits products are manufactured under exacting quality assurance and control standards, and are capable of meeting published specifications after being subjected to any or all of the following physical and environmental test.

Specification	Test/Inspection Condition	Reference/Spec
Operating Temperature	-55° to 100°C Ambient Environment	Individual Model Data Sheet
Storage Temperature	-55° to 100° C Ambient Environment	Individual Model Data Sheet
Humidity	90 to 95% RH, 240 hours, 50°C	MIL-STD-202, Method 103, Condition A, Except 50°C and end-point electrical test done within 12 hours
Solder Reflow Heat	Sn-Pb Eutetic Process: 225°C peak Pb-Free Process 245° - 250°C peak	J-STD-020, Table 4-1, 4-2 and 5-2, Figure 5-1
Solderability	10X Magnification	J-STD-002, Para 4.2.5, Test S, 95% Coverage
Vibration (High Frequency)	20g peak, 10-2000 Hz, 12 times in each of three perpendicular directions (total 36)	MIL-STD-202, Method 204, Condition D
Mechanical Shock	50g, 11 ms, 1/2-sine, 18 shocks: 3 each direction, each of 3 axes	MIL-STD-202, Method 213, Condition A