



COAXIAL NON-ISOLATING

Power Splitter/Combiner

COM-G90G9316K+

50Ω 8-Way-0° / 180° 900 to 930 MHz 7/16 DIN Female to WR975 16kW

THE BIG DEAL

- Very high-power handling, up to 16kW CW
- Exceptionally low insertion loss, 0.1dB typ.
- Low amplitude unbalance (0.1dB typ.) and phase unbalance (1° typ.)



Generic photo used for illustration purposes only

APPLICATIONS

- RF energy generators
- Industrial heating
- Plasma generators
- Magnetron power splitter

FUNCTIONAL DIAGRAM

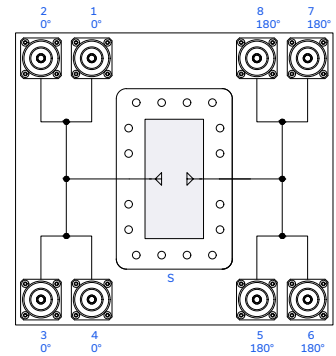

PRODUCT OVERVIEW

Mini-Circuits' COM-G90G9316K+ is an 8-way 0° / 180° non-isolating combiner providing very high power handling and exceptionally low insertion loss across 900 to 930 MHz. It is designed to maximize the efficiency of high-power amplifiers and generators working in the ISM 915MHz band.

KEY FEATURES

Features	Advantages
Non-Isolating Differential Combiner	The COM-G90G9316K+ is a non-isolating combiner (i.e. no internal isolating resistors). All performance parameters, when used as a combiner, are based upon 1-4 ports fed in phase and 5-8 ports fed in anti-phase. Differential architecture helps to improve EMI and minimize size of the combiner.
Power handling up to 16kW in a very compact size	This makes COM-G90G9316K+ suitable for cost effective, high-power solid state power amplifier application
Low insertion loss, 0.1 dB	Low insertion loss results in low power dissipation and easy thermal management, high power combining efficiency
Optimized distribution of electrical, thermal and mechanical stress	Excellent ruggedness and long-term reliability
Low amplitude unbalance (0.1dB typ.) and phase unbalance (1° typ.)	High power combining efficiency. Precise signal distribution when used as the splitter

REV. OR
NPO-004686
COM-G90G9316K+
MCL NY
241001





COAXIAL NON-ISOLATING

Power Splitter/Combiner

COM-G90G9316K+

Mini-Circuits

50Ω 8-Way-0° / 180° 900 to 930 MHz 7/16 DIN Female to WR975 16kW

ELECTRICAL SPECIFICATIONS AT T_{CASE} = +25°C

Parameter	Frequency (MHz)	Min.	Typ.	Max.	Units
Frequency Range	-	900	-	930	MHz
Insertion Loss (above 9 dB) ¹	900-930	-	0.1	0.3	dB
Phase Unbalance (±) ^{1,2}	900-930	-	1	5	Degree
Amplitude Unbalance (±) ^{1,2}	900-930	-	0.1	0.3	dB
VSWR (Port S)	900-930	-	1.1	1.22	:1
Power Handling ¹	As Splitter ^{2,4}	900-930	-	20,000	W
	As Combiner ^{3,4}	900-930	-	20,000	

- Ports 1-4 fed with in-phase input signals and ports 5-8 fed with anti-phase input signals when used as combiner, for derating vs temperature and VSWR, see graph below
- All ports must be terminated with 50 Ω.
- As a combiner of coherent signals, max. power per port is 2000W.

POWER DERATING CURVE

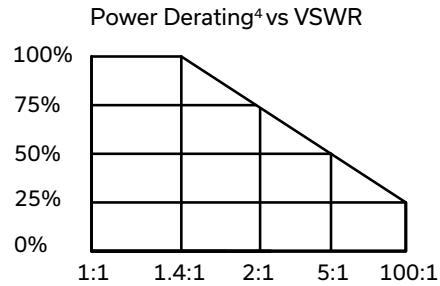
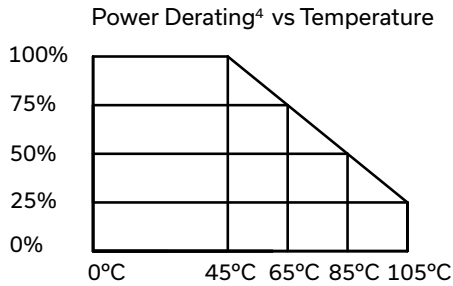

4. Power derating chart is based on units operated in CW mode

ABSOLUTE MAXIMUM RATINGS⁵

Parameter	Ratings
Operating Case Temperature ⁶	0 °C to +105 °C
Storage Temperature	0 °C to +105 °C

- Permanent damage may occur if any of these limits are exceeded.
- Units can be operated up to 105°C. Please refer to power derating chart.





TYPICAL PERFORMANCE DATA ACROSS FREQUENCY ($T_{CASE} = +25^{\circ}C$, 50Ω SYSTEM)

INSERTION LOSS vs FREQUENCY

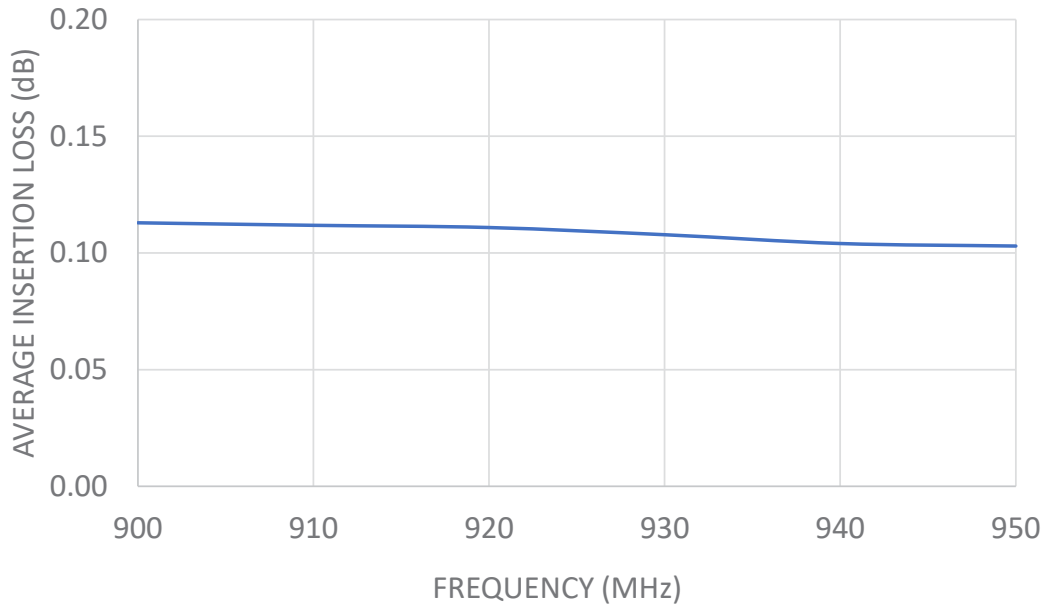

AMPLITUDE UNBALANCE vs FREQUENCY

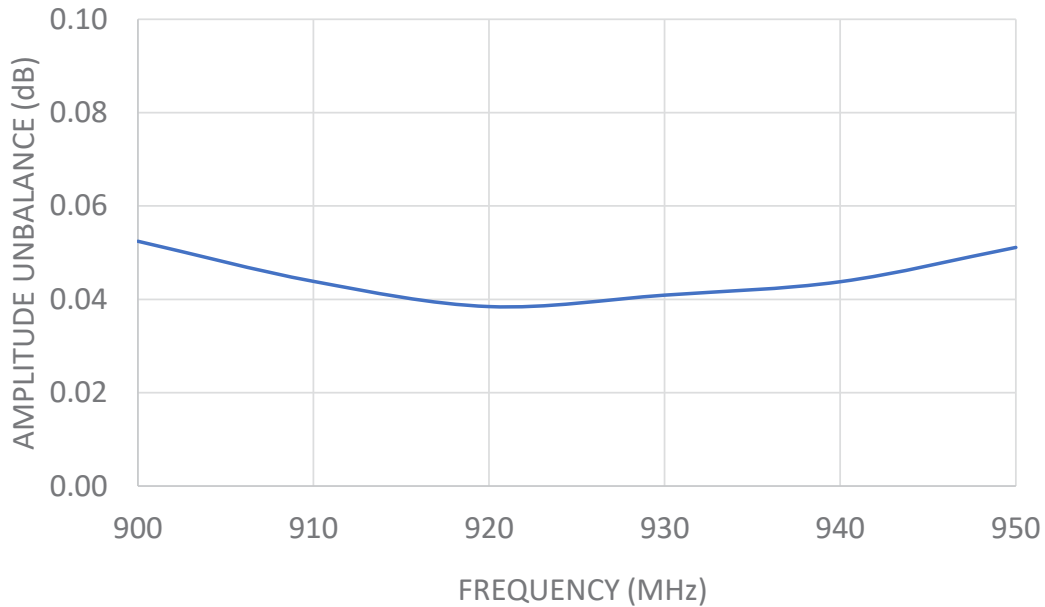



COAXIAL NON-ISOLATING

Power Splitter/Combiner

COM-G90G9316K+

Mini-Circuits

50Ω 8-Way-0° / 180° 900 to 930 MHz 7/16 DIN Female to WR975 16kW

TYPICAL PERFORMANCE DATA ACROSS FREQUENCY ($T_{CASE} = +25^{\circ}C$, 50Ω SYSTEM)

PHASE UNBALANCE vs FREQUENCY

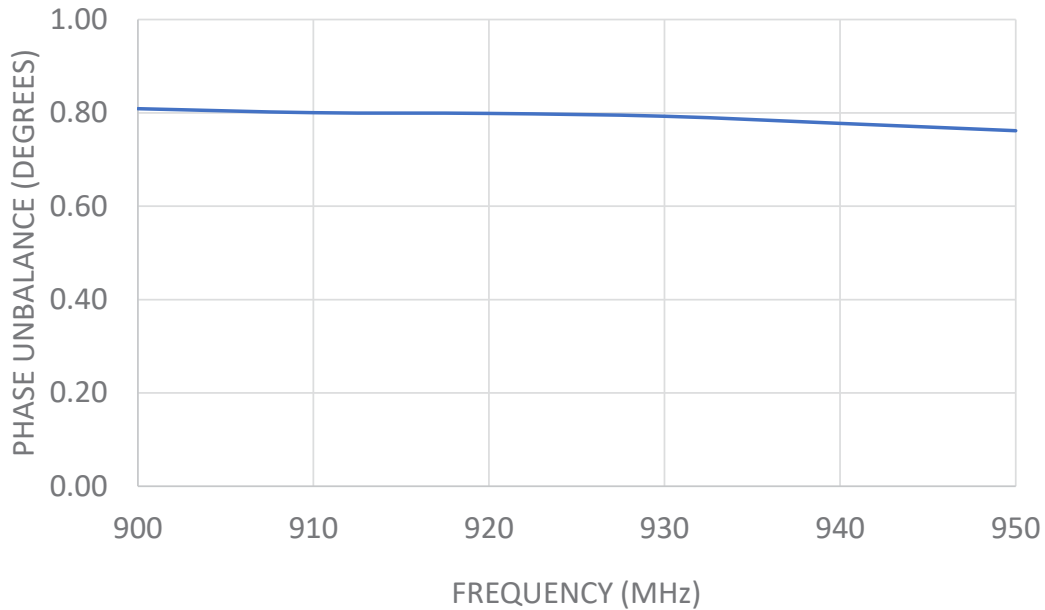

VSWR vs FREQUENCY

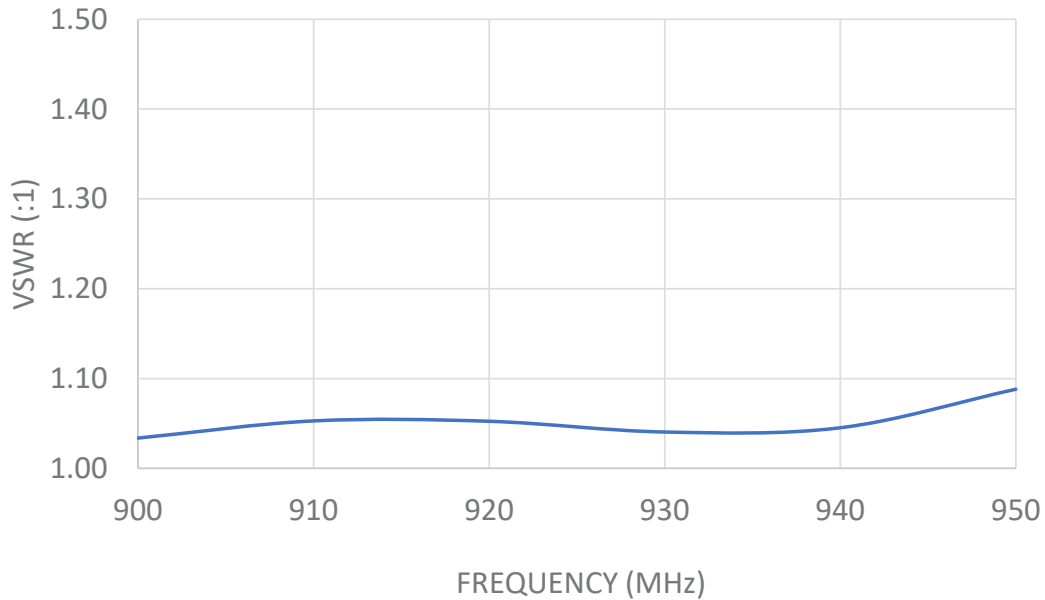



COAXIAL NON-ISOLATING

Power Splitter/Combiner

COM-G90G9316K+

Mini-Circuits

50Ω 8-Way-0° / 180° 900 to 930 MHz 7/16 DIN Female to WR975 16kW

COAXIAL CONNECTIONS

(Ports 1-8)	7/16 DIN Female
(Port S)	WR975 waveguide, CRPF flange

CASE STYLE DRAWING

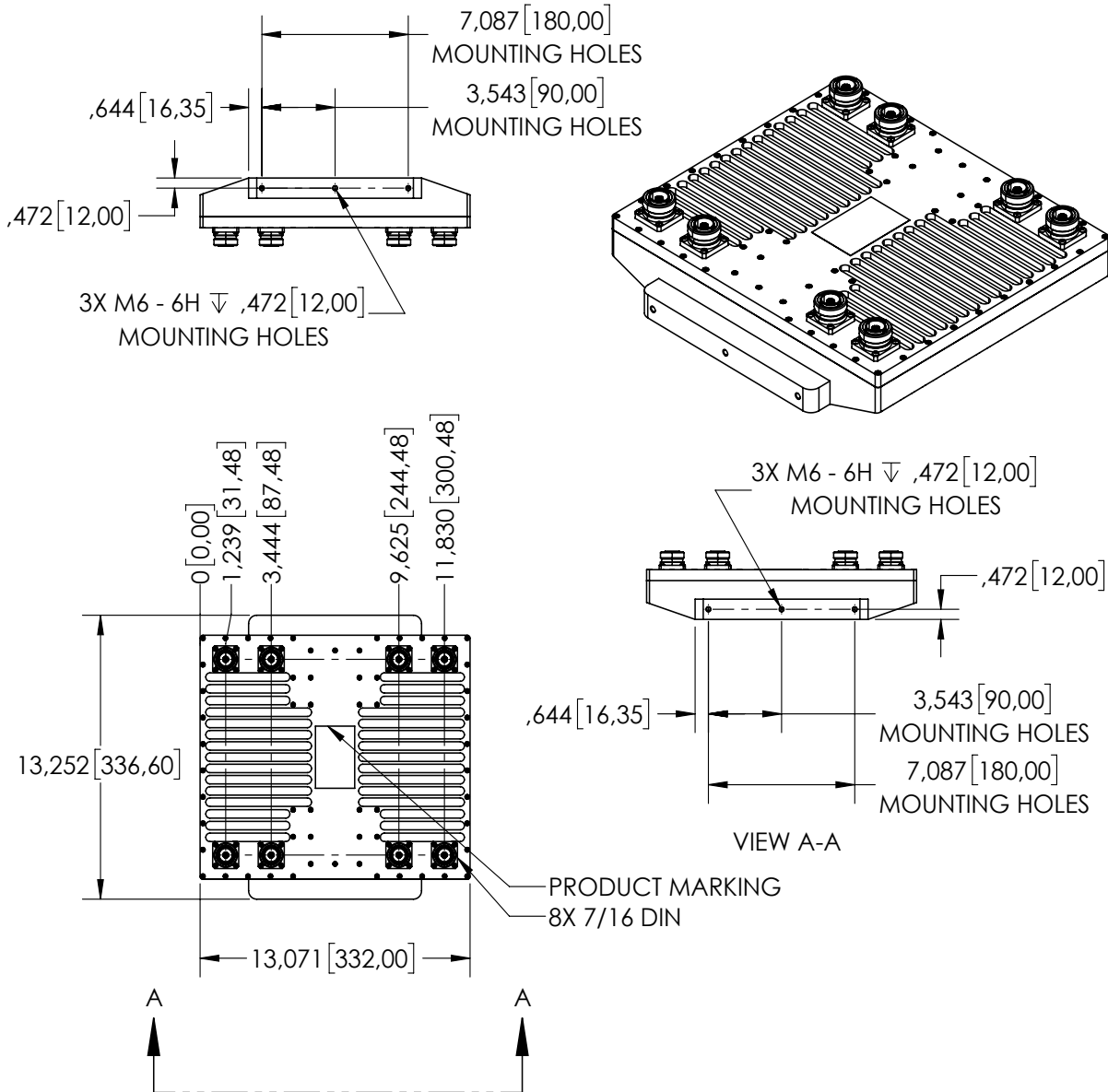

Weight: 9784 grams

Dimensions are in inches [mm]. Tolerances: 2 Pl. 0.03 inch; 3 Pl. 0.015 inch

PRODUCT MARKING*: COM-G90G9316K+

*Marking may contain other features or characters for internal lot control.





COAXIAL NON-ISOLATING

Power Splitter/Combiner

COM-G90G9316K+

Mini-Circuits

50Ω 8-Way-0° / 180° 900 to 930 MHz 7/16 DIN Female to WR975 16kW

ADDITIONAL INFORMATION IS AVAILABLE ON OUR DASHBOARD

[CLICK HERE](#)

Performance	Data Graphs
Case Style	VU3601
RoHS Status	Compliant
Environmental Ratings	ENV28T21

- NOTES
- A. Performance and quality attributes and conditions not expressly stated in this specification document are intended to be excluded and do not form a part of this specification document.
 - B. Electrical specifications and performance data contained in this specification document are based on Mini-Circuit's applicable established test performance criteria and measurement instructions.
 - C. The parts covered by this specification document are subject to Mini-Circuits standard limited warranty and terms and conditions (collectively, "Standard Terms"); Purchasers of this part are entitled to the rights and benefits contained therein. For a full statement of the standard terms and the exclusive rights and remedies thereunder, please visit Mini-Circuits' website at www.minicircuits.com/terms/viewterm.html



Typical Performance Data

Data tested at 25 DegC

FREQ. (MHz)	AVERAGE INSERTION LOSS ¹ (dB)	AMP. UNBAL. ² (dB)	PHASE UNBAL. ³ (deg.)	VSWR ⁴ (:1) S
900.00	0.11	0.05	0.81	1.03
910.00	0.11	0.04	0.80	1.05
920.00	0.11	0.04	0.80	1.05
930.00	0.11	0.04	0.79	1.04
940.00	0.10	0.04	0.78	1.05
950.00	0.10	0.05	0.76	1.09

Note:

1. Insertion loss is above theoretical loss (9.03 dB)
2. Amplitude unbalance is average unbalance between any ports
3. Phase unbalance is average unbalance between ports
4. VSWR is typical representation of S ports

Typical Performance Curves

Data tested at 25 DegC

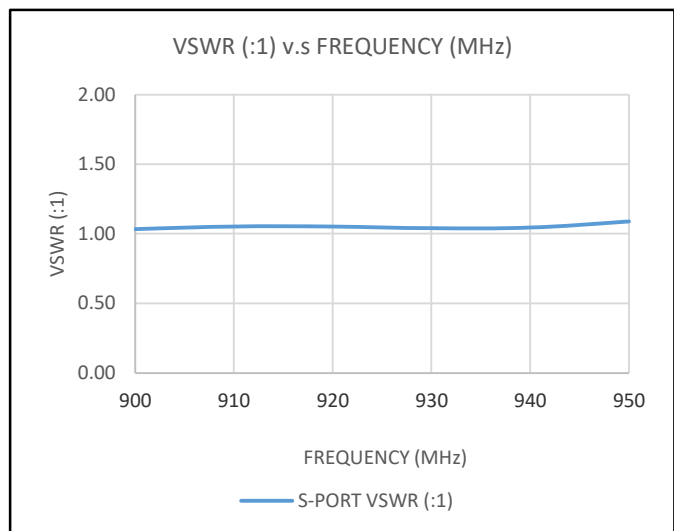
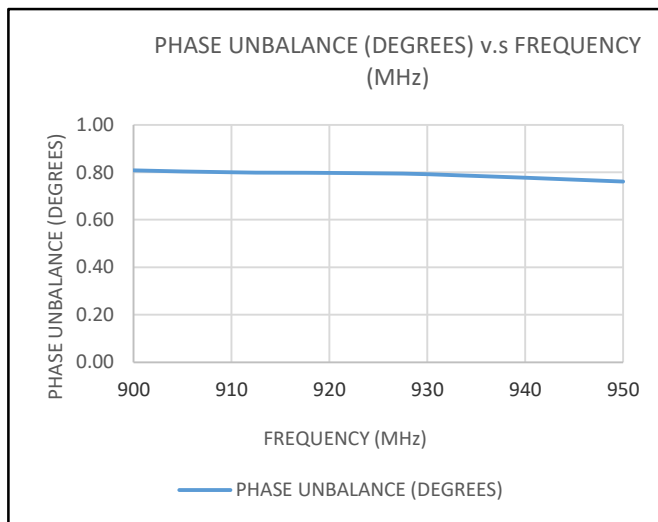
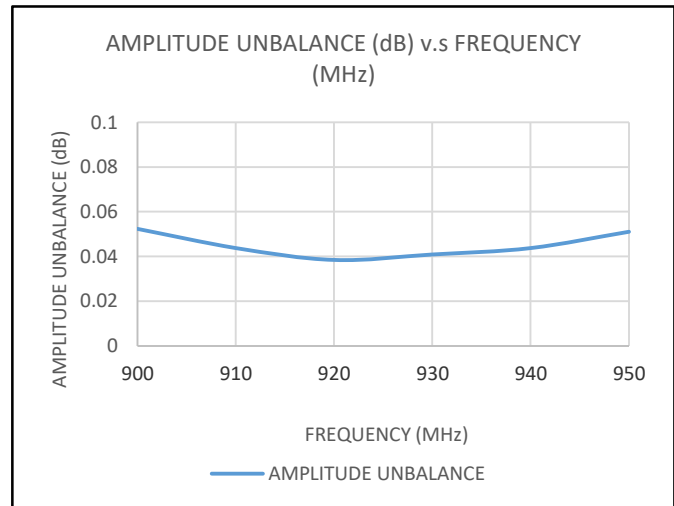
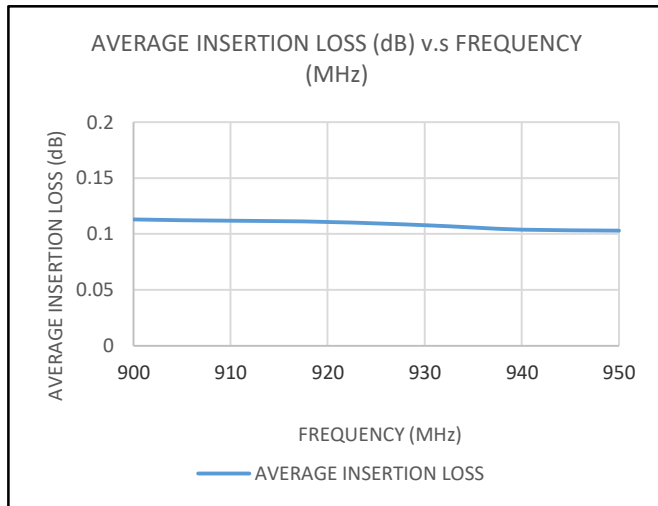

Note:

1. Insertion loss is loss above theoretical loss (9.03 dB)
2. Amplitude unbalance is average unbalance between any ports
3. Phase unbalance is average unbalance between ports
4. VSWR is typical representation of S ports

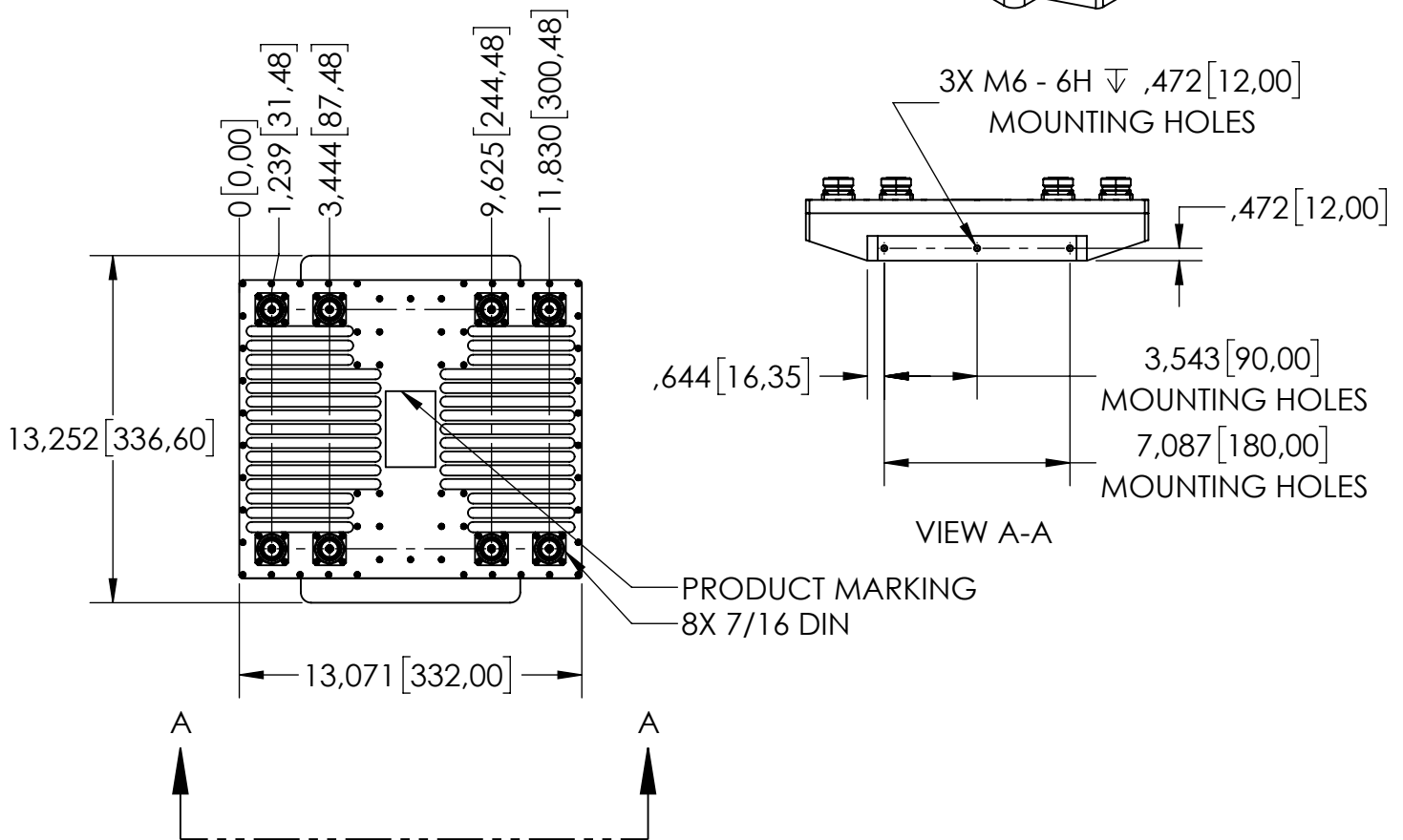
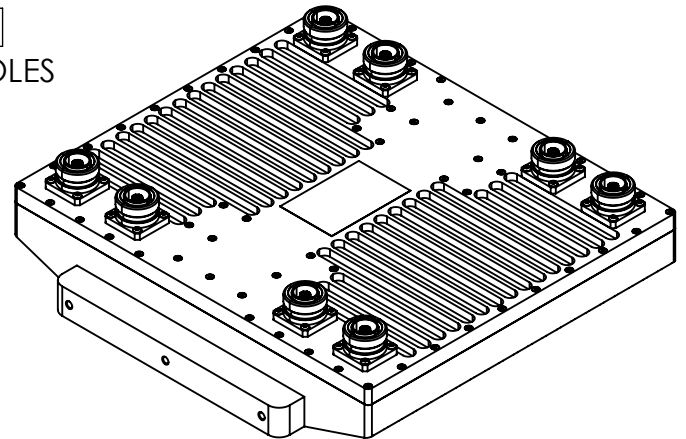
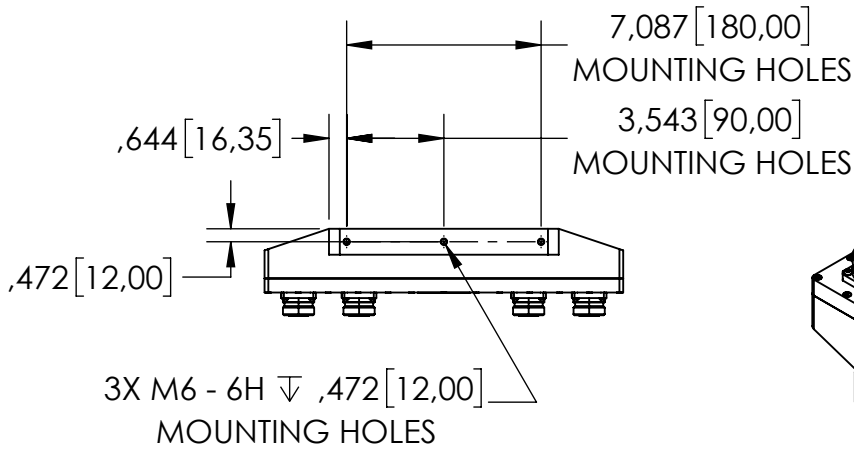

Notes:

1. Case Material: Aluminum
 2. Case Finish: Clear chemical conversion coating, non-chrome or trivalent chrome based.
 3. Dimensions are in inches [mm]. Tolerances: 2 Pl. 0.03 inch; 3 Pl. 0.015 inch
 4. Weight: 9784 grams
 5. Marking may contain other features or characters for internal lot control
- Recommended screws for mounting model: Use M6 cup head or cylindrical head.



P.O. Box 350166, Brooklyn, New York 11235-0003 (718) 934-4500 Fax (718) 332-4661 For detailed performance specs & shopping online see Mini-Circuits web site



The Design Engineers Search Engine Provides ACTUAL Data Instantly From MINI-CIRCUITS At: www.minicircuits.com

RF/IF MICROWAVE COMPONENTS

All Mini-Circuits products are manufactured under exacting quality assurance and control standards, and are capable of meeting published specifications after being subjected to any or all of the following physical and environmental test.

Specification	Test/Inspection Condition	Reference/Spec
Operating Temperature	0° C to +105° C Ambient Environment	Individual Model Datasheet
Storage Temperature	0° C to +105° C Ambient Environment	Individual Model Datasheet
Vibration (High Frequency)	20g peak, 10-2000 Hz, 12 times in each of three perpendicular directions (total 36)	MIL-STD-202, Method 204, Condition D
Mechanical Shock	100g, 6ms sawtooth, 3 shocks each direction 3 axes (total 18)	MIL-STD-202, Method 213, Condition I