

Ultra Low Noise, High IP3

Monolithic Amplifier

CMA-252LN+

50Ω 1.5 to 2.5 GHz

The Big Deal

- Ceramic, Hermetically Sealed, Nitrogen filled
- Low profile case, .045" high
- Ultra Low Noise Figure
- High Gain, High IP3
- Class 1B HBM ESD (500V)



CASE STYLE: DL1721

*MIL Screening Available
Please consult Applications Dept.*

Product Overview

Mini-Circuits CMA-252LN+ is a E-PHEMT based Ultra-Low Noise MMIC Amplifier with a unique combination of low noise and high IP3 making this amplifier ideal for sensitive high dynamic range receiver applications. This design operates on a single 3 to 4V supply. The MMIC amplifier is bonded to a multilayer integrated LTCC substrate and then hermetically sealed under a controlled nitrogen atmosphere with gold-plated covers and eutectic AuSn solder. These amplifiers are capable of meeting MIL requirements for gross leak, fine leak, thermal shock, vibration, acceleration, mechanical shock, and HTOL. The testing can be done if requested.

Key Features

Feature	Advantages
Ultra Low Noise, 0.8 dB at 1.8 GHz	Excellent noise figure performance. Increases signal to noise ratio.
High IP3, +29 dBm at 1.8 GHz	Combining Low Noise and High IP3 makes this MMIC amplifier ideal for use in Low Noise Receiver Front End (RFE) as it gives the user advantages at both ends of the dynamic range: sensitivity & two-tone IM performance.
Adjustable Current	Provides users ability to set current consumption over a wide range from 25 to 80 mA.
Ceramic Hermetic Package	Low inductance, repeatable performance, excellent reliability
Max Input Power, +27 dBm	Ruggedized design operates up to high input powers often seen at Receiver inputs eliminating the need for an external limiter.
High Reliability	Low, small signal operating current of 57 mA nominal maintains junction temperatures typically below 100°C at 85°C ground lead temperature.



Ultra Low Noise, High IP3

Monolithic Amplifier

1.5-2.5 GHz

Product Features

- Low Noise Figure, 0.8 dB at 1.8 GHz
- High IP3, 30 dBm typ. at 1.8 GHz
- P1dB 17 dBm typ. at 1.8 GHz
- Adjustable Current, 25 to 80 mA
- Adjustable Gain, ± 1.5 dB
- Active Bias
- Small size - 3mm x 3mm x 1.14mm
- Ceramic, hermetic, Nitrogen filled
- No external matching components required

Typical Applications

- Base station infrastructure
- Satellite Communication (Inmarsat)
- LTE
- GPS
- Tactical Air Navigation

General Description

The CMA-252LN+ amplifier is fabricated using E-PHEMT technology and offers extremely high dynamic range with ultra low noise figure and good input and output return loss. Terminal finish is Ni-Pd-Au and it has repeatable performance from lot to lot due to fully automated, tightly controlled semiconductor and assembly processes.

simplified schematic and pad description

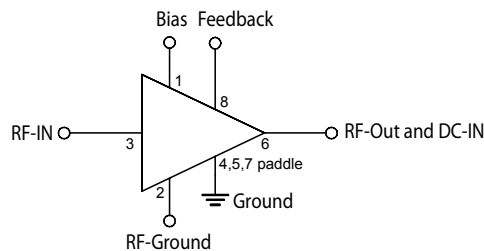

Generic photo used for illustration purposes only

CASE STYLE: DL1721

CMA-252LN+

+RoHS Compliant

The +Suffix identifies RoHS Compliance. See our web site for RoHS Compliance methodologies and qualifications

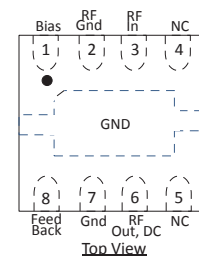

Function	Pad Number	Description
RF IN	3	Connects to RF input via C1 and Pad 2 via L1
RF-OUT	6	Connects to RF out via C2, Pad 8 via R1, and C3
RF-Ground	2	Connects to ground via C4 and Pad 3 via L1
Bias	1	Connects to Supply voltage (Vs) via Rbias
Feedback	8	Connected to pads 6, 1 via R1 and C3
Ground	7 & paddle	Connects to ground
Not connected	4,5	Recommend connection to ground

* Enhancement mode pseudomorphic High Electron Mobility Transistor.



Electrical Specifications⁽¹⁾ at 25°C, unless noted

Parameter	Condition (GHz)	Vs=4V			Vs=3V	Units
		Min.	Typ.	Max.	Typ.	
Frequency Range		1.5		2.5		GHz
Noise Figure	1.5		0.7		0.7	dB
	1.8		0.8		0.9	
	2.0		1.0		1.0	
	2.2		1.1		1.2	
	2.5		1.3		1.3	
Gain	1.5		19.2		18.6	dB
	1.8		18.3		17.6	
	2.0		16.8		16.2	
	2.2		16.1		15.4	
	2.5		15.1		14.2	
Input Return Loss	1.5		19.0		14.0	dB
	1.8		15.0		12.4	
	2.0		13.8		11.8	
	2.2		13.0		11.6	
	2.5		12.5		11.1	
Output Return Loss	1.5		10.0		10.6	dB
	1.8		22.5		26.0	
	2.0		16.5		16.0	
	2.2		11.2		10.8	
	2.5		7.6		7.1	
Output Power @ 1 dB compression ⁽²⁾	1.5		18.5		16.2	dBm
	1.8		17.9		15.9	
	2.0		17.8		15.6	
	2.2		17.4		15.3	
	2.5		16.1		13.9	
Output IP3	1.5		31.1		27.1	dBm
	1.8		30.1		25.5	
	2.0		30.0		25.3	
	2.2		29.3		24.8	
	2.5		27.6		23.2	
Device Operating Voltage		3.8	4.0	4.2	3.0	V
Device Operating Current at typ. voltage ⁽²⁾			57	70	41	mA
DC Current Variation Vs. Temp. at typical voltage ⁽³⁾			-19		-3.4	µA/°C
DC Current Variation Vs. Voltage			0.018		0.017	mA/mV
Thermal Resistance			53		53	°C/W

⁽¹⁾ Measured on Mini-Circuits Characterization test board TB-759+. See Characterization Test Circuit (Fig. 1) R1=825Ω, R_{bias}=619Ω

⁽²⁾ Current increases at P1dB

⁽³⁾ (Current at 85°C - Current at -45°C)/130

Absolute Maximum Ratings⁽⁴⁾

Parameter	Ratings
Operating Temperature (ground lead)	-55°C to 105°C
Storage Temperature	-65°C to 125°C
Junction Temperature	150°C
Total Power Dissipation	0.55 W
Input Power (CW), Vs=3V or 4V	+25 dBm (5 min. max) +20 dBm (continuous)
DC Voltage	5.5V

⁽⁴⁾ Permanent damage may occur if any of these limits are exceeded. Electrical maximum ratings are not intended for continuous normal operation.

DC Current Histogram at Vs=4V

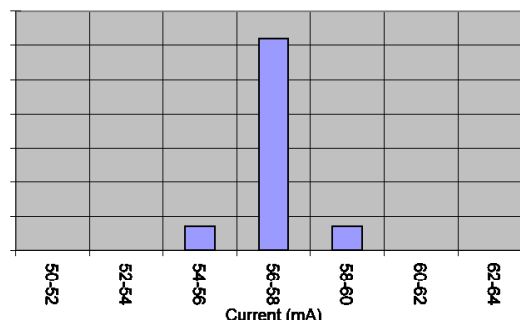

Recommended Application and Characterization Test Circuit

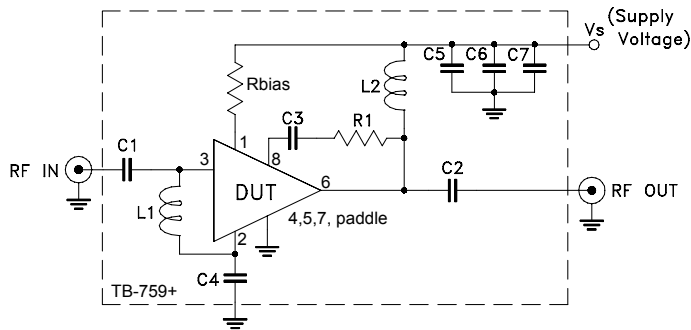

Fig 1. Application and Characterization circuit

Note: This block diagram is used for characterization. (DUT soldered on Mini-Circuits Characterization test board TB-759+)
 Gain, Return loss, Output power at 1dB compression (P1 dB) , output IP3 (OIP3) and noise figure measured using Agilent’s N5242A PNA-X microwave network analyzer.

Conditions:

1. Gain and Return loss: Pin= -25dBm
2. Output IP3 (OIP3): Two tones, spaced 2.5 MHz apart, 2 dBm/tone at output.

Suggested PCB Layout (PL-405)

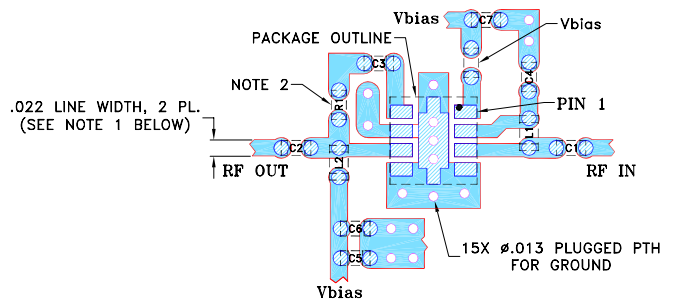
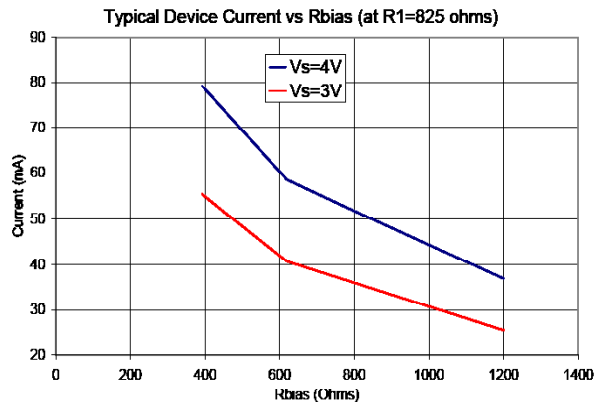

- NOTES: 1. TRACE WIDTH IS SHOWN FOR ROGERS RO4350B WITH DIELECTRIC THICKNESS .010" ± .001"; COPPER: 1/2 OZ. EACH SIDE. FOR OTHER MATERIALS TRACE WIDTH MAY NEED TO BE MODIFIED.
 2. 0402 SIZE CHIP FOOT PRINTS SHOWN FOR REFERENCE, FOR COMPONENT VALUE REFER TO TB-759+.
 3. BOTTOM SIDE OF THE PCB IS CONTINUOUS GROUND PLANE.
- DENOTES PCB COPPER LAYOUT WITH SMOBC (SOLDER MASK OVER BARE COPPER)
 - DENOTES COPPER LAND PATTERN FREE OF SOLDER MASK

Product Marking

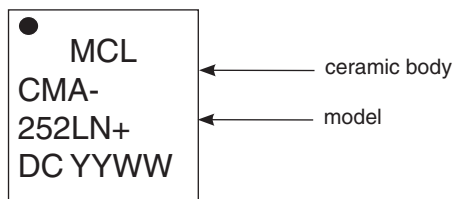

Adjustable Gain Performance (vs. R1) at Vs=4V

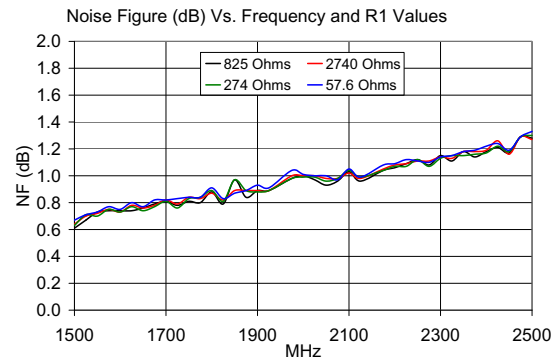
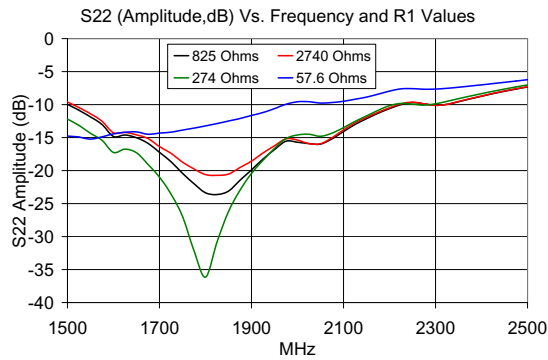
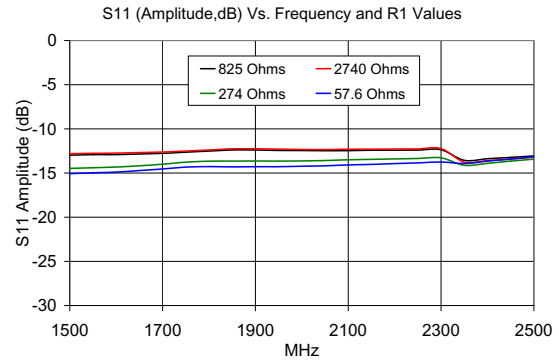
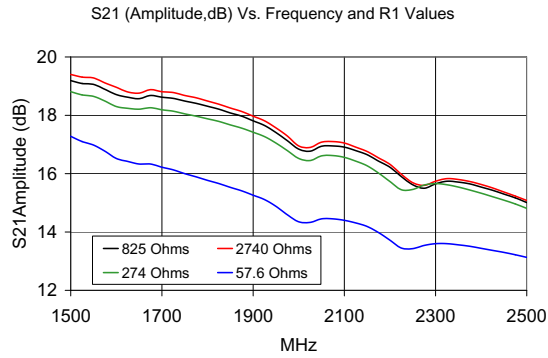

Adjustable Gain Performance (vs. R1) at Vs=3V

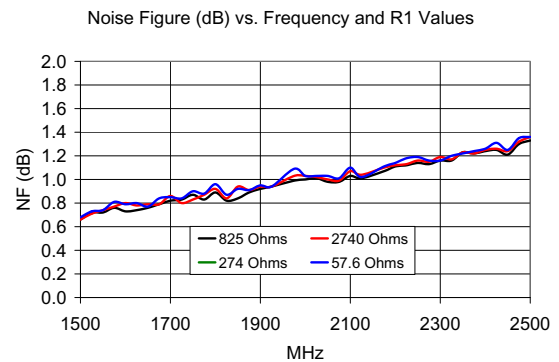
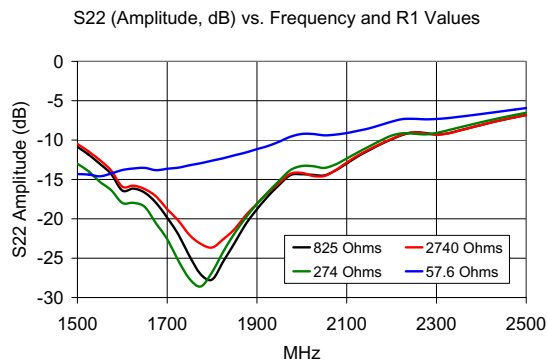
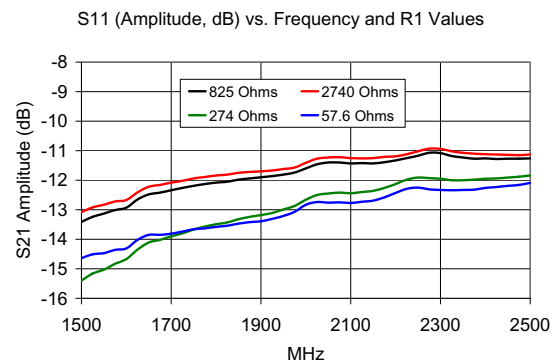
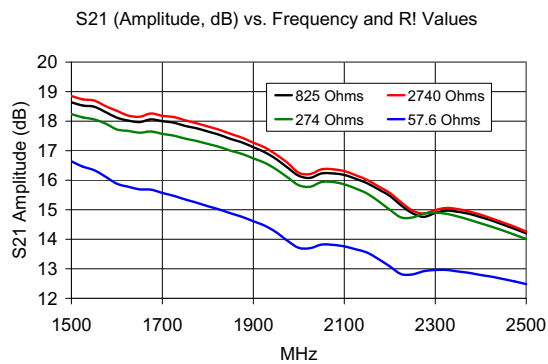

Additional Detailed Technical Information	
<i>additional information is available on our dash board. To access this information click here</i>	
Performance Data	Data Table
	Swept Graphs
	S-Parameter (S2P Files) Data Set (.zip file)
Case Style	DL1721 <i>Ceramic package, exposed paddle, Terminla finish: NiPdAu</i>
Tape & Reel Standard quantities available on reel	F66-1 <i>7" reels with 20, 50, 100, 200, 500 or 1K, 2K devices.</i>
Suggested Layout for PCB Design	PL-406
Evaluation Board	TB-759+
Environmental Ratings	ENV-68

ESD Rating

Human Body Model (HBM): Class 1A (250 to <1000V) in accordance with ANSI/ESD STM 5.1 - 2001

Machine Model (MM): Class M1 (pass 25V) in accordance with ANSI/ESD STM5.2-1999

MSL Rating

Moisture Sensitivity: MSL1 (these parts are hermetic, air cavity and therefore, MSL ratings do not strictly apply. For handling purpose, use MSL1)

Qualification Testing

The table below shows the initial qualification testing performed. If required, parts can be subjected to 100% screening and qualifications testing per MIL standard requirement.

Test Description		Test Method/Process	Results
1	Hermeticity (fine and gross leak)	MIL-STD-202 Method 112, Cond. C & D	Pass
2	Acceleration, 30Kg, Y1 Direction	MIL-STD-883 Method 2001 Cond. E	Pass
3	Vibration , 10-2000Hz sine, 20g, 3 axis	MIL-STD-202 Method 204, Cond. D	Pass
4	Mechanical shock	MIL-STD-202 Method 213, Cond . A	Pass
5	PIND 20G's @130 Hz	MIL-STD-750 Method 2052.2	Pass
6	Temp Cycle -55C/+125C, 1000 Cycles	MIL-STD-202 Method 107	Pass
7	Autoclave, 121C, RH 100%, 15 Psig, 96 hrs	JESD22-A102C	Pass
8	HTOL, 1000hrs, 105C at rated Voltage condition	MIL-STD-202 Method 108, Cond . D	Pass
9	Bend Test	JESD22-B113	Pass
10	Resistance to soldering heat, 3x reflow, 260C peak	JESD22-B102	Pass
11	Drop Test	JESD22-B111	Pass
12	Adhesion Strength	Push Test>10 lb	Pass

Additional Notes

- A. Performance and quality attributes and conditions not expressly stated in this specification document are intended to be excluded and do not form a part of this specification document.
- B. Electrical specifications and performance data contained in this specification document are based on Mini-Circuit's applicable established test performance criteria and measurement instructions.
- C. The parts covered by this specification document are subject to Mini-Circuits standard limited warranty and terms and conditions (collectively, "Standard Terms"); Purchasers of this part are entitled to the rights and benefits contained therein. For a full statement of the Standard Terms and the exclusive rights and remedies thereunder, please visit Mini-Circuits' website at www.minicircuits.com/MCLStore/terms.jsp



Typical Performance Data

NOTE: Use PDF Bookmarks to view DATA at required conditions

Definitions:

Input Return Loss = -S11 (dB)

Gain(Power Gain) = S21 (dB)

Reverse Isolation = -S12 (dB)

Output Return Loss = -S22 (dB)

TEST CONDITIONS: Vd = 4.00V, Id = 58.41mA @ Temperature = +25°C

FREQ	Gain	Isolation	Input Return Loss	Output Return Loss	Stability		IP-3 Output	1dB Comp. Output	Noise Figure
					K	Measure			
(MHz)	(dB)	(dB)	(dB)	(dB)	K	Measure	(dBm)	(dBm)	(dB)
1200.0	18.61	42.33	18.85	3.76	4.43	0.58	29.33	17.34	0.51
1250.0	18.82	41.67	18.91	4.41	4.40	0.64	29.82	17.82	0.59
1300.0	19.03	41.03	18.64	5.19	4.35	0.70	30.43	17.79	0.58
1350.0	19.17	40.51	18.07	6.11	4.35	0.77	30.85	18.39	0.61
1400.0	19.23	40.03	17.53	7.21	4.37	0.82	31.10	18.07	0.60
1450.0	19.22	39.73	16.94	8.44	4.46	0.87	31.60	18.00	0.58
1500.0	19.18	39.45	16.43	9.86	4.53	0.92	31.62	17.94	0.64
1550.0	19.07	39.21	15.94	11.66	4.63	0.95	31.93	18.37	0.75
1600.0	18.76	39.12	15.65	14.35	4.90	0.99	31.99	17.64	0.72
1650.0	18.50	39.20	15.03	15.00	5.10	1.00	32.58	17.73	0.76
1700.0	18.61	38.57	14.71	16.77	4.73	1.01	32.11	17.54	0.80
1750.0	18.49	38.41	14.42	19.50	4.75	1.02	33.10	17.74	0.83
1800.0	18.30	38.30	14.31	22.19	4.82	1.02	33.25	17.77	0.83
1850.0	18.09	38.23	14.02	22.69	4.90	1.03	33.32	18.05	0.83
1900.0	17.84	38.09	13.84	20.12	4.94	1.02	33.24	18.18	0.88
1950.0	17.48	38.08	13.71	17.23	5.10	1.01	32.95	17.32	0.90
2000.0	16.84	38.65	13.46	16.08	5.81	1.01	32.52	17.63	0.93
2050.0	16.96	38.00	13.14	16.56	5.32	1.01	33.05	17.60	0.99
2100.0	16.95	37.70	12.98	14.55	5.08	1.00	32.88	17.44	1.00
2150.0	16.69	37.59	13.01	12.61	5.07	0.98	33.18	17.09	1.10
2200.0	16.28	37.62	12.80	10.90	5.18	0.95	32.21	16.95	1.09
2250.0	15.65	37.82	12.66	10.00	5.58	0.93	32.48	16.51	1.08
2300.0	15.69	37.28	12.42	10.49	5.27	0.94	32.61	16.54	1.13
2350.0	15.78	37.02	12.46	9.89	5.00	0.93	32.98	16.57	1.13
2400.0	15.61	36.94	12.52	9.02	4.94	0.90	32.92	16.27	1.21
2450.0	15.37	36.94	12.44	8.23	4.93	0.88	32.15	16.28	1.19
2500.0	15.08	36.97	12.47	7.57	4.98	0.85	31.50	16.22	1.25
2550.0	14.80	36.87	12.34	7.00	4.93	0.82	31.43	16.41	1.29
2600.0	14.54	36.77	12.36	6.49	4.87	0.80	31.06	16.30	1.32
2650.0	14.26	36.76	12.30	6.06	4.87	0.77	31.74	16.19	1.40
2700.0	13.98	36.59	12.25	5.60	4.76	0.74	31.87	15.64	1.42
2750.0	13.69	36.52	12.19	5.23	4.72	0.72	31.27	15.50	1.43
2800.0	13.39	36.57	12.16	4.91	4.74	0.70	31.14	15.50	1.47
2850.0	13.09	36.54	12.18	4.59	4.72	0.67	30.68	15.45	1.53
2900.0	12.80	36.50	12.11	4.32	4.69	0.65	30.61	15.12	1.55
2950.0	12.49	36.51	12.15	4.07	4.69	0.63	30.74	15.03	1.55
3000.0	12.18	36.76	12.18	3.87	4.85	0.61	31.44	15.04	1.53

Typical Performance Data

Definitions:

Input Return Loss = -S11 (dB)

Gain(Power Gain) = S21 (dB)

Reverse Isolation = -S12 (dB)

Output Return Loss = -S22 (dB)

TEST CONDITIONS: Vd = 3.50V, Id = 50.11mA @ Temperature = +25°C

FREQ	Gain	Isolation	Input Return Loss	Output Return Loss	Stability		IP-3 Output	1dB Comp. Output	Noise Figure
					K	Measure			
(MHz)	(dB)	(dB)	(dB)	(dB)	K	Measure	(dBm)	(dBm)	(dB)
1200.0	18.46	41.38	17.58	3.88	4.09	0.60	28.37	16.30	0.54
1250.0	18.66	40.73	17.32	4.56	4.07	0.66	28.83	16.82	0.59
1300.0	18.85	40.10	16.96	5.37	4.02	0.72	29.47	16.75	0.57
1350.0	18.99	39.62	16.39	6.34	4.04	0.78	29.71	17.39	0.63
1400.0	19.03	39.13	15.88	7.48	4.05	0.84	30.11	17.08	0.59
1450.0	19.02	38.87	15.41	8.78	4.14	0.89	30.65	16.97	0.58
1500.0	18.96	38.60	15.00	10.30	4.22	0.93	30.76	16.94	0.65
1550.0	18.84	38.39	14.60	12.22	4.32	0.97	30.71	17.35	0.76
1600.0	18.52	38.32	14.38	15.12	4.58	1.00	31.05	16.63	0.75
1650.0	18.26	38.40	13.88	15.81	4.76	1.01	31.61	16.68	0.77
1700.0	18.36	37.83	13.61	17.93	4.45	1.02	31.36	16.51	0.82
1750.0	18.22	37.69	13.40	21.20	4.49	1.03	32.40	16.70	0.84
1800.0	18.03	37.60	13.33	24.20	4.57	1.03	32.70	16.73	0.84
1850.0	17.81	37.54	13.09	23.43	4.64	1.03	32.36	16.98	0.83
1900.0	17.56	37.45	12.95	19.82	4.70	1.03	32.08	17.12	0.89
1950.0	17.19	37.46	12.87	16.70	4.86	1.02	32.03	16.27	0.96
2000.0	16.55	38.02	12.67	15.34	5.52	1.01	31.62	16.61	0.98
2050.0	16.66	37.43	12.40	15.74	5.09	1.01	31.85	16.56	1.01
2100.0	16.64	37.20	12.27	13.97	4.91	1.00	31.51	16.42	1.01
2150.0	16.38	37.10	12.32	12.15	4.91	0.98	31.82	16.06	1.10
2200.0	15.96	37.21	12.16	10.53	5.05	0.95	30.76	15.94	1.12
2250.0	15.34	37.43	12.04	9.64	5.43	0.93	30.48	15.47	1.12
2300.0	15.37	36.91	11.84	10.02	5.15	0.94	31.11	15.51	1.16
2350.0	15.45	36.71	11.91	9.47	4.93	0.92	31.17	15.54	1.15
2400.0	15.26	36.67	11.98	8.66	4.89	0.90	30.72	15.26	1.23
2450.0	15.02	36.72	11.92	7.92	4.92	0.87	30.57	15.24	1.19
2500.0	14.72	36.80	11.98	7.30	4.99	0.84	29.62	15.20	1.28
2550.0	14.44	36.74	11.86	6.74	4.95	0.82	29.79	15.38	1.30
2600.0	14.18	36.67	11.89	6.25	4.91	0.79	29.98	15.26	1.33
2650.0	13.89	36.72	11.85	5.85	4.95	0.76	30.41	15.14	1.38
2700.0	13.61	36.59	11.82	5.40	4.85	0.73	30.62	14.60	1.45
2750.0	13.31	36.54	11.78	5.05	4.82	0.71	29.90	14.45	1.42
2800.0	13.02	36.68	11.77	4.74	4.90	0.69	30.08	14.40	1.47
2850.0	12.71	36.66	11.79	4.44	4.87	0.66	29.52	14.39	1.53
2900.0	12.41	36.68	11.73	4.18	4.88	0.64	29.50	14.04	1.55
2950.0	12.11	36.74	11.78	3.93	4.90	0.62	29.73	13.91	1.58
3000.0	11.79	36.99	11.81	3.74	5.06	0.60	30.59	13.96	1.59

Typical Performance Data

Definitions:

Input Return Loss = -S11 (dB)

Gain(Power Gain) = S21 (dB)

Reverse Isolation = -S12 (dB)

Output Return Loss = -S22 (dB)

TEST CONDITIONS: Vd = 4.50V, Id = 66.65mA @ Temperature = +25°C

FREQ	Gain	Isolation	Input Return Loss	Output Return Loss	Stability		IP-3 Output	1dB Comp. Output	Noise Figure
					K	Measure			
(MHz)	(dB)	(dB)	(dB)	(dB)	K	Measure	(dBm)	(dBm)	(dB)
1200.0	18.66	43.29	19.88	3.63	4.83	0.57	30.85	18.05	0.53
1250.0	18.88	42.60	20.21	4.26	4.78	0.63	31.44	18.51	0.59
1300.0	19.09	41.96	20.17	4.99	4.73	0.69	32.27	18.44	0.58
1350.0	19.25	41.41	19.62	5.87	4.72	0.75	32.81	18.95	0.60
1400.0	19.32	40.91	18.95	6.91	4.73	0.80	33.19	18.60	0.59
1450.0	19.33	40.62	18.29	8.07	4.83	0.86	33.99	18.51	0.60
1500.0	19.29	40.31	17.69	9.40	4.90	0.90	33.65	18.49	0.64
1550.0	19.19	40.05	17.07	11.08	5.00	0.94	33.86	18.99	0.75
1600.0	18.89	39.94	16.72	13.56	5.29	0.97	33.61	18.20	0.76
1650.0	18.64	40.01	15.99	14.15	5.50	0.98	34.53	18.32	0.76
1700.0	18.76	39.35	15.60	15.61	5.08	1.00	34.02	18.16	0.81
1750.0	18.64	39.15	15.25	17.92	5.09	1.01	34.07	18.43	0.84
1800.0	18.46	39.02	15.09	20.30	5.15	1.02	34.75	18.51	0.83
1850.0	18.27	38.89	14.74	21.54	5.20	1.02	34.19	18.80	0.82
1900.0	18.02	38.76	14.52	20.22	5.25	1.02	33.76	18.98	0.86
1950.0	17.67	38.71	14.34	17.82	5.40	1.01	33.39	18.13	0.94
2000.0	17.01	39.29	14.05	17.00	6.18	1.01	33.08	18.47	0.99
2050.0	17.15	38.52	13.69	17.60	5.58	1.01	32.96	18.47	0.98
2100.0	17.15	38.19	13.49	15.29	5.30	1.00	32.73	18.32	0.99
2150.0	16.90	38.06	13.50	13.18	5.28	0.98	32.74	17.95	1.10
2200.0	16.50	38.03	13.27	11.35	5.36	0.95	32.17	17.84	1.13
2250.0	15.86	38.19	13.11	10.47	5.76	0.94	32.32	17.40	1.08
2300.0	15.90	37.57	12.83	11.06	5.40	0.95	32.47	17.46	1.16
2350.0	16.02	37.31	12.83	10.42	5.11	0.94	32.48	17.50	1.14
2400.0	15.85	37.21	12.87	9.47	5.03	0.91	32.15	17.18	1.21
2450.0	15.62	37.16	12.77	8.63	5.00	0.89	31.68	17.21	1.19
2500.0	15.33	37.11	12.80	7.93	5.01	0.86	31.17	17.18	1.25
2550.0	15.07	37.00	12.65	7.32	4.95	0.84	30.99	17.37	1.30
2600.0	14.81	36.85	12.65	6.78	4.87	0.81	30.78	17.26	1.33
2650.0	14.54	36.78	12.58	6.33	4.83	0.79	30.79	17.14	1.41
2700.0	14.26	36.57	12.51	5.85	4.70	0.76	31.16	16.59	1.45
2750.0	13.97	36.46	12.47	5.46	4.64	0.73	30.62	16.44	1.42
2800.0	13.68	36.48	12.42	5.12	4.65	0.71	30.70	16.41	1.47
2850.0	13.39	36.41	12.44	4.79	4.61	0.68	30.21	16.38	1.52
2900.0	13.09	36.36	12.35	4.51	4.58	0.66	30.25	16.04	1.54
2950.0	12.79	36.29	12.40	4.24	4.54	0.64	30.54	15.99	1.58
3000.0	12.48	36.42	12.43	4.03	4.63	0.62	31.35	15.96	1.55

Typical Performance Data

Definitions:

Input Return Loss = -S11 (dB)

Gain(Power Gain) = S21 (dB)

Reverse Isolation = -S12 (dB)

Output Return Loss = -S22 (dB)

TEST CONDITIONS: Vd = 4.00V, Id = 58.53mA @ Temperature = -45°C

FREQ	Gain	Isolation	Input Return Loss	Output Return Loss	Stability		IP-3 Output	1dB Comp. Output	Noise Figure
					K	Measure			
(MHz)	(dB)	(dB)	(dB)	(dB)	K	Measure	(dBm)	(dBm)	(dB)
1200.0	19.04	42.69	17.71	3.52	4.24	0.55	29.66	17.61	0.34
1250.0	19.27	42.07	18.74	4.16	4.26	0.62	29.76	18.10	0.37
1300.0	19.49	41.37	19.55	4.88	4.19	0.68	30.09	18.06	0.40
1350.0	19.64	40.82	19.88	5.74	4.19	0.73	30.42	18.68	0.43
1400.0	19.71	40.30	19.76	6.73	4.20	0.79	30.75	18.38	0.37
1450.0	19.73	40.01	19.35	7.82	4.29	0.84	30.70	18.28	0.37
1500.0	19.69	39.66	18.76	9.10	4.33	0.88	30.52	18.25	0.45
1550.0	19.60	39.49	18.18	10.66	4.47	0.92	30.76	18.61	0.53
1600.0	19.30	39.36	17.79	13.03	4.73	0.96	29.93	17.90	0.51
1650.0	19.08	39.41	16.99	13.58	4.89	0.97	30.63	17.97	0.52
1700.0	19.17	38.86	16.52	15.00	4.60	0.98	30.22	17.81	0.55
1750.0	19.08	38.69	16.13	17.05	4.60	1.00	30.13	17.94	0.58
1800.0	18.91	38.36	16.08	19.61	4.57	1.01	30.60	17.97	0.57
1850.0	18.72	38.30	15.70	21.37	4.65	1.01	30.27	18.24	0.54
1900.0	18.47	38.30	15.47	21.02	4.78	1.01	30.15	18.35	0.60
1950.0	18.14	38.33	15.33	18.82	4.96	1.00	29.57	17.48	0.63
2000.0	17.46	38.91	14.86	17.71	5.68	1.00	29.58	17.80	0.70
2050.0	17.65	38.03	14.46	18.48	5.04	1.01	29.64	17.78	0.67
2100.0	17.63	37.91	14.44	15.87	4.92	0.99	29.14	17.64	0.65
2150.0	17.37	37.80	14.37	13.54	4.92	0.97	29.20	17.26	0.70
2200.0	16.98	37.86	14.09	11.59	5.04	0.95	28.68	17.16	0.78
2250.0	16.24	38.11	13.86	10.42	5.51	0.93	28.45	16.68	0.73
2300.0	16.30	37.39	13.48	11.38	5.12	0.95	28.61	16.67	0.77
2350.0	16.50	37.23	13.52	10.83	4.87	0.94	28.49	16.76	0.75
2400.0	16.34	37.15	13.47	9.79	4.80	0.91	28.17	16.44	0.83
2450.0	16.10	37.15	13.30	8.90	4.81	0.89	28.10	16.45	0.82
2500.0	15.82	37.17	13.23	8.13	4.84	0.86	27.60	16.44	0.84
2550.0	15.56	37.00	12.96	7.53	4.75	0.84	27.83	16.61	0.89
2600.0	15.30	37.10	12.97	7.00	4.81	0.82	27.74	16.47	0.94
2650.0	15.04	37.02	12.86	6.49	4.77	0.79	27.27	16.37	0.98
2700.0	14.76	36.91	12.76	5.99	4.69	0.76	27.60	15.84	1.01
2750.0	14.47	36.92	12.64	5.59	4.69	0.74	27.13	15.71	0.95
2800.0	14.18	37.02	12.54	5.25	4.75	0.72	27.95	15.70	1.01
2850.0	13.89	36.96	12.50	4.89	4.70	0.69	26.99	15.65	1.06
2900.0	13.60	37.08	12.43	4.60	4.76	0.67	26.81	15.30	1.06
2950.0	13.31	36.84	12.48	4.30	4.61	0.64	27.14	15.21	1.06
3000.0	13.02	36.91	12.46	4.04	4.63	0.62	28.06	15.28	1.06

Typical Performance Data

Definitions:

Input Return Loss = -S11 (dB)

Gain(Power Gain) = S21 (dB)

Reverse Isolation = -S12 (dB)

Output Return Loss = -S22 (dB)

TEST CONDITIONS: Vd = 3.50V, Id = 49.27mA @ Temperature = -45°C

FREQ	Gain	Isolation	Input Return Loss	Output Return Loss	Stability		IP-3 Output	1dB Comp. Output	Noise Figure
					K	Measure			
(MHz)	(dB)	(dB)	(dB)	(dB)	K	Measure	(dBm)	(dBm)	(dB)
1200.0	18.82	41.70	17.41	3.66	3.95	0.57	27.75	16.27	0.38
1250.0	19.04	41.06	17.90	4.32	3.95	0.63	28.00	16.81	0.40
1300.0	19.25	40.40	18.15	5.09	3.91	0.70	28.56	16.75	0.40
1350.0	19.39	39.86	18.03	6.00	3.91	0.76	28.75	17.38	0.43
1400.0	19.45	39.38	17.67	7.04	3.93	0.81	29.38	17.09	0.39
1450.0	19.44	39.09	17.16	8.20	4.01	0.86	29.56	16.98	0.38
1500.0	19.40	38.79	16.60	9.58	4.07	0.91	29.64	16.94	0.43
1550.0	19.29	38.62	16.15	11.26	4.20	0.94	29.71	17.36	0.52
1600.0	18.98	38.50	15.83	13.82	4.44	0.98	29.50	16.65	0.51
1650.0	18.75	38.57	15.21	14.45	4.60	0.99	30.39	16.70	0.50
1700.0	18.83	38.04	14.85	16.14	4.33	1.00	29.83	16.56	0.55
1750.0	18.72	37.91	14.55	18.59	4.36	1.01	30.37	16.75	0.52
1800.0	18.54	37.61	14.52	21.58	4.35	1.02	31.05	16.77	0.55
1850.0	18.35	37.58	14.23	22.91	4.43	1.02	30.62	17.05	0.55
1900.0	18.09	37.57	14.10	21.04	4.55	1.02	30.40	17.14	0.61
1950.0	17.75	37.63	14.02	18.11	4.73	1.01	30.27	16.33	0.62
2000.0	17.07	38.23	13.66	16.57	5.42	1.01	29.70	16.62	0.65
2050.0	17.25	37.43	13.32	17.19	4.85	1.01	30.12	16.60	0.67
2100.0	17.22	37.31	13.30	14.98	4.75	1.00	29.83	16.47	0.66
2150.0	16.95	37.23	13.30	12.85	4.76	0.97	29.86	16.10	0.70
2200.0	16.55	37.35	13.08	11.05	4.90	0.95	29.16	15.99	0.77
2250.0	15.82	37.63	12.91	9.90	5.36	0.93	28.89	15.50	0.70
2300.0	15.88	36.95	12.58	10.68	5.00	0.95	29.15	15.49	0.79
2350.0	16.05	36.82	12.63	10.19	4.79	0.93	29.44	15.60	0.77
2400.0	15.88	36.75	12.63	9.24	4.73	0.91	28.99	15.29	0.82
2450.0	15.63	36.80	12.52	8.42	4.76	0.88	28.94	15.27	0.82
2500.0	15.34	36.85	12.48	7.71	4.80	0.85	28.30	15.24	0.86
2550.0	15.08	36.71	12.27	7.14	4.73	0.83	28.59	15.40	0.86
2600.0	14.81	36.85	12.31	6.64	4.81	0.81	28.35	15.26	0.91
2650.0	14.54	36.82	12.24	6.16	4.79	0.78	28.31	15.13	0.98
2700.0	14.26	36.76	12.18	5.69	4.74	0.75	28.56	14.58	0.99
2750.0	13.96	36.80	12.09	5.31	4.76	0.73	27.93	14.49	0.95
2800.0	13.67	36.97	12.04	4.99	4.85	0.70	28.06	14.48	1.02
2850.0	13.38	36.91	12.01	4.65	4.80	0.68	27.67	14.40	1.05
2900.0	13.08	37.08	11.98	4.37	4.88	0.65	27.46	14.04	1.08
2950.0	12.78	36.90	12.05	4.09	4.76	0.63	27.87	13.96	1.05
3000.0	12.50	37.00	12.04	3.84	4.79	0.60	28.83	14.02	1.04

Typical Performance Data

Definitions:

Input Return Loss = -S11 (dB)

Gain(Power Gain) = S21 (dB)

Reverse Isolation = -S12 (dB)

Output Return Loss = -S22 (dB)

TEST CONDITIONS: Vd = 4.50V, Id = 68.00mA @ Temperature = -45°C

FREQ	Gain	Isolation	Input Return Loss	Output Return Loss	Stability		IP-3 Output	1dB Comp. Output	Noise Figure
					K	Measure			
(MHz)	(dB)	(dB)	(dB)	(dB)	K	Measure	(dBm)	(dBm)	(dB)
1200.0	19.05	43.75	18.11	3.39	4.67	0.54	32.45	18.40	0.37
1250.0	19.28	43.11	19.35	3.99	4.68	0.60	31.69	18.87	0.39
1300.0	19.51	42.41	20.51	4.68	4.61	0.66	31.63	18.84	0.38
1350.0	19.67	41.82	21.24	5.49	4.60	0.72	31.91	19.37	0.40
1400.0	19.76	41.28	21.39	6.42	4.59	0.77	31.51	19.07	0.38
1450.0	19.78	41.00	20.93	7.44	4.70	0.82	31.08	18.98	0.37
1500.0	19.76	40.66	20.29	8.63	4.76	0.87	30.63	18.97	0.44
1550.0	19.68	40.45	19.57	10.07	4.89	0.91	31.45	19.37	0.54
1600.0	19.39	40.28	19.10	12.26	5.17	0.95	29.98	18.63	0.51
1650.0	19.16	40.35	18.17	12.76	5.36	0.96	30.10	18.75	0.52
1700.0	19.27	39.73	17.62	13.94	4.99	0.97	29.81	18.56	0.56
1750.0	19.19	39.52	17.09	15.69	4.98	0.99	29.88	18.75	0.56
1800.0	19.03	39.18	17.01	17.88	4.94	1.00	30.13	18.76	0.57
1850.0	18.85	39.09	16.53	19.65	5.01	1.00	30.22	19.05	0.54
1900.0	18.61	39.04	16.25	20.33	5.13	1.01	30.19	19.15	0.61
1950.0	18.28	39.06	16.08	19.19	5.32	1.00	29.28	18.24	0.63
2000.0	17.59	39.62	15.57	18.95	6.12	1.01	29.66	18.61	0.66
2050.0	17.79	38.61	15.10	19.80	5.33	1.01	29.61	18.55	0.70
2100.0	17.80	38.49	15.01	16.70	5.20	1.00	29.15	18.40	0.65
2150.0	17.54	38.35	14.95	14.21	5.18	0.98	28.96	18.02	0.79
2200.0	17.16	38.32	14.62	12.12	5.27	0.96	28.54	17.88	0.80
2250.0	16.40	38.55	14.39	10.96	5.77	0.94	28.36	17.43	0.73
2300.0	16.47	37.75	13.96	12.12	5.31	0.96	28.25	17.45	0.78
2350.0	16.70	37.59	13.96	11.51	5.04	0.95	28.11	17.50	0.78
2400.0	16.55	37.46	13.87	10.35	4.94	0.93	27.74	17.18	0.84
2450.0	16.32	37.41	13.67	9.39	4.92	0.90	27.87	17.19	0.81
2500.0	16.04	37.37	13.60	8.56	4.91	0.88	27.50	17.17	0.85
2550.0	15.80	37.15	13.31	7.92	4.80	0.86	27.94	17.33	0.89
2600.0	15.54	37.22	13.31	7.36	4.85	0.83	27.83	17.17	0.93
2650.0	15.28	37.09	13.18	6.83	4.78	0.81	27.45	17.07	1.01
2700.0	15.02	36.92	13.06	6.29	4.67	0.78	27.12	16.53	1.03
2750.0	14.73	36.90	12.95	5.87	4.66	0.76	26.71	16.35	0.97
2800.0	14.44	36.94	12.85	5.51	4.69	0.73	26.88	16.36	0.99
2850.0	14.16	36.85	12.78	5.14	4.63	0.71	27.26	16.31	1.05
2900.0	13.87	36.92	12.73	4.82	4.67	0.68	26.55	15.96	1.06
2950.0	13.58	36.63	12.78	4.51	4.50	0.66	27.10	15.87	1.08
3000.0	13.30	36.62	12.76	4.23	4.47	0.63	28.10	15.92	1.05

Typical Performance Data

Definitions:

Input Return Loss = -S11 (dB)

Gain(Power Gain) = S21 (dB)

Reverse Isolation = -S12 (dB)

Output Return Loss = -S22 (dB)

TEST CONDITIONS: Vd = 4.00V, Id = 58.92mA @ Temperature = +85°C

FREQ	Gain	Isolation	Input Return Loss	Output Return Loss	Stability		IP-3 Output	1dB Comp. Output	Noise Figure
					K	Measure			
(MHz)	(dB)	(dB)	(dB)	(dB)	K	Measure	(dBm)	(dBm)	(dB)
1200.0	18.17	42.61	17.88	3.88	4.87	0.60	27.82	17.10	0.71
1250.0	18.38	41.95	17.46	4.51	4.79	0.66	28.38	17.52	0.75
1300.0	18.60	41.31	16.96	5.29	4.71	0.72	28.59	17.47	0.78
1350.0	18.74	40.78	16.35	6.26	4.71	0.78	29.11	18.03	0.80
1400.0	18.80	40.33	15.81	7.38	4.73	0.84	29.30	17.70	0.78
1450.0	18.79	40.03	15.35	8.64	4.82	0.89	29.52	17.63	0.77
1500.0	18.74	39.71	14.94	10.12	4.88	0.93	29.10	17.64	0.85
1550.0	18.63	39.50	14.54	11.95	4.99	0.97	30.38	18.07	0.94
1600.0	18.37	39.38	14.34	14.64	5.24	1.00	29.63	17.32	0.96
1650.0	18.04	39.59	13.86	15.74	5.59	1.01	29.76	17.47	0.98
1700.0	18.14	38.97	13.57	17.20	5.17	1.02	29.30	17.29	1.03
1750.0	18.03	38.81	13.31	19.65	5.18	1.03	30.05	17.49	1.07
1800.0	17.85	38.63	13.20	21.97	5.21	1.03	30.25	17.56	1.07
1850.0	17.64	38.44	12.98	21.78	5.22	1.04	30.98	17.83	1.06
1900.0	17.39	38.35	12.83	19.50	5.29	1.03	31.62	17.98	1.12
1950.0	17.05	38.41	12.74	16.95	5.49	1.02	30.91	17.12	1.20
2000.0	16.46	38.82	12.56	15.13	6.08	1.01	31.49	17.55	1.24
2050.0	16.30	38.40	12.17	15.96	5.91	1.02	31.34	17.34	1.26
2100.0	16.47	37.89	12.06	14.75	5.42	1.01	31.70	17.20	1.25
2150.0	16.25	37.73	12.14	12.65	5.36	0.99	31.64	16.87	1.40
2200.0	15.85	37.75	11.97	11.01	5.48	0.96	31.66	16.73	1.39
2250.0	15.28	38.02	11.90	10.10	5.90	0.94	31.33	16.39	1.39
2300.0	15.23	37.33	11.68	10.29	5.50	0.95	31.31	16.45	1.45
2350.0	15.31	37.14	11.69	9.79	5.27	0.94	31.62	16.44	1.48
2400.0	15.15	37.06	11.76	8.95	5.20	0.91	31.73	16.12	1.54
2450.0	14.90	37.05	11.73	8.20	5.21	0.88	32.80	16.15	1.56
2500.0	14.62	36.95	11.74	7.51	5.16	0.86	33.37	16.09	1.60
2550.0	14.35	36.84	11.60	6.95	5.09	0.83	33.95	16.28	1.66
2600.0	14.05	36.84	11.69	6.47	5.13	0.80	34.68	16.17	1.70
2650.0	13.79	36.65	11.67	6.02	5.01	0.78	35.40	16.08	1.80
2700.0	13.51	36.49	11.63	5.57	4.90	0.75	36.85	15.49	1.83
2750.0	13.20	36.42	11.63	5.21	4.87	0.73	37.65	15.40	1.83
2800.0	12.90	36.53	11.65	4.90	4.94	0.70	37.23	15.35	1.86
2850.0	12.61	36.30	11.66	4.58	4.79	0.68	36.86	15.31	1.96
2900.0	12.31	36.33	11.63	4.32	4.81	0.65	37.22	15.05	1.98
2950.0	12.00	36.09	11.67	4.05	4.67	0.63	36.58	14.98	1.99
3000.0	11.70	35.97	11.68	3.83	4.60	0.61	35.97	14.91	2.01

Typical Performance Data

Definitions:

Input Return Loss = -S11 (dB)

Gain(Power Gain) = S21 (dB)

Reverse Isolation = -S12 (dB)

Output Return Loss = -S22 (dB)

TEST CONDITIONS: Vd = 3.50V, Id = 50.49mA @ Temperature = +85°C

FREQ	Gain	Isolation	Input Return Loss	Output Return Loss	Stability		IP-3 Output	1dB Comp. Output	Noise Figure
					K	Measure			
(MHz)	(dB)	(dB)	(dB)	(dB)	K	Measure	(dBm)	(dBm)	(dB)
1200.0	18.00	41.76	16.41	3.98	4.54	0.61	27.99	16.24	0.73
1250.0	18.20	41.14	15.92	4.64	4.48	0.67	28.72	16.67	0.76
1300.0	18.41	40.51	15.47	5.45	4.41	0.74	29.27	16.62	0.75
1350.0	18.54	39.99	14.94	6.46	4.42	0.80	29.60	17.24	0.81
1400.0	18.59	39.55	14.49	7.63	4.44	0.86	30.13	16.93	0.80
1450.0	18.57	39.26	14.10	8.95	4.53	0.91	30.62	16.84	0.78
1500.0	18.51	38.99	13.76	10.51	4.60	0.95	30.80	16.83	0.84
1550.0	18.39	38.79	13.43	12.46	4.71	0.99	31.06	17.19	0.95
1600.0	18.12	38.70	13.29	15.35	4.96	1.01	31.78	16.51	0.96
1650.0	17.79	38.89	12.88	16.53	5.28	1.03	31.91	16.61	0.99
1700.0	17.88	38.32	12.66	18.28	4.92	1.03	31.87	16.42	1.03
1750.0	17.77	38.20	12.43	21.09	4.94	1.04	32.26	16.60	1.04
1800.0	17.57	38.06	12.36	23.36	4.99	1.05	32.82	16.65	1.08
1850.0	17.36	37.89	12.19	22.10	5.01	1.04	33.24	16.92	1.16
1900.0	17.09	37.83	12.08	19.17	5.10	1.04	33.60	17.06	1.15
1950.0	16.76	37.91	12.01	16.48	5.30	1.03	35.20	16.23	1.20
2000.0	16.16	38.33	11.86	14.59	5.87	1.02	34.24	16.65	1.25
2050.0	16.00	37.99	11.51	15.23	5.75	1.02	34.12	16.44	1.26
2100.0	16.16	37.53	11.44	14.17	5.32	1.01	35.65	16.33	1.26
2150.0	15.94	37.37	11.53	12.21	5.26	0.99	36.57	16.00	1.40
2200.0	15.53	37.45	11.40	10.66	5.40	0.96	35.28	15.84	1.41
2250.0	14.96	37.76	11.32	9.76	5.84	0.94	35.77	15.47	1.40
2300.0	14.90	37.12	11.15	9.89	5.47	0.95	36.17	15.51	1.47
2350.0	14.98	36.95	11.18	9.41	5.26	0.93	38.22	15.50	1.49
2400.0	14.80	36.90	11.26	8.62	5.22	0.91	37.08	15.21	1.56
2450.0	14.55	36.95	11.24	7.91	5.25	0.88	35.02	15.20	1.57
2500.0	14.27	36.89	11.27	7.25	5.23	0.85	32.73	15.14	1.60
2550.0	13.99	36.81	11.16	6.71	5.18	0.82	33.94	15.34	1.65
2600.0	13.69	36.85	11.27	6.25	5.24	0.80	33.40	15.22	1.70
2650.0	13.42	36.72	11.24	5.82	5.16	0.77	33.91	15.10	1.80
2700.0	13.14	36.60	11.23	5.39	5.06	0.74	33.77	14.53	1.87
2750.0	12.83	36.55	11.24	5.04	5.04	0.72	32.96	14.40	1.83
2800.0	12.52	36.71	11.25	4.75	5.14	0.69	32.73	14.33	1.90
2850.0	12.23	36.49	11.27	4.43	5.00	0.67	31.84	14.32	1.95
2900.0	11.93	36.58	11.26	4.18	5.04	0.65	32.17	14.04	1.98
2950.0	11.62	36.36	11.30	3.93	4.91	0.62	32.02	13.96	2.01
3000.0	11.32	36.26	11.29	3.71	4.84	0.60	32.54	13.89	2.02

Typical Performance Data

Definitions:

Input Return Loss = -S11 (dB)

Gain(Power Gain) = S21 (dB)

Reverse Isolation = -S12 (dB)

Output Return Loss = -S22 (dB)

TEST CONDITIONS: Vd = 4.50V, Id = 67.13mA @ Temperature = +85°C

FREQ	Gain	Isolation	Input Return Loss	Output Return Loss	Stability		IP-3 Output	1dB Comp. Output	Noise Figure
					K	Measure			
(MHz)	(dB)	(dB)	(dB)	(dB)	K	Measure	(dBm)	(dBm)	(dB)
1200.0	18.21	43.68	19.25	3.75	5.39	0.58	29.19	17.64	0.73
1250.0	18.43	43.03	18.88	4.34	5.30	0.64	29.76	18.01	0.77
1300.0	18.66	42.34	18.38	5.09	5.19	0.70	30.02	17.95	0.76
1350.0	18.81	41.79	17.69	6.00	5.18	0.76	30.81	18.43	0.79
1400.0	18.88	41.32	17.06	7.05	5.20	0.82	30.84	18.09	0.80
1450.0	18.89	41.02	16.47	8.24	5.30	0.87	31.31	18.00	0.78
1500.0	18.85	40.68	15.97	9.61	5.35	0.91	30.86	18.00	0.84
1550.0	18.75	40.41	15.51	11.29	5.45	0.95	31.89	18.48	0.95
1600.0	18.49	40.32	15.24	13.75	5.74	0.99	31.25	17.69	0.95
1650.0	18.16	40.48	14.70	14.74	6.10	1.00	31.47	17.86	0.99
1700.0	18.28	39.81	14.35	15.90	5.61	1.01	31.26	17.70	1.04
1750.0	18.18	39.61	14.02	17.94	5.59	1.02	32.31	17.97	1.06
1800.0	18.01	39.41	13.89	20.08	5.61	1.03	32.50	18.06	1.06
1850.0	17.81	39.16	13.63	20.81	5.58	1.03	32.52	18.37	1.08
1900.0	17.56	39.02	13.44	19.63	5.63	1.03	33.11	18.56	1.13
1950.0	17.24	39.06	13.31	17.52	5.83	1.02	32.20	17.73	1.20
2000.0	16.64	39.45	13.12	15.93	6.47	1.01	32.35	18.21	1.22
2050.0	16.47	38.93	12.67	17.09	6.22	1.02	32.23	18.02	1.27
2100.0	16.67	38.35	12.53	15.62	5.65	1.01	32.34	17.89	1.27
2150.0	16.46	38.15	12.58	13.30	5.56	0.99	32.53	17.57	1.40
2200.0	16.07	38.12	12.40	11.55	5.66	0.97	31.90	17.46	1.40
2250.0	15.49	38.37	12.31	10.64	6.10	0.95	31.81	17.09	1.38
2300.0	15.44	37.61	12.06	10.91	5.64	0.96	31.92	17.17	1.48
2350.0	15.55	37.40	12.05	10.38	5.38	0.95	32.04	17.18	1.46
2400.0	15.40	37.25	12.09	9.46	5.27	0.92	32.12	16.88	1.58
2450.0	15.16	37.20	12.04	8.64	5.25	0.90	32.38	16.90	1.55
2500.0	14.89	37.04	12.05	7.90	5.16	0.87	31.85	16.82	1.59
2550.0	14.63	36.89	11.90	7.31	5.08	0.85	32.11	17.05	1.65
2600.0	14.33	36.85	11.98	6.80	5.09	0.82	32.10	16.93	1.70
2650.0	14.07	36.60	11.95	6.32	4.95	0.79	32.64	16.84	1.78
2700.0	13.80	36.40	11.92	5.85	4.82	0.77	33.21	16.24	1.85
2750.0	13.50	36.31	11.91	5.47	4.77	0.74	32.84	16.13	1.84
2800.0	13.20	36.34	11.91	5.14	4.80	0.72	32.56	16.09	1.89
2850.0	12.92	36.10	11.93	4.80	4.66	0.69	32.42	16.04	1.95
2900.0	12.62	36.07	11.89	4.52	4.64	0.67	32.64	15.82	1.97
2950.0	12.32	35.78	11.93	4.24	4.48	0.65	32.67	15.75	1.99
3000.0	12.02	35.62	11.93	4.00	4.39	0.62	33.75	15.65	1.99

Typical Performance Data

NOTE: Use PDF Bookmarks to view DATA at required conditions

Definitions:

Input Return Loss = -S11 (dB)

Gain(Power Gain) = S21 (dB)

Reverse Isolation = -S12 (dB)

Output Return Loss = -S22 (dB)

TEST CONDITIONS: Vd = 3.00V, Is = 40.95mA @ Temperature = +25°C

FREQ	Gain	Isolation	Input Return Loss	Output Return Loss	Stability		IP-3 Output	1dB Comp. Output	Noise Figure
					K	Measure			
(MHz)	(dB)	(dB)	(dB)	(dB)	K	Measure	(dBm)	(dBm)	(dB)
1200.0	18.17	40.35	15.79	4.00	3.78	0.61	27.33	14.79	0.56
1250.0	18.36	39.73	15.34	4.71	3.77	0.68	27.90	15.30	0.62
1300.0	18.54	39.13	14.93	5.56	3.74	0.75	28.21	15.26	0.62
1350.0	18.65	38.66	14.43	6.57	3.76	0.81	28.57	15.91	0.62
1400.0	18.68	38.21	14.00	7.77	3.78	0.87	29.07	15.64	0.63
1450.0	18.65	37.95	13.62	9.13	3.87	0.92	29.34	15.62	0.60
1500.0	18.59	37.70	13.30	10.75	3.95	0.96	29.00	15.58	0.68
1550.0	18.45	37.51	13.01	12.81	4.05	0.99	29.43	16.06	0.78
1600.0	18.13	37.48	12.85	15.94	4.31	1.02	28.69	15.36	0.76
1650.0	17.87	37.58	12.44	16.68	4.48	1.03	29.15	15.41	0.80
1700.0	17.94	37.04	12.26	19.27	4.22	1.04	28.88	15.26	0.84
1750.0	17.80	36.92	12.10	23.29	4.26	1.05	29.51	15.50	0.88
1800.0	17.59	36.85	12.06	26.34	4.34	1.05	29.74	15.52	0.86
1850.0	17.37	36.82	11.91	23.50	4.43	1.05	29.47	15.77	0.86
1900.0	17.11	36.76	11.82	19.26	4.50	1.04	29.40	15.90	0.93
1950.0	16.73	36.79	11.77	16.10	4.66	1.02	28.03	15.10	0.96
2000.0	16.10	37.35	11.60	14.64	5.28	1.02	28.31	15.37	1.01
2050.0	16.21	36.83	11.39	14.95	4.92	1.02	28.26	15.36	1.03
2100.0	16.17	36.65	11.33	13.37	4.77	1.00	27.93	15.23	1.01
2150.0	15.90	36.57	11.39	11.68	4.78	0.98	27.60	14.87	1.19
2200.0	15.48	36.73	11.27	10.16	4.95	0.95	26.87	14.75	1.16
2250.0	14.87	36.99	11.18	9.27	5.33	0.93	26.62	14.28	1.12
2300.0	14.89	36.54	11.02	9.58	5.09	0.94	26.68	14.30	1.22
2350.0	14.95	36.35	11.12	9.05	4.89	0.92	26.62	14.33	1.16
2400.0	14.76	36.35	11.20	8.30	4.88	0.89	26.09	14.04	1.24
2450.0	14.51	36.44	11.19	7.60	4.92	0.86	26.12	14.03	1.25
2500.0	14.20	36.60	11.26	7.01	5.04	0.84	25.52	13.98	1.28
2550.0	13.92	36.55	11.15	6.48	5.01	0.81	26.39	14.16	1.35
2600.0	13.65	36.54	11.21	6.01	5.00	0.78	26.83	14.03	1.38
2650.0	13.37	36.66	11.18	5.62	5.07	0.76	27.20	13.89	1.46
2700.0	13.08	36.57	11.19	5.20	5.00	0.73	27.29	13.37	1.49
2750.0	12.78	36.56	11.16	4.86	4.99	0.70	26.61	13.23	1.48
2800.0	12.48	36.77	11.16	4.57	5.10	0.68	26.81	13.19	1.54
2850.0	12.18	36.79	11.20	4.27	5.10	0.65	26.57	13.14	1.63
2900.0	11.87	36.86	11.14	4.03	5.13	0.63	26.41	12.79	1.62
2950.0	11.56	37.00	11.21	3.79	5.21	0.61	26.87	12.66	1.62
3000.0	11.25	37.32	11.23	3.61	5.42	0.59	27.86	12.70	1.62

Typical Performance Data

Definitions:

Input Return Loss = -S11 (dB)

Gain(Power Gain) = S21 (dB)

Reverse Isolation = -S12 (dB)

Output Return Loss = -S22 (dB)

TEST CONDITIONS: Vd = 2.70V, Is = 37.12mA @ Temperature = +25°C

FREQ	Gain	Isolation	Input Return Loss	Output Return Loss	Stability		IP-3 Output	1dB Comp. Output	Noise Figure
					K	Measure			
(MHz)	(dB)	(dB)	(dB)	(dB)	K	Measure	(dBm)	(dBm)	(dB)
1200.0	17.96	39.63	14.58	4.09	3.58	0.63	26.24	13.70	0.54
1250.0	18.14	39.04	14.10	4.82	3.57	0.70	26.58	14.22	0.60
1300.0	18.31	38.44	13.69	5.69	3.54	0.76	26.79	14.20	0.59
1350.0	18.41	38.00	13.23	6.73	3.56	0.83	27.27	14.85	0.62
1400.0	18.43	37.56	12.85	7.96	3.59	0.89	27.35	14.62	0.62
1450.0	18.40	37.32	12.53	9.37	3.69	0.93	27.43	14.63	0.60
1500.0	18.32	37.08	12.29	11.05	3.76	0.98	26.92	14.61	0.68
1550.0	18.17	36.93	12.04	13.22	3.88	1.01	27.65	15.14	0.78
1600.0	17.84	36.89	11.93	16.51	4.12	1.03	26.47	14.44	0.75
1650.0	17.58	36.97	11.56	17.27	4.28	1.04	26.83	14.49	0.78
1700.0	17.65	36.49	11.41	20.25	4.05	1.05	26.55	14.38	0.86
1750.0	17.50	36.39	11.30	25.00	4.10	1.06	26.98	14.64	0.87
1800.0	17.29	36.31	11.28	27.68	4.18	1.06	27.04	14.64	0.87
1850.0	17.06	36.32	11.16	23.24	4.28	1.06	26.90	14.87	0.86
1900.0	16.80	36.27	11.09	18.83	4.36	1.05	26.82	15.05	0.94
1950.0	16.42	36.32	11.06	15.71	4.52	1.03	25.68	14.23	0.96
2000.0	15.79	36.87	10.93	14.21	5.11	1.02	25.95	14.52	1.00
2050.0	15.89	36.39	10.76	14.47	4.78	1.03	25.91	14.50	1.05
2100.0	15.84	36.25	10.70	13.00	4.66	1.01	25.59	14.39	1.03
2150.0	15.57	36.18	10.78	11.38	4.68	0.98	25.29	14.02	1.19
2200.0	15.15	36.37	10.67	9.92	4.86	0.95	24.69	13.91	1.17
2250.0	14.54	36.65	10.60	9.05	5.23	0.93	24.42	13.42	1.13
2300.0	14.56	36.24	10.48	9.30	5.02	0.94	24.52	13.43	1.22
2350.0	14.61	36.06	10.58	8.80	4.83	0.92	24.35	13.45	1.19
2400.0	14.41	36.08	10.68	8.08	4.84	0.89	23.92	13.19	1.26
2450.0	14.16	36.20	10.67	7.40	4.90	0.86	23.98	13.16	1.28
2500.0	13.85	36.39	10.74	6.83	5.03	0.83	23.87	13.11	1.32
2550.0	13.57	36.38	10.68	6.32	5.02	0.81	24.24	13.29	1.38
2600.0	13.30	36.39	10.73	5.86	5.02	0.78	25.08	13.14	1.40
2650.0	13.01	36.54	10.71	5.48	5.11	0.75	25.42	13.00	1.48
2700.0	12.72	36.49	10.72	5.07	5.06	0.72	25.58	12.45	1.53
2750.0	12.42	36.53	10.70	4.74	5.07	0.70	25.03	12.34	1.53
2800.0	12.12	36.77	10.72	4.46	5.21	0.67	25.18	12.28	1.53
2850.0	11.82	36.83	10.75	4.17	5.23	0.65	24.97	12.23	1.60
2900.0	11.51	36.93	10.71	3.93	5.27	0.62	24.83	11.87	1.66
2950.0	11.20	37.10	10.77	3.70	5.37	0.60	25.32	11.72	1.62
3000.0	10.89	37.49	10.80	3.52	5.63	0.58	26.33	11.72	1.65

Typical Performance Data

Definitions:

Input Return Loss = -S11 (dB)

Gain(Power Gain) = S21 (dB)

Reverse Isolation = -S12 (dB)

Output Return Loss = -S22 (dB)

TEST CONDITIONS: Vd = 3.30V, Is = 47.19mA @ Temperature = +25°C

FREQ	Gain	Isolation	Input Return Loss	Output Return Loss	Stability		IP-3 Output	1dB Comp. Output	Noise Figure
					K	Measure			
(MHz)	(dB)	(dB)	(dB)	(dB)	K	Measure	(dBm)	(dBm)	(dB)
1200.0	18.39	40.97	16.97	3.93	3.96	0.60	28.08	15.74	0.52
1250.0	18.58	40.32	16.65	4.63	3.93	0.67	28.53	16.25	0.57
1300.0	18.77	39.70	16.23	5.45	3.89	0.73	29.02	16.18	0.59
1350.0	18.90	39.23	15.69	6.44	3.91	0.79	29.39	16.84	0.59
1400.0	18.94	38.75	15.22	7.61	3.92	0.85	29.83	16.52	0.57
1450.0	18.92	38.49	14.79	8.92	4.02	0.90	30.28	16.46	0.58
1500.0	18.86	38.24	14.43	10.49	4.09	0.94	30.42	16.42	0.66
1550.0	18.73	38.03	14.05	12.47	4.19	0.98	30.33	16.85	0.75
1600.0	18.41	37.97	13.87	15.47	4.45	1.01	30.37	16.13	0.74
1650.0	18.15	38.04	13.37	16.18	4.62	1.02	31.14	16.18	0.78
1700.0	18.24	37.51	13.16	18.48	4.34	1.03	30.85	16.01	0.79
1750.0	18.10	37.38	12.97	22.04	4.38	1.04	31.51	16.24	0.82
1800.0	17.90	37.29	12.91	25.13	4.46	1.04	32.31	16.25	0.88
1850.0	17.68	37.24	12.70	23.56	4.53	1.04	31.84	16.48	0.85
1900.0	17.42	37.17	12.59	19.62	4.61	1.03	31.71	16.65	0.87
1950.0	17.05	37.19	12.52	16.46	4.76	1.02	30.77	15.81	0.92
2000.0	16.41	37.75	12.32	15.03	5.40	1.01	30.58	16.12	1.02
2050.0	16.52	37.17	12.07	15.39	4.99	1.02	30.74	16.09	0.98
2100.0	16.50	36.98	11.97	13.71	4.83	1.00	30.43	15.95	0.98
2150.0	16.23	36.88	12.04	11.95	4.83	0.97	30.29	15.58	1.09
2200.0	15.82	37.01	11.88	10.37	4.99	0.95	29.32	15.48	1.11
2250.0	15.20	37.24	11.76	9.47	5.36	0.93	29.15	15.02	1.09
2300.0	15.22	36.76	11.58	9.82	5.10	0.94	29.45	15.03	1.15
2350.0	15.29	36.56	11.67	9.29	4.89	0.92	29.51	15.07	1.14
2400.0	15.10	36.54	11.73	8.50	4.87	0.89	28.78	14.78	1.23
2450.0	14.86	36.60	11.70	7.78	4.90	0.87	28.79	14.78	1.20
2500.0	14.56	36.70	11.76	7.17	4.98	0.84	28.07	14.72	1.25
2550.0	14.28	36.67	11.65	6.63	4.96	0.81	28.46	14.93	1.31
2600.0	14.01	36.62	11.69	6.15	4.93	0.78	28.83	14.78	1.33
2650.0	13.73	36.69	11.64	5.75	4.98	0.76	29.28	14.65	1.42
2700.0	13.44	36.58	11.64	5.31	4.89	0.73	29.32	14.13	1.46
2750.0	13.14	36.54	11.58	4.96	4.86	0.71	28.64	13.98	1.42
2800.0	12.84	36.71	11.57	4.66	4.95	0.68	28.87	13.95	1.45
2850.0	12.54	36.71	11.60	4.37	4.94	0.66	28.38	13.93	1.54
2900.0	12.24	36.75	11.55	4.11	4.96	0.63	28.28	13.56	1.57
2950.0	11.93	36.82	11.59	3.87	4.99	0.61	28.75	13.44	1.56
3000.0	11.62	37.09	11.62	3.68	5.16	0.59	29.68	13.47	1.57

Typical Performance Data

Definitions:

Input Return Loss = -S11 (dB)

Gain(Power Gain) = S21 (dB)

Reverse Isolation = -S12 (dB)

Output Return Loss = -S22 (dB)

TEST CONDITIONS: Vd = 3.00V, Is = 40.13mA @ Temperature = -45°C

FREQ	Gain	Isolation	Input Return Loss	Output Return Loss	Stability		IP-3 Output	1dB Comp. Output	Noise Figure
					K	Measure			
(MHz)	(dB)	(dB)	(dB)	(dB)	K	Measure	(dBm)	(dBm)	(dB)
1200.0	18.57	40.51	16.18	3.81	3.61	0.59	26.26	14.57	0.36
1250.0	18.78	39.90	16.27	4.51	3.62	0.66	26.51	15.11	0.39
1300.0	18.97	39.27	16.14	5.32	3.58	0.72	27.05	15.11	0.40
1350.0	19.09	38.75	15.82	6.28	3.59	0.78	27.41	15.77	0.42
1400.0	19.13	38.32	15.41	7.39	3.63	0.84	27.89	15.51	0.36
1450.0	19.11	38.02	14.98	8.63	3.69	0.89	28.29	15.47	0.38
1500.0	19.05	37.74	14.55	10.11	3.76	0.93	28.23	15.44	0.43
1550.0	18.92	37.61	14.19	11.94	3.89	0.97	28.60	15.94	0.51
1600.0	18.60	37.52	13.98	14.73	4.12	1.00	27.96	15.25	0.49
1650.0	18.37	37.58	13.50	15.42	4.26	1.01	28.57	15.31	0.54
1700.0	18.43	37.09	13.22	17.52	4.04	1.02	28.34	15.19	0.56
1750.0	18.31	36.98	13.02	20.55	4.08	1.03	28.92	15.43	0.54
1800.0	18.11	36.72	13.02	24.18	4.08	1.03	29.29	15.43	0.57
1850.0	17.91	36.71	12.85	24.23	4.17	1.04	28.96	15.67	0.57
1900.0	17.64	36.75	12.76	20.66	4.30	1.03	28.78	15.82	0.59
1950.0	17.29	36.80	12.72	17.35	4.46	1.02	27.78	15.03	0.62
2000.0	16.63	37.41	12.44	15.56	5.10	1.01	27.78	15.26	0.68
2050.0	16.79	36.71	12.17	16.07	4.63	1.02	28.02	15.30	0.67
2100.0	16.74	36.63	12.20	14.17	4.56	1.00	27.51	15.18	0.68
2150.0	16.46	36.55	12.22	12.23	4.57	0.98	27.33	14.83	0.84
2200.0	16.06	36.73	12.05	10.57	4.73	0.95	26.56	14.73	0.78
2250.0	15.34	37.07	11.92	9.44	5.19	0.92	26.13	14.20	0.76
2300.0	15.39	36.44	11.65	10.06	4.87	0.94	26.31	14.19	0.77
2350.0	15.54	36.33	11.75	9.61	4.68	0.93	26.33	14.29	0.77
2400.0	15.35	36.32	11.77	8.75	4.66	0.90	25.80	14.00	0.83
2450.0	15.09	36.44	11.71	7.99	4.73	0.87	25.83	13.96	0.83
2500.0	14.79	36.52	11.70	7.33	4.79	0.84	25.22	13.93	0.88
2550.0	14.53	36.46	11.55	6.79	4.75	0.82	25.58	14.07	0.92
2600.0	14.25	36.61	11.63	6.32	4.85	0.79	25.77	13.91	0.92
2650.0	13.97	36.68	11.57	5.87	4.88	0.77	25.92	13.78	0.99
2700.0	13.69	36.65	11.54	5.42	4.83	0.74	26.09	13.26	1.02
2750.0	13.39	36.76	11.47	5.06	4.89	0.71	25.45	13.16	1.01
2800.0	13.09	37.02	11.46	4.76	5.04	0.69	25.63	13.12	1.06
2850.0	12.80	36.99	11.46	4.44	5.00	0.66	25.32	13.05	1.08
2900.0	12.50	37.22	11.45	4.17	5.11	0.64	25.13	12.66	1.09
2950.0	12.20	37.15	11.53	3.90	5.06	0.61	25.55	12.55	1.10
3000.0	11.91	37.27	11.52	3.66	5.09	0.59	26.55	12.61	1.09

Typical Performance Data

Definitions:

Input Return Loss = -S11 (dB)

Gain(Power Gain) = S21 (dB)

Reverse Isolation = -S12 (dB)

Output Return Loss = -S22 (dB)

TEST CONDITIONS: Vd = 2.70V, Is = 34.82mA @ Temperature = -45°C

FREQ	Gain	Isolation	Input Return Loss	Output Return Loss	Stability		IP-3 Output	1dB Comp. Output	Noise Figure
					K	Measure			
(MHz)	(dB)	(dB)	(dB)	(dB)	K	Measure	(dBm)	(dBm)	(dB)
1200.0	18.29	39.72	14.98	3.89	3.40	0.61	25.06	13.43	0.36
1250.0	18.49	39.11	14.83	4.61	3.41	0.67	25.41	13.98	0.41
1300.0	18.66	38.50	14.57	5.44	3.39	0.74	25.74	14.00	0.41
1350.0	18.78	38.02	14.20	6.43	3.41	0.80	26.15	14.64	0.42
1400.0	18.80	37.59	13.79	7.58	3.44	0.86	26.45	14.45	0.39
1450.0	18.77	37.32	13.43	8.86	3.52	0.91	26.59	14.48	0.37
1500.0	18.70	37.06	13.07	10.39	3.58	0.95	26.29	14.42	0.44
1550.0	18.56	36.94	12.81	12.30	3.71	0.99	26.81	14.98	0.53
1600.0	18.24	36.87	12.63	15.21	3.94	1.02	25.85	14.28	0.51
1650.0	18.00	36.92	12.25	15.94	4.07	1.03	26.26	14.35	0.51
1700.0	18.05	36.49	12.03	18.29	3.89	1.04	25.99	14.23	0.57
1750.0	17.92	36.39	11.89	21.76	3.93	1.05	26.33	14.49	0.65
1800.0	17.72	36.15	11.89	25.76	3.94	1.05	26.45	14.51	0.57
1850.0	17.51	36.15	11.78	24.56	4.04	1.05	26.20	14.73	0.59
1900.0	17.24	36.20	11.73	20.30	4.17	1.04	26.08	14.89	0.62
1950.0	16.89	36.27	11.71	16.93	4.33	1.03	25.17	14.09	0.66
2000.0	16.22	36.89	11.49	15.10	4.95	1.02	25.25	14.33	0.69
2050.0	16.38	36.26	11.26	15.51	4.53	1.03	25.34	14.34	0.73
2100.0	16.33	36.18	11.31	13.76	4.46	1.01	24.93	14.22	0.69
2150.0	16.04	36.13	11.36	11.92	4.49	0.98	24.69	13.88	0.93
2200.0	15.64	36.34	11.21	10.32	4.67	0.95	24.06	13.78	0.79
2250.0	14.92	36.69	11.11	9.22	5.12	0.93	23.72	13.24	0.76
2300.0	14.97	36.13	10.88	9.77	4.83	0.94	23.81	13.23	0.80
2350.0	15.11	36.03	11.01	9.33	4.66	0.93	23.79	13.31	0.82
2400.0	14.91	36.04	11.04	8.51	4.65	0.90	23.30	13.03	0.88
2450.0	14.65	36.18	11.00	7.78	4.73	0.87	23.36	12.96	0.86
2500.0	14.35	36.31	11.03	7.13	4.82	0.84	22.89	12.93	0.91
2550.0	14.09	36.29	10.91	6.61	4.80	0.82	23.22	13.08	0.93
2600.0	13.81	36.48	10.98	6.15	4.91	0.79	23.78	12.91	0.97
2650.0	13.53	36.58	10.96	5.72	4.96	0.77	24.03	12.70	1.03
2700.0	13.25	36.60	10.95	5.28	4.94	0.73	24.23	12.21	1.05
2750.0	12.94	36.74	10.91	4.93	5.02	0.71	23.68	12.07	1.04
2800.0	12.64	37.05	10.90	4.63	5.19	0.69	23.85	12.06	1.07
2850.0	12.35	37.08	10.92	4.32	5.19	0.66	23.60	11.95	1.11
2900.0	12.05	37.35	10.93	4.06	5.33	0.63	23.36	11.49	1.12
2950.0	11.76	37.33	11.02	3.79	5.29	0.61	23.84	11.38	1.16
3000.0	11.47	37.53	11.02	3.56	5.38	0.58	24.86	11.47	1.11

Typical Performance Data

Definitions:

Input Return Loss = -S11 (dB)

Gain(Power Gain) = S21 (dB)

Reverse Isolation = -S12 (dB)

Output Return Loss = -S22 (dB)

TEST CONDITIONS: Vd = 3.30V, Is = 45.57mA @ Temperature = -45°C

FREQ	Gain	Isolation	Input Return Loss	Output Return Loss	Stability		IP-3 Output	1dB Comp. Output	Noise Figure
					K	Measure			
(MHz)	(dB)	(dB)	(dB)	(dB)	K	Measure	(dBm)	(dBm)	(dB)
1200.0	18.79	41.18	16.95	3.72	3.77	0.58	27.41	15.62	0.35
1250.0	19.01	40.58	17.36	4.41	3.79	0.64	27.71	16.18	0.40
1300.0	19.21	39.93	17.50	5.19	3.75	0.70	28.23	16.12	0.39
1350.0	19.35	39.39	17.32	6.12	3.75	0.77	28.59	16.75	0.40
1400.0	19.40	38.91	16.94	7.20	3.77	0.82	29.12	16.47	0.38
1450.0	19.38	38.64	16.48	8.40	3.85	0.87	29.38	16.42	0.39
1500.0	19.33	38.33	15.99	9.82	3.91	0.91	29.38	16.38	0.42
1550.0	19.22	38.19	15.56	11.57	4.04	0.95	29.60	16.84	0.53
1600.0	18.90	38.08	15.29	14.22	4.27	0.98	29.37	16.15	0.49
1650.0	18.67	38.12	14.72	14.88	4.41	0.99	30.23	16.18	0.52
1700.0	18.75	37.64	14.39	16.74	4.18	1.01	29.85	16.06	0.55
1750.0	18.63	37.50	14.10	19.43	4.21	1.02	30.51	16.26	0.57
1800.0	18.45	37.23	14.12	22.70	4.20	1.02	31.04	16.27	0.55
1850.0	18.25	37.20	13.88	23.64	4.29	1.02	30.67	16.54	0.57
1900.0	17.98	37.22	13.76	20.97	4.41	1.02	30.39	16.67	0.60
1950.0	17.64	37.26	13.68	17.81	4.57	1.01	30.05	15.86	0.64
2000.0	16.97	37.82	13.36	16.12	5.21	1.01	29.80	16.14	0.67
2050.0	17.13	37.12	13.03	16.68	4.72	1.01	30.01	16.11	0.70
2100.0	17.10	37.03	13.05	14.63	4.64	1.00	29.72	16.02	0.66
2150.0	16.82	36.95	13.05	12.58	4.65	0.97	29.66	15.66	0.87
2200.0	16.43	37.07	12.83	10.84	4.79	0.95	28.86	15.58	0.79
2250.0	15.70	37.41	12.68	9.69	5.26	0.92	28.51	15.05	0.73
2300.0	15.75	36.75	12.36	10.39	4.92	0.94	28.81	15.04	0.77
2350.0	15.92	36.62	12.45	9.93	4.72	0.93	28.95	15.14	0.75
2400.0	15.73	36.57	12.44	9.02	4.67	0.90	28.40	14.85	0.84
2450.0	15.48	36.66	12.35	8.23	4.72	0.88	28.45	14.82	0.83
2500.0	15.19	36.73	12.32	7.54	4.77	0.85	27.72	14.82	0.86
2550.0	14.92	36.64	12.13	6.98	4.72	0.82	28.07	14.96	0.88
2600.0	14.65	36.78	12.17	6.50	4.81	0.80	28.02	14.80	0.91
2650.0	14.38	36.81	12.11	6.04	4.83	0.77	27.95	14.68	0.97
2700.0	14.10	36.75	12.05	5.57	4.76	0.74	28.16	14.18	1.03
2750.0	13.80	36.83	11.96	5.20	4.80	0.72	27.43	14.06	0.97
2800.0	13.50	37.04	11.91	4.89	4.92	0.70	27.62	14.04	1.03
2850.0	13.20	36.99	11.89	4.56	4.87	0.67	27.21	13.97	1.03
2900.0	12.91	37.19	11.86	4.28	4.97	0.65	27.12	13.58	1.06
2950.0	12.61	37.08	11.93	4.01	4.89	0.62	27.50	13.50	1.07
3000.0	12.32	37.16	11.93	3.76	4.91	0.60	28.42	13.60	1.06

Typical Performance Data

Definitions:

Input Return Loss = -S11 (dB)

Gain(Power Gain) = S21 (dB)

Reverse Isolation = -S12 (dB)

Output Return Loss = -S22 (dB)

TEST CONDITIONS: Vd = 3.00V, Is = 42.18mA @ Temperature = +85°C

FREQ	Gain	Isolation	Input Return Loss	Output Return Loss	Stability		IP-3 Output	1dB Comp. Output	Noise Figure
					K	Measure			
(MHz)	(dB)	(dB)	(dB)	(dB)	K	Measure	(dBm)	(dBm)	(dB)
1200.0	17.72	40.78	14.65	4.11	4.20	0.63	27.58	14.82	0.70
1250.0	17.92	40.18	14.19	4.79	4.16	0.69	28.28	15.31	0.77
1300.0	18.12	39.56	13.75	5.64	4.10	0.76	28.87	15.27	0.76
1350.0	18.23	39.09	13.33	6.70	4.12	0.83	29.24	15.90	0.81
1400.0	18.27	38.66	12.95	7.92	4.15	0.88	29.84	15.61	0.79
1450.0	18.24	38.41	12.65	9.32	4.25	0.93	30.13	15.57	0.83
1500.0	18.16	38.14	12.38	10.99	4.32	0.97	30.01	15.55	0.86
1550.0	18.03	37.97	12.14	13.09	4.43	1.01	30.29	15.95	0.96
1600.0	17.75	37.91	12.05	16.27	4.68	1.03	29.97	15.27	1.00
1650.0	17.42	38.11	11.70	17.54	4.98	1.05	30.53	15.36	1.01
1700.0	17.50	37.58	11.52	19.72	4.66	1.05	30.23	15.18	1.07
1750.0	17.37	37.48	11.36	23.06	4.70	1.06	31.15	15.36	1.09
1800.0	17.17	37.36	11.32	24.77	4.76	1.06	31.56	15.42	1.07
1850.0	16.95	37.22	11.20	21.91	4.79	1.06	31.10	15.67	1.09
1900.0	16.67	37.20	11.12	18.55	4.90	1.05	30.56	15.80	1.16
1950.0	16.33	37.31	11.07	15.85	5.10	1.04	29.20	15.00	1.21
2000.0	15.74	37.75	10.96	13.96	5.65	1.02	29.56	15.39	1.25
2050.0	15.57	37.48	10.66	14.40	5.58	1.03	29.24	15.17	1.30
2100.0	15.72	37.05	10.64	13.49	5.19	1.02	28.84	15.03	1.32
2150.0	15.48	36.93	10.72	11.69	5.15	0.99	28.63	14.72	1.49
2200.0	15.08	37.07	10.63	10.23	5.33	0.96	27.62	14.58	1.44
2250.0	14.51	37.41	10.57	9.36	5.77	0.94	27.59	14.21	1.42
2300.0	14.45	36.82	10.43	9.42	5.43	0.94	27.76	14.23	1.52
2350.0	14.50	36.69	10.48	8.97	5.26	0.93	27.58	14.20	1.51
2400.0	14.32	36.68	10.57	8.23	5.24	0.90	27.00	13.91	1.59
2450.0	14.06	36.77	10.58	7.56	5.30	0.87	26.97	13.92	1.60
2500.0	13.77	36.75	10.63	6.94	5.30	0.84	26.88	13.84	1.64
2550.0	13.49	36.73	10.53	6.43	5.28	0.82	27.92	14.04	1.71
2600.0	13.18	36.81	10.64	5.98	5.37	0.79	28.03	13.91	1.74
2650.0	12.91	36.73	10.64	5.58	5.31	0.76	28.54	13.78	1.83
2700.0	12.61	36.65	10.64	5.16	5.24	0.73	28.65	13.20	1.91
2750.0	12.31	36.65	10.65	4.84	5.24	0.71	27.87	13.08	1.89
2800.0	12.00	36.86	10.67	4.55	5.37	0.68	28.05	13.01	1.94
2850.0	11.70	36.69	10.72	4.26	5.26	0.66	27.77	12.97	2.00
2900.0	11.40	36.80	10.69	4.02	5.31	0.64	27.80	12.68	2.04
2950.0	11.09	36.63	10.74	3.77	5.20	0.61	28.16	12.60	2.08
3000.0	10.79	36.54	10.75	3.56	5.12	0.59	29.08	12.50	2.05

Typical Performance Data

Definitions:

Input Return Loss = -S11 (dB)

Gain(Power Gain) = S21 (dB)

Reverse Isolation = -S12 (dB)

Output Return Loss = -S22 (dB)

TEST CONDITIONS: Vd = 2.70V, Is = 37.21mA @ Temperature = +85°C

FREQ	Gain	Isolation	Input Return Loss	Output Return Loss	Stability		IP-3 Output	1dB Comp. Output	Noise Figure
					K	Measure			
(MHz)	(dB)	(dB)	(dB)	(dB)	K	Measure	(dBm)	(dBm)	(dB)
1200.0	17.49	40.06	13.47	4.19	3.97	0.65	26.44	13.69	0.71
1250.0	17.67	39.47	13.02	4.90	3.93	0.71	27.05	14.20	0.77
1300.0	17.86	38.88	12.62	5.78	3.89	0.78	27.33	14.19	0.79
1350.0	17.97	38.40	12.23	6.87	3.90	0.85	27.74	14.83	0.81
1400.0	17.99	38.02	11.90	8.13	3.95	0.90	28.02	14.59	0.82
1450.0	17.96	37.76	11.66	9.58	4.04	0.95	28.17	14.58	0.82
1500.0	17.88	37.51	11.45	11.33	4.12	0.99	27.81	14.58	0.87
1550.0	17.73	37.35	11.25	13.54	4.23	1.03	28.32	15.04	1.00
1600.0	17.44	37.33	11.17	16.95	4.48	1.05	27.44	14.38	1.02
1650.0	17.11	37.53	10.89	18.28	4.76	1.06	27.85	14.44	1.03
1700.0	17.18	37.04	10.73	20.87	4.49	1.07	27.43	14.29	1.05
1750.0	17.05	36.95	10.61	24.72	4.54	1.08	28.12	14.53	1.14
1800.0	16.84	36.86	10.58	25.49	4.61	1.08	28.20	14.55	1.11
1850.0	16.61	36.73	10.49	21.57	4.64	1.07	27.96	14.79	1.13
1900.0	16.33	36.73	10.42	18.08	4.76	1.06	27.75	14.96	1.20
1950.0	15.99	36.86	10.39	15.41	4.96	1.04	26.55	14.14	1.26
2000.0	15.40	37.30	10.30	13.54	5.49	1.03	26.99	14.54	1.32
2050.0	15.22	37.08	10.04	13.87	5.46	1.04	26.57	14.32	1.33
2100.0	15.36	36.68	10.03	13.04	5.09	1.03	26.28	14.19	1.32
2150.0	15.13	36.57	10.11	11.34	5.06	1.00	26.04	13.87	1.57
2200.0	14.71	36.75	10.04	9.95	5.26	0.97	25.31	13.72	1.50
2250.0	14.15	37.09	9.99	9.10	5.68	0.94	25.20	13.33	1.50
2300.0	14.09	36.56	9.88	9.12	5.39	0.95	25.27	13.36	1.53
2350.0	14.13	36.44	9.95	8.68	5.22	0.93	25.14	13.33	1.55
2400.0	13.94	36.46	10.04	7.97	5.23	0.90	24.63	13.05	1.64
2450.0	13.67	36.59	10.05	7.33	5.31	0.87	24.92	13.03	1.64
2500.0	13.38	36.59	10.11	6.73	5.32	0.84	25.10	12.93	1.70
2550.0	13.10	36.60	10.03	6.24	5.32	0.81	25.96	13.13	1.77
2600.0	12.79	36.71	10.13	5.81	5.42	0.79	26.26	13.01	1.79
2650.0	12.51	36.68	10.13	5.42	5.39	0.76	26.74	12.86	1.90
2700.0	12.22	36.63	10.15	5.02	5.33	0.73	26.80	12.30	1.96
2750.0	11.91	36.64	10.17	4.70	5.35	0.70	26.31	12.17	1.95
2800.0	11.60	36.90	10.19	4.42	5.51	0.68	26.44	12.11	1.97
2850.0	11.30	36.75	10.24	4.14	5.40	0.65	26.13	12.04	2.08
2900.0	10.99	36.89	10.22	3.90	5.48	0.63	26.16	11.75	2.10
2950.0	10.68	36.77	10.27	3.66	5.38	0.61	26.51	11.62	2.14
3000.0	10.38	36.70	10.28	3.46	5.32	0.58	27.39	11.57	2.14

Typical Performance Data

Definitions:

Input Return Loss = -S11 (dB)

Gain(Power Gain) = S21 (dB)

Reverse Isolation = -S12 (dB)

Output Return Loss = -S22 (dB)

TEST CONDITIONS: Vd = 3.30V, Is = 47.17mA @ Temperature = +85°C

FREQ	Gain	Isolation	Input Return Loss	Output Return Loss	Stability		IP-3 Output	1dB Comp. Output	Noise Figure
					K	Measure			
(MHz)	(dB)	(dB)	(dB)	(dB)	K	Measure	(dBm)	(dBm)	(dB)
1200.0	17.90	41.39	15.73	4.03	4.41	0.62	28.04	15.76	0.72
1250.0	18.11	40.75	15.26	4.70	4.35	0.68	28.84	16.19	0.75
1300.0	18.31	40.11	14.78	5.53	4.27	0.75	29.58	16.13	0.76
1350.0	18.44	39.63	14.30	6.56	4.29	0.81	29.75	16.76	0.81
1400.0	18.48	39.19	13.89	7.74	4.32	0.87	30.41	16.45	0.79
1450.0	18.46	38.93	13.53	9.09	4.41	0.92	31.18	16.36	0.78
1500.0	18.39	38.63	13.25	10.70	4.47	0.96	31.44	16.36	0.86
1550.0	18.27	38.44	12.96	12.70	4.58	0.99	31.43	16.74	0.97
1600.0	17.99	38.38	12.82	15.71	4.84	1.02	32.60	16.05	0.97
1650.0	17.66	38.57	12.44	16.89	5.14	1.03	32.76	16.16	0.99
1700.0	17.74	38.02	12.21	18.81	4.81	1.04	33.05	15.98	1.00
1750.0	17.63	37.90	12.04	21.80	4.84	1.05	34.06	16.16	1.07
1800.0	17.43	37.79	11.97	23.96	4.90	1.05	35.22	16.19	1.07
1850.0	17.22	37.62	11.82	22.11	4.92	1.05	34.71	16.45	1.09
1900.0	16.95	37.57	11.71	18.98	5.01	1.04	33.89	16.59	1.15
1950.0	16.61	37.67	11.65	16.26	5.21	1.03	33.58	15.76	1.21
2000.0	16.02	38.11	11.52	14.36	5.78	1.02	32.97	16.17	1.27
2050.0	15.84	37.79	11.20	14.88	5.69	1.03	32.81	15.96	1.30
2100.0	16.00	37.32	11.13	13.93	5.25	1.02	32.95	15.79	1.28
2150.0	15.78	37.19	11.21	12.02	5.20	0.99	32.94	15.51	1.54
2200.0	15.37	37.30	11.12	10.51	5.37	0.96	31.20	15.35	1.42
2250.0	14.80	37.61	11.04	9.62	5.80	0.94	31.26	14.99	1.45
2300.0	14.74	37.00	10.88	9.71	5.45	0.95	31.64	15.02	1.46
2350.0	14.81	36.86	10.91	9.25	5.26	0.93	31.70	15.00	1.48
2400.0	14.63	36.82	11.00	8.48	5.23	0.90	30.70	14.72	1.58
2450.0	14.38	36.88	11.00	7.78	5.27	0.88	30.51	14.72	1.58
2500.0	14.09	36.82	11.04	7.13	5.24	0.85	29.82	14.63	1.60
2550.0	13.81	36.78	10.93	6.61	5.22	0.82	30.60	14.83	1.70
2600.0	13.50	36.84	11.04	6.15	5.29	0.79	30.70	14.71	1.72
2650.0	13.24	36.72	11.01	5.73	5.21	0.77	31.15	14.59	1.82
2700.0	12.95	36.62	11.01	5.30	5.12	0.74	31.17	14.02	1.87
2750.0	12.65	36.60	11.02	4.97	5.12	0.71	30.33	13.91	1.84
2800.0	12.34	36.77	11.04	4.67	5.23	0.69	30.54	13.85	1.87
2850.0	12.04	36.59	11.07	4.37	5.10	0.66	29.88	13.79	1.95
2900.0	11.74	36.62	11.04	4.12	5.11	0.64	29.81	13.54	2.02
2950.0	11.43	36.45	11.08	3.86	5.00	0.62	30.24	13.41	2.03
3000.0	11.13	36.33	11.08	3.64	4.92	0.60	31.00	13.37	2.01

Typical Performance Curves

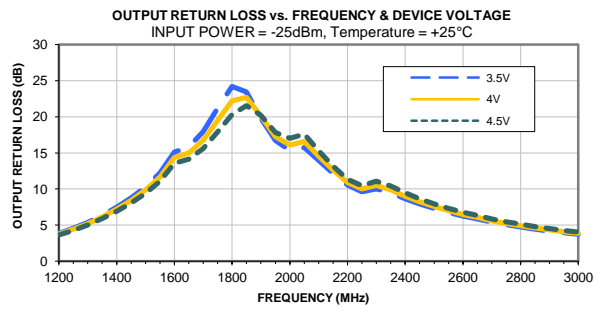
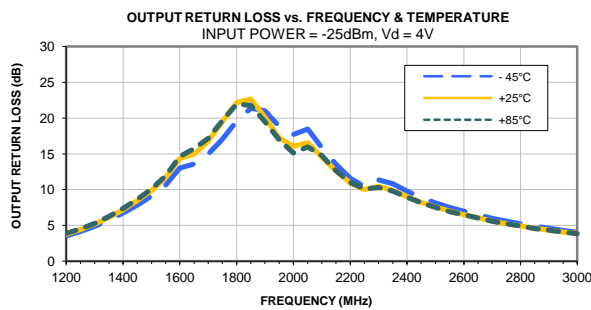
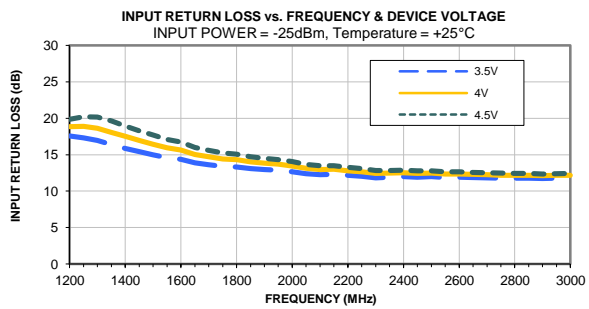
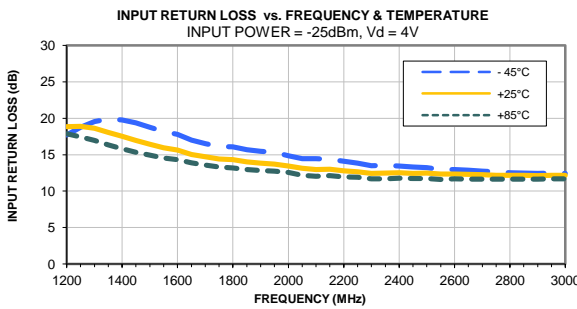
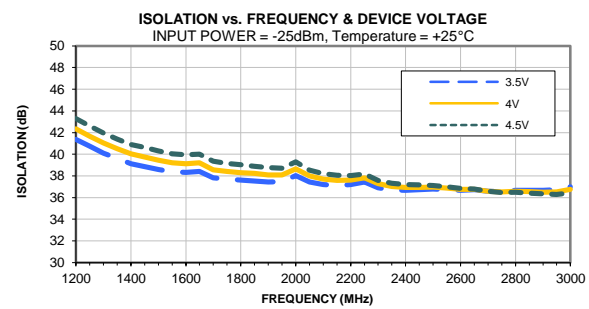
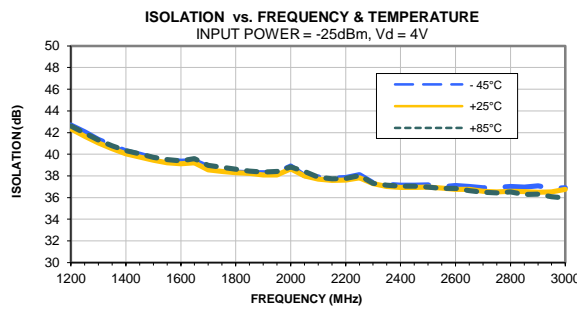
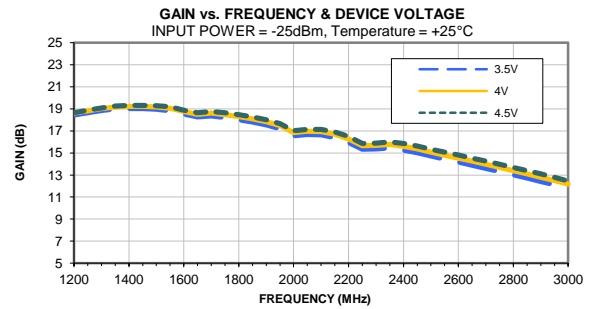
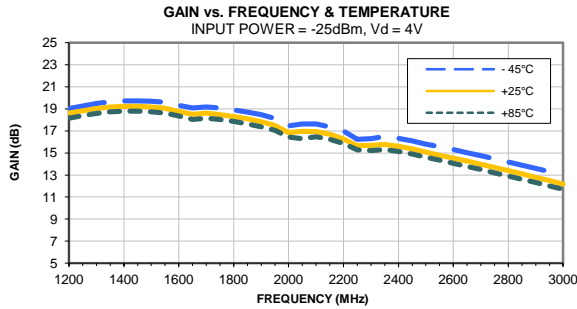

Typical Performance Curves

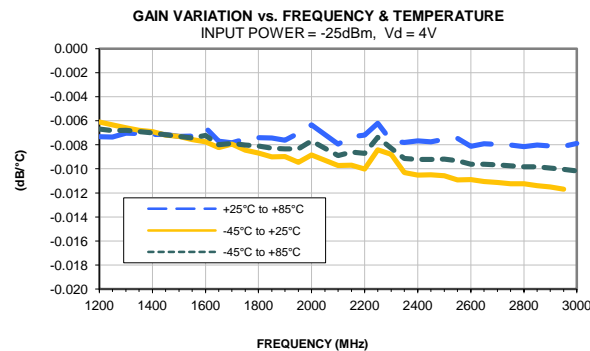
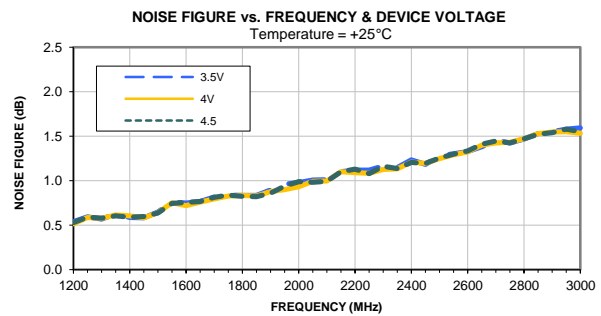
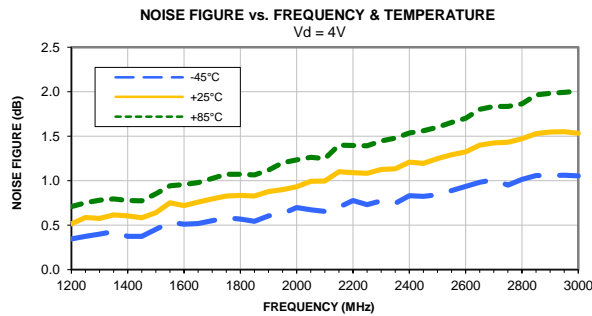
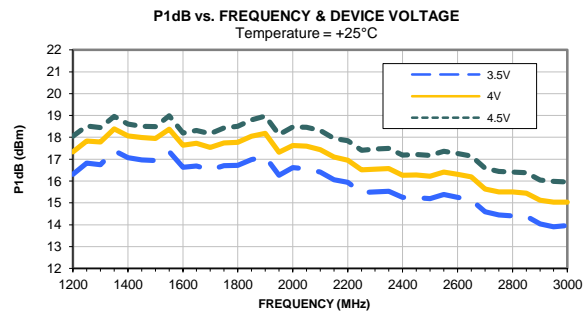
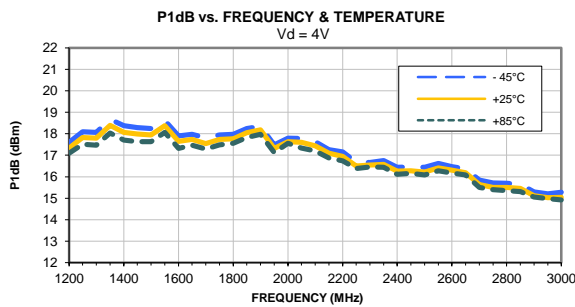
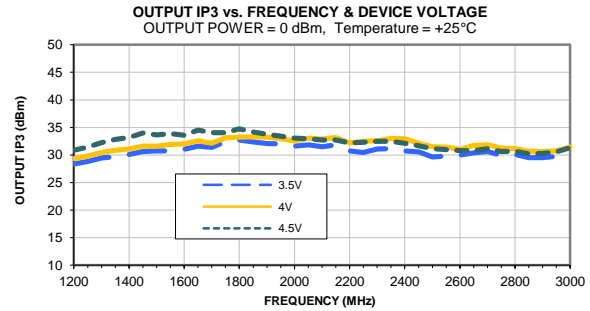
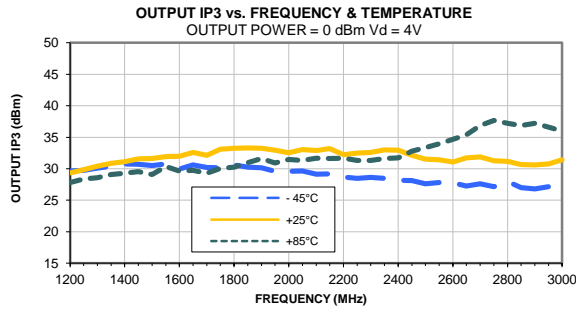

Typical Performance Curves

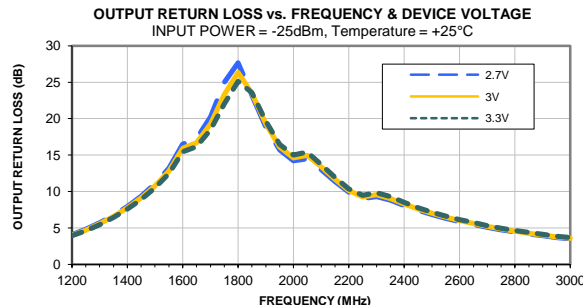
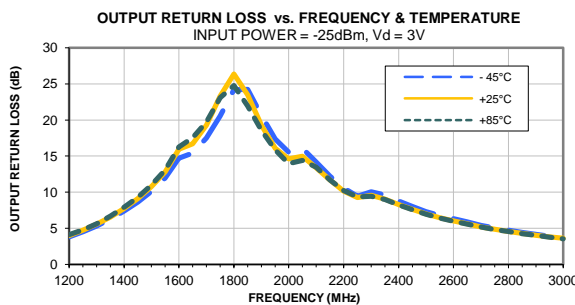
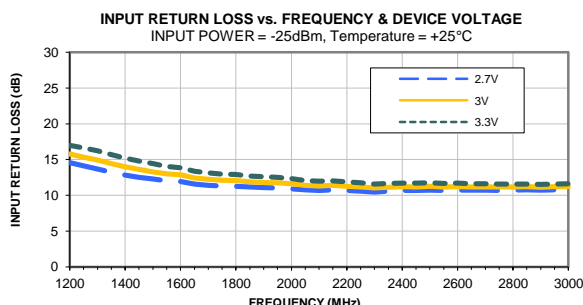
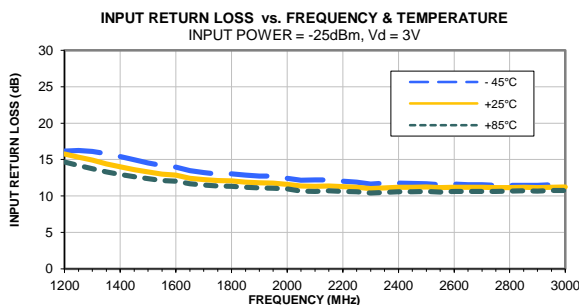
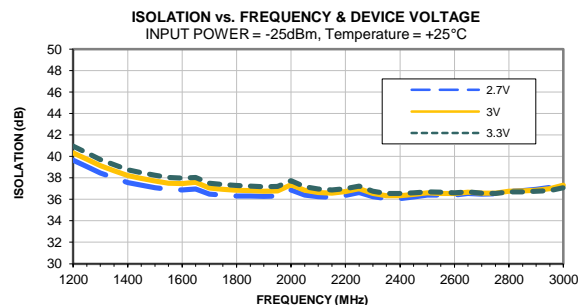
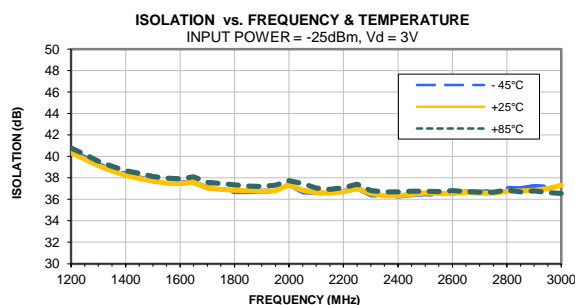
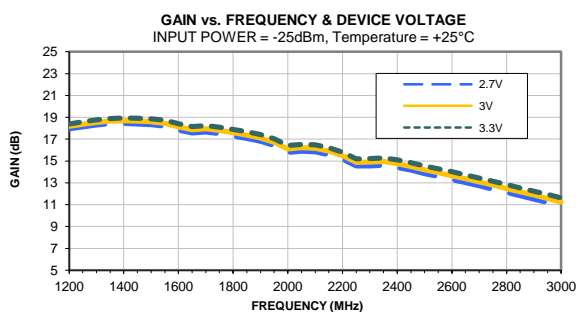
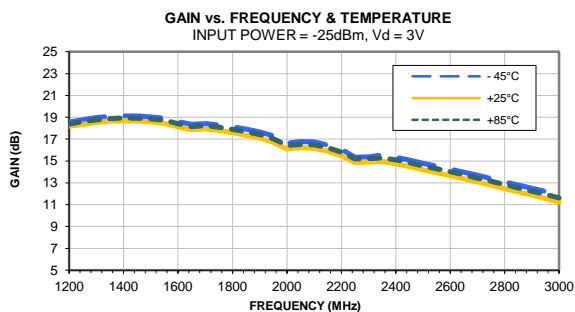

Typical Performance Curves

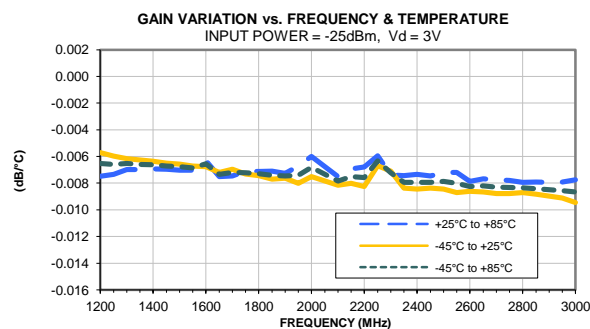
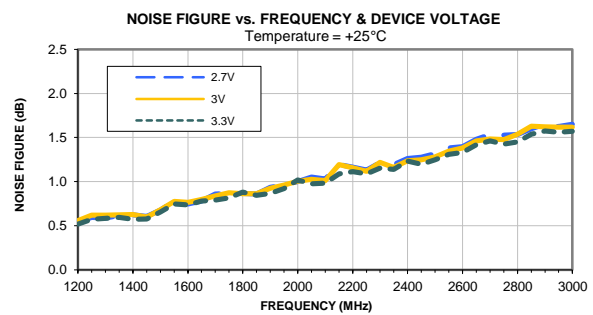
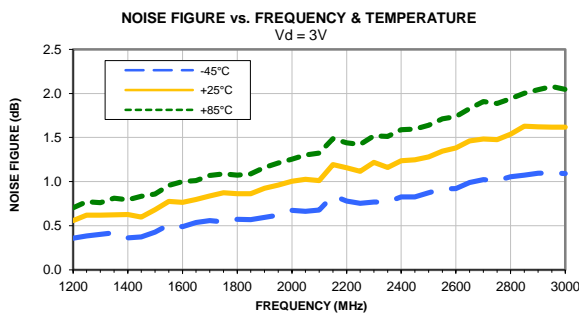
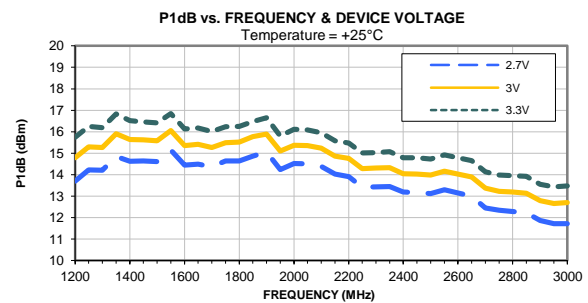
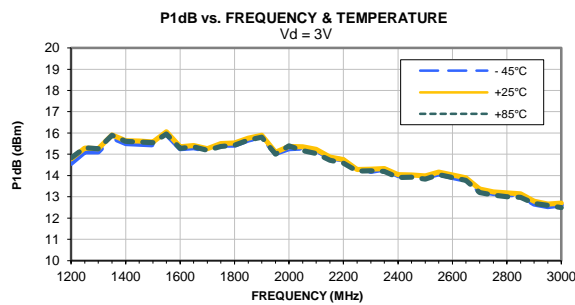
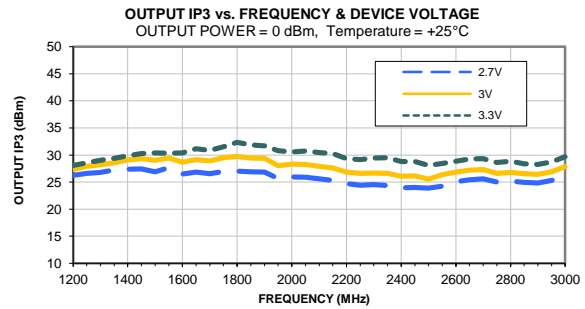
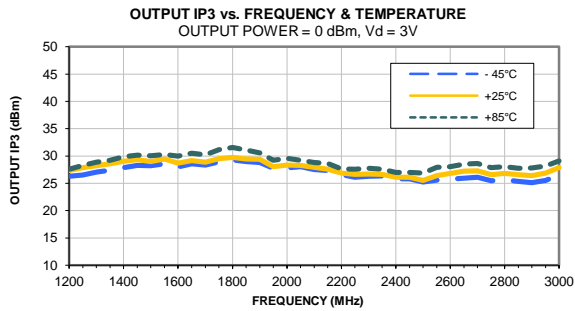

Outline Dimensions

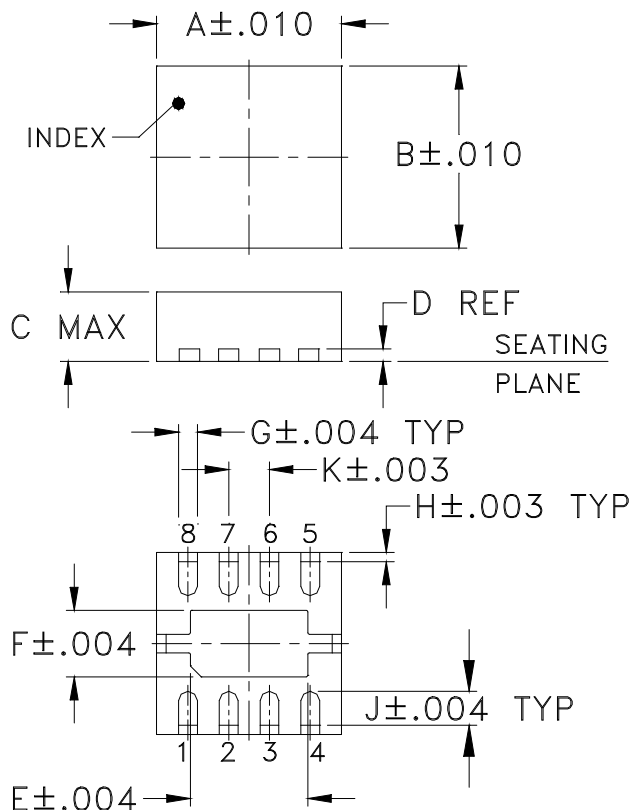

PCB Land Pattern

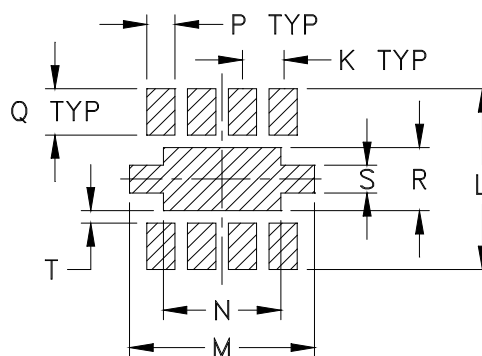

Suggested Layout,
Tolerance to be within $\pm .002$

CASE #	A	B	C	D	E	F	G	H	J	K	L	M	N
DL1721	.118 (3.00)	.118 (3.00)	.045 (1.14)	.008 (0.20)	.075 (1.91)	.043 (1.09)	.012 (0.30)	.006 (0.15)	.022 (0.56)	.026 (0.66)	.117 (2.97)	.118 (3.00)	.075 (1.91)

CASE #	P	Q	R	S	T	WT. GRAM
DL1721	.018 (0.46)	.030 (0.76)	.041 (1.04)	.018 (0.46)	.008 (0.20)	.02

Dimensions are in inches (mm). Tolerances: 3Pl. $\pm .004$, unless otherwise specified.

Notes:

1. Case material: LTCC.
2. Termination finish: Nickel-Palladium-Gold plating.



P.O. Box 350166, Brooklyn, New York 11235-0003 (718) 934-4500 Fax (718) 332-4661 For detailed performance specs & shopping online see Mini-Circuits web site



The Design Engineers Search Engine Provides ACTUAL Data Instantly From MINI-CIRCUITS At: www.minicircuits.com

RF/IF MICROWAVE COMPONENTS

Tape & Reel Packaging TR-F66-1

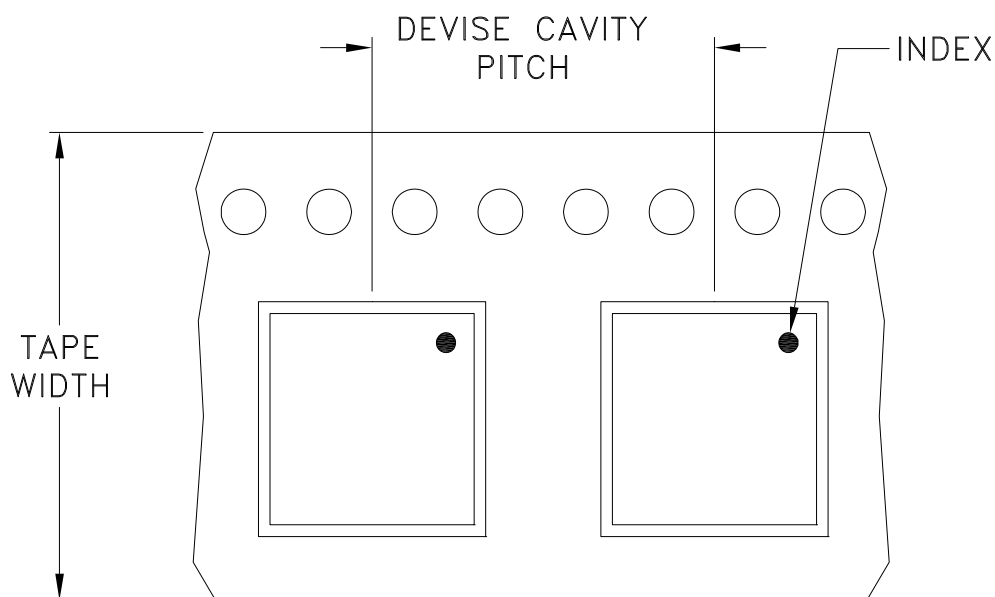

Tape Width, mm	Device Cavity Pitch, mm	Reel Size, inches	Devices per Reel see note	
8	4	7	Small quantity standard	20
				50
				100
				200
				500
		7	Standard	1000, 2000

Note: Please consult individual model data sheet to determine device per reel availability.

Mini-Circuits carrier tape materials provide protection from ESD (Electro-Static Discharge) during handling and transportation. Tapes are static dissipative and comply with industry standards EIA-481/EIA-541.

Go to: www.minicircuits.com/pages/pdfs/tape.pdf



INTERNET <http://www.minicircuits.com>

P.O. Box 350166, Brooklyn, New York 11235-0003 (718) 934-4500 Fax (718) 332-4661

Distribution Centers NORTH AMERICA 800-654-7949 • 417-335-5935 • Fax 417-335-5945 • EUROPE 44-1252-832600 • Fax 44-1252-837010

Mini-Circuits ISO 9001 & ISO 14001 Certified

THIRD ANGLE PROJECTION

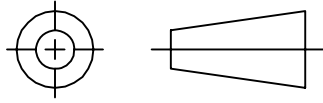

REVISIONS

REV	ECN No.	DESCRIPTION	DATE	DR	AUTH
OR	M144210	NEW RELEASE	11/22/13	AV	DJ

SUGGESTED MOUNTING CONFIGURATION FOR DG1721 CASE STYLE, "08AM12" PIN CODE

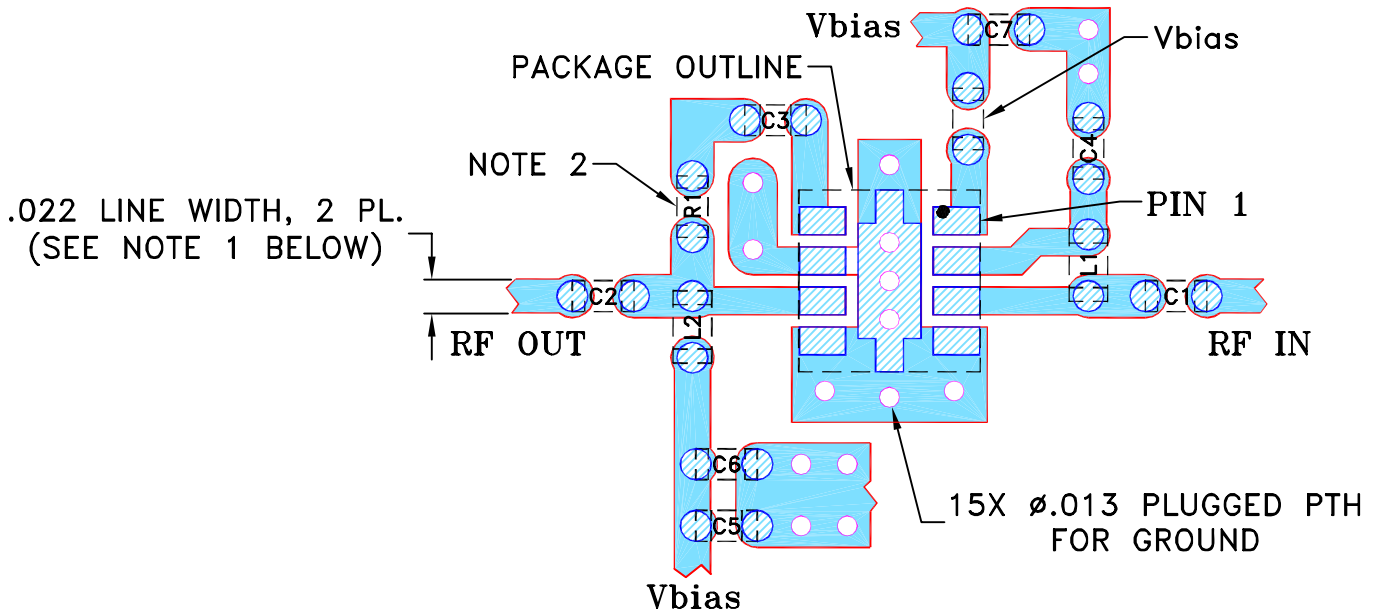

- NOTES: 1. TRACE WIDTH IS SHOWN FOR ROGERS R04350B WITH DIELECTRIC THICKNESS .010" ± .001"; COPPER: 1/2 OZ. EACH SIDE. FOR OTHER MATERIALS TRACE WIDTH MAY NEED TO BE MODIFIED.
2. 0402 SIZE CHIP FOOT PRINTS SHOWN FOR REFERENCE, FOR COMPONENT VALUE REFER TO TB-759+.
3. BOTTOM SIDE OF THE PCB IS CONTINUOUS GROUND PLANE.



DENOTES PCB COPPER LAYOUT WITH SMOBC (SOLDER MASK OVER BARE COPPER)



DENOTES COPPER LAND PATTERN FREE OF SOLDER MASK

UNLESS OTHERWISE SPECIFIED	INITIALS	DATE
DIMENSIONS ARE IN INCHES	DRAWN AV	11/21/13
TOLERANCES ON:	CHECKED IL	11/21/13
2 PL DECIMALS ±	APPROVED DJ	11/22/13
3 PL DECIMALS ± .005		
ANGLES ±		
FRACTIONS ±		



Mini-Circuits®

13 Neptune Avenue
Brooklyn NY 11235

PL, 08AM12, DG1721, TB-759+

Mini-Circuits®
THIS DOCUMENT AND ITS CONTENTS ARE THE PROPERTY OF MINI-CIRCUITS. EXCEPT FOR USE EXPRESSLY GRANTED, IN WRITING, TO ITS VENDORS, VENDEE AND THE UNITED STATES GOVERNMENT, MINI-CIRCUITS RESERVES ALL PROPRIETARY DESIGN, USE, MANUFACTURING AND REPRODUCTION RIGHTS THERETO. THESE CONTENTS SHALL NOT BE USED, DUPLICATED OR DISCLOSED TO ANY OUTSIDE PARTY, IN WHOLE OR IN PART, WITHOUT WRITTEN PERMISSION OF MINI-CIRCUITS.

SIZE	CODE IDENT	DRAWING NO:	REV:
A	15542	98-PL-406	OR

FILE:	SCALE:	SHEET:
98PL406	8:1	1 OF 1

Evaluation Board and Circuit

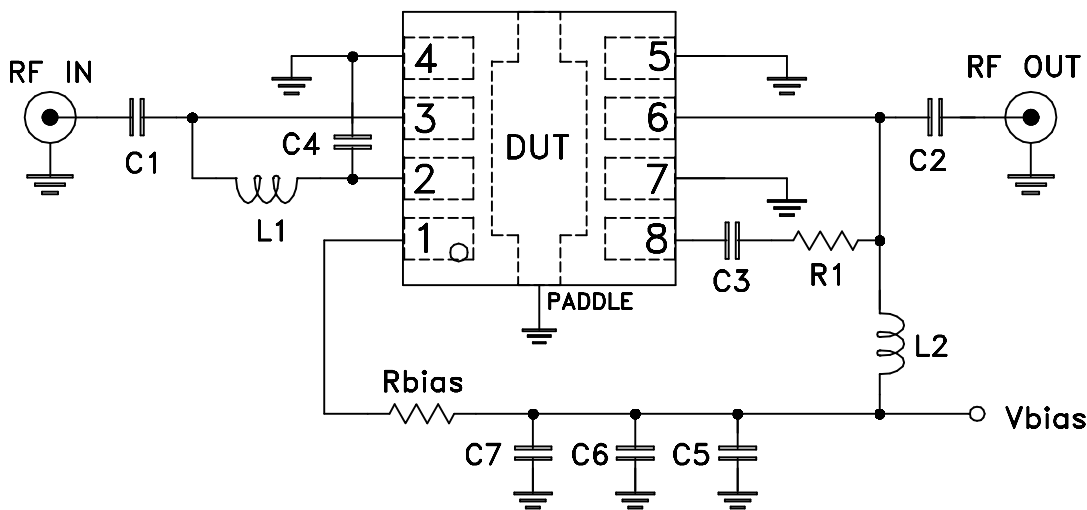
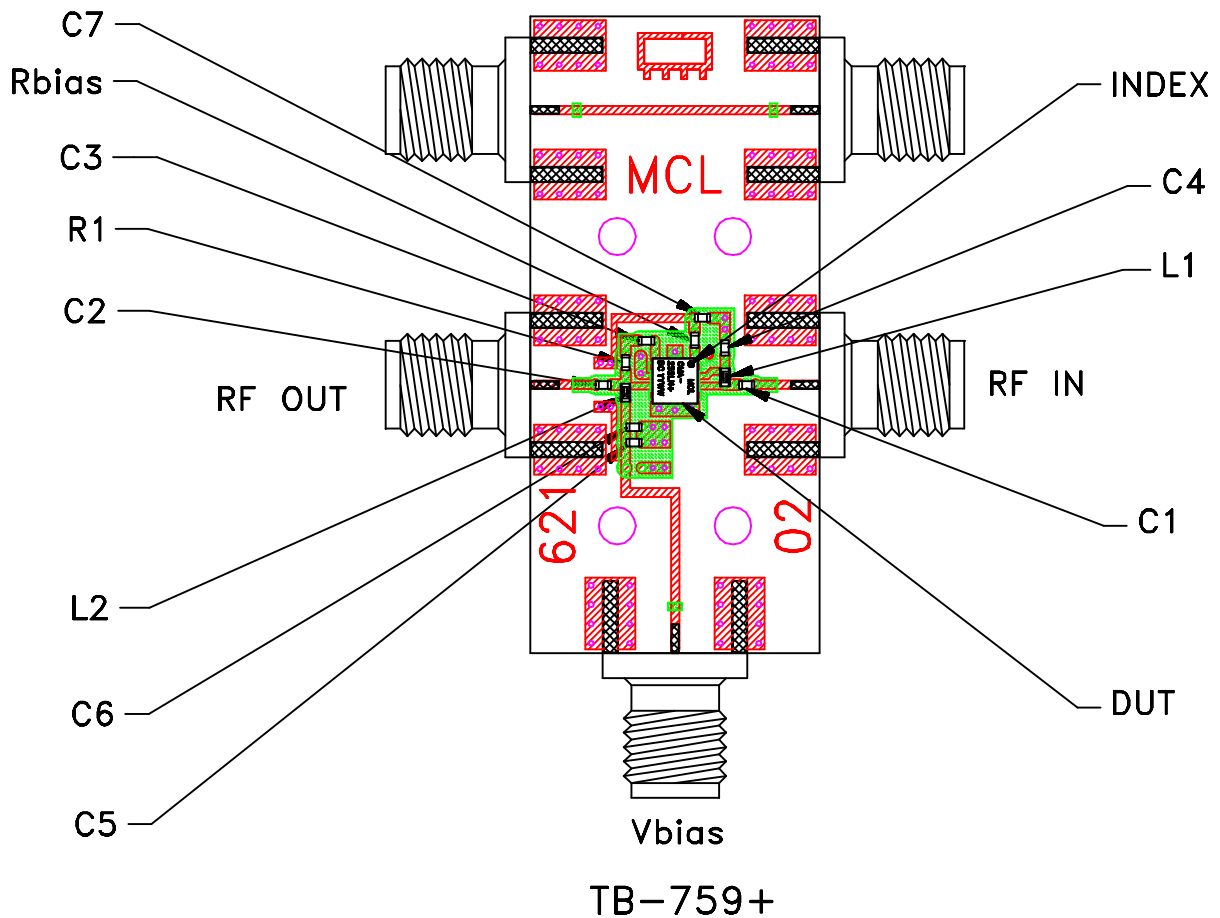

Schematic Diagram

ITEM	DESCRIPTION
C1	CAP, 27pF
C2	CAP, 2.7pF
C3	CAP, 1.2pF
C4	CAP, 220pF
C5	CAP, 7pF
C6, C7	CAP, 0.1uF
R1	RES, 825 Ohm
Rbias	RES, 619 Ohm
L1	IND, 6.8nH
L2	IND, 2.2nH
DUT	CMA-252LN+

NOTES:

1. SMA Female connectors.
2. PCB material: Rogers R04350 or equivalent, dielectric constant=3.5, dielectric thickness=.010 inch.

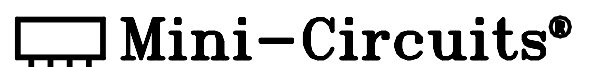



All Mini-Circuits products are manufactured under exacting quality assurance and control standards, and are capable of meeting published specifications after being subjected to any or all of the following physical and environmental test.

Specification	Test/Inspection Condition	Reference/Spec
Operating Temperature	-55° to 105°C	Individual Model Data Sheet
Storage Temperature	-65° to 125° C	Individual Model Data Sheet
Thermal Shock (device level)	-55° to 125°C, 100 cycles	MIL-STD-202, Method 107
Thermal Shock (board level)	-55° to 125°C, 1000 cycles	MIL-STD-202, Method 107
Constant Acceleration	Y1 plane only, 30 Kg	MIL-STD-883, Method 2001, Cond. E
Vibration	10-2000MHz sine, 20g, 3 axis	MIL-STD-202, Method 204, Cond. D
Mechanical Shock	Y1 plane, 5 pulses, .5ms, 1.5 Kg	MIL-STD-202, Method 213, Cond. A
PIND	20G's @130 Hz	MIL-STD-750, Method 2052.2
Resistance to Soldering Heat	3X Reflow, Peak Temperature 260°C, electrical End points	JESD22-B102
Resistance to Solvent	15 pieces, 5 pieces each solvent, marking permanency	MIL-STD-202, Method 215
Moisture Sensitivity Level	Hermetic device, MSL-1 by construction	JESD22-A113, MSL1/260
Hermeticity	Fine Leak, Gross Leak	MIL-STD-202, Method 112, Cond. C&D



All Mini-Circuits products are manufactured under exacting quality assurance and control standards, and are capable of meeting published specifications after being subjected to any or all of the following physical and environmental test.

Specification	Test/Inspection Condition	Reference/Spec
Autoclave	15 psig, 100% RH, 121°C, 96 hours	JEDEC-STD-22-B, Method A102