

Surface Mount Bandpass Filter

CBP-840C+

50Ω 790 to 890 MHz

The Big Deal

- Excellent Rejection
- Low passband Insertion Loss
- Miniature shielded package

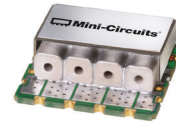

Generic photo used for illustration purposes only
CASE STYLE: MP1766

Product Overview

CBP-840C+ is a ceramic-coaxial-resonator based bandpass filter in a shielded package fabricated using SMT technology. This filter offers outstanding close in rejection, low insertion loss and high power handling for use in aviation, mobile radio, broadband and fixed wireless.

Key Features

Feature	Advantages
High Selectivity	The CBP-840C+ filter incorporates High-Q ceramic resonators that enables sharp rejection near passband.
Low Passband VSWR	This filter maintains typical VSWR over a narrow passband frequency range making this filter easier to integrate into receiver and transmitter RF chains with less concerns for in band frequency ripple.
Rugged construction	The CBP-840C+ has been qualified over wide range of thermal, mechanical and environmental conditions including withstanding the stress of extensive solder reflow cycles.

Notes

- A. Performance and quality attributes and conditions not expressly stated in this specification document are intended to be excluded and do not form a part of this specification document.
B. Electrical specifications and performance data contained in this specification document are based on Mini-Circuit's applicable established test performance criteria and measurement instructions.
C. The parts covered by this specification document are subject to Mini-Circuits standard limited warranty and terms and conditions (collectively, "Standard Terms"); Purchasers of this part are entitled to the rights and benefits contained therein. For a full statement of the Standard Terms and the exclusive rights and remedies thereunder, please visit Mini-Circuits' website at www.minicircuits.com/MCLStore/terms.jsp



Surface Mount Bandpass Filter

CBP-840C+

50Ω 790 to 890 MHz



Generic photo used for illustration purposes only
CASE STYLE: MP1766

Features

- Low Insertion loss
- High selectivity
- Miniature shielded package

Applications

- Traffic collision avoidance system (TCAS)
- Aeronautical radio navigation
- Fixed satellite
- Radio astronomy
- Radar and navigation system

Functional Schematic

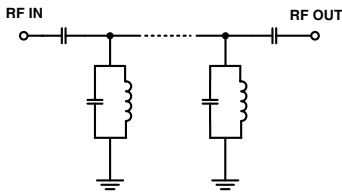

Typical Frequency Response

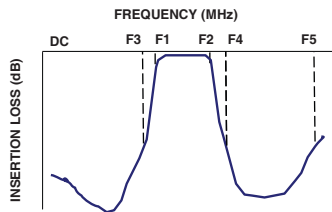

Electrical Specifications at 25°C

Parameter	F#	Frequency (MHz)	Min.	Typ.	Max.	Unit	
Pass Band	Center Frequency	—	—	840	—	MHz	
	Insertion Loss	F1-F2	790-890	—	0.6	2	dB
	VSWR	F1-F2	790-890	—	1.2	1.78	:1
Stop Band, Lower	Insertion Loss	DC-F3	DC-665	20	30	—	dB
	VSWR	DC-F3	DC-665	—	20	—	:1
Stop Band, Upper	Insertion Loss	F4-F5	1070-1600	20	30	—	dB
	VSWR	F4-F5	1070-1600	—	20	—	:1

Maximum Ratings

Operating Temperature	-40°C to 85°C
Storage Temperature	-55°C to 100°C
RF Power Input	5W

Permanent damage may occur if any of these limits are exceeded.

Typical Performance Data at 25°C

Frequency (MHz)	Insertion Loss (dB)	VSWR (:1)	Frequency (MHz)	Group Delay (nsec)
1	95.79	1737.18	790	6.06
575	53.61	65.95	795	5.81
665	30.37	54.78	800	5.61
710	16.25	32.88	805	5.43
730	9.00	13.89	810	5.29
745	4.10	5.01	815	5.17
755	2.02	2.58	820	5.07
765	1.07	1.59	825	4.98
790	0.63	1.05	830	4.90
810	0.58	1.09	835	4.84
840	0.56	1.15	840	4.80
890	0.55	1.01	845	4.76
930	1.53	2.30	850	4.73
945	3.69	4.94	855	4.73
960	7.14	10.89	860	4.73
995	16.04	32.74	865	4.75
1070	31.94	48.86	870	4.77
1220	64.07	53.13	880	4.84
1450	70.77	55.74	885	4.90
1600	43.61	46.99	890	4.98

+RoHS Compliant

The +Suffix identifies RoHS Compliance. See our web site for RoHS Compliance methodologies and qualifications

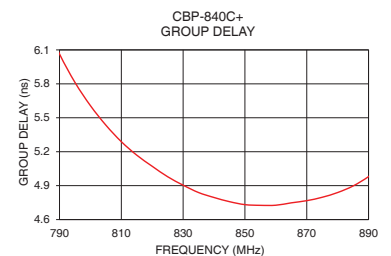
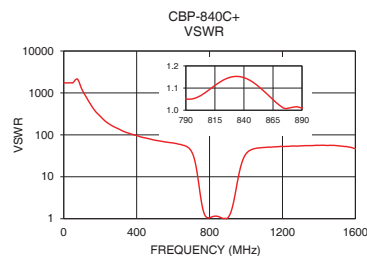
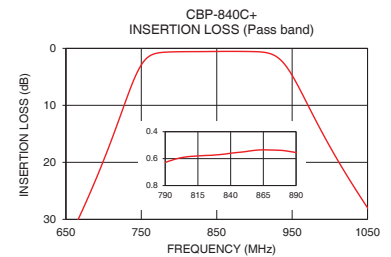
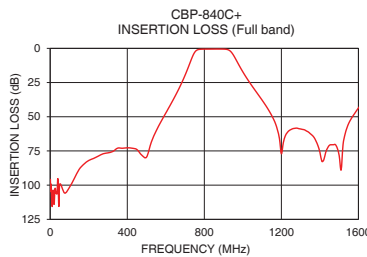

Notes

- Performance and quality attributes and conditions not expressly stated in this specification document are intended to be excluded and do not form a part of this specification document.
- Electrical specifications and performance data contained in this specification document are based on Mini-Circuits' applicable established test performance criteria and measurement instructions.
- The parts covered by this specification document are subject to Mini-Circuits standard limited warranty and terms and conditions (collectively, "Standard Terms"); Purchasers of this part are entitled to the rights and benefits contained therein. For a full statement of the Standard Terms and the exclusive rights and remedies thereunder, please visit Mini-Circuits' website at www.minicircuits.com/MCLStore/terms.jsp



www.minicircuits.com P.O. Box 350166, Brooklyn, NY 11235-0003 (718) 934-4500 sales@minicircuits.com

REV.B
M174392
CBP-840C+
EDU1802
URJ
200805
Page 2 of 3

Pad Connections

INPUT	1
OUTPUT	10
GROUND	2,3,4,5,6,7,8,9,11,12,13

Demo Board MCL P/N: TB-684+ Suggested PCB Layout (PL-373)

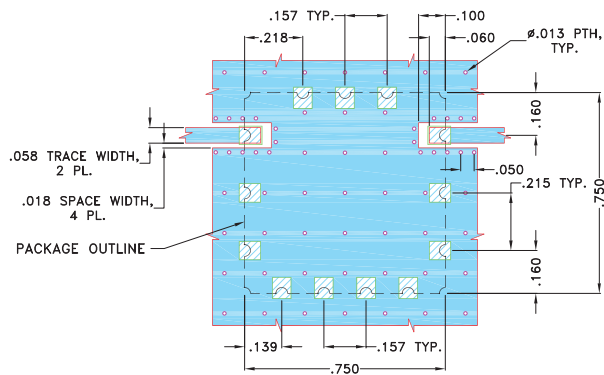

NOTES:

- TRACE WIDTH IS SHOWN FOR OAK (OAK-602) WITH DIELECTRIC THICKNESS .022" ± .0015". COPPER: 1/2 OZ. EACH SIDE. FOR OTHER MATERIALS TRACE WIDTH MAY NEED TO BE MODIFIED.
- BOTTOM SIDE OF THE PCB IS CONTINUOUS GROUND PLANE.

- DENOTES PCB COPPER LAYOUT WITH SMOBC (SOLDER MASK OVER BARE COPPER)
- DENOTES COPPER LAND PATTERN FREE OF SOLDERMASK

Outline Drawing

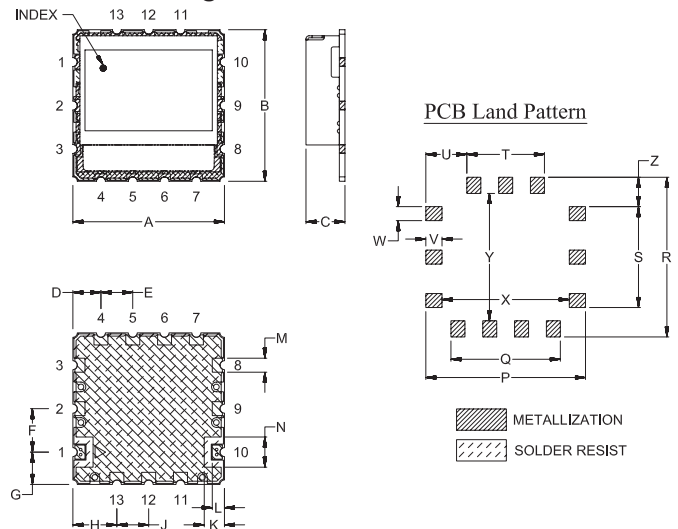

Outline Dimensions (inch mm)

A	B	C	D	E	F	G	H	J	K	L	M	N
.750	.750	.210	.139	.157	.215	.160	.218	.157	.100	.060	.069	.149
19.05	19.05	5.33	3.53	3.99	5.46	4.06	5.54	3.99	2.54	1.52	1.75	3.78
P	Q	R	S	T	U	V	W	X	Y	Z	wt.	
.790	.541	.790	.499	.384	.203	.080	.069	.630	.630	.145	grams	
20.07	13.74	20.07	12.67	9.75	5.16	2.03	1.75	16.00	16.00	3.68	4.6	

Note: Please refer to case style drawing for details

Notes

- Performance and quality attributes and conditions not expressly stated in this specification document are intended to be excluded and do not form a part of this specification document.
- Electrical specifications and performance data contained in this specification document are based on Mini-Circuits' applicable established test performance criteria and measurement instructions.
- The parts covered by this specification document are subject to Mini-Circuits standard limited warranty and terms and conditions (collectively, "Standard Terms"); Purchasers of this part are entitled to the rights and benefits contained therein. For a full statement of the Standard Terms and the exclusive rights and remedies thereunder, please visit Mini-Circuits' website at www.minicircuits.com/MCLStore/terms.jsp

Typical Performance Data

FREQ. (MHz)	INSERTION LOSS			INPUT RETURN LOSS			OUTPUT RETURN LOSS		
	(dB)			(dB)			(dB)		
	@-40°C	@+25°C	@+85°C	@-40°C	@+25°C	@+85°C	@-40°C	@+25°C	@+85°C
1	101.61	95.79	93.29	0.00	0.00	0.00	0.00	0.01	0.01
2	108.82	102.13	105.70	0.00	0.00	0.00	0.00	0.00	0.00
3	105.31	104.72	96.21	0.00	0.00	0.00	0.00	0.00	0.00
4	110.69	102.77	100.03	0.00	0.00	0.00	0.00	0.00	0.00
20	100.00	114.07	102.07	0.00	0.00	0.00	0.00	0.00	0.00
40	102.75	95.21	94.51	0.00	0.00	0.00	0.00	0.00	0.00
45	97.78	115.58	101.05	0.00	0.00	0.00	0.00	0.00	0.00
125	91.66	95.17	89.68	0.01	0.02	0.03	0.01	0.03	0.03
200	82.26	81.97	82.34	0.04	0.06	0.07	0.05	0.07	0.07
225	81.11	80.50	79.35	0.06	0.08	0.08	0.06	0.09	0.09
325	75.52	75.39	75.57	0.12	0.14	0.15	0.12	0.15	0.15
425	73.34	73.00	73.40	0.16	0.20	0.20	0.17	0.20	0.20
475	79.15	78.03	78.64	0.18	0.22	0.23	0.18	0.22	0.23
525	68.60	68.50	68.60	0.20	0.24	0.25	0.20	0.24	0.25
575	53.73	53.61	53.51	0.22	0.26	0.28	0.22	0.26	0.27
625	41.13	41.03	40.90	0.24	0.29	0.31	0.23	0.28	0.30
665	30.46	30.37	30.23	0.26	0.32	0.35	0.26	0.31	0.34
680	26.08	26.00	25.84	0.28	0.34	0.37	0.27	0.33	0.36
720	12.72	12.66	12.52	0.65	0.75	0.82	0.63	0.72	0.79
735	7.24	7.22	7.14	1.56	1.72	1.85	1.52	1.68	1.79
750	2.85	2.90	2.93	4.75	5.04	5.25	4.66	4.93	5.13
760	1.33	1.43	1.50	9.30	9.70	9.92	9.10	9.47	9.66
770	0.76	0.87	0.94	15.95	16.53	16.64	15.40	15.90	15.99
790	0.52	0.63	0.69	30.54	31.91	31.30	27.65	28.72	28.83
800	0.49	0.60	0.66	30.06	30.87	30.53	29.02	30.13	30.25
815	0.48	0.58	0.64	25.41	25.53	25.53	25.54	25.76	25.78
820	0.47	0.58	0.63	24.32	24.33	24.40	24.49	24.55	24.60
840	0.46	0.56	0.62	23.59	23.28	23.54	23.81	23.46	23.60
870	0.43	0.54	0.59	40.50	38.11	39.75	41.54	36.62	35.23
875	0.43	0.54	0.60	41.06	47.57	57.39	38.61	38.01	35.79
880	0.44	0.54	0.60	37.32	45.02	44.76	34.79	35.98	34.38
890	0.45	0.55	0.62	37.92	45.30	45.71	33.34	33.99	33.12
900	0.47	0.58	0.64	33.92	31.90	32.13	31.18	29.64	29.42
920	0.77	0.90	0.97	13.07	13.10	13.21	13.06	13.05	13.16
930	1.39	1.53	1.59	7.96	8.09	8.22	7.96	8.06	8.19
945	3.58	3.69	3.72	3.43	3.57	3.69	3.41	3.55	3.67
960	7.05	7.14	7.12	1.48	1.60	1.69	1.47	1.58	1.67
990	14.75	14.82	14.72	0.50	0.58	0.63	0.48	0.57	0.61
1000	17.15	17.23	17.11	0.42	0.49	0.54	0.41	0.48	0.52
1015	20.57	20.65	20.52	0.36	0.42	0.46	0.34	0.41	0.44
1030	23.81	23.88	23.74	0.33	0.39	0.42	0.31	0.38	0.41
1055	28.90	28.98	28.80	0.31	0.36	0.39	0.30	0.35	0.38
1060	29.90	29.98	29.80	0.31	0.36	0.39	0.29	0.35	0.37
1070	31.87	31.94	31.76	0.30	0.36	0.39	0.29	0.34	0.37
1100	37.82	37.90	37.66	0.30	0.35	0.37	0.28	0.34	0.36
1110	39.88	39.95	39.70	0.29	0.34	0.37	0.28	0.33	0.36
1180	59.97	59.86	59.14	0.28	0.33	0.36	0.27	0.32	0.34
1190	66.71	66.08	65.02	0.28	0.33	0.35	0.27	0.32	0.34
1200	78.52	77.11	75.42	0.28	0.33	0.35	0.27	0.31	0.34
1230	61.48	61.68	61.83	0.27	0.33	0.35	0.26	0.31	0.33
1260	58.66	58.70	58.75	0.27	0.32	0.35	0.26	0.31	0.33
1270	58.37	58.47	58.53	0.27	0.32	0.35	0.25	0.31	0.33
1300	59.04	58.95	59.11	0.27	0.32	0.34	0.25	0.31	0.33
1350	62.44	62.39	62.08	0.26	0.31	0.34	0.24	0.30	0.32
1410	82.85	82.60	81.57	0.25	0.31	0.34	0.24	0.30	0.32
1450	70.95	70.77	70.43	0.25	0.31	0.34	0.23	0.29	0.32
1480	70.97	70.36	69.85	0.24	0.31	0.34	0.23	0.30	0.32
1510	83.13	88.96	101.00	0.25	0.32	0.35	0.23	0.30	0.33
1530	62.79	63.01	63.80	0.25	0.32	0.36	0.24	0.30	0.33
1600	43.59	43.61	43.69	0.29	0.37	0.42	0.25	0.33	0.37

Typical Performance Data

FREQ. (MHz)	GROUP DELAY		
	(nsec)		
	@-40°C	@+25°C	@+85°C
790	6.10	6.06	6.01
795	5.85	5.81	5.77
800	5.64	5.61	5.57
805	5.46	5.43	5.40
810	5.32	5.29	5.25
815	5.20	5.17	5.14
820	5.10	5.07	5.04
825	5.00	4.98	4.96
830	4.93	4.90	4.88
835	4.86	4.84	4.81
840	4.82	4.80	4.77
845	4.78	4.76	4.73
850	4.75	4.73	4.71
855	4.75	4.73	4.70
860	4.75	4.73	4.71
865	4.77	4.75	4.72
870	4.79	4.77	4.75
875	4.82	4.80	4.77
880	4.86	4.84	4.81
885	4.91	4.90	4.87
890	4.99	4.98	4.94

Typical Performance Curves

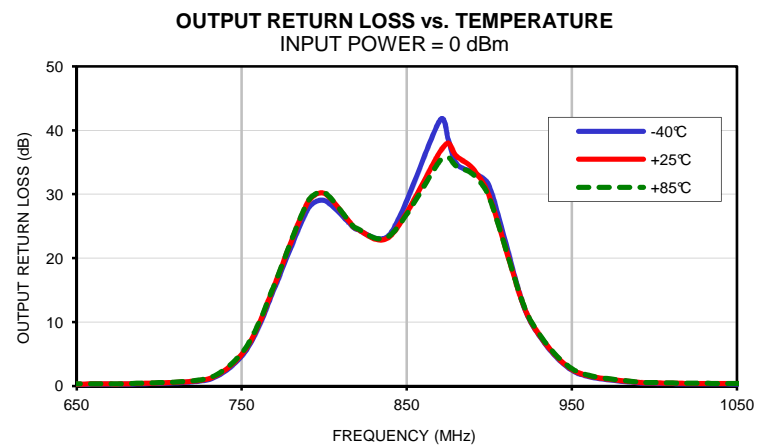
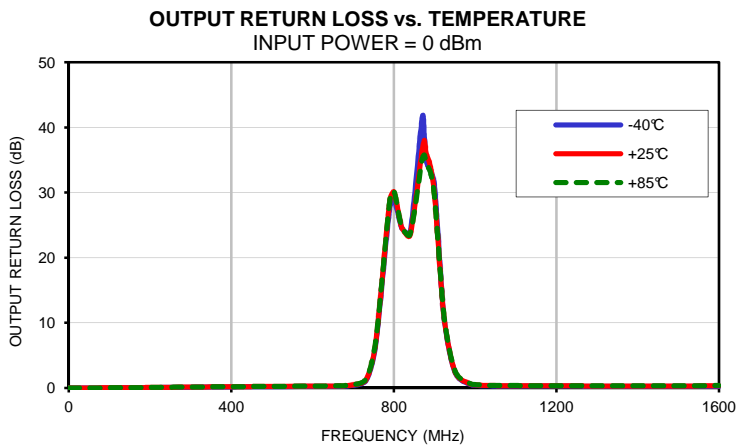
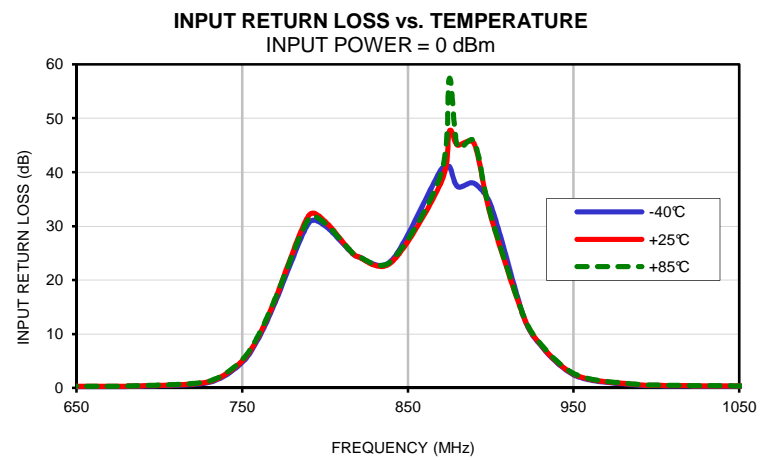
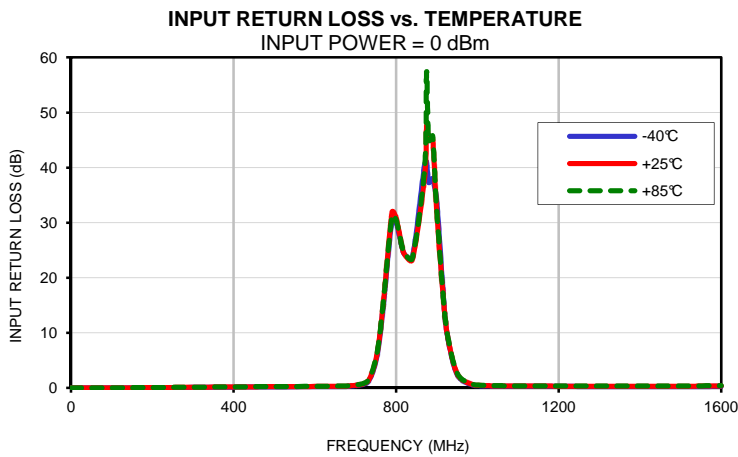
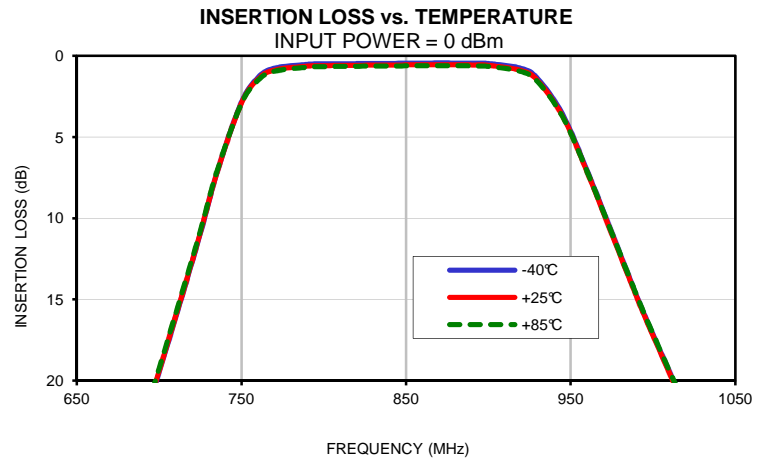
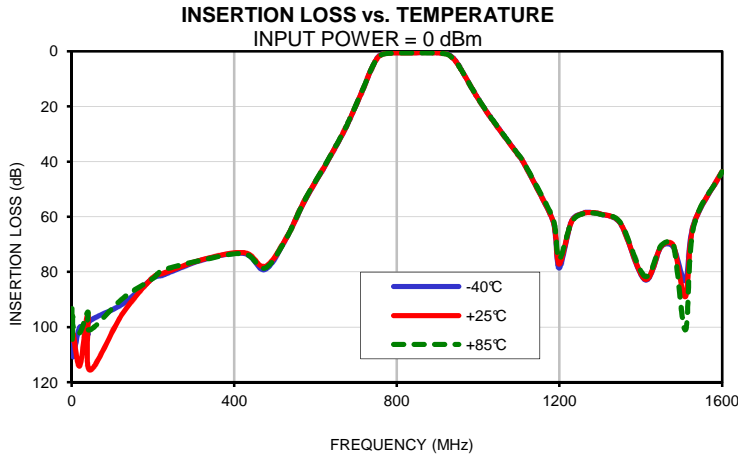

Band Pass Filter

CBP-840C+

Typical Performance Curves

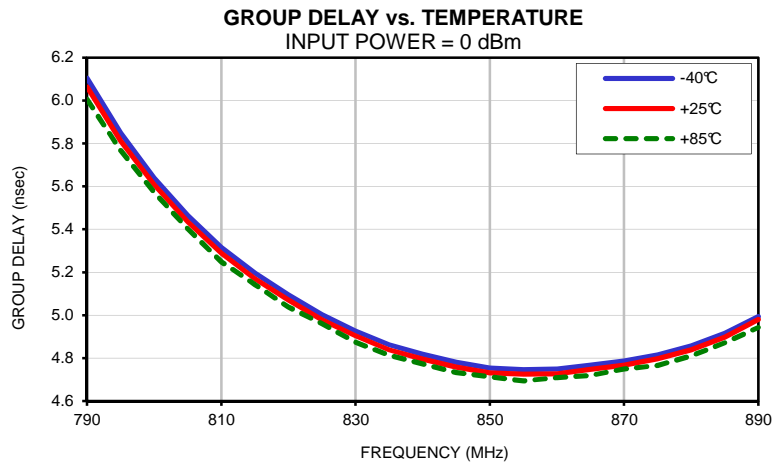

P.O. Box 350166, Brooklyn, New York 11235-0003 (718) 934-4500 • Fax (718) 332-4661 For detailed performance specs & shopping online see Mini-Circuits web site



The Design Engineers Search Engine Provides ACTUAL Data Instantly From MINI-CIRCUITS At: www.minicircuits.com

IF/RF MICROWAVE COMPONENTS

REV. OR
CBP-840C+
130408
Page 2 of 2

Outline Dimensions

MP1766



PCB Land Pattern

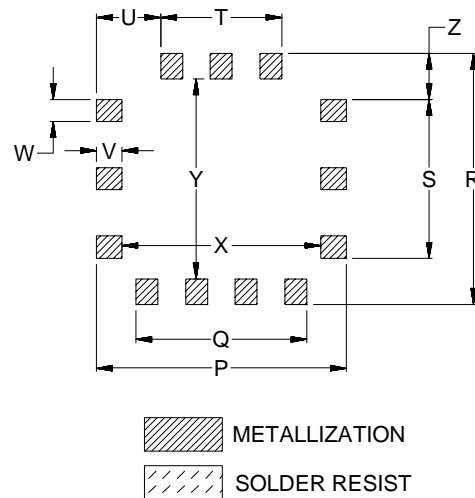

CASE#	A	B	C	D	E	F	G	H	J	K	L	M	N
MP1766	.750 (19.05)	.750 (19.05)	.210 (5.33)	.139 (3.53)	.157 (3.99)	.215 (5.46)	.160 (4.06)	.218 (5.54)	.157 (3.99)	.100 (2.54)	.060 (1.52)	.069 (1.75)	.149 (3.78)

CASE#	P	Q	R	S	T	U	V	W	X	Y	Z	WT.GRAMS
MP1766	.790 (20.07)	.541 (13.74)	.790 (20.07)	.499 (12.67)	.384 (9.75)	.203 (5.16)	.080 (2.03)	.069 (1.75)	.630 (16.00)	.630 (16.00)	.145 (3.68)	4.6

Dimensions are in inches (mm). Tolerances: 2PL. ± .03; 3PL. ± .015

Notes:

- Case material: Nickel-Silver alloy.
- Base: Printed wiring laminate.
- Termination finish:
For RoHS Case Styles: 2-5 μ inch (.05-.13 microns) Gold over 120-240 μ inch (3.05-6.10 microns) Nickel plate.
All models, (+) suffix.

Mini-Circuits®
ISO 9001 ISO 14001 CERTIFIED

ALL NEW
minicircuits.com

P.O. Box 350166, Brooklyn, New York 11235-0003 (718) 934-4500 Fax (718) 332-4661 For detailed performance specs & shopping online see Mini-Circuits web site



The Design Engineers Search Engine Provides ACTUAL Data Instantly From MINI-CIRCUITS At: www.minicircuits.com

RF/IF MICROWAVE COMPONENTS

Tape & Reel Packaging TR-F111

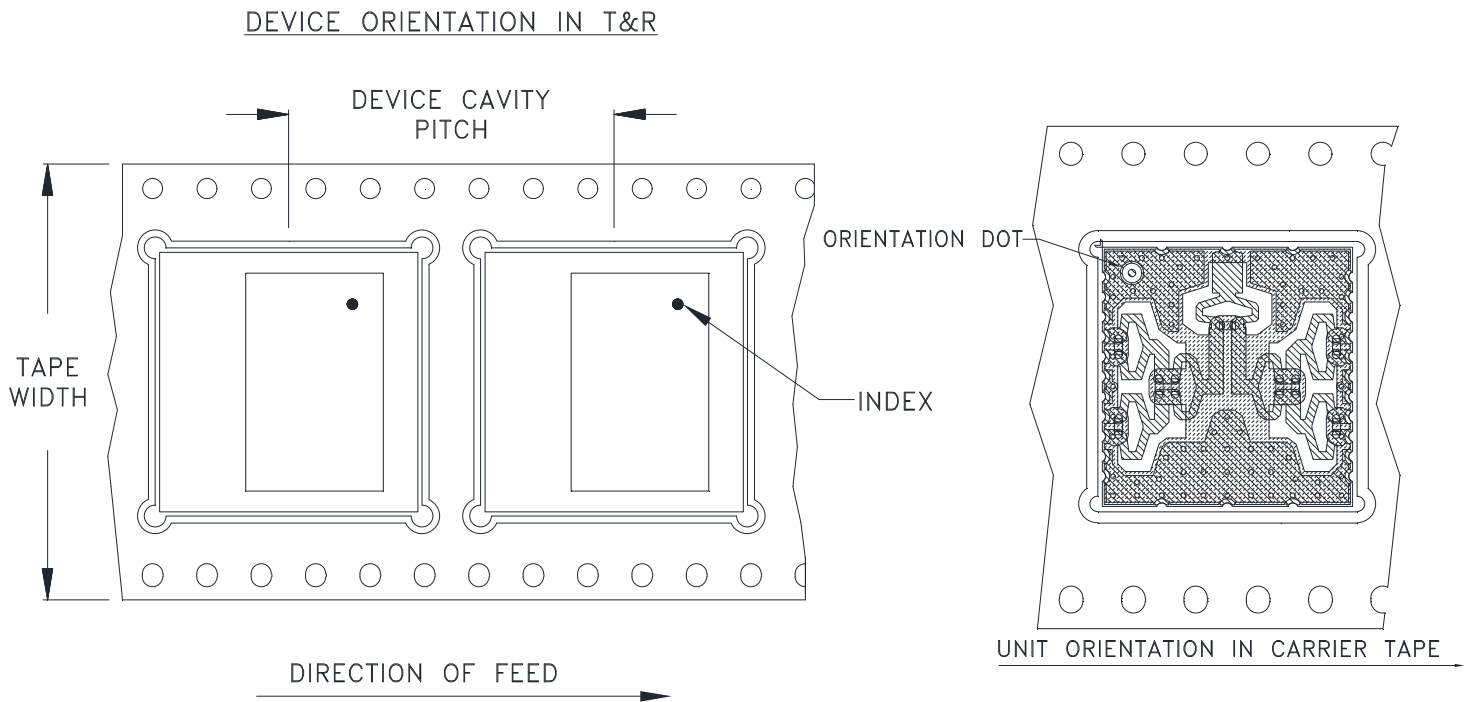

Applicable Case styles:

Applicable Case styles:RS1539

Tape Width, mm	Device Cavity Pitch, mm	Reel Size, inches	Devices per Reel
32	24	13	250

Mini-Circuits carrier tape materials provide protection from ESD (Electro-Static Discharge) during handling and transportation. Tapes are static dissipative and comply with industry standards EIA-481/EIA-541.

Go to: www.minicircuits.com/pages/pdfs/tape.pdf



INTERNET <http://www.minicircuits.com>

P.O. Box 350166, Brooklyn, New York 11235-0003 (718) 934-4500 Fax (718) 332-4661

Distribution Centers NORTH AMERICA 800-654-7949 • 417-335-5935 • Fax 417-335-5945 • EUROPE 44-1252-832600 • Fax 44-1252-837010

Mini-Circuits ISO 9001 & ISO 14001 Certified

THIRD ANGLE PROJECTION

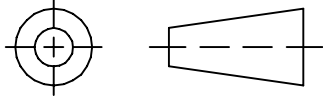

REVISIONS

REV	ECN No.	DESCRIPTION	DATE	DR	AUTH
OR	M137721	NEW RELEASE	JUN 12	DDR	KG

SUGGESTED MOUNTING CONFIGURATION FOR
MP1766 CASE STYLE "13FL01" PIN CODE



NOTES:

- TRACE WIDTH IS SHOWN FOR OAK (OAK-602) WITH DIELECTRIC THICKNESS .022"±.0015". COPPER: 1/2 OZ. EACH SIDE.
FOR OTHER MATERIALS TRACE WIDTH MAY NEED TO BE MODIFIED.
- BOTTOM SIDE OF THE PCB IS CONTINUOUS GROUND PLANE.

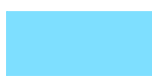
 DENOTES PCB COPPER LAYOUT WITH SMOBC
(SOLDER MASK OVER BARE COPPER)

 DENOTES COPPER LAND PATTERN FREE OF SOLDERMASK

UNLESS OTHERWISE SPECIFIED	INITIALS	DATE
DIMENSIONS ARE IN INCHES	DRAWN DDR	22 JUN 12
TOLERANCES ON: 2 PL DECIMALS ±	CHECKED MD	22 JUN 12
3 PL DECIMALS ± .005"	APPROVED GM	22 JUN 12
ANGLES ±		
FRACTIONS ±		

 **Mini-Circuits®** 13 Neptune Avenue
Brooklyn NY 11235

PL, 13FL01, MP1766, BPF,
TB-684+, 50 Ohm

SIZE A	CODE IDENT 15542	DRAWING NO: 98-PL-373	REV: OR
FILE: 98PL373	SCALE: 4:1	SHEET: 1 OF 1	

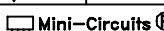
 Mini-Circuits®
THIS DOCUMENT AND ITS CONTENTS ARE THE PROPERTY OF MINI-CIRCUITS.
EXCEPT FOR USE EXPRESSLY GRANTED, IN WRITING, TO ITS VENDORS, VENDEE
AND THE UNITED STATES GOVERNMENT, MINI-CIRCUITS RESERVES ALL PROPRIETARY
DESIGN, USE, MANUFACTURING AND REPRODUCTION RIGHTS THERE TO.
THESE CONTENTS SHALL NOT BE USED, DUPLICATED OR DISCLOSED TO ANY OUTSIDE
PARTY, IN WHOLE OR IN PART, WITHOUT WRITTEN PERMISSION OF MINI-CIRCUITS.

Evaluation Board and Circuit

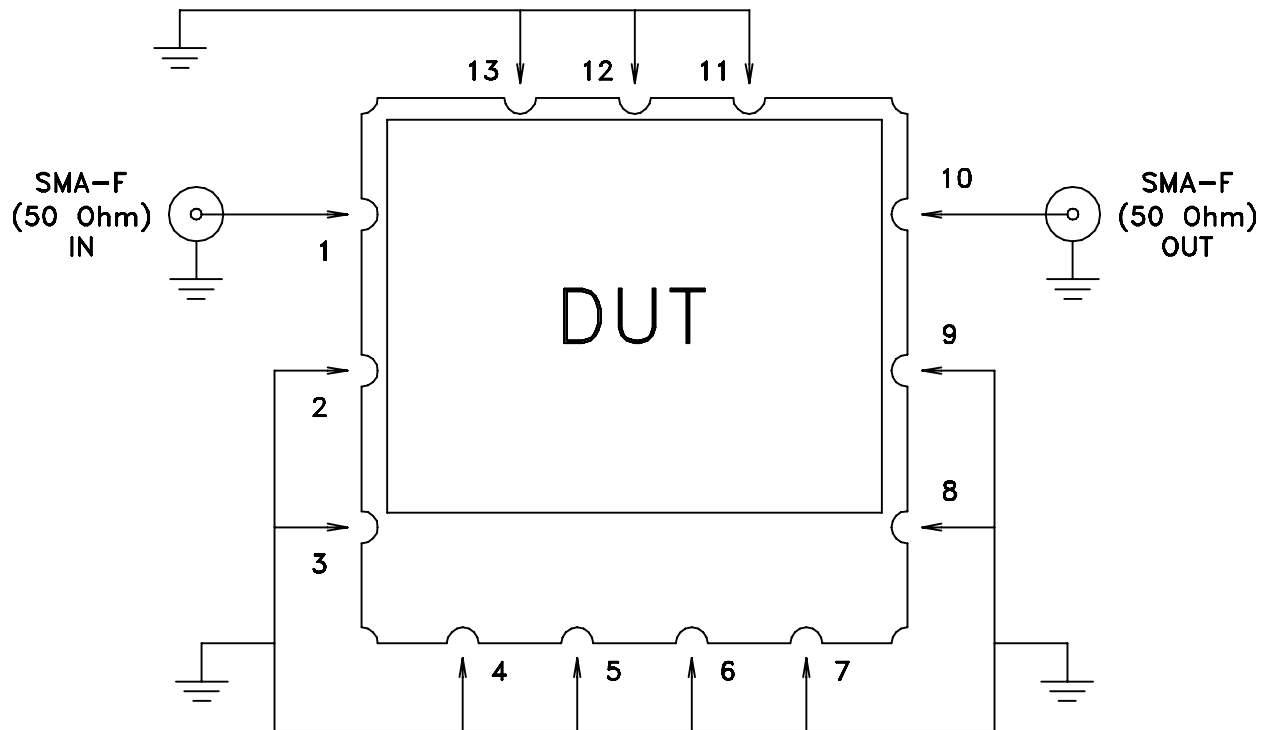
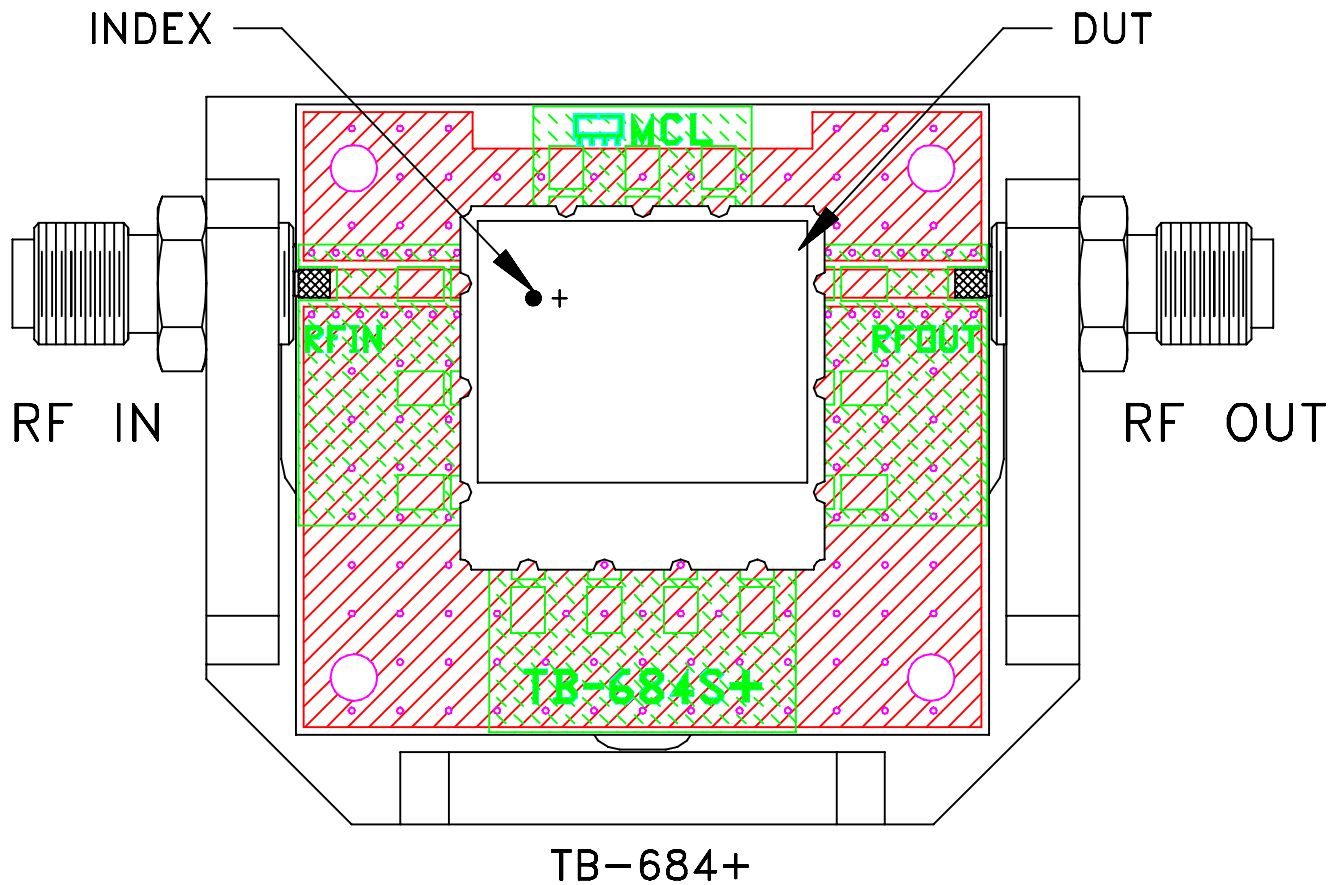

Schematic Diagram

Notes:

1. 50 Ohm SMA Female connectors.
2. PCB Material: OAK-602 OR Equivalent
Dielectric Constant=2.50±.04, Thickness=.022 inch.

 Mini-Circuits®

All Mini-Circuits products are manufactured under exacting quality assurance and control standards, and are capable of meeting published specifications after being subjected to any or all of the following physical and environmental test.

Specification	Test/Inspection Condition	Reference/Spec
Operating Temperature	-40° to 85°C Ambient Environment	Individual Model Data Sheet
Storage Temperature	-55° to 100° C Ambient Environment	Individual Model Data Sheet
Humidity	90 to 95% RH, 96 hours, 40°C	MIL-STD-202, Method 103B, Condition B, Except 50°C
Thermal Shock	-55° to 100°C, 100 cycles	MIL-STD-202, Method 107, Condition A-3, except +100°C
Solder Reflow Heat	Sn-Pb Eutectic Process: 225°C peak Pb-Free Process, 245°C peak	J-STD-020, Table 4-1, 4-2 and 5-2, Figure 5-1
Solderability	10X Magnification	J-STD-002, Para 4.2.5, Test S, 95% Coverage
Vibration (High Frequency)	20g peak, 10-2000 Hz, 4 times in each of three axes (total 12)	MIL-STD-202, Method 204, Condition D
Mechanical Shock	50g, 11 ms, 1/2-sine, 18 shocks: 3 each direction, each of 3 axes	MIL-STD-202, Method 213, Condition A