

Surface Mount Bandpass Filter

CBP-1400E+

50Ω 1320 to 1480 MHz

The Big Deal

- Low-profile shielded package
- Low passband Insertion Loss
- Excellent Rejection

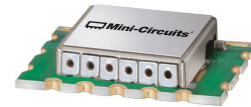

Generic photo used for illustration purposes only
CASE STYLE: LW1611

Product Overview

CBP-1400E+ is a ceramic-coaxial-resonator based bandpass filter in a shielded package (size of 0.638" x 0.434" x 0.105") fabricated using SMT technology. This filter offers outstanding close in rejection, low insertion loss and high power handling for use in broadband, fixed wireless, image rejection and point-to-point radio. In addition, this model uses low profile resonators which gives very good size advantage.

Key Features

Feature	Advantages
High Selectivity	The CBP-1400E+ filter incorporates High-Q ceramic resonators that enables sharp rejection near passband.
Low Passband VSWR	This filter maintains typical VSWR over a wide passband frequency range making this filter easier to integrate into receiver and transmitter RF chains with less concerns for in band frequency ripple.
Rugged construction	The CBP-1400E+ has been qualified over wide range of thermal, mechanical and environmental conditions including withstanding the stress of extensive solder reflow cycles.

Notes

- A. Performance and quality attributes and conditions not expressly stated in this specification document are intended to be excluded and do not form a part of this specification document.
B. Electrical specifications and performance data contained in this specification document are based on Mini-Circuit's applicable established test performance criteria and measurement instructions.
C. The parts covered by this specification document are subject to Mini-Circuits standard limited warranty and terms and conditions (collectively, "Standard Terms"); Purchasers of this part are entitled to the rights and benefits contained therein. For a full statement of the Standard Terms and the exclusive rights and remedies thereunder, please visit Mini-Circuits' website at www.minicircuits.com/MCLStore/terms.jsp



Surface Mount Bandpass Filter

CBP-1400E+

50Ω 1320 to 1480 MHz

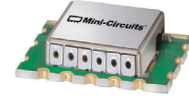

Generic photo used for illustration purposes only

CASE STYLE: LW1611

Features

- Low Insertion loss
- Minimal Insertion loss variation over operating temperature
- Low-profile shielded package

Applications

- Wireless medical telemetry
- Satellite digital audio broad casting
- Aeronautical radio navigation

Electrical Specifications at 25°C

Parameter	F#	Frequency (MHz)	Min.	Typ.	Max.	Unit
Pass Band	Center Frequency	—	—	1400	—	MHz
	Insertion Loss	F1-F2	1320-1480	1.7	3	dB
	VSWR	F1-F2	1320-1480	1.5	2.3	:1
Stop Band, Lower	Insertion Loss	DC-F3	DC-1150	20	42	dB
	VSWR	DC-F3	DC-1150	—	36	:1
Stop Band, Upper	Insertion Loss	F4-F5	1600-2400	20	31	dB
	VSWR	F4-F5	1600-2400	—	20	:1

Maximum Ratings

Operating Temperature	-40°C to 85°C
Storage Temperature	-55°C to 100°C
RF Power Input*	12.6W max. at 25°C

* Derate linearly to 6.5W at 85°C
Permanent damage may occur if any of these limits are exceeded.

Functional Schematic

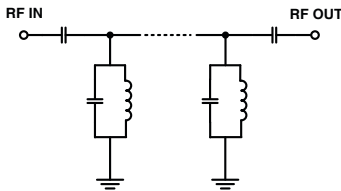

Typical Frequency Response

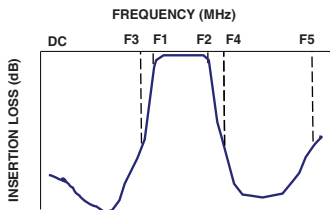

Typical Performance Data at 25°C

Frequency (MHz)	Insertion Loss (dB)	VSWR (:1)	Frequency (MHz)	Group Delay (nsec)
1	99.11	1737.18	1320	6.30
800	66.14	69.49	1330	6.06
1150	46.82	40.41	1340	5.86
1160	43.30	38.61	1350	5.69
1180	36.06	32.18	1360	5.55
1200	28.23	24.83	1370	5.43
1220	19.30	15.67	1380	5.36
1240	9.28	5.85	1390	5.33
1320	1.56	1.07	1395	5.33
1400	1.41	1.27	1400	5.34
1480	1.58	1.02	1405	5.36
1530	5.42	3.36	1410	5.39
1540	9.03	6.28	1420	5.45
1550	13.22	10.37	1425	5.48
1575	23.49	20.70	1430	5.52
1600	32.78	28.49	1440	5.59
1610	36.45	31.03	1450	5.71
1650	54.03	39.49	1460	5.88
2000	54.44	59.91	1470	6.14
2400	60.59	54.29	1480	6.49

+RoHS Compliant
The +Suffix identifies RoHS Compliance. See our web site for RoHS Compliance methodologies and qualifications

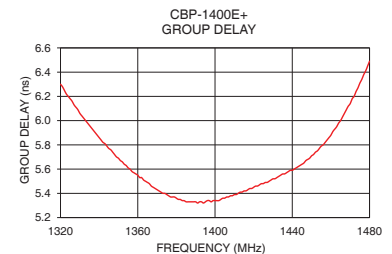
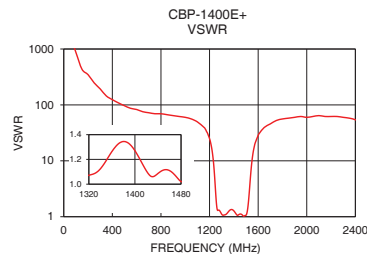
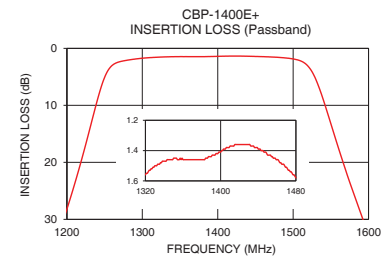
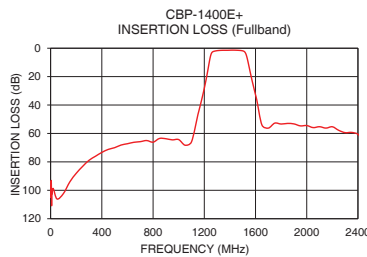

Notes

- Performance and quality attributes and conditions not expressly stated in this specification document are intended to be excluded and do not form a part of this specification document.
- Electrical specifications and performance data contained in this specification document are based on Mini-Circuit's applicable established test performance criteria and measurement instructions.
- The parts covered by this specification document are subject to Mini-Circuits standard limited warranty and terms and conditions (collectively, "Standard Terms"); Purchasers of this part are entitled to the rights and benefits contained therein. For a full statement of the Standard Terms and the exclusive rights and remedies thereunder, please visit Mini-Circuits' website at www.minicircuits.com/MCLStore/terms.jsp



www.minicircuits.com P.O. Box 350166, Brooklyn, NY 11235-0003 (718) 934-4500 sales@minicircuits.com

REV.B
M174392
CBP-1400E+
EDU1470/2
URJ
200812
Page 2 of 3

Pad Connections

INPUT	1
OUTPUT	11
GROUND	2,3,4,5,6,7,8,9,10,12,13,14,15,16

Demo Board MCL P/N: TB-611+
Suggested PCB Layout (PL-338)

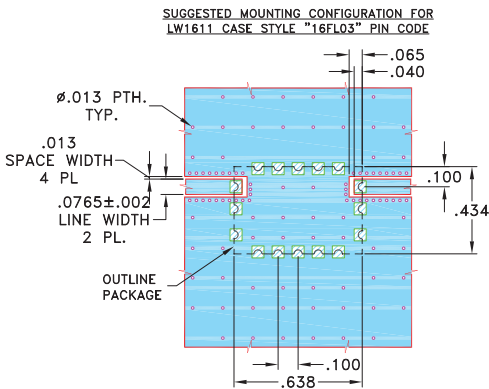

- NOTES:
- TRACE WIDTH IS SHOWN FOR ROGERS R04350B WITH DIELECTRIC THICKNESS .060"±.004". COPPER: 1/2 OZ. EACH SIDE.
 FOR OTHER MATERIALS TRACE WIDTH MAY NEED TO BE MODIFIED.
 - BOTTOM SIDE OF THE PCB IS CONTINUOUS GROUND PLANE.

- DENOTES PCB COPPER LAYOUT WITH SMOBC (SOLDER MASK OVER BARE COPPER)
- DENOTES COPPER LAND PATTERN FREE OF SOLDERMASK

Outline Drawing

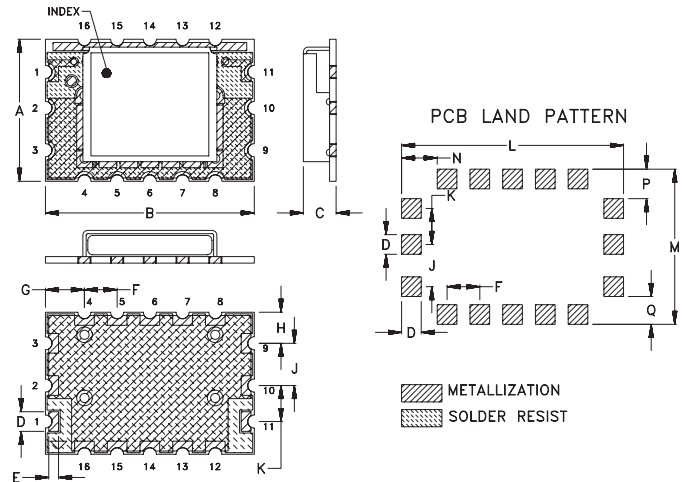

Outline Dimensions (inch / mm)

A	B	C	D	E	F	G	H	J	K	L	M
.434	.638	.120	.060	.030	.100	.119	.095	.129	.110	.678	.474
11.02	16.21	3.05	1.52	0.76	2.54	3.02	2.41	3.28	2.79	17.22	12.04
N	P	Q	wt,								
.109	.090	.085	grams								
2.77	2.29	2.16	0.8								

Note: Please refer to case style drawing for details

Notes

- Performance and quality attributes and conditions not expressly stated in this specification document are intended to be excluded and do not form a part of this specification document.
- Electrical specifications and performance data contained in this specification document are based on Mini-Circuit's applicable established test performance criteria and measurement instructions.
- The parts covered by this specification document are subject to Mini-Circuits standard limited warranty and terms and conditions (collectively, "Standard Terms"); Purchasers of this part are entitled to the rights and benefits contained therein. For a full statement of the Standard Terms and the exclusive rights and remedies thereunder, please visit Mini-Circuits' website at www.minicircuits.com/MCLStore/terms.jsp

Typical Performance Data

FREQ. (MHz)	INSERTION LOSS			INPUT RETURN LOSS			OUTPUT RETURN LOSS		
	(dB)			(dB)			(dB)		
	@-40°C	@+25°C	@+85°C	@-40°C	@+25°C	@+85°C	@-40°C	@+25°C	@+85°C
1	99.50	99.11	100.79	0.00	0.00	0.00	0.00	0.00	0.00
2	91.19	105.04	106.88	0.00	0.00	0.00	0.00	0.00	0.00
5	108.76	93.17	100.08	0.00	0.00	0.00	0.00	0.00	0.00
7	102.47	109.06	98.01	0.00	0.00	0.00	0.00	0.00	0.00
9	103.94	100.47	103.50	0.00	0.00	0.00	0.00	0.00	0.00
50	105.96	106.12	97.81	0.00	0.01	0.01	0.00	0.01	0.01
100	100.14	102.29	104.14	0.01	0.02	0.02	0.01	0.02	0.02
150	95.30	94.08	93.06	0.02	0.03	0.04	0.02	0.04	0.04
250	84.06	83.18	83.18	0.05	0.07	0.08	0.05	0.07	0.08
400	73.59	73.34	73.62	0.11	0.13	0.15	0.11	0.14	0.15
550	68.31	68.16	68.32	0.16	0.19	0.22	0.15	0.20	0.22
900	63.89	63.71	63.81	0.22	0.28	0.31	0.22	0.27	0.30
1050	67.94	68.28	68.67	0.24	0.31	0.36	0.24	0.31	0.35
1150	46.92	46.82	46.67	0.33	0.43	0.49	0.34	0.43	0.48
1165	41.63	41.51	41.42	0.37	0.47	0.54	0.38	0.47	0.53
1195	30.38	30.27	30.27	0.52	0.66	0.74	0.52	0.65	0.72
1205	26.23	26.12	26.15	0.63	0.78	0.88	0.62	0.76	0.85
1215	21.77	21.66	21.73	0.80	0.99	1.10	0.78	0.96	1.05
1233	12.84	12.80	13.01	1.72	2.04	2.19	1.64	1.92	2.05
1241	8.74	8.80	9.07	3.03	3.50	3.65	2.83	3.23	3.36
1249	5.23	5.44	5.74	6.19	6.86	6.94	5.64	6.17	6.22
1259	2.81	3.12	3.39	16.79	17.77	17.30	13.22	13.55	13.29
1281	1.80	2.06	2.24	17.09	17.57	17.68	17.31	17.83	17.73
1297	1.54	1.78	1.94	20.26	20.67	20.55	23.31	24.02	23.53
1318	1.35	1.57	1.71	25.62	26.13	26.07	29.44	29.48	29.80
1320	1.34	1.56	1.70	26.14	26.69	26.59	29.17	29.18	29.44
1327	1.30	1.52	1.65	28.24	28.91	28.59	28.46	28.24	28.29
1331	1.28	1.50	1.63	29.35	29.87	29.53	27.84	27.46	27.52
1334	1.28	1.49	1.62	29.59	29.79	29.70	27.10	26.65	26.78
1336	1.26	1.48	1.61	29.32	29.34	29.46	26.52	26.05	26.26
1339	1.26	1.47	1.60	28.21	28.03	28.48	25.50	25.04	25.38
1343	1.25	1.46	1.59	26.16	25.92	26.65	23.97	23.59	24.08
1354	1.25	1.46	1.58	21.13	21.09	21.92	20.19	20.09	20.75
1359	1.25	1.45	1.57	19.55	19.59	20.38	18.88	18.89	19.55
1360	1.25	1.46	1.57	19.30	19.35	20.14	18.66	18.68	19.35
1385	1.26	1.45	1.56	16.69	16.97	17.52	16.46	16.74	17.24
1393	1.23	1.43	1.54	17.27	17.61	18.05	17.04	17.36	17.77
1396	1.22	1.42	1.53	17.67	18.02	18.42	17.44	17.78	18.14
1400	1.21	1.41	1.53	18.39	18.76	19.08	18.12	18.48	18.77
1402	1.21	1.40	1.52	18.83	19.22	19.49	18.55	18.92	19.16
1405	1.19	1.39	1.51	19.62	20.03	20.23	19.28	19.68	19.83
1409	1.18	1.38	1.50	20.94	21.40	21.45	20.50	20.91	20.93
1412	1.17	1.37	1.49	22.17	22.66	22.59	21.58	22.01	21.90
1456	1.24	1.45	1.56	24.75	25.17	26.86	24.61	25.19	27.12
1471	1.30	1.52	1.64	28.09	28.49	29.73	28.89	30.07	32.79
1480	1.35	1.58	1.71	33.46	33.03	32.47	36.81	39.57	40.24
1497	1.55	1.80	1.94	39.01	35.60	33.38	31.42	31.24	30.71
1511	1.99	2.27	2.40	18.24	18.77	19.61	17.85	18.47	19.34
1526	4.08	4.33	4.32	6.62	7.04	7.63	6.61	7.05	7.66
1535	6.92	7.10	6.92	3.46	3.80	4.20	3.46	3.80	4.22
1550	13.17	13.22	12.85	1.47	1.69	1.89	1.47	1.68	1.89
1565	19.52	19.51	19.05	0.90	1.06	1.17	0.89	1.04	1.16
1600	32.88	32.78	32.23	0.52	0.64	0.70	0.51	0.61	0.68
1700	56.24	56.24	56.49	0.31	0.40	0.45	0.30	0.38	0.43
2400	60.58	60.59	61.52	0.22	0.35	0.43	0.21	0.32	0.40
2500	57.76	57.40	57.94	0.32	0.46	0.55	0.29	0.41	0.49
2620	44.63	44.32	44.57	1.67	1.95	2.10	0.94	1.13	1.25
2650	27.20	27.22	27.45	4.98	5.73	6.09	1.95	2.24	2.41
2680	15.74	16.06	16.37	6.93	7.38	7.65	5.79	6.53	6.98
2800	10.66	10.85	11.04	1.46	1.66	1.78	1.36	1.54	1.65

Band Pass Filter**CBP-1400E+***Typical Performance Data*

FREQ. (MHz)	GROUP DELAY		
	(nsec)		
	@-40°C	@+25°C	@+85°C
1320	6.35	6.30	6.28
1321	6.32	6.28	6.25
1322	6.29	6.25	6.23
1323	6.27	6.22	6.20
1324	6.24	6.20	6.18
1325	6.21	6.18	6.15
1326	6.19	6.16	6.13
1328	6.14	6.11	6.08
1330	6.10	6.06	6.03
1332	6.06	6.02	5.99
1334	6.01	5.98	5.95
1336	5.98	5.94	5.91
1338	5.94	5.90	5.87
1340	5.90	5.86	5.84
1342	5.86	5.82	5.80
1344	5.83	5.79	5.77
1346	5.79	5.76	5.73
1348	5.76	5.72	5.69
1350	5.72	5.69	5.66
1352	5.70	5.66	5.64
1354	5.67	5.63	5.61
1356	5.64	5.60	5.58
1358	5.61	5.57	5.55
1360	5.58	5.55	5.53
1362	5.56	5.53	5.50
1364	5.53	5.50	5.48
1366	5.51	5.48	5.46
1368	5.48	5.45	5.43
1370	5.46	5.43	5.41
1372	5.44	5.41	5.39
1375	5.42	5.39	5.37
1378	5.40	5.37	5.35
1381	5.38	5.35	5.33
1389	5.36	5.33	5.31
1391	5.35	5.32	5.30
1395	5.36	5.33	5.31
1397	5.36	5.34	5.31
1400	5.37	5.34	5.31
1403	5.38	5.35	5.32
1405	5.39	5.36	5.33
1409	5.41	5.38	5.34
1411	5.43	5.39	5.36
1417	5.47	5.43	5.39
1423	5.50	5.47	5.43
1427	5.53	5.49	5.45
1435	5.59	5.56	5.51
1439	5.62	5.59	5.55
1444	5.66	5.63	5.59
1448	5.71	5.68	5.64
1452	5.78	5.74	5.70
1457	5.86	5.82	5.78
1463	5.99	5.95	5.90
1467	6.10	6.06	6.01
1469	6.16	6.12	6.06
1471	6.22	6.18	6.12
1473	6.28	6.24	6.17
1475	6.35	6.31	6.24
1477	6.42	6.38	6.30
1479	6.50	6.45	6.38
1480	6.54	6.49	6.42

Typical Performance Curves

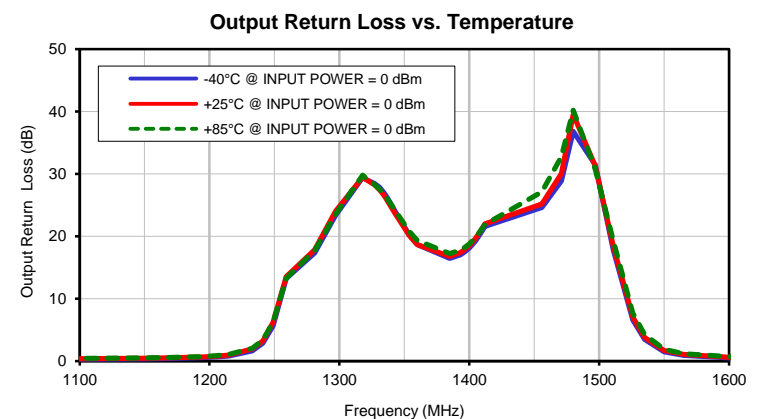
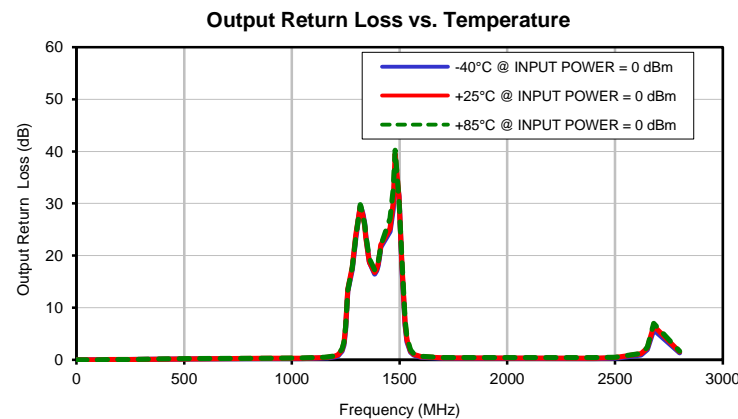
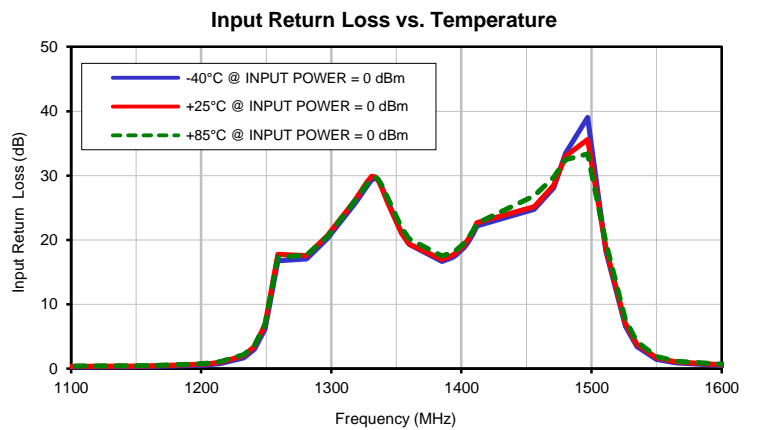
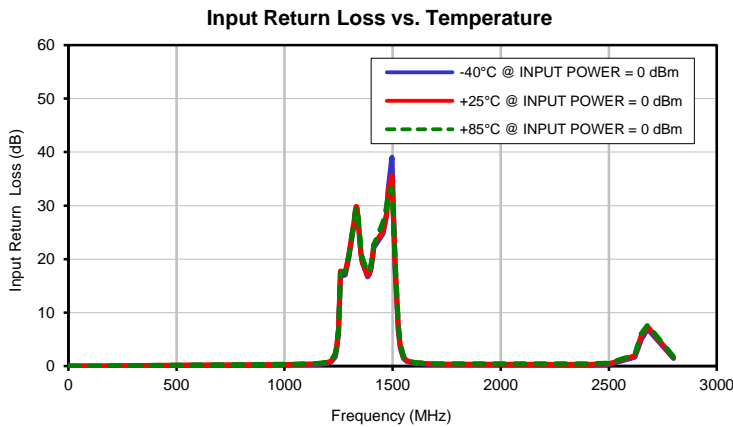
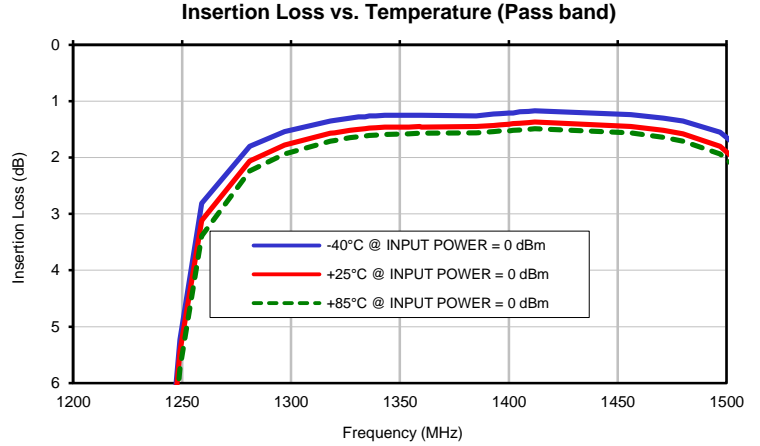
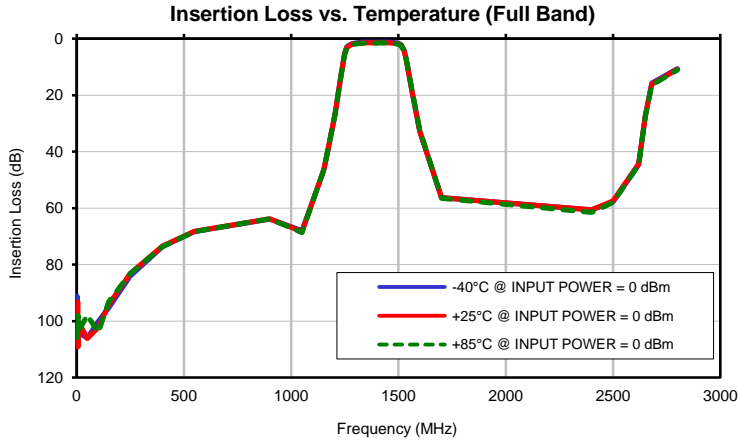

Band Pass Filter

CBP-1400E+

Typical Performance Curves

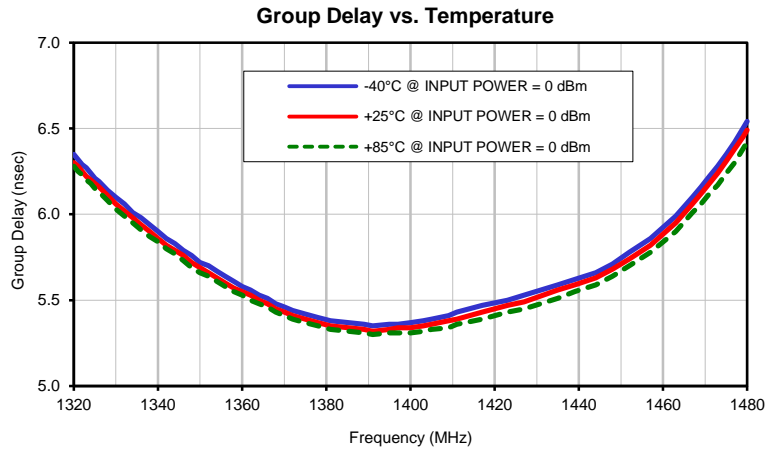

Outline Dimensions

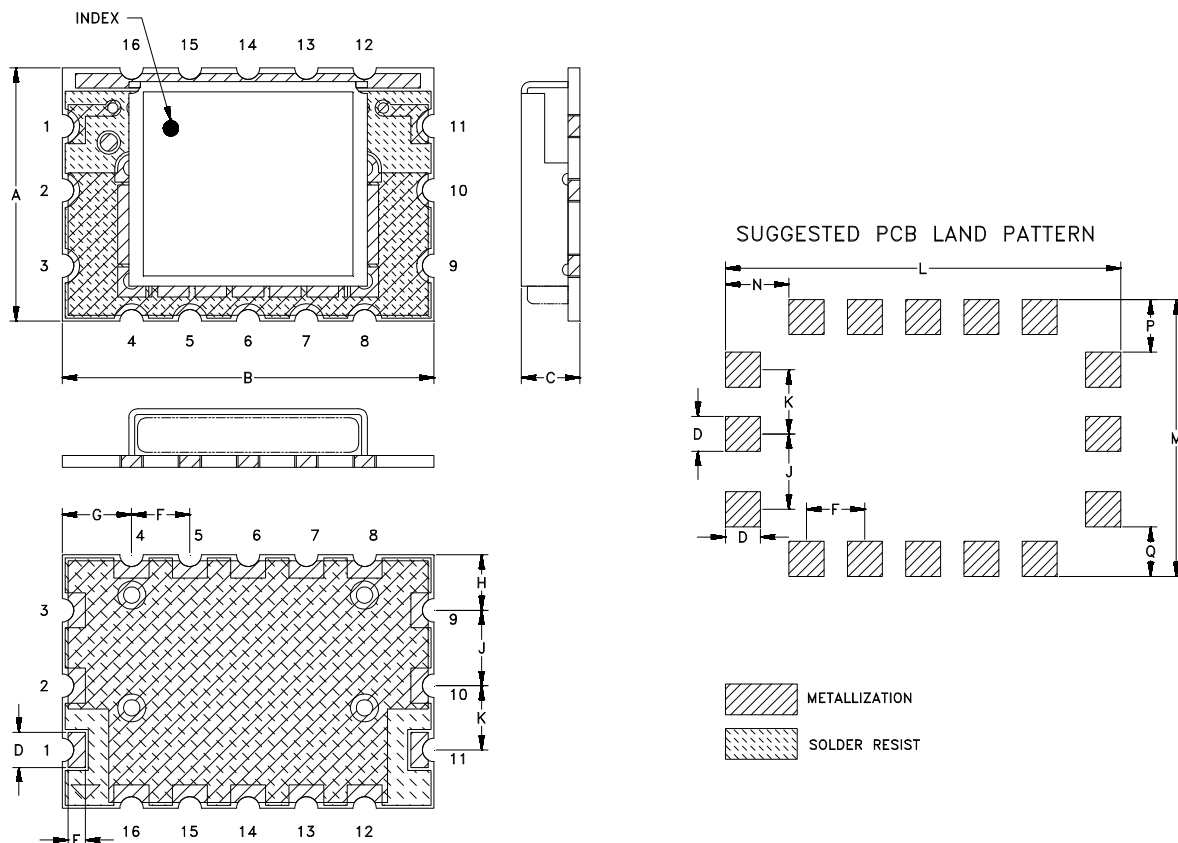

CASE#	A	B	C	D	E	F	G	H	J	K	L	M
LW1611	.434 (11.02)	.638 (16.21)	.120 (3.05)	.060 (1.52)	.030 (.76)	.100 (2.54)	.119 (3.02)	.095 (2.41)	.129 (3.28)	.110 (2.79)	.678 (17.22)	.474 (12.04)

CASE#	N	P	Q	WT. GRAMS
LW1611	.109 (2.77)	.090 (2.29)	.085 (2.16)	0.8

Dimensions are in inches (mm). Tolerances: 2Pl. $\pm .03$; 3Pl. $\pm .015$

Notes:

- Case material: Nickel-Silver alloy.
- Base: Printed wiring laminate.
- Termination finish:
For RoHS Case Styles: 2-5 μ inch (.05-.13 microns) Gold over 120-240 μ inch (3.05-6.10 microns) Nickel plate.
All models, (+) suffix.



P.O. Box 350166, Brooklyn, New York 11235-0003 (718) 934-4500 Fax (718) 332-4661 For detailed performance specs & shopping online see Mini-Circuits web site



The Design Engineers Search Engine Provides ACTUAL Data Instantly From MINI-CIRCUITS At: www.minicircuits.com

RF/IF MICROWAVE COMPONENTS

Tape & Reel Packaging TR-F37

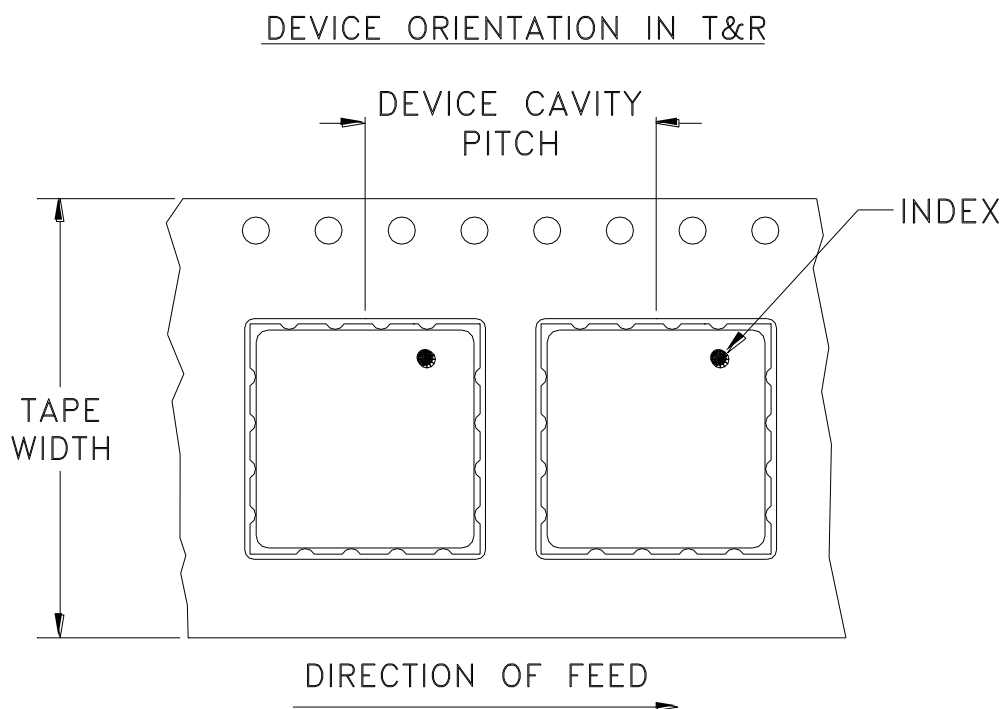

Tape Width, mm	Device Cavity Pitch, mm	Reel Size, inches	Devices per Reel	
24	16	7	Small quantity standards (see note)	10
				20
				50
				100
		13	Standard	200
			500	

Note: Please consult individual model data sheet to determine device per reel availability.

Mini-Circuits carrier tape materials provide protection from ESD (Electro-Static Discharge) during handling and transportation. Tapes are static dissipative and comply with industry standards EIA-481/EIA-541.

Go to: www.minicircuits.com/pages/pdfs/tape.pdf



INTERNET <http://www.minicircuits.com>

P.O. Box 350166, Brooklyn, New York 11235-0003 (718) 934-4500 Fax (718) 332-4661

Distribution Centers NORTH AMERICA 800-654-7949 • 417-335-5935 • Fax 417-335-5945 • EUROPE 44-1252-832600 • Fax 44-1252-837010

Mini-Circuits ISO 9001 & ISO 14001 Certified

THIRD ANGLE PROJECTION

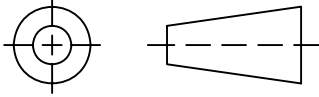

REVISIONS

REV	ECN No.	DESCRIPTION	DATE	DR	AUTH
OR	M129915	NEW RELEASE	APR 11	MD	KG

SUGGESTED MOUNTING CONFIGURATION FOR
LW1611 CASE STYLE "16FL03" PIN CODE

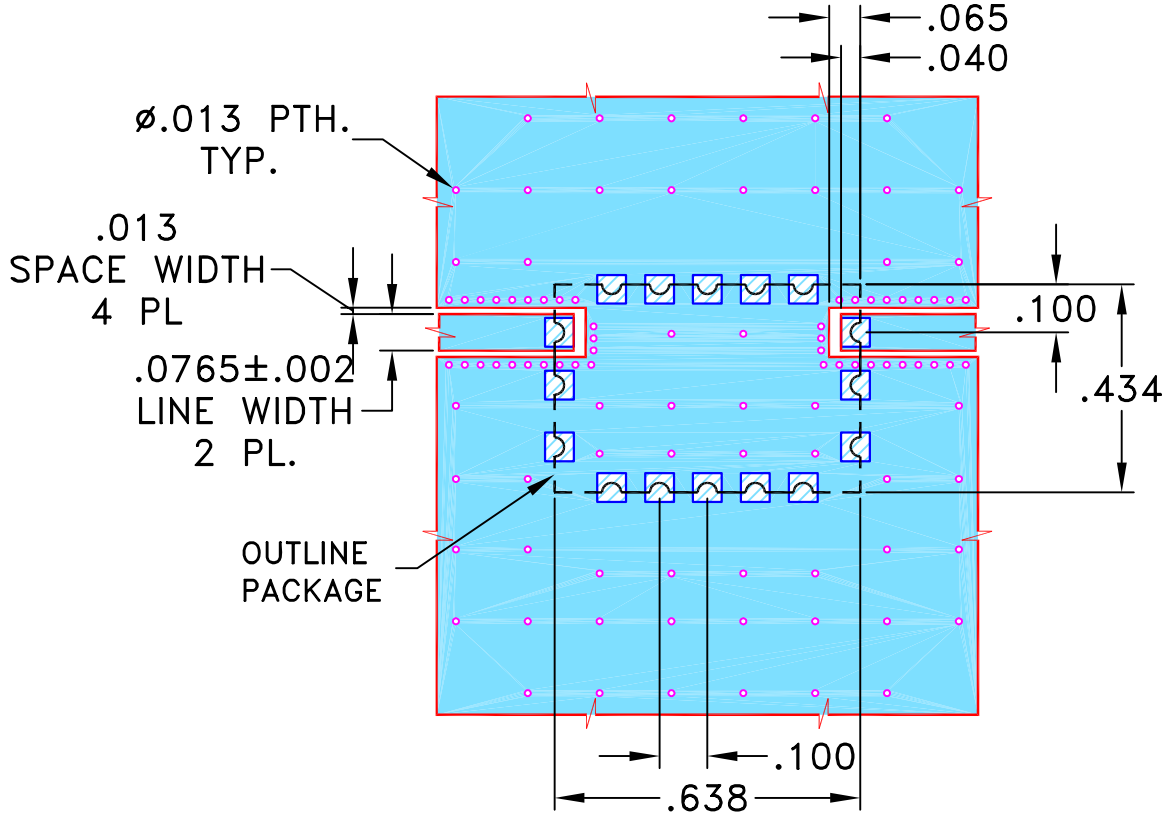

NOTES:

- TRACE WIDTH IS SHOWN FOR ROGERS R04350B WITH DIELECTRIC THICKNESS .060" ± .004". COPPER: 1/2 OZ. EACH SIDE.
FOR OTHER MATERIALS TRACE WIDTH MAY NEED TO BE MODIFIED.
- BOTTOM SIDE OF THE PCB IS CONTINUOUS GROUND PLANE.



DENOTES PCB COPPER LAYOUT WITH SMOBC
(SOLDER MASK OVER BARE COPPER)



DENOTES COPPER LAND PATTERN FREE OF SOLDERMASK

UNLESS OTHERWISE SPECIFIED	INITIALS	DATE
DIMENSIONS ARE IN INCHES TOLERANCES ON: 2 PL DECIMALS ± 3 PL DECIMALS ± .005" ANGLES ± FRACTIONS ±	DRAWN	MD 16 APR 11
	CHECKED	MD 16 APR 11
	APPROVED	KR 16 APR 11



Mini-Circuits® 13 Neptune Avenue
Brooklyn NY 11235

PL, 16FL03, LW1611, CSCR

Mini-Circuits®
THIS DOCUMENT AND ITS CONTENTS ARE THE PROPERTY OF MINI-CIRCUITS. EXCEPT FOR USE EXPRESSLY GRANTED, IN WRITING, TO ITS VENDORS, VENDEE AND THE UNITED STATES GOVERNMENT, MINI-CIRCUITS RESERVES ALL PROPRIETARY DESIGN, USE, MANUFACTURING AND REPRODUCTION RIGHTS THERETO. THESE CONTENTS SHALL NOT BE USED, DUPLICATED OR DISCLOSED TO ANY OUTSIDE PARTY, IN WHOLE OR IN PART, WITHOUT WRITTEN PERMISSION OF MINI-CIRCUITS.
ASHEETA1.DWG REV:A DATE:01/12/95

SIZE A	CODE IDENT 15542	DRAWING NO: 98-PL-338	REV: OR
FILE: 98PL338	SCALE: 2.5:1	SHEET: 1 OF 1	

Evaluation Board and Circuit

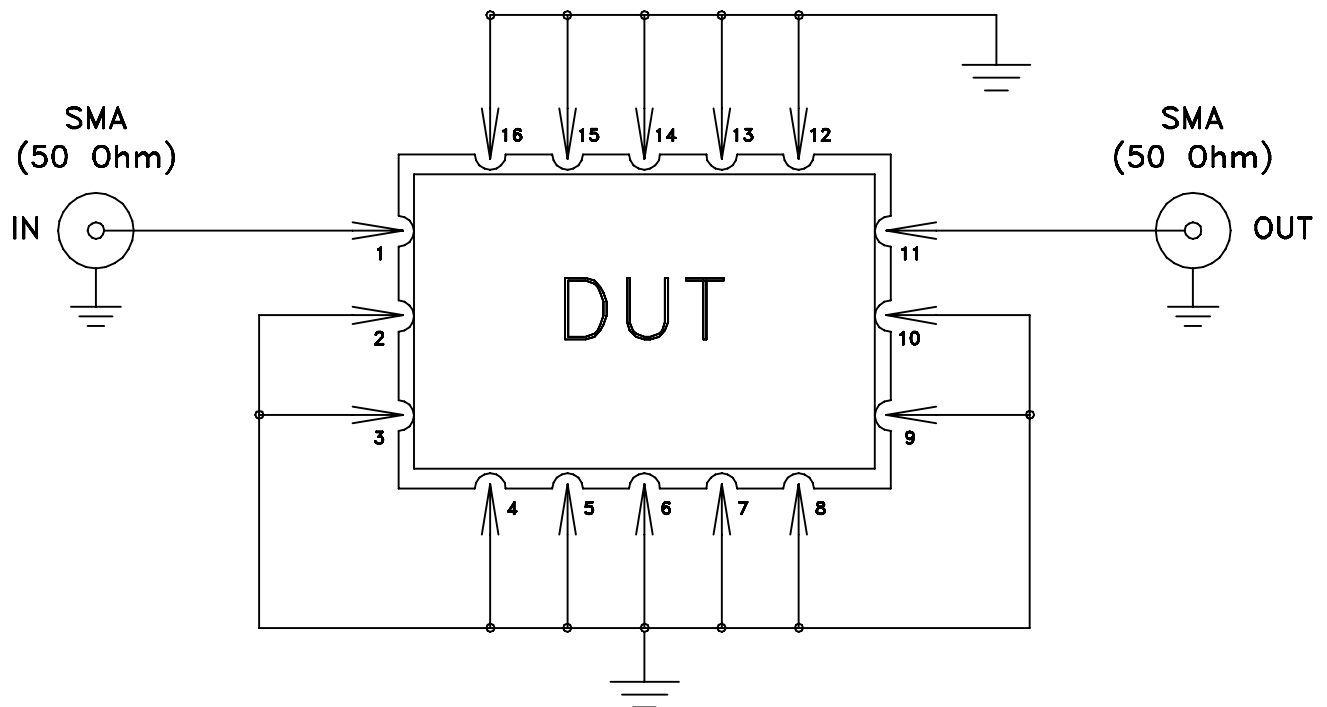
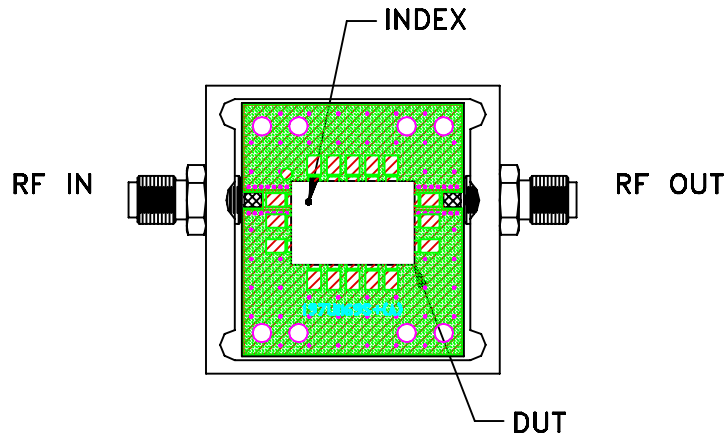

Schematic Diagram

Notes:

1. 50 Ohm SMA Female connectors.
2. PCB Material: ROGERS (R04350B) or equivalent, Dielectric Constant=3.5, Thickness=.060 inch.

 **Mini-Circuits®**

All Mini-Circuits products are manufactured under exacting quality assurance and control standards, and are capable of meeting published specifications after being subjected to any or all of the following physical and environmental test.

Specification	Test/Inspection Condition	Reference/Spec
Operating Temperature	-40° to 85°C Ambient Environment	Individual Model Data Sheet
Storage Temperature	-55° to 100° C Ambient Environment	Individual Model Data Sheet
Humidity	90 to 95% RH, 96 hours, 40°C	MIL-STD-202, Method 103B, Condition B, Except 50°C
Thermal Shock	-55° to 100°C, 100 cycles	MIL-STD-202, Method 107, Condition A-3, except +100°C
Solder Reflow Heat	Sn-Pb Eutectic Process: 225°C peak Pb-Free Process, 245°C peak	J-STD-020, Table 4-1, 4-2 and 5-2, Figure 5-1
Solderability	10X Magnification	J-STD-002, Para 4.2.5, Test S, 95% Coverage
Vibration (High Frequency)	20g peak, 10-2000 Hz, 4 times in each of three axes (total 12)	MIL-STD-202, Method 204, Condition D
Mechanical Shock	50g, 11 ms, 1/2-sine, 18 shocks: 3 each direction, each of 3 axes	MIL-STD-202, Method 213, Condition A