

# Surface Mount Bandpass Filter

## CBP-1280C+

50Ω 1170 to 1390 MHz

### The Big Deal

- Excellent Rejection
- Low passband Insertion Loss
- Miniature shielded package



Generic photo used for illustration purposes only  
CASE STYLE: MP1766

### Product Overview

CBP-1280C+ is a ceramic-coaxial-resonator based bandpass filter in a shielded package fabricated using SMT technology. This filter offers outstanding close in rejection, low insertion loss and high power handling for use in aviation, mobile radio, broadband and fixed wireless.

### Key Features

Feature	Advantages
High Selectivity	The CBP-1280C+ filter incorporates High-Q ceramic resonators that enables sharp rejection near passband.
Low Passband VSWR	This filter maintains typical VSWR over a wide passband frequency range making this filter easier to integrate into receiver and transmitter RF chains with less concerns for in band frequency ripple.
Rugged construction	The CBP-1280C+ has been qualified over wide range of thermal, mechanical and environmental conditions including withstanding the stress of extensive solder reflow cycles.

#### Notes

- A. Performance and quality attributes and conditions not expressly stated in this specification document are intended to be excluded and do not form a part of this specification document.  
B. Electrical specifications and performance data contained in this specification document are based on Mini-Circuit's applicable established test performance criteria and measurement instructions.  
C. The parts covered by this specification document are subject to Mini-Circuits standard limited warranty and terms and conditions (collectively, "Standard Terms"); Purchasers of this part are entitled to the rights and benefits contained therein. For a full statement of the Standard Terms and the exclusive rights and remedies thereunder, please visit Mini-Circuits' website at [www.minicircuits.com/MCLStore/terms.jsp](http://www.minicircuits.com/MCLStore/terms.jsp)



# Surface Mount Bandpass Filter

## CBP-1280C+

50Ω 1170 to 1390 MHz

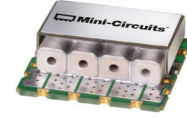

Generic photo used for illustration purposes only  
CASE STYLE: MP1766

### Features

- Low Insertion loss
- High selectivity
- Miniature shielded package

### Applications

- Aviation
- Mobile radio
- Broadband
- Fixed wireless transmitters and receivers

### Electrical Specifications at 25°C

Parameter	F#	Frequency (MHz)	Min.	Typ.	Max.	Unit	
Pass Band	Center Frequency	—	—	1280	—	MHz	
	Insertion Loss	F1-F2	1170-1390	—	0.7	2	dB
	VSWR	F1-F2	1170-1390	—	1.1	—	:1
Stop Band, Lower	Insertion Loss	DC-F3	DC-950	20	29	—	dB
	VSWR	DC-F3	DC-950	—	20	—	:1
Stop Band, Upper	Insertion Loss	F4-F5	1850-2450	20	27	—	dB
	VSWR	F4-F5	1850-2450	—	20	—	:1

### Maximum Ratings

Operating Temperature	-40°C to 85°C
Storage Temperature	-55°C to 100°C
RF Power Input	5W

Permanent damage may occur if any of these limits are exceeded.

### Functional Schematic

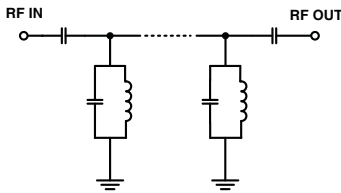

### Typical Frequency Response

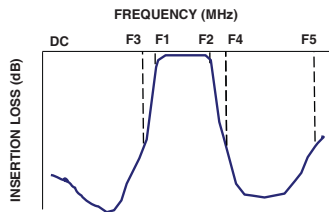

### Typical Performance Data at 25°C

Frequency (MHz)	Insertion Loss (dB)	VSWR (:1)	Frequency (MHz)	Group Delay (nsec)
1	62.59	289.53	1170	2.98
100	102.63	347.44	1176	2.90
500	75.45	144.77	1182	2.83
810	57.03	69.49	1190	2.74
950	30.88	52.65	1200	2.64
1025	15.45	29.96	1204	2.60
1054	8.91	13.92	1214	2.53
1078	4.13	5.23	1222	2.47
1094	2.06	2.75	1234	2.39
1110	1.06	1.68	1248	2.30
1170	0.53	1.08	1262	2.25
1280	0.42	1.01	1280	2.19
1390	0.42	1.06	1292	2.14
1474	1.01	2.00	1314	2.09
1510	2.43	3.78	1332	2.05
1550	5.18	8.35	1342	2.04
1650	13.46	36.20	1354	2.03
1850	28.20	75.53	1370	2.03
2075	62.36	96.51	1380	2.03
2450	45.39	102.19	1390	2.05

### +RoHS Compliant

The +Suffix identifies RoHS Compliance. See our web site for RoHS Compliance methodologies and qualifications

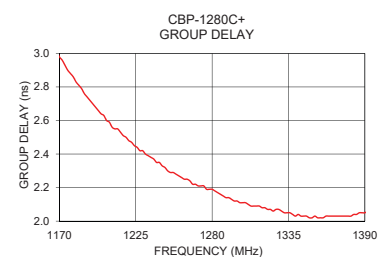
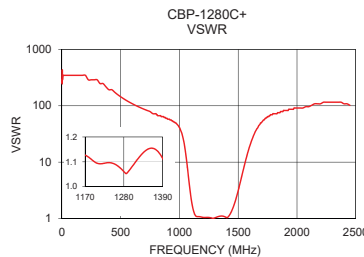
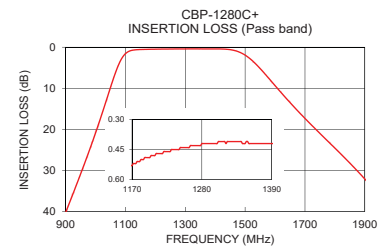
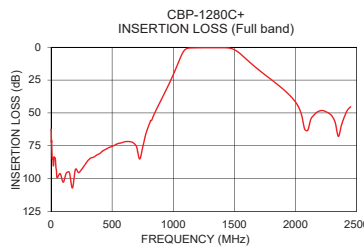

### Notes

- Performance and quality attributes and conditions not expressly stated in this specification document are intended to be excluded and do not form a part of this specification document.
- Electrical specifications and performance data contained in this specification document are based on Mini-Circuits' applicable established test performance criteria and measurement instructions.
- The parts covered by this specification document are subject to Mini-Circuits standard limited warranty and terms and conditions (collectively, "Standard Terms"); Purchasers of this part are entitled to the rights and benefits contained therein. For a full statement of the Standard Terms and the exclusive rights and remedies thereunder, please visit Mini-Circuits' website at [www.minicircuits.com/MCLStore/terms.jsp](http://www.minicircuits.com/MCLStore/terms.jsp)



[www.minicircuits.com](http://www.minicircuits.com) P.O. Box 350166, Brooklyn, NY 11235-0003 (718) 934-4500 sales@minicircuits.com

REV.B  
M174392  
CBP-1280C+  
EDU1838  
URJ  
201024  
Page 2 of 3

## Pad Connections

INPUT	1
OUTPUT	10
GROUND	2,3,4,5,6,7,8,9,11,12,13

**Demo Board MCL P/N: TB-684+**  
**Suggested PCB Layout (PL-373)**

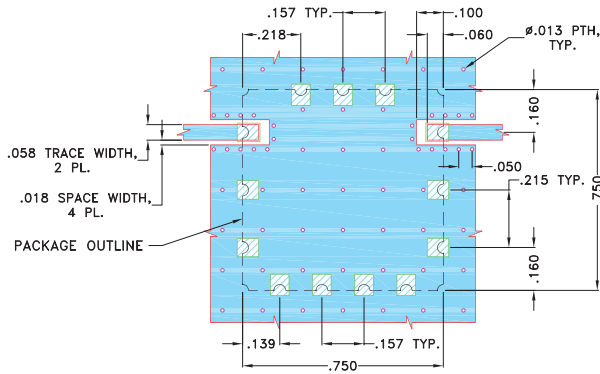

### NOTES:

- TRACE WIDTH IS SHOWN FOR OAK (OAK-602) WITH DIELECTRIC THICKNESS .022"±.0015". COPPER: 1/2 OZ. EACH SIDE. FOR OTHER MATERIALS TRACE WIDTH MAY NEED TO BE MODIFIED.
- BOTTOM SIDE OF THE PCB IS CONTINUOUS GROUND PLANE.

- DENOTES PCB COPPER LAYOUT WITH SMOBC (SOLDER MASK OVER BARE COPPER)
- DENOTES COPPER LAND PATTERN FREE OF SOLDERMASK

## Outline Drawing

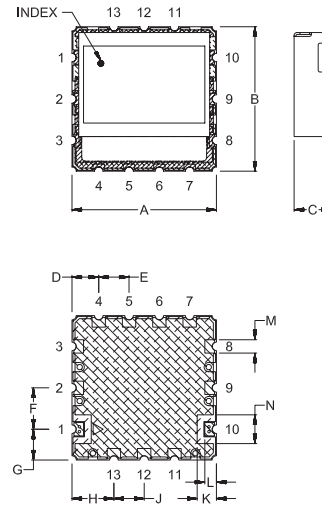

## PCB Land Pattern

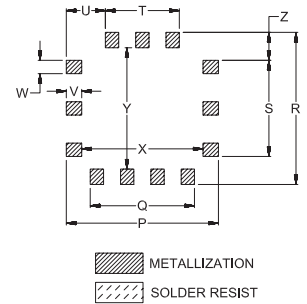

## Outline Dimensions (inch)

A	B	C	D	E	F	G	H	J	K	L	M	N
.750	.750	.210	.139	.157	.215	.160	.218	.157	.100	.060	.069	.149
19.05	19.05	5.33	3.53	3.99	5.46	4.06	5.54	3.99	2.54	1.52	1.75	3.78
P	Q	R	S	T	U	V	W	X	Y	Z	wt.	
.790	.541	.790	.499	.384	.203	.080	.069	.630	.630	.145	grams	
20.07	13.74	20.07	12.67	9.75	5.16	2.03	1.75	16.00	16.00	3.68	4.6	

Note: Please refer to case style drawing for details

### Notes

- Performance and quality attributes and conditions not expressly stated in this specification document are intended to be excluded and do not form a part of this specification document.
- Electrical specifications and performance data contained in this specification document are based on Mini-Circuit's applicable established test performance criteria and measurement instructions.
- The parts covered by this specification document are subject to Mini-Circuits standard limited warranty and terms and conditions (collectively, "Standard Terms"); Purchasers of this part are entitled to the rights and benefits contained therein. For a full statement of the Standard Terms and the exclusive rights and remedies thereunder, please visit Mini-Circuits' website at [www.minicircuits.com/MCLStore/terms.jsp](http://www.minicircuits.com/MCLStore/terms.jsp)

*Typical Performance Data*

FREQ.  (MHz)	INSERTION LOSS			INPUT RETURN LOSS			OUTPUT RETURN LOSS		
	(dB)			(dB)			(dB)		
	@-40°C	@+25°C	@+85°C	@-40°C	@+25°C	@+85°C	@-40°C	@+25°C	@+85°C
1	58.83	62.59	55.90	0.08	0.06	0.08	0.07	0.05	0.08
5	73.58	70.86	73.07	0.05	0.06	0.06	0.06	0.06	0.06
15	104.72	84.15	86.73	0.05	0.05	0.05	0.05	0.05	0.05
20	88.66	90.29	86.53	0.05	0.05	0.05	0.05	0.05	0.05
30	88.15	84.34	81.34	0.05	0.05	0.05	0.04	0.05	0.05
45	93.02	94.28	92.65	0.05	0.05	0.05	0.04	0.05	0.05
100	98.08	102.63	99.31	0.04	0.05	0.05	0.03	0.04	0.04
150	103.94	95.23	100.25	0.04	0.05	0.05	0.03	0.04	0.04
275	88.07	89.79	88.81	0.04	0.06	0.07	0.03	0.05	0.06
350	81.85	83.59	82.57	0.05	0.07	0.08	0.04	0.06	0.07
450	77.08	77.55	76.46	0.07	0.10	0.11	0.06	0.09	0.10
575	72.78	72.79	72.84	0.11	0.15	0.16	0.09	0.13	0.14
725	81.28	85.04	83.48	0.17	0.21	0.23	0.15	0.19	0.21
775	66.44	66.17	66.04	0.19	0.24	0.25	0.17	0.22	0.23
805	58.36	58.16	58.22	0.20	0.25	0.26	0.19	0.23	0.25
830	54.24	54.07	53.90	0.21	0.26	0.27	0.19	0.24	0.26
850	49.94	49.76	49.67	0.22	0.27	0.28	0.20	0.25	0.27
900	40.45	40.27	40.11	0.24	0.30	0.31	0.23	0.28	0.30
920	36.72	36.55	36.37	0.25	0.31	0.32	0.24	0.29	0.31
945	32.02	31.83	31.66	0.27	0.33	0.35	0.26	0.31	0.34
950	31.06	30.88	30.70	0.27	0.33	0.35	0.26	0.32	0.34
965	28.16	27.97	27.78	0.28	0.35	0.37	0.27	0.33	0.36
985	24.19	23.99	23.78	0.31	0.38	0.41	0.30	0.37	0.40
1010	18.96	18.74	18.52	0.38	0.47	0.51	0.38	0.46	0.50
1030	14.56	14.33	14.10	0.52	0.64	0.69	0.52	0.64	0.70
1050	10.03	9.80	9.58	0.91	1.09	1.19	0.93	1.10	1.20
1066	6.54	6.35	6.16	1.72	2.00	2.18	1.74	2.03	2.21
1082	3.59	3.50	3.40	3.54	4.00	4.31	3.59	4.06	4.38
1100	1.54	1.58	1.57	7.62	8.36	8.83	7.73	8.52	9.02
1116	0.77	0.88	0.92	13.36	14.38	14.96	13.66	14.83	15.51
1124	0.61	0.73	0.78	16.99	18.15	18.75	17.56	19.04	19.83
1132	0.52	0.65	0.71	21.06	22.29	22.82	22.36	24.35	25.32
1144	0.45	0.59	0.64	26.94	27.42	27.49	32.69	35.92	36.44
1160	0.42	0.55	0.60	28.69	28.31	28.29	35.39	33.20	32.75
1170	0.40	0.53	0.58	28.72	28.59	28.69	33.30	32.08	31.91
1186	0.38	0.50	0.55	30.02	30.41	30.62	34.42	33.76	33.56
1206	0.36	0.48	0.53	32.55	33.35	33.47	36.32	35.68	35.22
1220	0.34	0.46	0.51	33.08	33.51	33.72	34.56	33.99	33.94
1234	0.34	0.45	0.50	32.81	32.84	33.27	32.97	32.56	32.89
1270	0.31	0.43	0.48	38.66	38.14	40.16	36.34	36.34	38.14
1280	0.31	0.42	0.47	46.87	45.49	51.54	40.36	41.10	44.96
1316	0.30	0.41	0.46	31.12	31.44	30.73	31.94	32.36	31.62
1390	0.29	0.42	0.47	28.47	30.17	31.08	29.27	31.40	32.68
1426	0.31	0.45	0.52	24.98	23.16	22.22	25.16	23.31	22.31
1438	0.35	0.51	0.58	19.53	18.39	17.74	19.57	18.43	17.76
1450	0.43	0.60	0.69	15.58	14.80	14.31	15.60	14.82	14.32
1462	0.57	0.77	0.86	12.47	11.91	11.53	12.49	11.93	11.55
1472	0.75	0.96	1.07	10.33	9.91	9.61	10.34	9.92	9.61
1482	1.00	1.24	1.36	8.51	8.20	7.97	8.51	8.20	7.96
1502	1.75	2.02	2.18	5.68	5.54	5.39	5.67	5.53	5.39
1520	2.74	3.03	3.20	3.88	3.84	3.76	3.87	3.83	3.76
1554	5.21	5.50	5.68	1.89	1.94	1.93	1.88	1.93	1.93
1590	8.23	8.50	8.66	0.95	1.02	1.04	0.93	1.01	1.04
1675	15.22	15.43	15.54	0.32	0.39	0.41	0.31	0.38	0.41
1765	21.87	22.06	22.14	0.20	0.26	0.28	0.19	0.25	0.28
1850	28.03	28.20	28.26	0.17	0.23	0.25	0.16	0.22	0.24
1945	35.76	35.96	36.03	0.14	0.20	0.22	0.14	0.20	0.22
2050	51.68	51.79	51.66	0.12	0.19	0.21	0.13	0.19	0.21
2350	66.08	67.80	69.77	0.07	0.15	0.19	0.08	0.16	0.19
2450	45.11	45.39	45.50	0.07	0.17	0.21	0.09	0.18	0.22

# Band Pass Filter

# CBP-1280C+

## Typical Performance Data

FREQ.  (MHz)	GROUP DELAY		
	(nsec)		
	@-40°C	@+25°C	@+85°C
1170	3.01	2.98	2.96
1172	2.99	2.96	2.93
1174	2.96	2.93	2.91
1178	2.91	2.88	2.86
1182	2.86	2.83	2.82
1186	2.81	2.79	2.77
1188	2.78	2.76	2.74
1190	2.76	2.74	2.73
1194	2.73	2.70	2.69
1196	2.69	2.68	2.66
1198	2.68	2.66	2.64
1200	2.66	2.64	2.62
1202	2.64	2.63	2.61
1204	2.62	2.60	2.59
1206	2.60	2.59	2.57
1210	2.58	2.55	2.54
1214	2.54	2.53	2.51
1218	2.51	2.50	2.48
1220	2.50	2.48	2.47
1224	2.47	2.45	2.44
1228	2.45	2.42	2.42
1234	2.41	2.39	2.39
1238	2.38	2.37	2.36
1240	2.36	2.35	2.34
1244	2.34	2.33	2.32
1246	2.33	2.32	2.31
1250	2.31	2.29	2.28
1254	2.30	2.28	2.27
1256	2.29	2.27	2.26
1258	2.27	2.26	2.24
1260	2.27	2.25	2.24
1264	2.25	2.24	2.23
1268	2.23	2.22	2.21
1274	2.22	2.21	2.20
1280	2.19	2.19	2.17
1282	2.19	2.18	2.17
1286	2.17	2.16	2.15
1288	2.16	2.15	2.14
1290	2.16	2.14	2.14
1294	2.15	2.13	2.13
1298	2.13	2.12	2.11
1302	2.12	2.11	2.11
1306	2.11	2.10	2.09
1308	2.10	2.09	2.08
1318	2.09	2.08	2.07
1320	2.09	2.07	2.07
1324	2.08	2.06	2.06
1326	2.07	2.07	2.06
1330	2.07	2.06	2.05
1334	2.06	2.05	2.05
1338	2.05	2.04	2.04
1346	2.04	2.03	2.02
1352	2.03	2.02	2.02
1358	2.03	2.02	2.02
1362	2.03	2.03	2.02
1370	2.04	2.03	2.03
1376	2.04	2.03	2.03
1382	2.05	2.04	2.04
1386	2.05	2.05	2.05
1390	2.06	2.05	2.06

## Typical Performance Curves

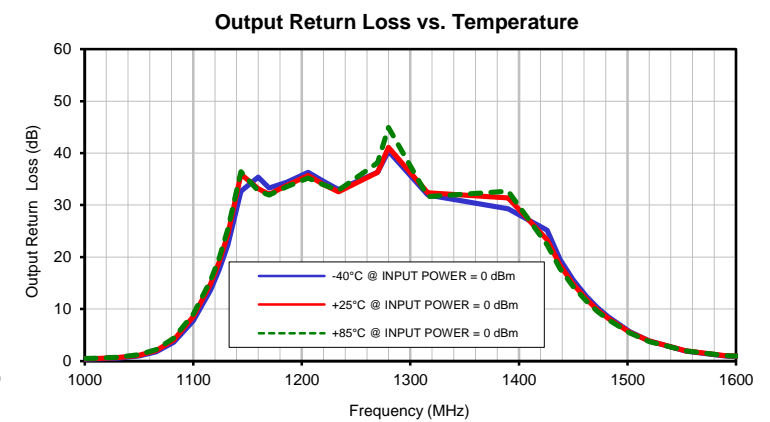
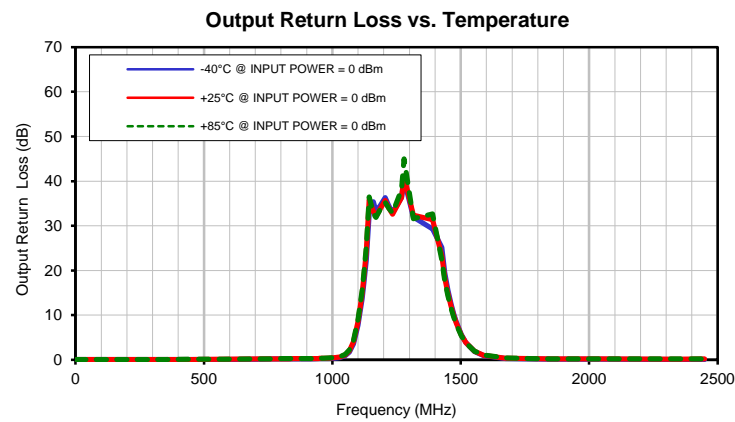
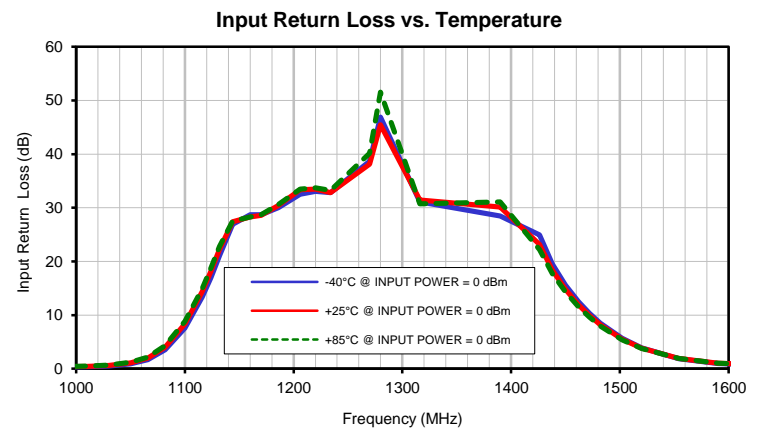
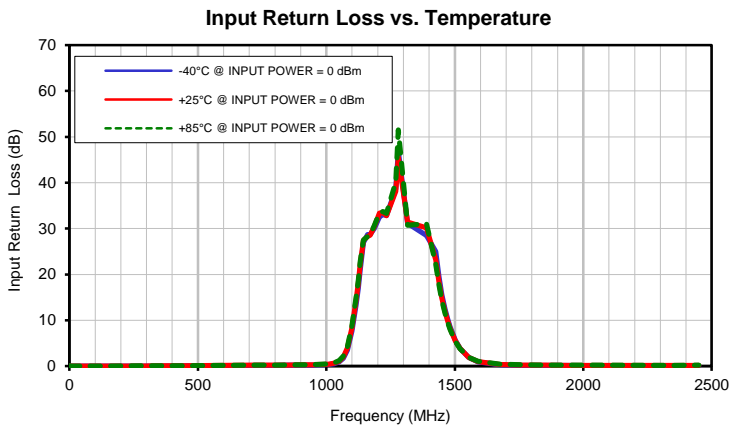
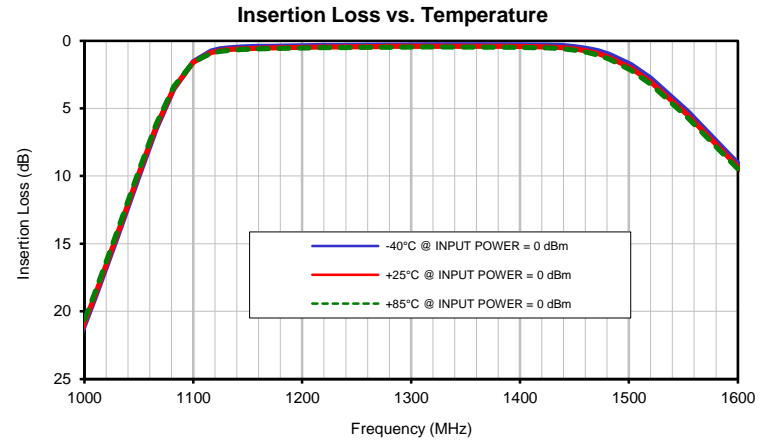
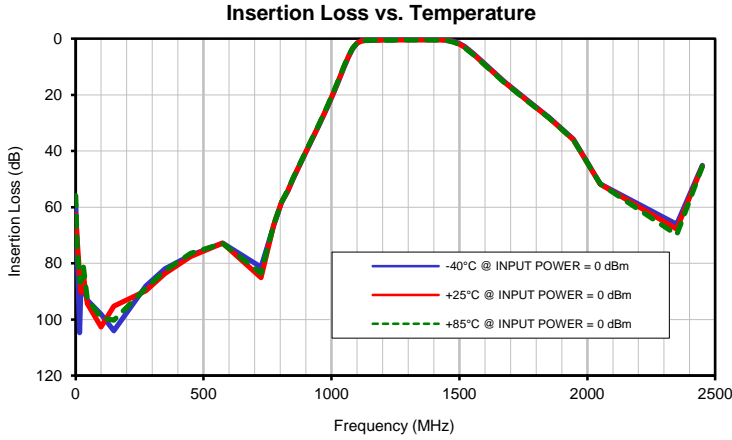

# Band Pass Filter

# CBP-1280C+

## Typical Performance Curves

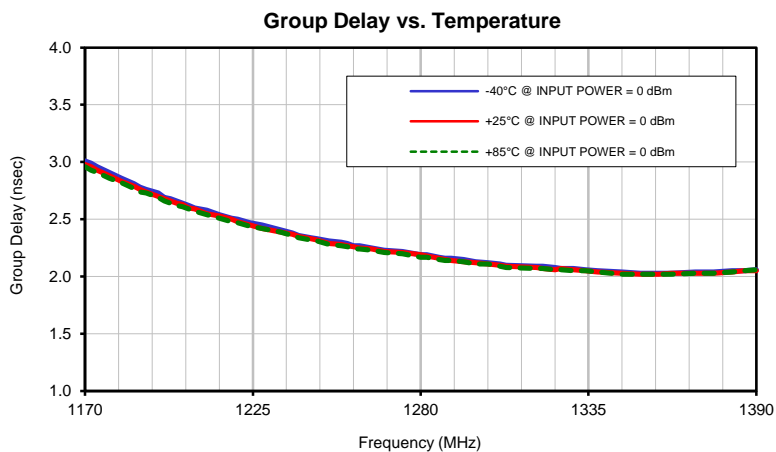

## Outline Dimensions

MP1766

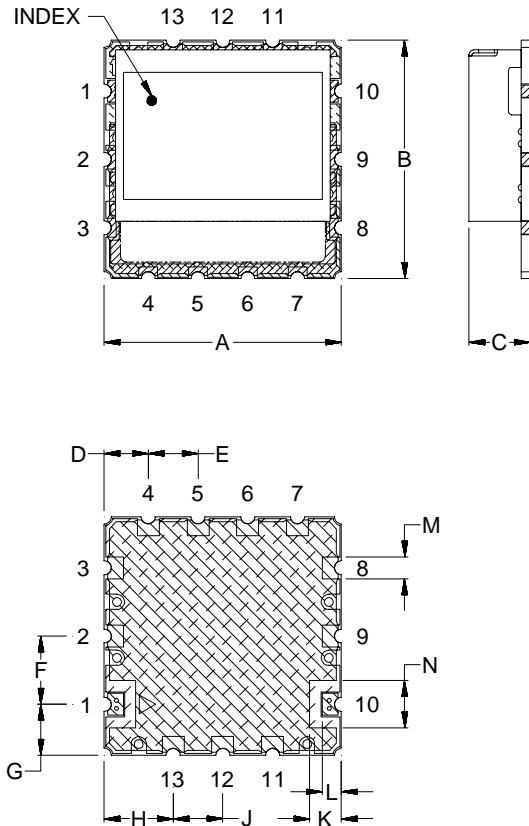

## PCB Land Pattern

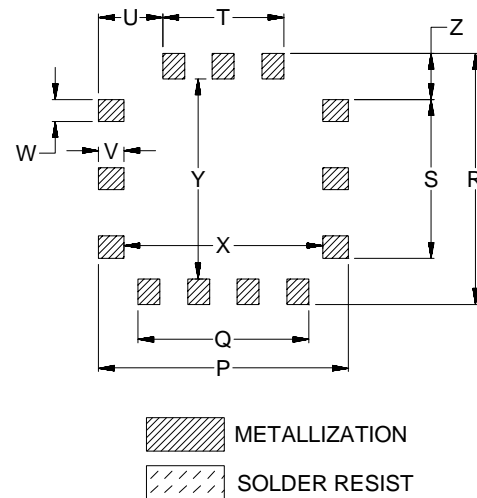

CASE#	A	B	C	D	E	F	G	H	J	K	L	M	N
MP1766	.750 (19.05)	.750 (19.05)	.210 (5.33)	.139 (3.53)	.157 (3.99)	.215 (5.46)	.160 (4.06)	.218 (5.54)	.157 (3.99)	.100 (2.54)	.060 (1.52)	.069 (1.75)	.149 (3.78)

CASE#	P	Q	R	S	T	U	V	W	X	Y	Z	WT.GRAMS
MP1766	.790 (20.07)	.541 (13.74)	.790 (20.07)	.499 (12.67)	.384 (9.75)	.203 (5.16)	.080 (2.03)	.069 (1.75)	.630 (16.00)	.630 (16.00)	.145 (3.68)	4.6

Dimensions are in inches (mm). Tolerances: 2PL.  $\pm .03$ ; 3PL.  $\pm .015$

### Notes:

- Case material: Nickel-Silver alloy.
- Base: Printed wiring laminate.
- Termination finish:  
For RoHS Case Styles: 2-5  $\mu$  inch (.05-.13 microns) Gold over 120-240  $\mu$  inch (3.05-6.10 microns) Nickel plate.  
All models, (+) suffix.

**Mini-Circuits®**  
ISO 9001 ISO 14001 CERTIFIED

ALL NEW  
minicircuits.com

P.O. Box 350166, Brooklyn, New York 11235-0003 (718) 934-4500 Fax (718) 332-4661 For detailed performance specs & shopping online see Mini-Circuits web site



The Design Engineers Search Engine Provides ACTUAL Data Instantly From MINI-CIRCUITS At: [www.minicircuits.com](http://www.minicircuits.com)

RF/IF MICROWAVE COMPONENTS



# Tape & Reel Packaging TR-F111

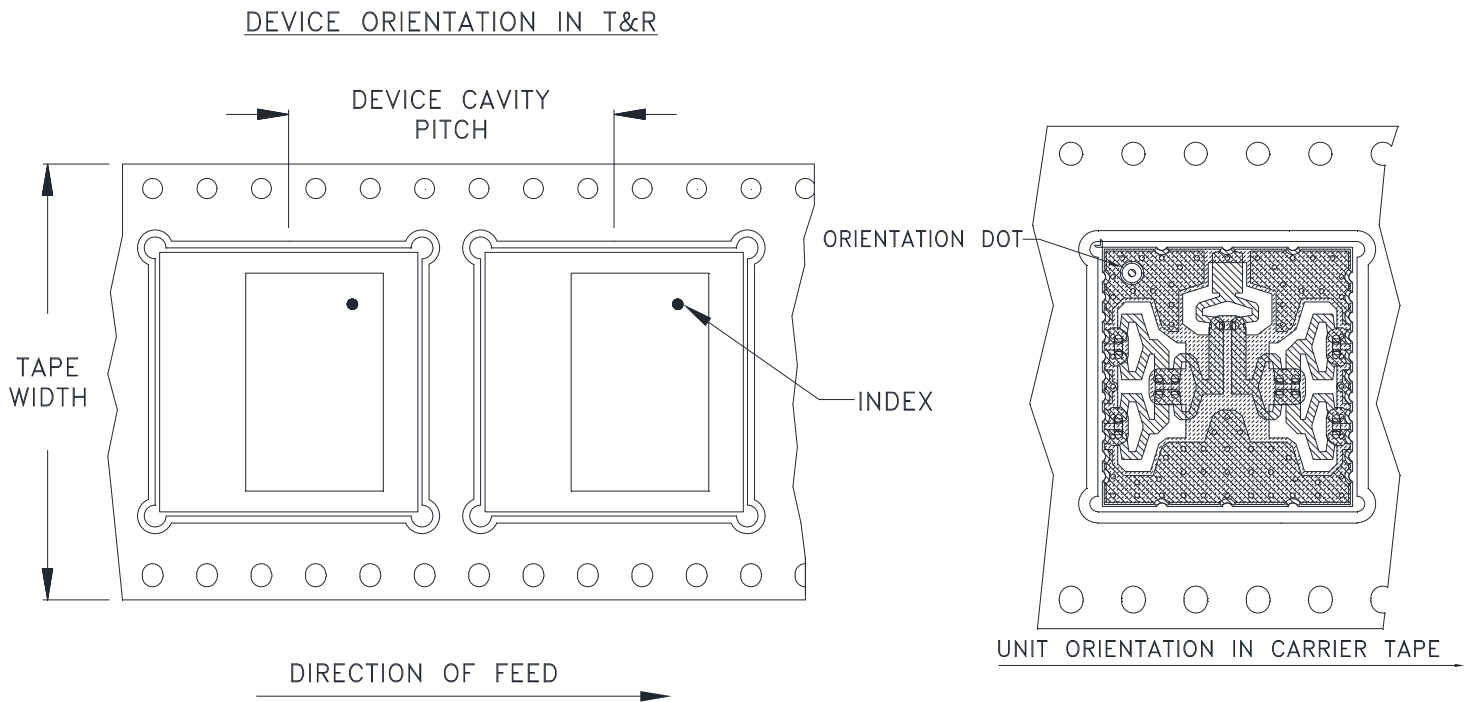

Applicable Case styles:

Applicable Case styles:RS1539

Tape Width, mm	Device Cavity Pitch, mm	Reel Size, inches	Devices per Reel
32	24	13	250

Mini-Circuits carrier tape materials provide protection from ESD (Electro-Static Discharge) during handling and transportation. Tapes are static dissipative and comply with industry standards EIA-481/EIA-541.

Go to: [www.minicircuits.com/pages/pdfs/tape.pdf](http://www.minicircuits.com/pages/pdfs/tape.pdf)



INTERNET <http://www.minicircuits.com>

P.O. Box 350166, Brooklyn, New York 11235-0003 (718) 934-4500 Fax (718) 332-4661

Distribution Centers NORTH AMERICA 800-654-7949 • 417-335-5935 • Fax 417-335-5945 • EUROPE 44-1252-832600 • Fax 44-1252-837010

Mini-Circuits ISO 9001 & ISO 14001 Certified

THIRD ANGLE PROJECTION

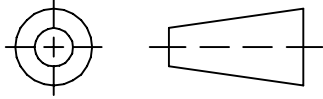

REVISIONS

REV OR	ECN No.	DESCRIPTION	DATE	DR	AUTH
	M137721	NEW RELEASE	JUN 12	DDR	KG

**SUGGESTED MOUNTING CONFIGURATION FOR  
MP1766 CASE STYLE "13FL01" PIN CODE**

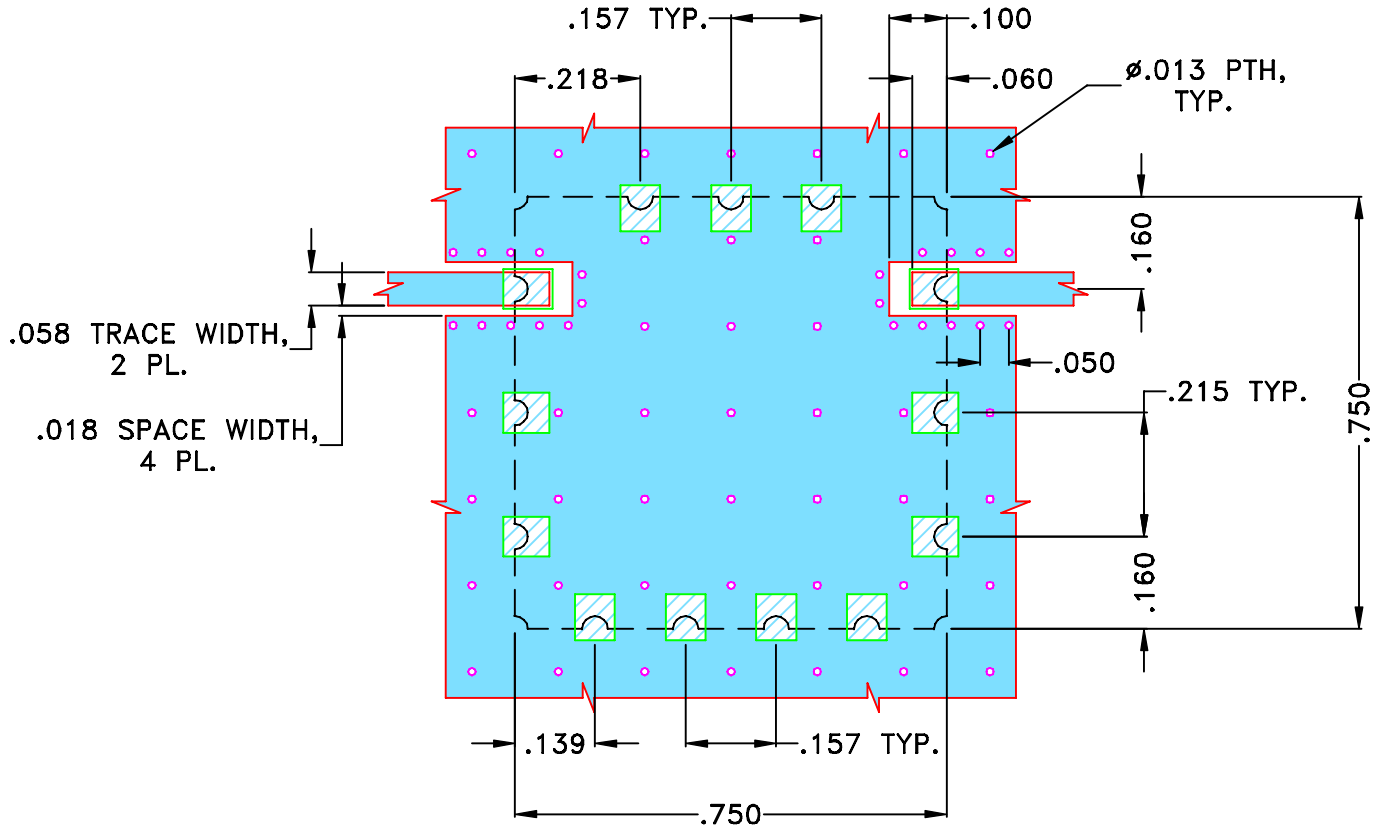

**NOTES:**

1. TRACE WIDTH IS SHOWN FOR OAK (OAK-602) WITH DIELECTRIC THICKNESS .022"±.0015". COPPER: 1/2 OZ. EACH SIDE.  
FOR OTHER MATERIALS TRACE WIDTH MAY NEED TO BE MODIFIED.
2. BOTTOM SIDE OF THE PCB IS CONTINUOUS GROUND PLANE.

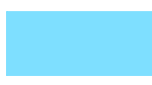
 DENOTES PCB COPPER LAYOUT WITH SMOBC  
(SOLDER MASK OVER BARE COPPER)

 DENOTES COPPER LAND PATTERN FREE OF SOLDERMASK

UNLESS OTHERWISE SPECIFIED	INITIALS	DATE
DIMENSIONS ARE IN INCHES TOLERANCES ON: 2 PL DECIMALS ± 3 PL DECIMALS ± .005" ANGLES ± FRACTIONS ±	DRAWN	DDR 22 JUN 12
	CHECKED	MD 22 JUN 12
	APPROVED	GM 22 JUN 12

 **Mini-Circuits®** 13 Neptune Avenue  
Brooklyn NY 11235

**PL, 13FL01, MP1766, BPF,  
TB-684+, 50 Ohm**

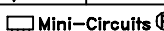
 Mini-Circuits®  
THIS DOCUMENT AND ITS CONTENTS ARE THE PROPERTY OF MINI-CIRCUITS.  
EXCEPT FOR USE EXPRESSLY GRANTED, IN WRITING, TO ITS VENDORS, VENDEE  
AND THE UNITED STATES GOVERNMENT, MINI-CIRCUITS RESERVES ALL PROPRIETARY  
DESIGN, USE, MANUFACTURING AND REPRODUCTION RIGHTS THERE TO.  
THESE CONTENTS SHALL NOT BE USED, DUPLICATED OR DISCLOSED TO ANY OUTSIDE  
PARTY, IN WHOLE OR IN PART, WITHOUT WRITTEN PERMISSION OF MINI-CIRCUITS.

SIZE A	CODE IDENT 15542	DRAWING NO: 98-PL-373	REV: OR
FILE: 98PL373	SCALE: 4:1	SHEET: 1 OF 1	

# Evaluation Board and Circuit

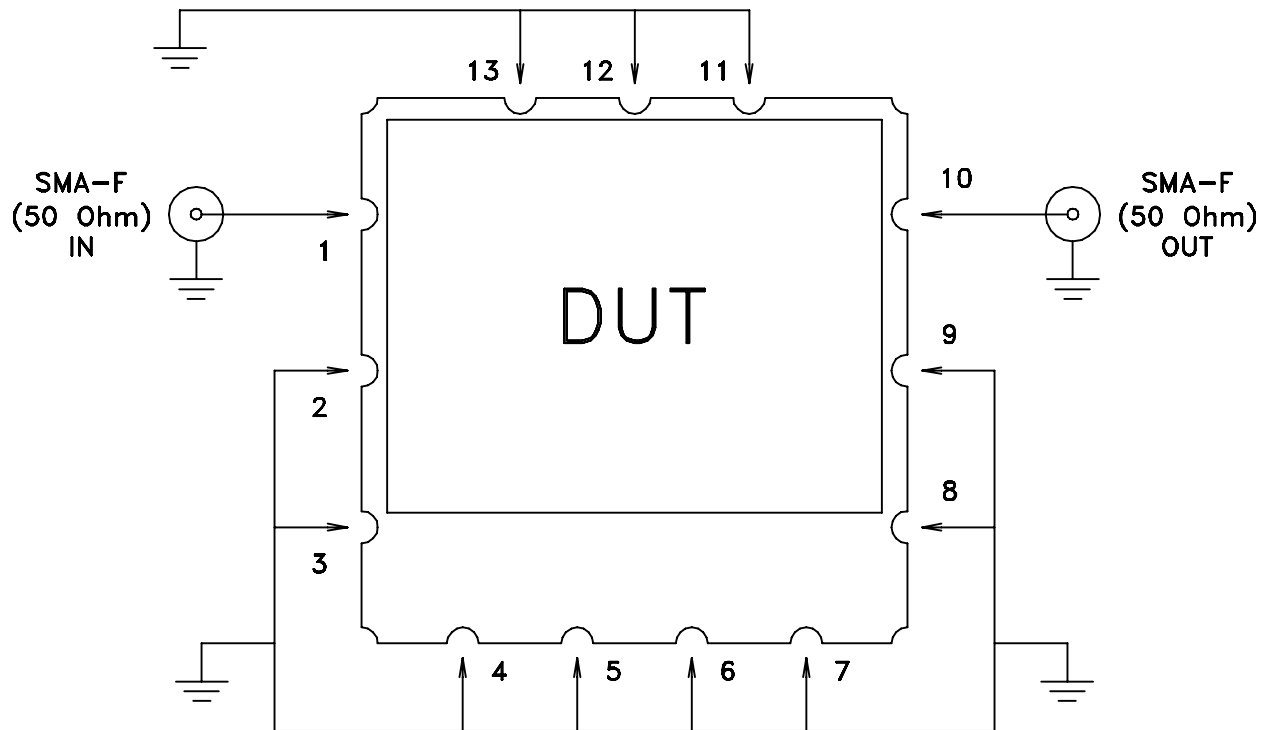
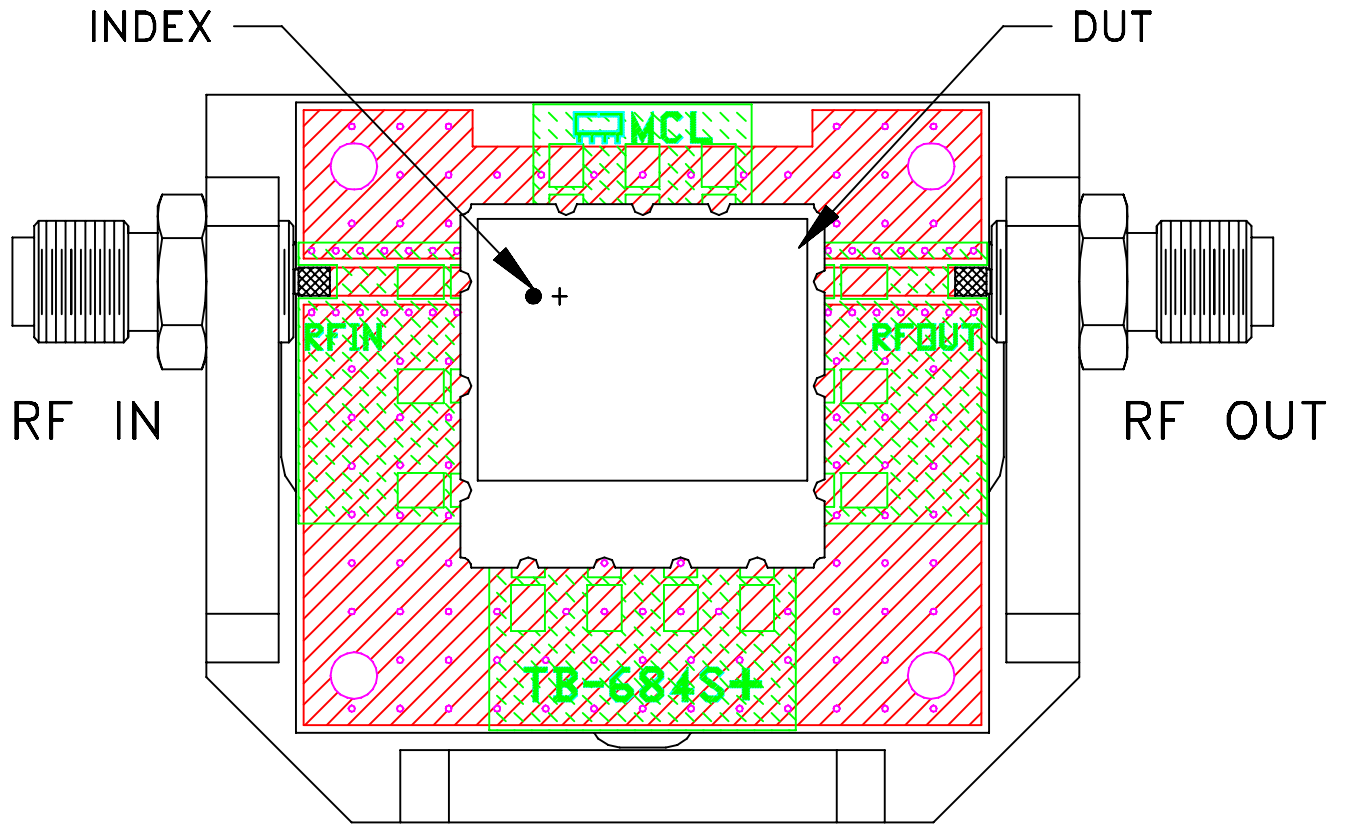

Schematic Diagram

**Notes:**

1. 50 Ohm SMA Female connectors.
2. PCB Material: OAK-602 OR Equivalent  
Dielectric Constant=2.50±.04, Thickness=.022 inch.

 Mini-Circuits®

All Mini-Circuits products are manufactured under exacting quality assurance and control standards, and are capable of meeting published specifications after being subjected to any or all of the following physical and environmental test.

Specification	Test/Inspection Condition	Reference/Spec
Operating Temperature	-40° to 85°C Ambient Environment	Individual Model Data Sheet
Storage Temperature	-55° to 100° C Ambient Environment	Individual Model Data Sheet
Humidity	90 to 95% RH, 96 hours, 40°C	MIL-STD-202, Method 103B, Condition B, Except 50°C
Thermal Shock	-55° to 100°C, 100 cycles	MIL-STD-202, Method 107, Condition A-3, except +100°C
Solder Reflow Heat	Sn-Pb Eutectic Process: 225°C peak Pb-Free Process, 245°C peak	J-STD-020, Table 4-1, 4-2 and 5-2, Figure 5-1
Solderability	10X Magnification	J-STD-002, Para 4.2.5, Test S, 95% Coverage
Vibration (High Frequency)	20g peak, 10-2000 Hz, 4 times in each of three axes (total 12)	MIL-STD-202, Method 204, Condition D
Mechanical Shock	50g, 11 ms, 1/2-sine, 18 shocks: 3 each direction, each of 3 axes	MIL-STD-202, Method 213, Condition A